

Lillian

EXPOSED BATH SET WITH HAND SHOWER

336105/339105

WELS 3 Star rated, 9L/min

Rail:

- Separate hot and cold water inlets
- ¼ turn ceramic disc cross handles
- Made from solid brass
- 1.5 metre stainless steel hose (PVC on matte black model)

LILLIAN Hand Shower (MSH003):

- Single water flow setting
- Made from solid brass
- Female ½" BSP inlet

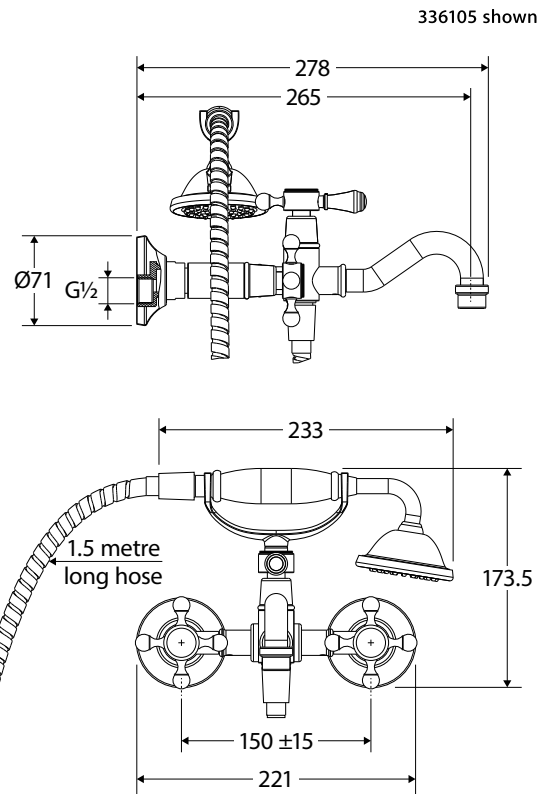

IMPORTANT: Please read all of the instructions before installation. Check the product thoroughly for damage. Installation is acceptance of goods supplied and will void warranty. This product is pre-assembled. Do not disassemble, as this may void the warranty.

Specifications

Please refer to fienza.com.au for the latest product specifications before installing.

Operating Pressure	Min: 150 kPa / 1.5 bar Max: 500 kPa / 5 bar (As per AS/NZS3500) Op mum: 150 kPa / 1.5 bar – 500 kPa / 5 bar Hot and cold water inlet pressure should be equal.
Operating Temperature	Hot: Max 80°C maximum continuous working temperature. Cold: Min. 5°C
Inlet Connections	1/2" BSPP
Suitable Hot Water Units	Storage tank and continuous flow only. Not suitable for gravity feed.
WELS Rating	3 Star rated, 9L/min

General Information

- This product must be installed by a qualified licensed plumber in accordance with AS/NZS 3500 and all applicable local regulations and plumbing codes.
- All pipe work must be thoroughly flushed prior to installation.
- After installation all hoses and connections must be checked for leaks.
- It is the responsibility of the installer to ensure a waterproof seal is achieved between the product and mounting surface.

Installation

IMPORTANT:

- Before commencing installation, turn off the water supply. While not essential, we recommend fitting isolation valves to both the hot and cold-water supply.
- Some showers may not provide an effective shower when used with gravity fed heated water systems or where pressures are less than 150kPa at the outlet. Additionally, showers with flow rates of less than 9L/min may not allow the following to function correctly:
 - Some instantaneous water heaters
 - Some tempering valves
 - Some thermostatic mixing valves
- Some shower heads only operate correctly when hot and cold water supplies are both mains pressure and may not be suitable for some instantaneous hot water services.
- When water pressure is in excess of 500kPa a pressure limiting device is required.

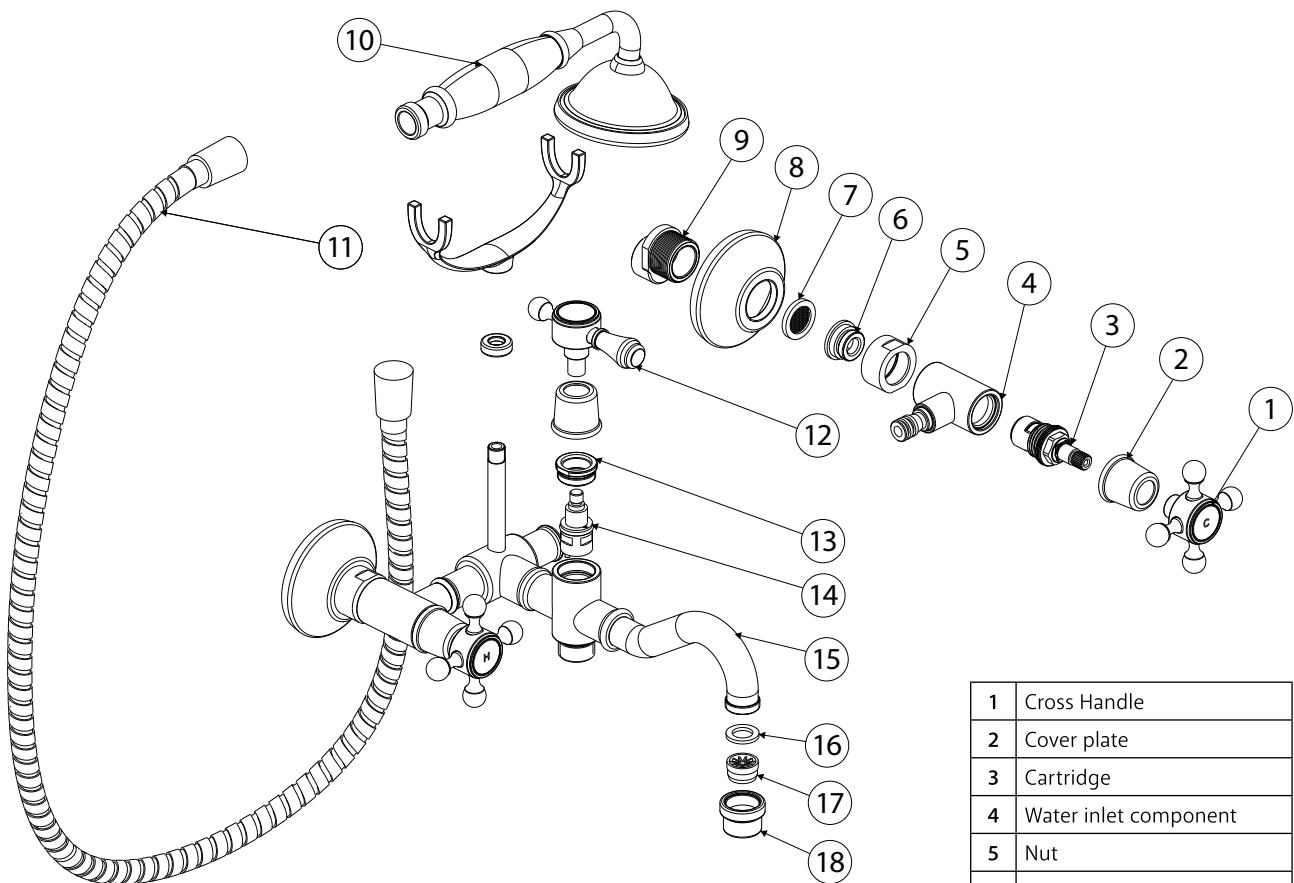

1	Cross Handle
2	Cover plate
3	Cartridge
4	Water inlet component
5	Nut
6	Nut
7	Washer
8	Cover plate
9	Connector
10	Hand shower
11	Hose
12	Lever handle
13	Cover plate
14	Cartridge
15	Spout
16	Washer
17	Aerator
18	Aerator cover plate

1. Screw the 2 brass flanges onto the water outlets using a spanner. Tighten each side by ½ turns until firmly tightened against the wall. Put 2 cover plates over brass flanges, as below.

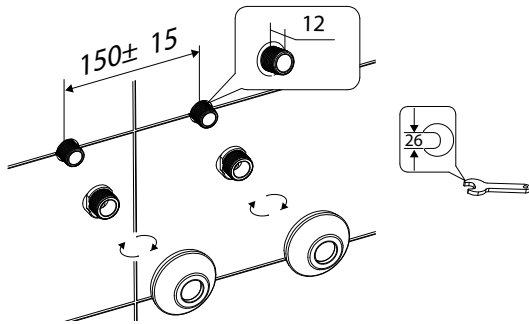

2. Attach the hand shower holder and tighten the grub screw with the Allen key provided.

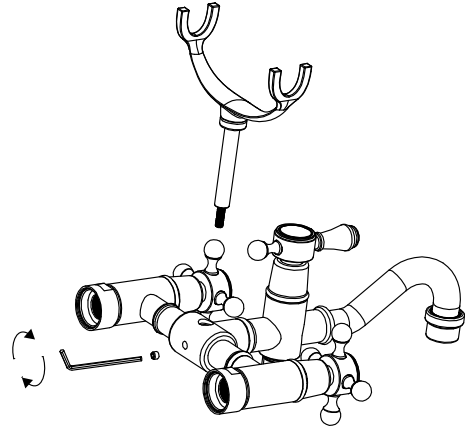

3. Attach the wall mounted bath set to the wall at the fixing points by pushing the wall brackets over the 2 connectors and tighten using a spanner.

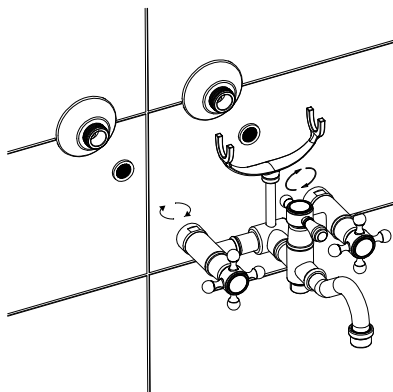

4. Attach the shower hose and hand shower.

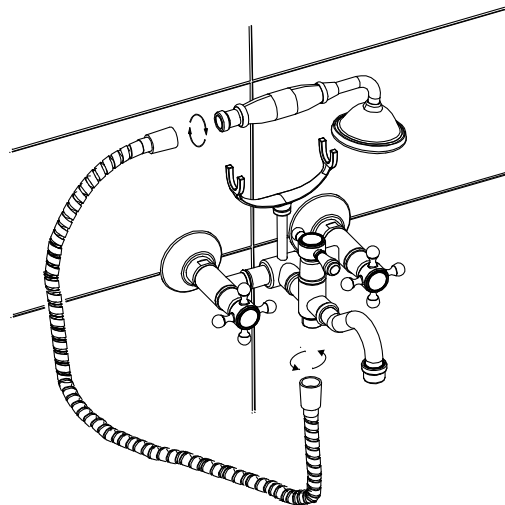

Cleaning & Care

We recommend weekly cleaning with mild soapy water and a microfibre cloth. In highly polluted or coastal locations we recommend cleaning 2-3 times per week. Please note that colour tapware requires more frequent cleaning than chrome tapware.

- Never use harsh detergents, citrus-based cleaners or abrasive cleaners, as these will scratch the surface. Use of unsuitable cleaners may damage the surface and will not be covered by warranty.
- Where your tapware remains dry in use, a non-abrasive soft cloth can be used to remove surface dust.
- Use of wax-based furniture creams should be avoided as these can result in a build-up of deposits which can effect the appearance.
- Do not use undue pressure and wipe in one direction only.

Changing Cross Handles to Lever Handles (339105)

Please follow the installation instructions on this guide to change the handles on your LILLIAN product from the standard cross handles to the lever handles.

IMPORTANT: Before commencing installation, turn off the water supply. While not essential, we recommend fitting isolation valves to both the hot and cold-water supply.

1. Remove the H and C Caps.

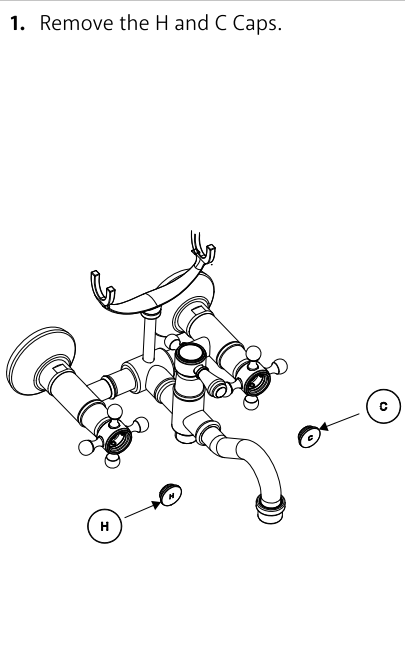

2. Remove the screws by using a screwdriver in anti-clockwise direction, then remove the cross handles.

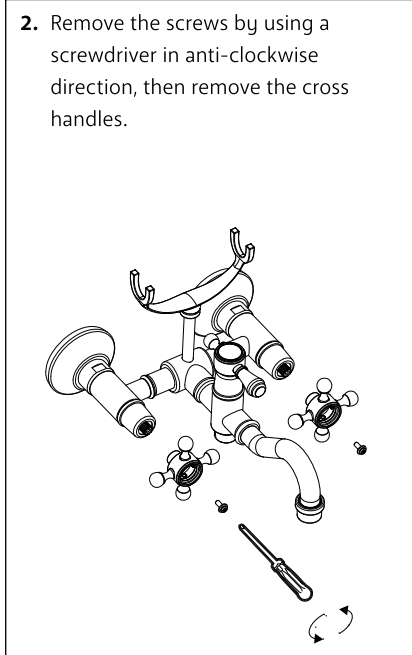

3. Remove the Left cartridge cover plate turning anti-clockwise, then take out the RED cartridge by using a spanner in anti-clockwise direction.

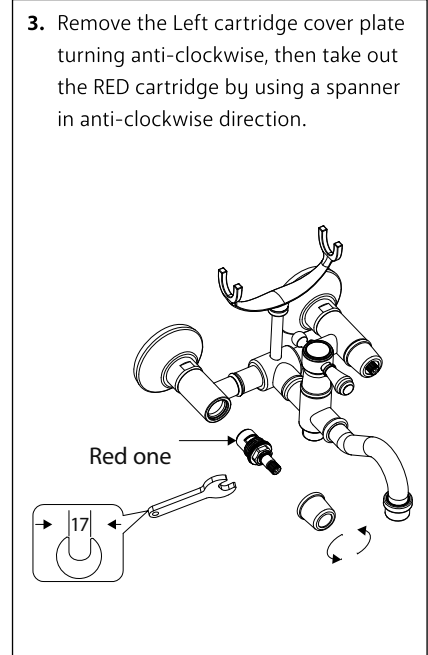

4. Insert BLUE cartridge. Tighten the cartridge by using spanner in clockwise direction, tighten the cartridge cover plate in clockwise direction.

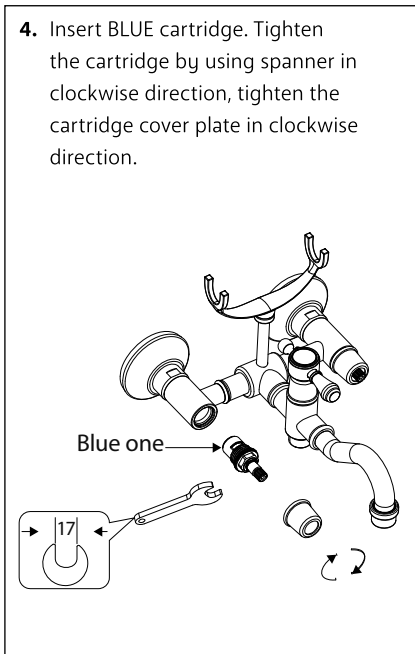

5. Tighten the H cartridge switch anti clockwise. Tighten the C cartridge switch clockwise. Attach the lever handles to the cartridge and tighten the screws by using a screwdriver.

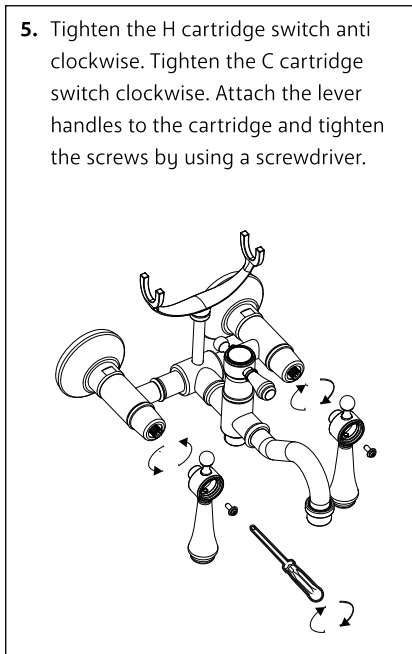

6. Attach the H and C cover plates.

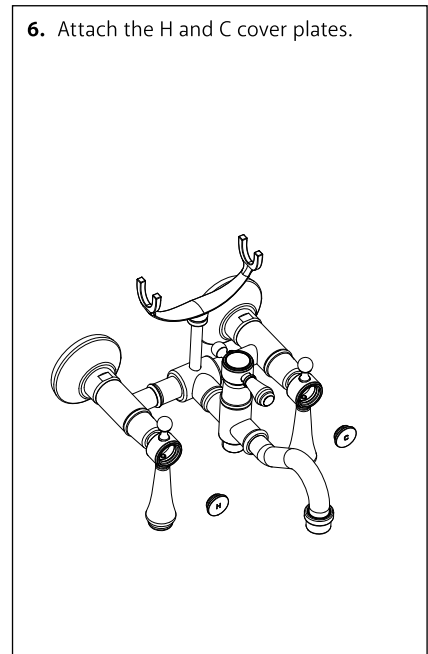

Warranties

Residential Warranty Periods

Applies to domestic uses and applications of Fienza® products, such as private residential dwellings and retirement villages.

Commercial Warranty Periods

Applies to commercial uses and applications of Fienza® products, including, but not limited to: commercial food premises such as restaurants; commercial accommodation such as hotels; hospitals and healthcare facilities; public amenities; and industrial, laboratory and manufacturing facilities.

Product Component	Residential	Commercial
Ceramic Disc	5 years replacement parts, 1 year labour	5 years replacement parts, 1 year labour
Tap & Outlet (Structure Only)	5 years replacement parts or product, 1 year labour	5 years replacement parts or product, 1 year labour
Heads & Arms (Structure Only)	15 years replacement parts or product	7 years replacement parts or product
Finishes - Chrome	15 years replacement parts or product, 1 year labour	15 years replacement parts or product, 1 year labour
Finishes - PVD	10 years replacement parts or product, 1 year labour	1 year replacement parts or product, 1 year labour
Finishes - Electroplated	5 years replacement parts or product, 1 year labour	1 year replacement parts or product, 1 year labour
Accessories & Spare Parts	1 year replacement parts or product	1 year replacement parts or product

*Excludes parts subject to wear and tear such as rubber seals. Labour is not included unless otherwise specified.

Australian Consumer Law

Our products come with guarantees that cannot be excluded under the Australian Consumer Law. You are entitled to a replacement or refund for a major failure upon inspection by an authorised representative where a product is found to be defective in construction, material or assembly. You are also entitled to have the goods repaired or replaced if the goods fail to be of acceptable quality and the failure does not amount to a major failure, free of charge.

Warranty Conditions

- Installation has been carried out by a licensed plumber in accordance with AS/NZS 3500 and all applicable local regulations and plumbing codes.
- All maintenance and adjustments to the product after the installation have been carried out by a licensed plumber.
- Cleaning and care instructions detailed in this document have been strictly adhered to.
- Proof of purchase is required for warranty claims.

Warranty Limitations

To the extent permitted under the Trade Practices Act and other relevant legislation, Fienza's liability is limited to:

- The cost of replacing the goods, or
- The cost of obtaining equivalent goods, or
- The cost of having the goods repaired
- Fienza is not responsible for any lack of operation or performance of goods (or any loss or damage) where goods are used or adapted for use with other goods not supplied by Fienza.
- It is the responsibility of the customer and installer before installation to ensure that all components are correct and free of obvious visible faults.
- Fienza is not responsible for the labour and rectification costs incurred in the above circumstance.

Conditions for On-Site Warranty Service Calls

Fienza will charge a service fee for each visit to an installation by its technician where it is determined that the fault is due to poorly executed or unlicensed installation work or where the product is not a genuine Fienza product or where the product is outside the warranty period. This may be paid in advance by credit card over the phone to a Fienza technician attending the site and will be refunded if the Fienza product is found to be at fault.

PLEASE LEAVE THIS MANUAL WITH THE END USER

For warranty support, please contact Fienza

2 Bailey Court, Brendale QLD 4500 PO Box 5381, Brendale QLD 4500

P 07 3490 6700 F 07 3490 6719 E help@fienza.com.au ABN 76 136 411 311