

# REF. LD233

## 3+3 double wide chest

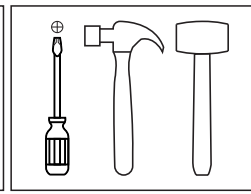
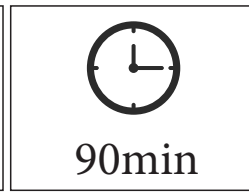
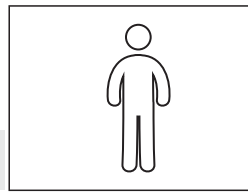

Thank you for choosing this furniture.

**BEFORE YOU START ASSEMBLY** please store the carton at room temperature for 48 hours or more so the contents can acclimatise.

**PLEASE RETAIN ALL PACKING UNTIL YOU HAVE COMPLETED ASSEMBLY.**

### Information about your furniture.

This furniture has been manufactured from surface coated wood based manufactured boards.

### Caring for your furniture.

Extreme temperature can cause slight movements in the board material so please avoid placing your furniture close to radiators or other sources of heat.

Please avoid exposing your furniture to continued bright sunlight as this can affect the colour, any fluid spills should be removed as quickly as possible

Always lift your furniture when moving as dragging may cause damage to your furniture or flooring.

Use mats or coasters to help protect against heat.

Do not stand on your furniture .

### Aftercare.

Wipe all surfaces with a dry cloth and the occasional use of a normal household furniture Polish, do not use detergents or chemicals on your furniture.

After assembly remove any visible component identification stickers, these should remove easily however any remaining adhesive residue can be removed with a label adhesive removal liquid available from most DIY or hardware stores.

For models with drawers we also recommend you use a household spray polish or curtain track spray on the drawer runner tracks. Please do not use any wax based products, chemicals or detergents on this furniture.

Regularly check all fixings to ensure they are tight.

### **BEFORE YOU START ASSEMBLY**

Please check that you have all the correct parts and fittings as detailed on the assembly instructions.

We recommend that you build your furniture on top of a soft clean cover to ensure the unit does not get marked or damaged during assembly.

**FOR DAMAGED/REPLACEMENT PARTS** Please visit

[www.coreproducts.co.uk/parts](http://www.coreproducts.co.uk/parts)

BATCH NUMBER





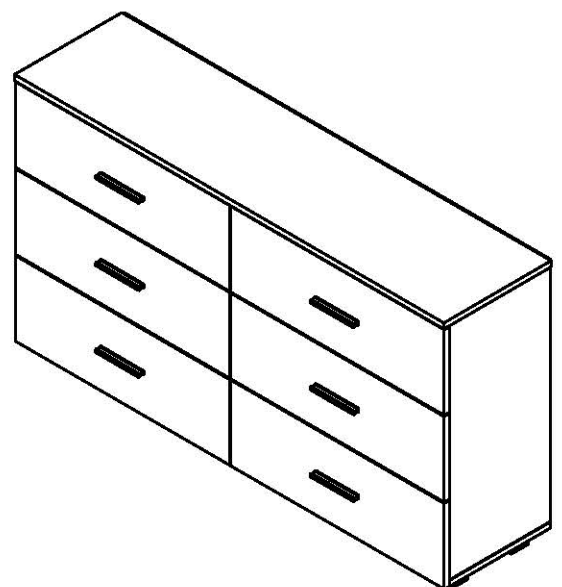



KAIFU7151

Height:685mm  
Width:1200mm  
Depth:300 mm

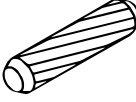

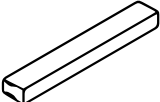
**PLEASE RETAIN THIS LEAFLET ALONG WITH YOUR DELIVERY  
NOTE / RECEIPT FOR FUTURE REFERENCE.**

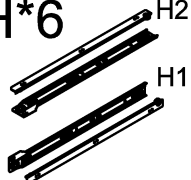
# ASSEMBLY HARDWARE

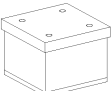
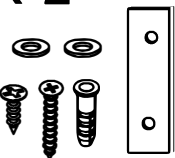
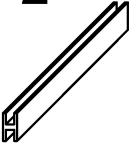
<b>A*46</b>  40 mm	<b>B*46</b>  15 mm	<b>C*18</b>  8*40 mm	<b>D*72</b>  3.5*14 mm	<b>E*28</b> 	<b>F*6</b> 
<b>G*12</b>  3.5*18 mm	<b>H*6</b>  250 mm	<b>I*30</b>  3.5*35 mm	<b>J*6</b> 	<b>K*2</b> 	<b>L*2</b> 

## ASSEMBLY PARTS

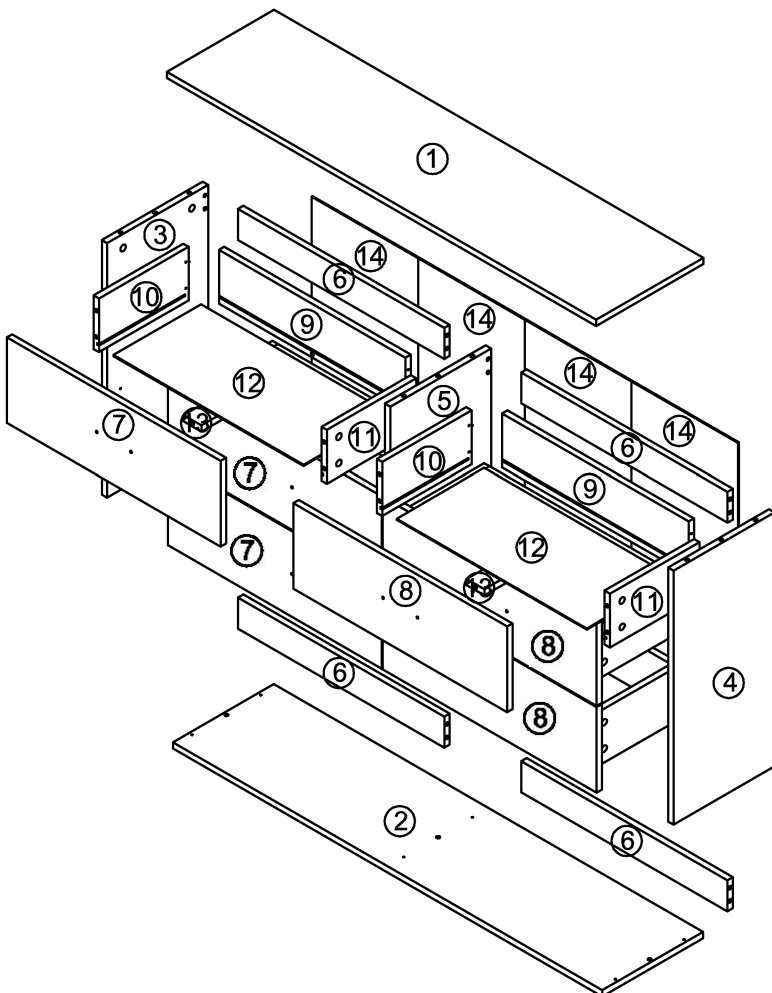

## MAX SUGGESTED LOADS

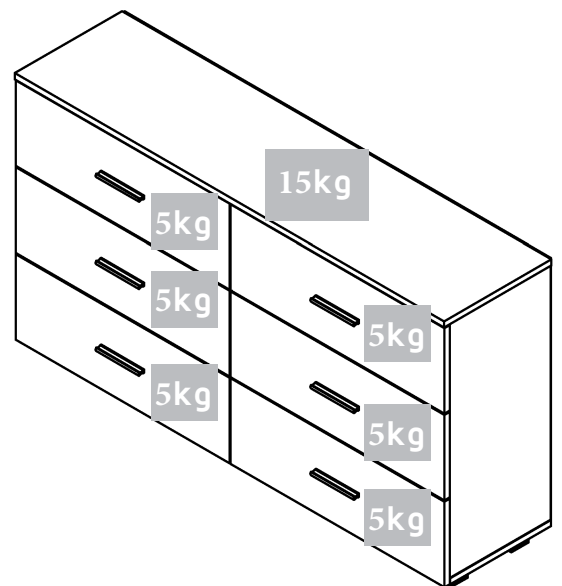

1

A\*6



40 mm

C\*3

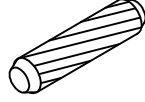

8\*40 mm

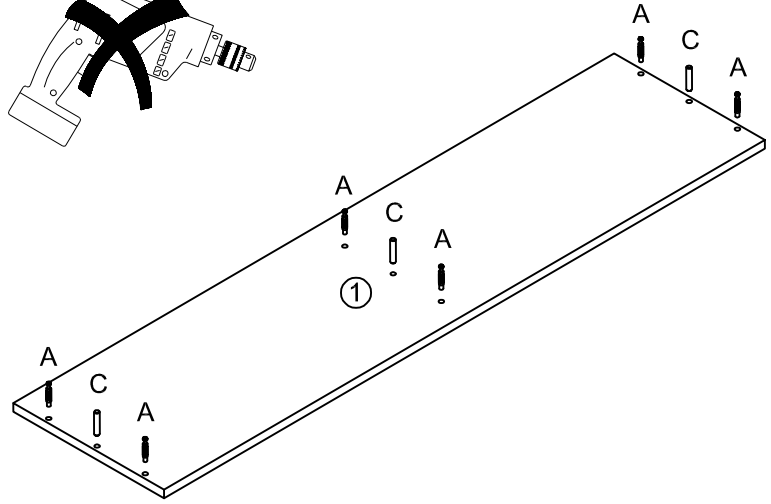
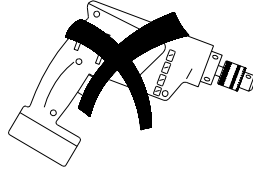

2

A\*16



40 mm

C\*3

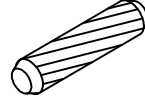

8\*40 mm

D\*24



3.5\*14 mm

H\*6

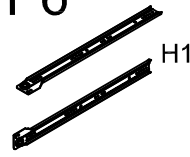

250 mm

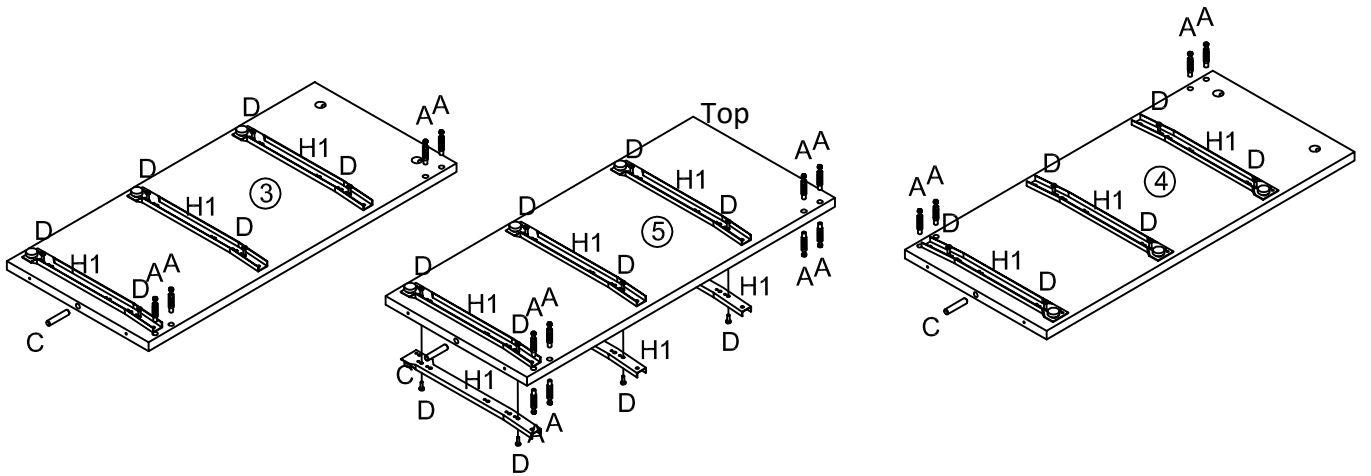
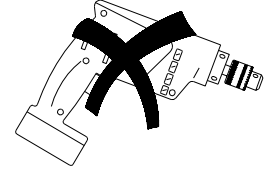

3

B\*16

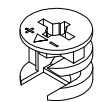

15 mm

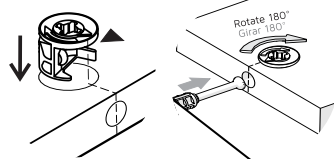

Turn minifix cams to the right to tighten.

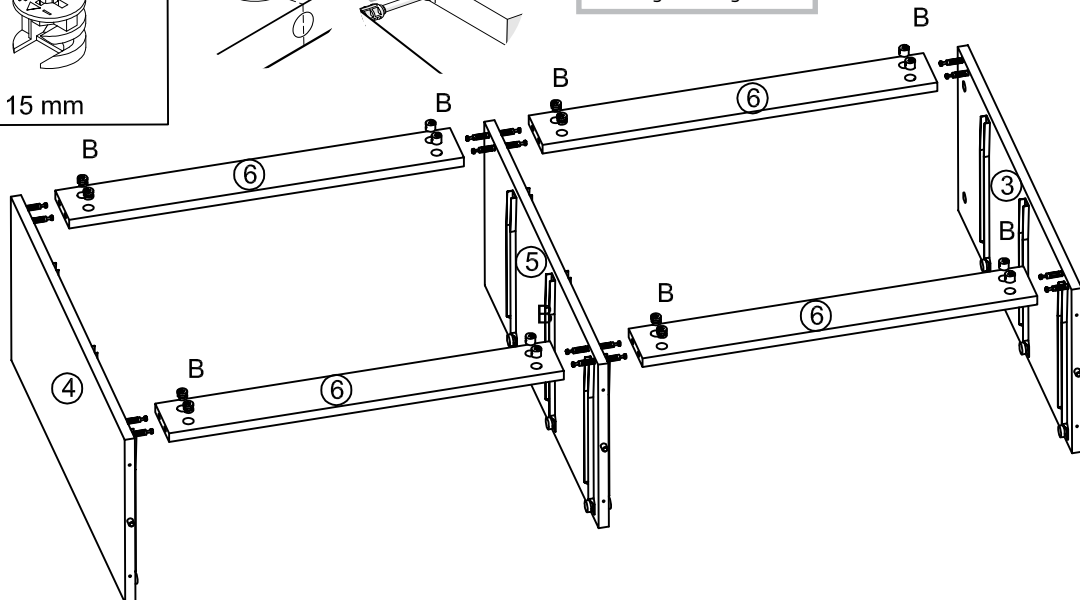

4

I\*6

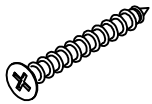

3.5\*35 mm

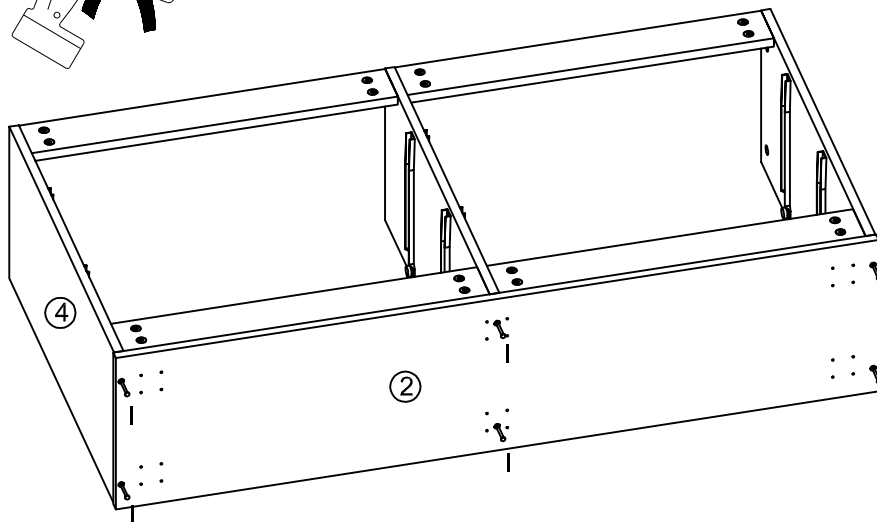
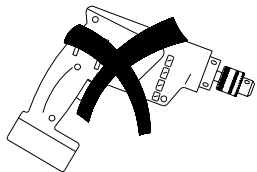

5

D\*24



3.5\*14 mm

J\*6

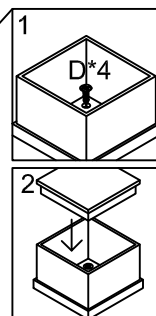
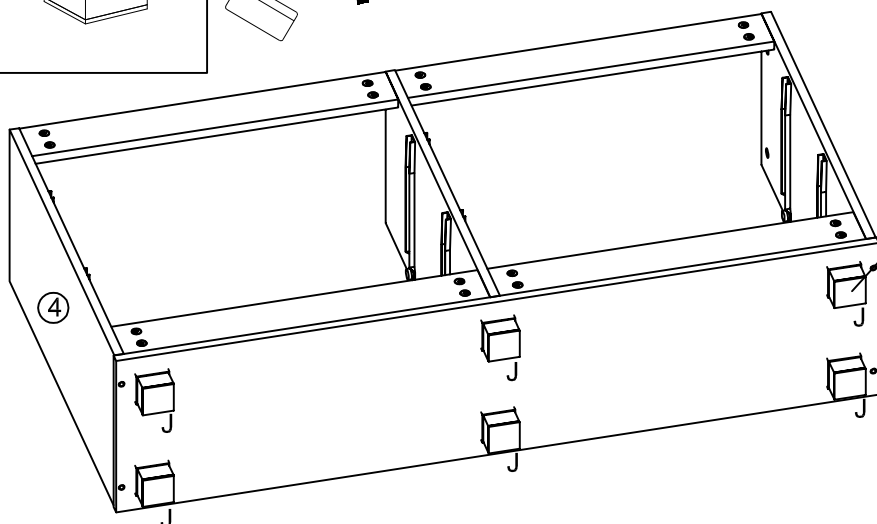
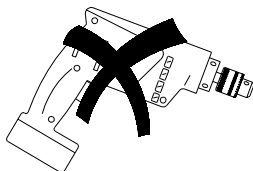
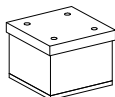

6

B\*6



15 mm

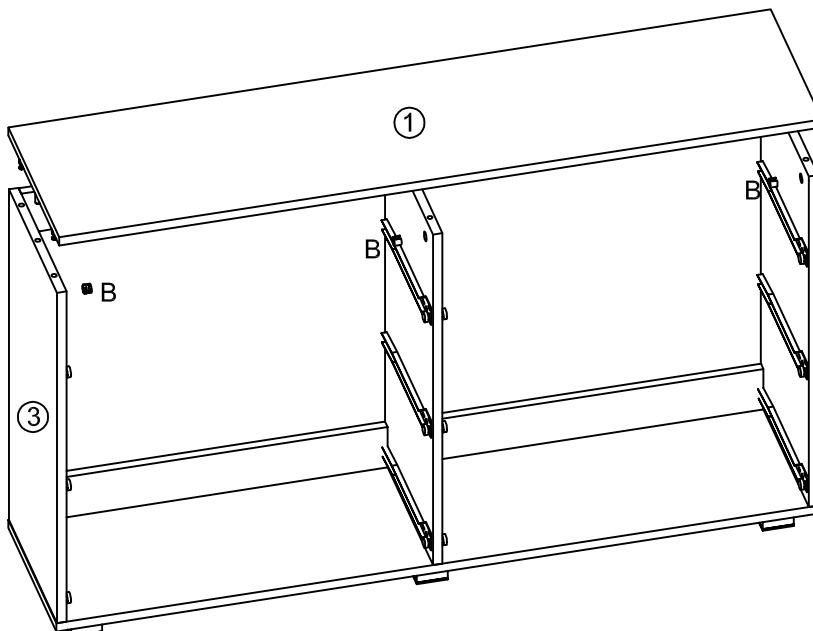

7

E\*28



L\*2

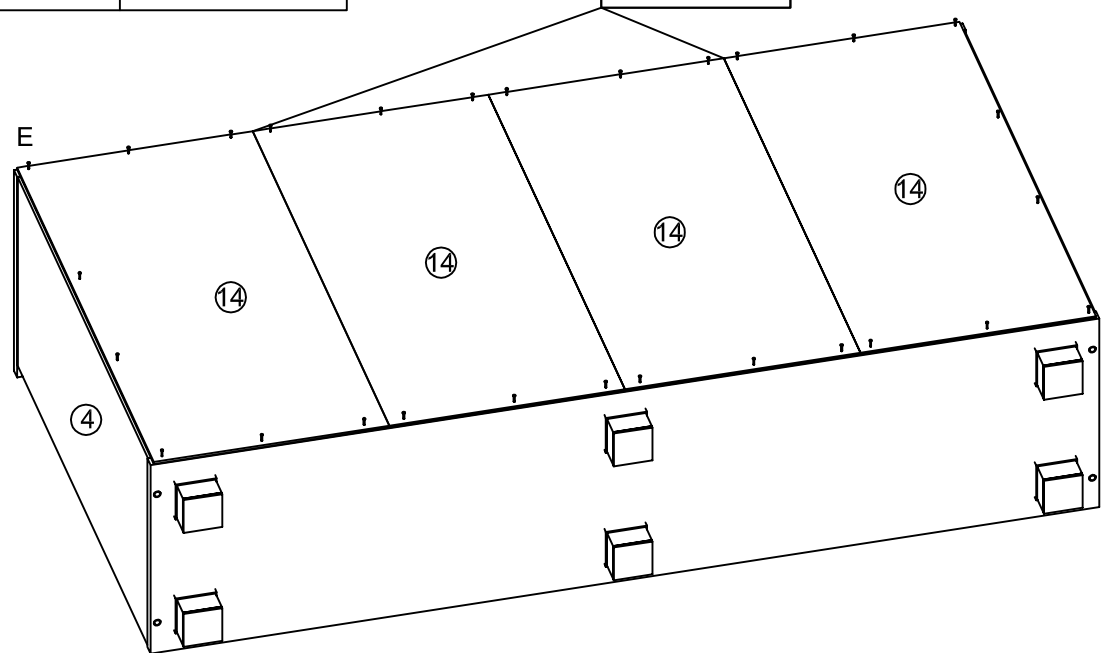
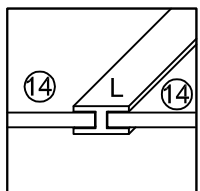
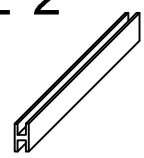

8

A\*24



40 mm

C\*12

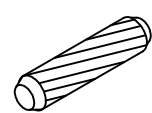

8\*40 mm

F\*6

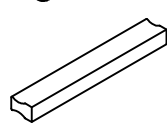

G\*12



3.5\*18 mm

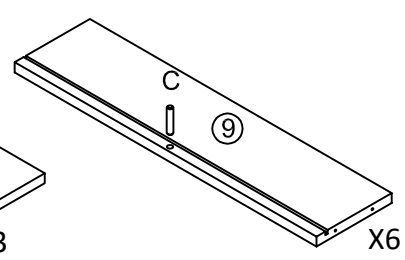
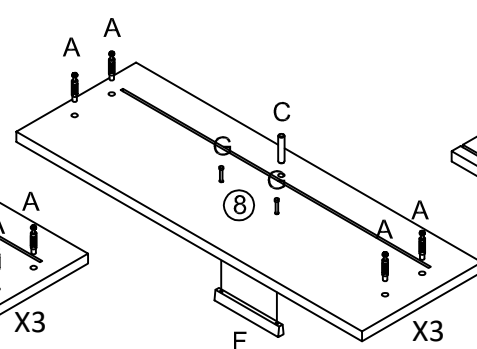
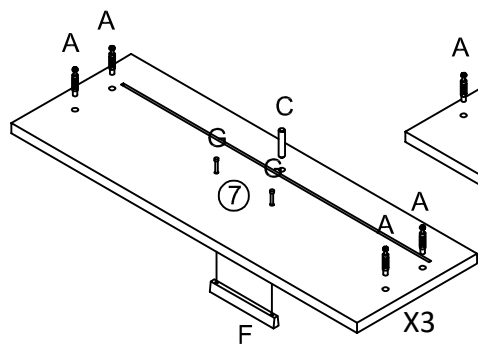
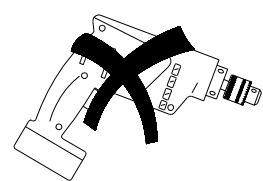

10

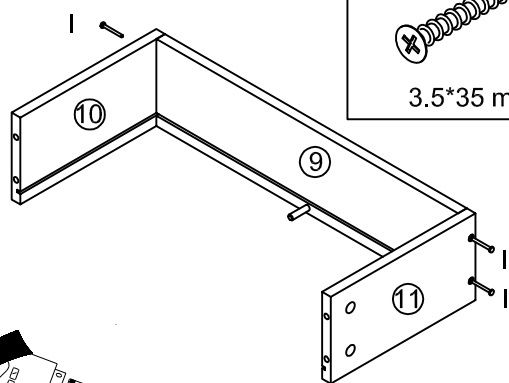

I\*24

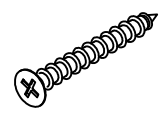

3.5\*35 mm

11

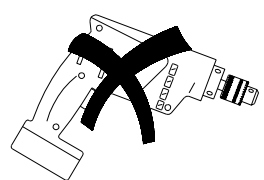
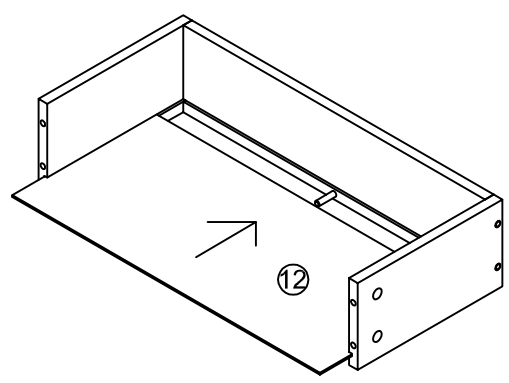

x6

x6

12

B\*12



15 mm

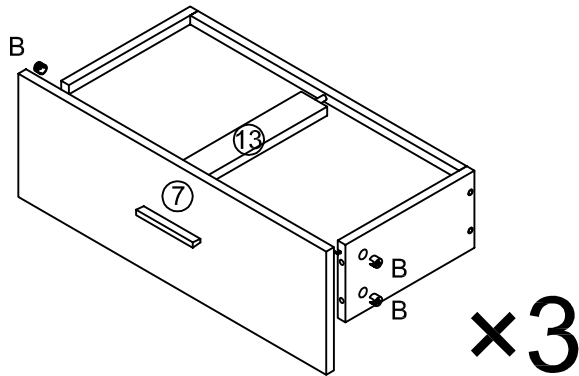

13

D\*12



3.5\*14 mm

H\*3

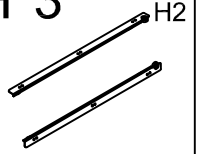

250 mm

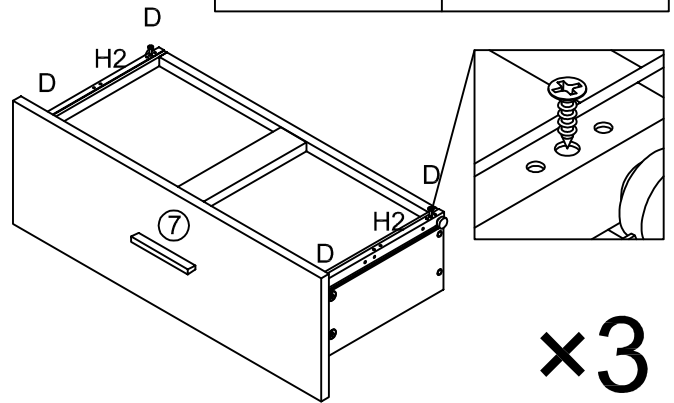

14

B\*12



15 mm

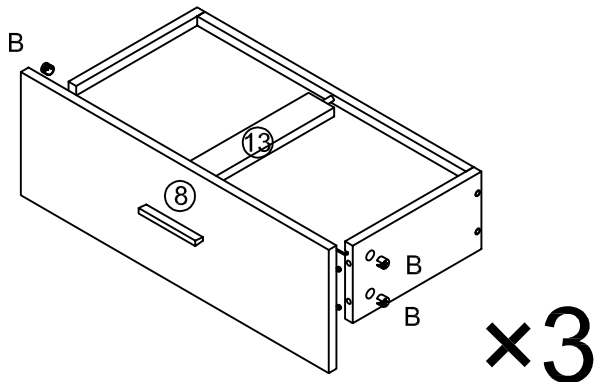

15

D\*12



3.5\*14 mm

H\*3

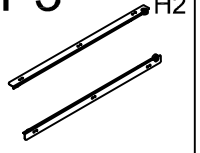

250 mm

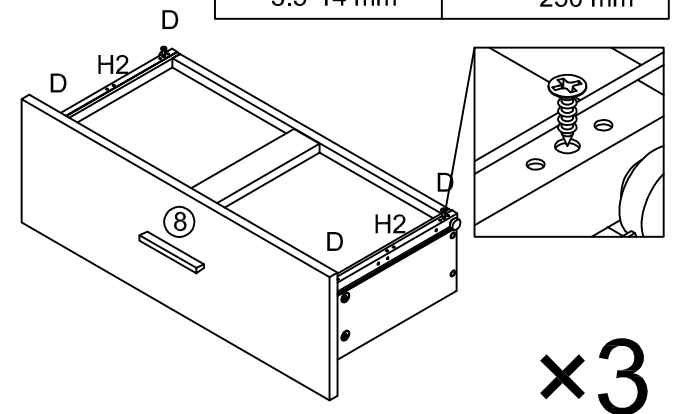

16

Angle the drawer slightly to ensure that the wheel at the back of the drawer slide goes behind the front wheel on the cabinet slide. Then lift the drawer up and slide it into the channel of the drawer slide.

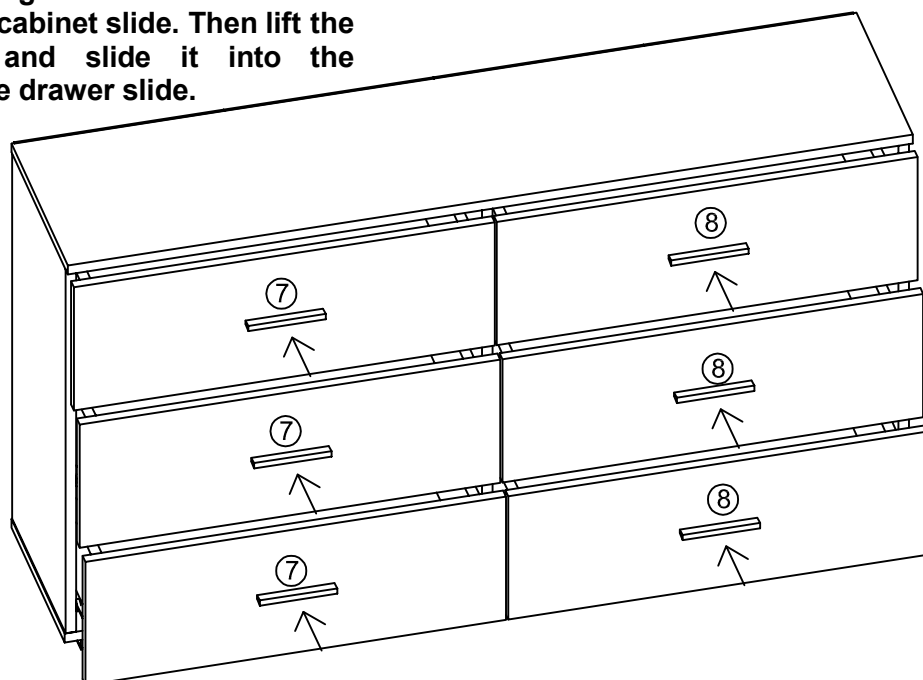
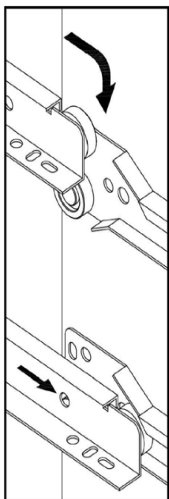

17

K\*2

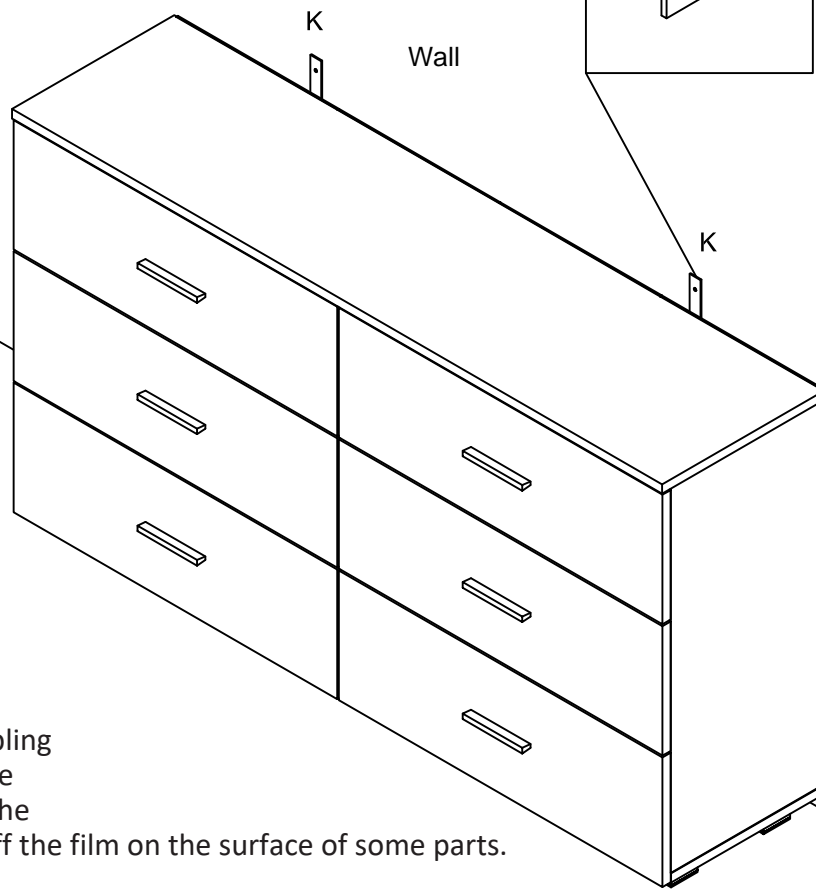
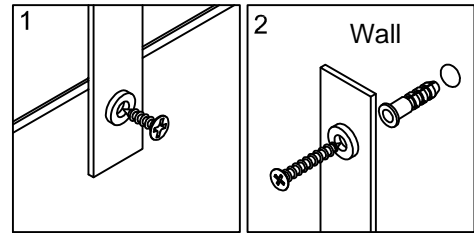
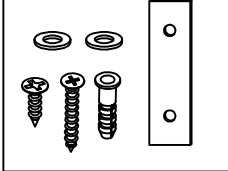

1

After you finish assembling the cabinet, take off the adhesive numbers on the parts' edge. And peel off the film on the surface of some parts.

## IMPORTANT NOTICE

Please avoid opening all drawers and doors simultaneously as this could cause your furniture to fall forwards.

Where there is a risk of this occurring, especially in environments with children or uneven floors.

We recommend that this item is attached to your wall using the fittings supplied.