

a25.3

integrated amplifier

user's manual

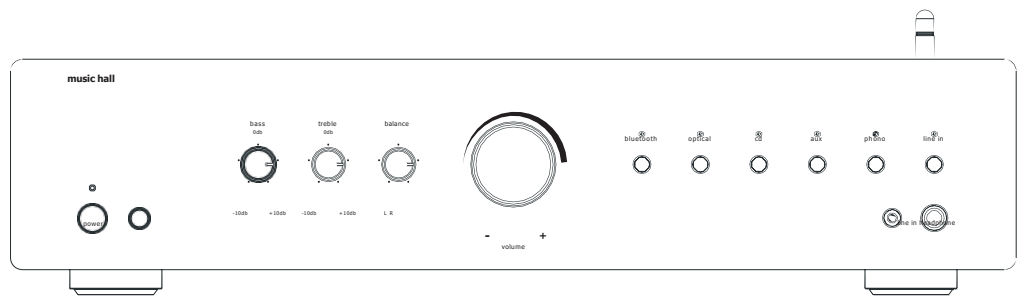

a25.3 integrated amplifier

music hall

<http://www.musichallaudio.com>

Congratulations On Your Purchase

You have selected a state-of-the-art integrated amplifier. Each component chosen for assembly in the construction of the Music Hall a25.3 was selected to provide you with superior performance and the highest level of sound reproduction available today. We know of no integrated amplifier that costs as much to produce that sells for so little. Please take a few moments to read over the instruction manual to ensure that you get the best performance from your unit and years of trouble-free service.

SAFETY GUIDELINES

This product is designed and manufactured to strict quality and safety standards. However, you should be aware of the following installation and operation precautions:

1. Take heed of warnings and instructions

Read all the instructions before connecting or operating the unit.

Keep this manual so you can refer to these safety instructions. Heed all warnings and safety information in these instructions and on the unit.

2. Water and Moisture

To reduce the risk of fire or electric shock, do not expose the unit to moisture or water. If the unit is exposed to moisture, immediately disconnect the power cord from the wall. Take the unit to an authorized music Hall service center for inspection. Do not touch the unit, power cord, or plug with wet hands.

3. Object or liquid entry

Do not allow foreign objects or liquids into the unit. If this happens, immediately disconnect the power cord from the wall and take the unit to an authorized Music Hall service center for inspection.

4. Ventilation

Please allow 2 inches (5 cm.) of unobstructed clearance around the unit. Do not place the unit on a bed, sofa, rug, or similar surface that could block ventilation from the bottom. Do not stack another component on top of the amplifier. If the component is placed in a bookcase or cabinet, it must be ventilated to allow proper cooling.

5. Heat

Keep the unit away from naked flames, radiators, heat registers, stoves, or any other heat-producing appliances (including amplifiers).

6. Climate

The unit has been designed for use in moderate climates. Do not attempt to use below 41 degrees Fahrenheit (5 degrees Celsius) or above 95 degrees Fahrenheit (35 degrees Celsius).

7. Rack and Stands

Place the unit on a fixed, level surface strong enough to support its weight. Do not place it on a moveable cart that could tip over. We recommend only using stands approved for use with audio equipment.

8. Cleaning

Unplug the unit from the mains supply before cleaning. The case should normally require only a wipe with a soft lint-free cloth.

9. Power Sources

Only connect the unit to a power supply of the type and voltage described in the operating instructions or specified on the rear panel of the unit.

10. Power cord protection

Connect the unit to the power outlet only with the cord supplied. Do not modify the supplied cable in any way. Do not attempt to defeat grounding and/or polarization provisions. Do not use extension cords. Do not route the power cord where it will be crushed, pinched, bent at severe angles, exposed to heat, or damaged in any way.

11. Non-use periods

If the unit is to be left unused for a long period of time, the power cord should be unplugged from the wall outlet.

12. Damage Requiring Service

Stop using the unit immediately and have it inspected by an authorized Music Hall service center whenever:

1. The power supply cord or plug has been damaged.
2. Liquid has been spilled into the unit.
3. The unit has been exposed to rain.
4. The unit does not operate properly.
5. The unit has been dropped or damaged.
6. Smoke or any unusual smell is detected from the unit.

CAUTION: TO REDUCE THE RISK OF ELECTRIC SHOCK, DO NOT REMOVE COVER. NO USER-SERVICEABLE PARTS INSIDE. REFER SERVICING TO QUALIFIED SERVICE PERSONNEL.

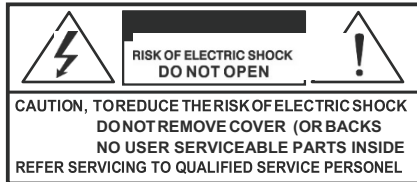

Indicates that the user of this unit must understand important operation and maintenance instructions.



Indicates high-voltage power inside the unit, which will cause electric shock.

Getting Started

Thank you for purchasing the Music Hall a25.3 The a25.3 is a classic two-channel integrated amplifier designed for the music lover. We chose a select group of technologically advanced components to create this powerful 75 watt/channel into 4 Ohms and 50 into 8 ohms, integrated amplifier. It also has an optical input and a Bluetooth receiver. When used in a top-end audio system, your music Hall integrated amplifier will provide years of enjoyment. The a25.3 is the perfect complement to Music Hall's cd25.3 cd player.

A Few Precautions

Please read this manual carefully. In addition to installation and operating instructions, it provides valuable information that will help you get optimum performance from your system. Please contact your authorized Music Hall dealer for answers to your questions. In addition, all of us at music Hall welcome your questions and comments. Save the **shipping carton and all enclosed packing material for future** use. Shipping or moving the unit in anything other than the original packing material may result in severe damage that is not covered by the warranty. Be sure to keep the original sales receipt. It is your best record of the date of purchase, which you will need in the event warranty service is required.

Placement

Use common sense when placing the a25.3. Always place it on a firm, level surface. Be sure that the shelf or cabinet can support the weight. Ensure that there is adequate ventilation around all sides of the unit. Avoid placing the a25.3 where it may be subject to excessive heat, such as near a heat register. Do not place anything on top of it. For best performance, avoid placing the a25.3 where it may be subject to vibration, such as near a speaker.

Connecting Source Components to the a25.3

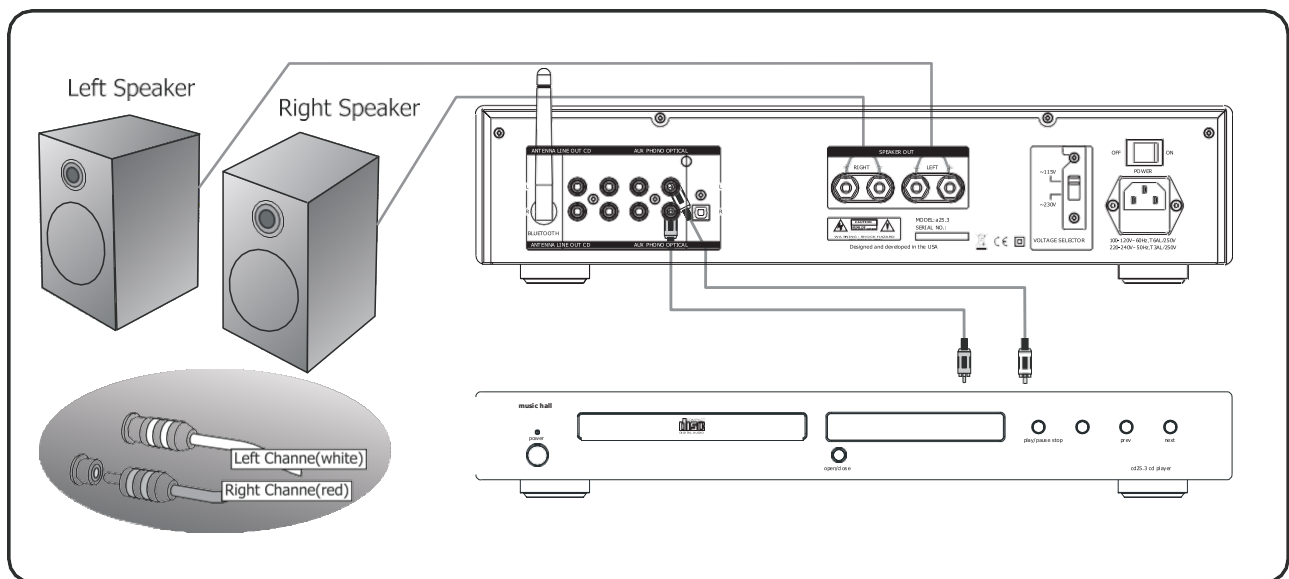

Back Panel and Connections

OPTICAL: Connect the amplifier to the digital output on your CD player / computer / games console / network player, etc. by using an optical digital audio cable.

PHONO: For connection to a turntable with a MM (moving magnet) phono cartridge. (Note: Ground Screw next to inputs)

INPUTS CD/AUX: For connection of optional equipment

LINE OUT: For connection to an external amplifier or sub-woofer

ANTENNA: Connection for Bluetooth, keep it vertical.

SPEAKER OUT (R AND L): For connection to loudspeakers see additional instructions below.

VOLTAGE SELECTOR: Before connecting, insure that the voltage selector is set for the correct voltage for your region. (115v USA) or (230v European)

POWER SWITCH: Switches the device on and sets it in the standby mode. If the switch is set to the "OFF" position, the device is disconnected from the mains supply.

AC IN: For connection of mains voltage. Make sure that the plug is correctly inserted, and that the voltage corresponds to the text printed on the cabinet back panel.

Speaker Outputs

To avoid damage to the a25.3, make sure it is **NOT** plugged into an AC outlet while connecting up or disconnecting speaker wire to the speaker outputs. The a25.3 has one pair of speaker outputs on the back labeled **+ R** (right speaker) and **L +** (left speaker). Use a suitable pair of speaker cables for connecting the speakers. Consult with your dealer if you need advice.

Connect the right speaker to the R connectors and the left speaker to the L connectors. Pay careful attention to match the positive (red or +) connector on your speaker to the positive (+) terminal on the a25.3. Likewise, match the negative (black or -) speaker connector to the negative (black or -) terminal on back of the a25.3. This will insure your loudspeakers are playing in phase.

Connecting to the Mains - Plugging In

Check that the on/off button on front of the a25.3 is in the **off** position. Push the plug (IEC line socket) of the power cable supplied with the a25.3 into the socket (AC IN) on back of the unit. Make sure it is pressed in firmly. Plug the other end of the power cable into an AC wall outlet.

Operating the a25.3

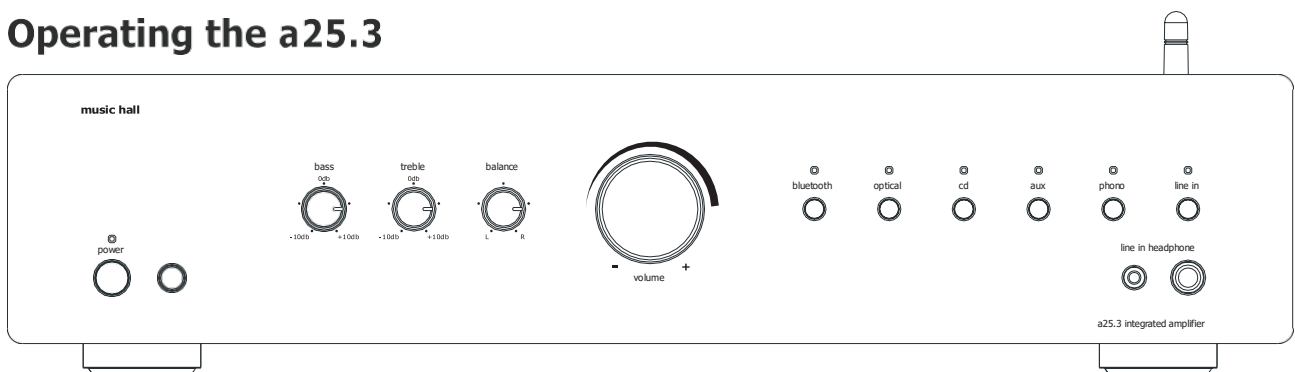

push the power button to turn on the a25.3. select your desired source via the push buttons on the front panel, adjust volume, and enjoy.

led status indication: If the led is illuminated blue: the a25.3 is switched on indicating that the device is ready for use.

If the led is illuminated red, the a25.3 is in standby mode.

line in: additional input that accepts a 3.5mm stereo connector

The 6.3 mm stereo output jack is for headphones. The speakers are deactivated when this jack is used. Please set the volume to a low level before connecting the headphones.

bass/treble. The bass and treble knobs can be used to enhance or diminish

bass or treble. Balance knob can adjust the level of the right or left channels

Remote Control Functions

The supplied remote controls both the a25.3 integrated and the cd 25.3 cd player. The a25.3 functions are:

- ① turn on the device or enter standby mode
- ② mutes the integrated amplifiers output
- ③ adjust volume up or down
- ④ backwards, pauses, playback, forwards track using bluetooth
- ⑤ to select an input source, toggles through inputs
- ⑥ pairing equipment using bluetooth

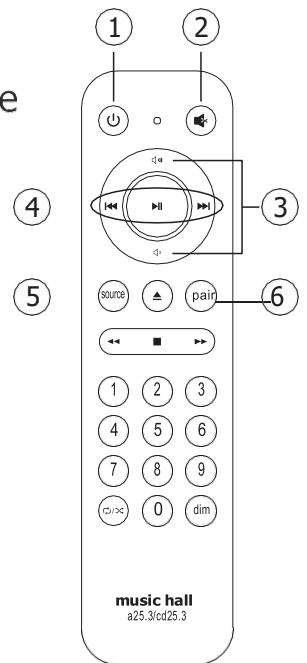

Install the batteries before use.

Technical Specification

Input sensitivity	RCA: 0.65V Phono (NNI): 5mV
Power output	50W@8ohm 75W@4ohm
LINE OUT	0.65V
SNR	>90dB
THD+N	<0.02%(20Hz-20KHz)
Frequency response	RCA: 20Hz-20KHz(-0.5dB) PHONO: RIAA compliant
Analog inputs	3 x line level, 1 x phono
Digital inputs	1 x optical level, 1 x bluetooth level

Physical

Dimensions	w16.9 x d12.6 x h3.5 in. (w430 x d321 x h90 mm)
Weight	14.3 lbs. (6.5 kg.)
Supplied Accessories	power cord, remote control, 2 x AAA batteries

USA This product complies with FCC requirements

Troubleshooting

No LED indicating Volume or Source

Check:

- that the power switch is on
- that the power cord is connected securely
- that there is power at the wall outlet
- the fuses after unplugging the power cord

No Sound

Check:

- that the volume control isn't at zero
- that the unit is not in "mute" mode
- the selected input is playing
- the headphones are unplugged
- all interconnect cables are making good connection
- speaker wires are securely connected

Weak Bass/Confused Stereo Image

Check:

- that the speaker wiring is in phase (positive on the speaker connector is connected to positive on the amplifier and likewise for the negative)
- confirm that all speaker and interconnect cable connections are secure

Distorted Sound

Check:

- that the volume isn't too high

Remote Control not functioning

Check:

- that there are no obstacles between the remote and the unit
- that the batteries are fresh and not expired

Guarantee

This entitles you to have the Music Hall a25.3 repaired or replaced, at our discretion, free of charge for one year after purchase, at any authorized Music Hall dealer, provided the unit was purchased from an authorized dealer. Your original sales receipt is used as proof of purchase date. Music Hall can take no responsibility for defects arising from accident, misuse, abuse, wear and tear, neglect or through unauthorized repair and or adjustment. Neither can Music Hall accept responsibility for damage or loss occurring during transit to or from the person claiming under the guarantee.

Warranty

Your Music Hall a25.3 warranty covers parts and labor costs for one year from the purchase date. After one year, you must pay for both parts and labor costs. The warranty does not cover transportation costs at any time.

Claims under guarantee

The unit should be packed in the original packing and returned to the dealer from whom it was purchased, or to an authorized Music Hall service center. It should be sent by a reputable carrier, carriage prepaid. Do not send the unit via USPS (United States Postal Service). No responsibility can be accepted for the unit while in transit to the dealer, customer, or authorized service agent, therefore, customers are advised to insure the unit against loss, damage, or theft while in transit.

For further details contact Music Hall LLC:

108 Station Road

Great Neck, NY 11023

T: 516.487.3663

F: 516.773.3891

W: <http://www.musicHallaudio.com>
