

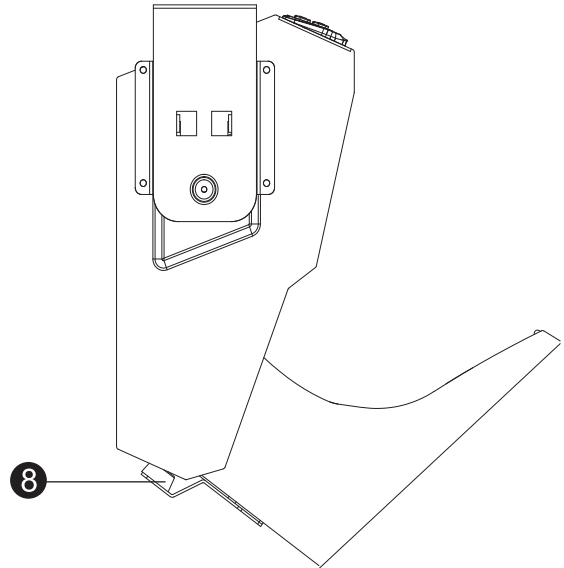

**Desk Mounted Firearm Safety Device
Instruction Manual (RP311E)**

RPNBSafe delivers security exactly where you want it.

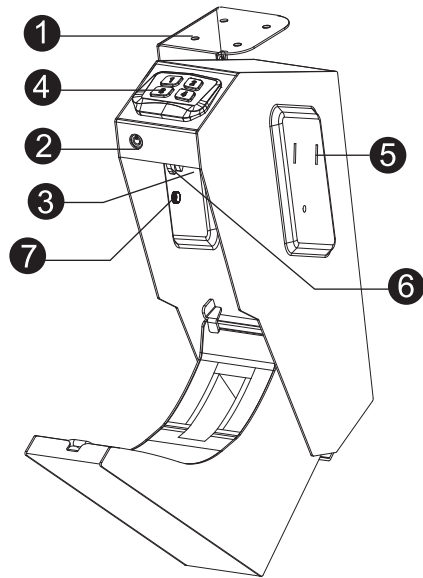

- ① Mounting Bracket
- ③ Battery Compartment
- ⑤ Holes Of Mounting Hook
- ⑦ Thumb Screw
- ⑨ Hardware Mounting Kit

- ② Emergency Keyhole
- ④ Panel (Buttons)
- ⑥ Reset Button
- ⑧ Rubber Bumper
- ⑩ Backup Keys (2)

Warnings

To prevent damage to your RPNB® unit or injury to yourself or to others, read the following safety precautions before using this unit.

**DO NOT PLACE OR STORE THE BACKUP KEYS INSIDE THE SAFE AT ANY TIME.
IF THE BATTERY FAILS, YOU WILL BE UNABLE TO OPEN THE SAFE.**

DO NOT expose to extreme heat or cold. Battery power may be affected.

DO NOT store loaded guns in this unit. Firearms are serious in nature and must be handled with respect. Store responsibly.

ALWAYS check to make sure door has latched when closing; Lid requires a firm press and locks automatically.

Disclaimers:

Neither seller nor manufacturer shall be liable for unauthorized access, any injury, loss or damage to personal property direct or consequential, arising out of the use of, or the inability to use the RPNB® Safe.

The user shall determine the suitability of the RPNB® Safe before the intended use and user assumes all risk and liability whatsoever in connection therewith, RPNB® Safe are not intended to protect against environmental hazards including fire and water.

Be sure and follow all local and state firearm laws.

DO NOT operate a firearm without proper training and experience.

Battery Installation

- 1 To get started, insert one of your backup keys into the keyhole at the front of the safe. Push key in and turn it counterclockwise to open the safe (see Figure A).
- 2 Locate the battery compartment door on the inside of the safe directly behind the keypad (see Figure B).
- 3 Open the battery cover and insert the 4 AAA alkaline batteries (not included) into the battery compartment. Note that pay attention to the "+" and "-" signs. The "-" end of the batteries go against the spring inside of the compartment.
- 4 Repeat above steps for battery replacement.

Battery Warnings

- Always insert batteries correctly with regard to polarity (+ and -) as marked on the battery and the product.
- Exhausted batteries should be immediately removed from product and properly disposed.

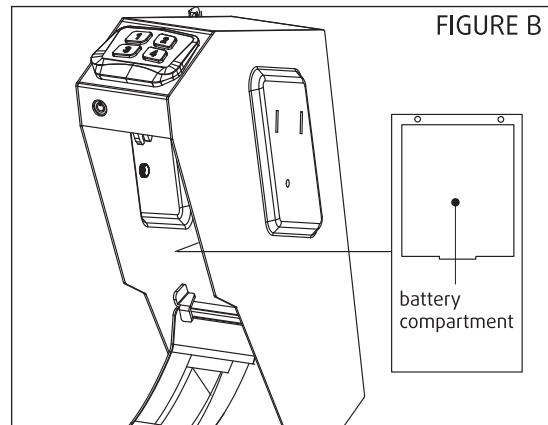
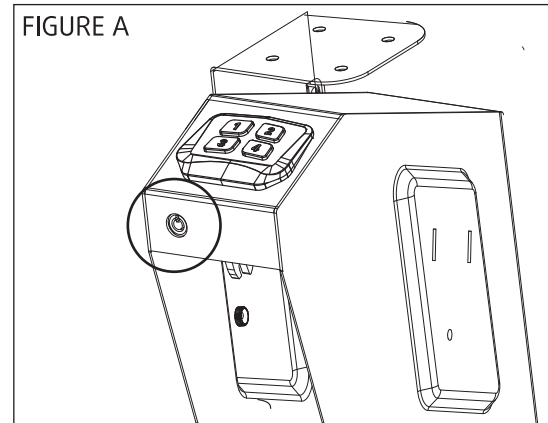

IMPORTANT: Your RPNB® safe will automatically lock when you fully close the lid.

Master Code Programming

First time users should change the default code as soon as possible to prevent unauthorized access to your safe, so it should be kept confidential.

TIPS: Code Requirements

- Your code can be a minimum of 4 and a maximum of 6 digits.
- Two keys cannot be pressed simultaneously.
- Programming a new code will overwrite your previous code.
- When you go into confirm password mode, attention please just press(not hold) the "PROGRAM" button "1" second and let it go(Don't press for too long).

- 1 Enter default code 1-2-3-4 on the keypad to open your safe.
- 2 With the safe open, press and hold the "PROGRAM" button (**3 seconds**), all keys(1-4) will flash blue two times with the double beeps.
- 3 Enter your NEW master code. Press(**not hold**) the "PROGRAM" button (**1 second**) and release it to confirm, all keys will flash blue two times with the double beeps. This tone confirms that the password has been reset.
- 4 If all keys flash red five times with five beeps, it means the safe failed to set the new master code, simply start over with step 2.

- Please keep your new master code in a safe place.

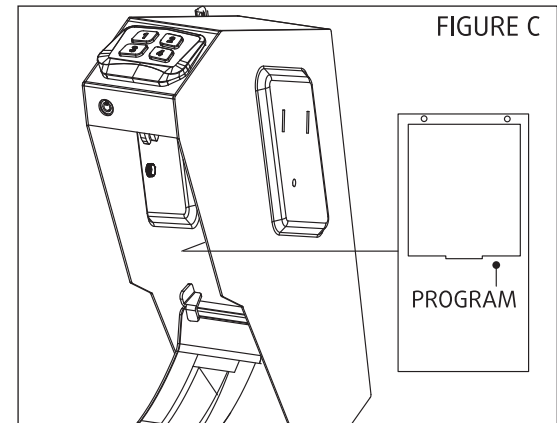

Lock-down System

- If the wrong code is entered five consecutive times, the safe will go into a lock-down mode for five minutes. During this time the buttons will flash red when pressing any buttons and the keypad will be temporarily disabled. The safe can still be opened using the backup keys override. After five minutes, the safe will automatically resume normal operation.

Low Battery Warning

If all keys will light up yellow 6 times with 6 times beeps when opening the safe by electronic way, your battery level is critically low and your safe needs to be replaced the 4 new batteries.

Silence Mode Setting

To silence the audible sound of the electronics, hold the “1” button for 3 seconds until all the buttons flash blue once together. To unmute the keys, repeat this step (see Figure D).

FIGURE D

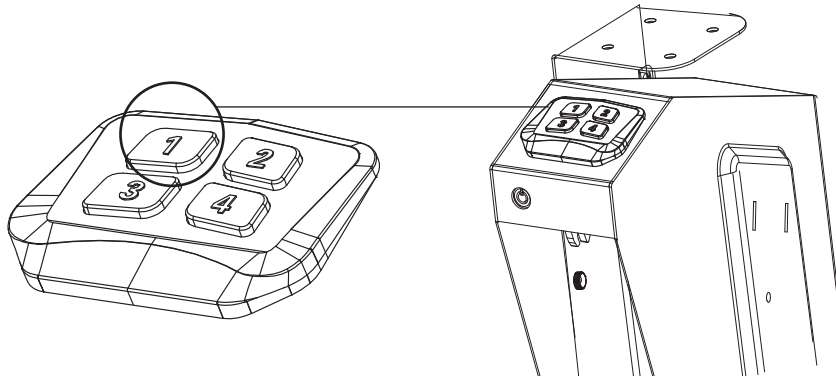

Mounting Your Safe

Use proper drilling tools and mounting hardware based on the type of surface you are mounting the safe onto. Supplied screws are intended to be used on wooden surfaces.

TIP: Make sure you have enough clearance for the lid to open properly before mounting the safe.

- 1 Open the safe with the master code or backup keys.
- 2 Unscrew the thumbscrews located on the inside of the safe (see Figure E).

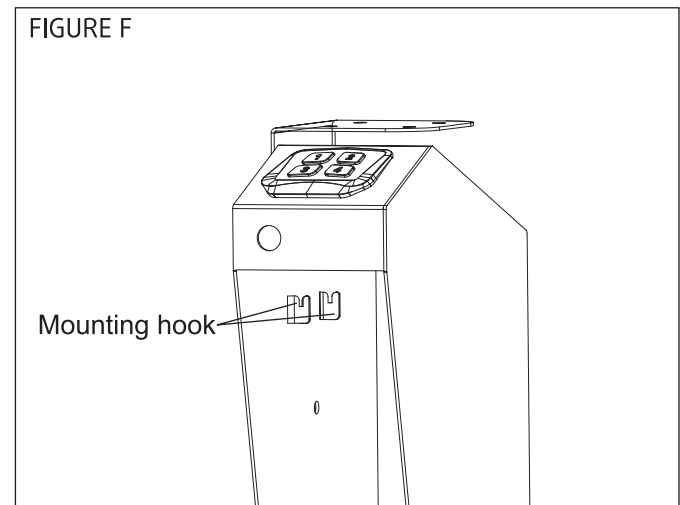
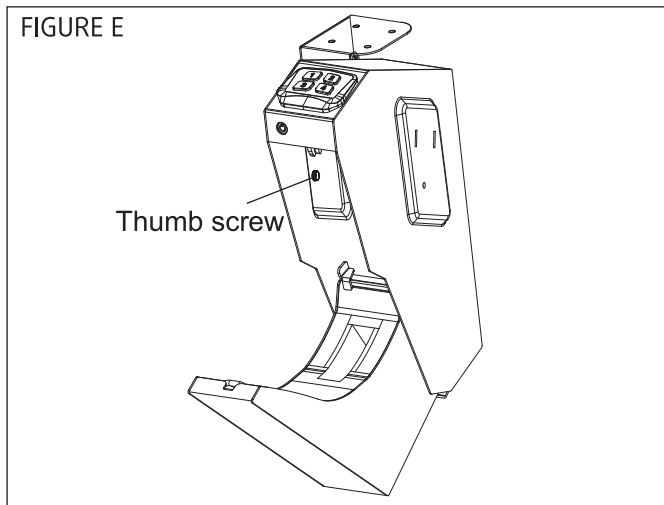

- 3 Remove the bracket by sliding it down and off the safe (see Figure F).

Mounting Your Safe

- 4 Use the wall mounting holes on the side or top of the mounting bracket to mark the desired mounting location (see Figure G).

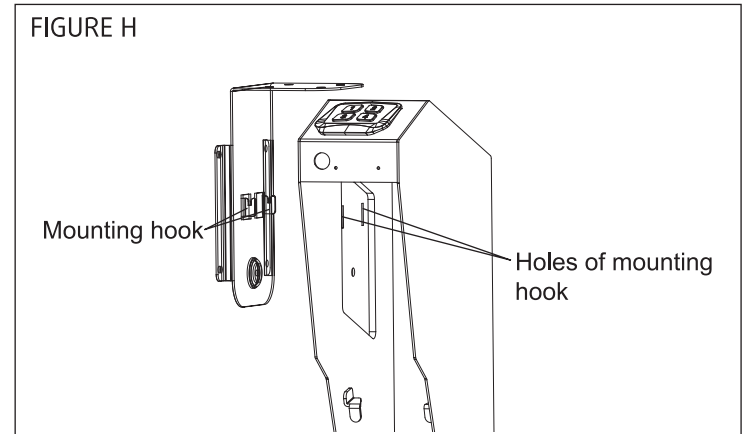
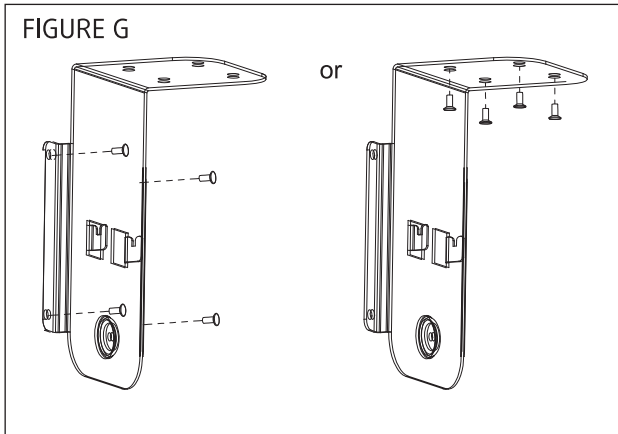

- 5 Use appropriate mounting hardware to screw the bracket to desired location.
- 6 Slide the safe onto the bracket mounting hook, fix the safe to the bracket with thumbscrews from inside the safe (see Figure H).
- 7 Close the safe.
- 8 The safe can be used now .

IMPORTANT

Do not let the safe door face the floor when you mounting the safe with the vertical direction to avoid your property from damage.

How shall I view tutorial videos?



RPNB[®]

<http://www.rpnbsafe.com>

- 1 Go to our website via: **www.rpnbsafe.com**
- 2 Select the "**Customer Service**" on the navigation bar
- 3 Click "**How To Video**"
- 4 Select the product model you purchased

How shall I replace keys?

- 1 Go to our website via: **www.rpnbsafe.com**
- 2 Select the "**Customer Service**" on the navigation bar
- 3 Click "**Replace Keys**"
- 4 Fill in the required information

How shall I order accessories?

- 1 Go to our website via: **www.rpnbsafe.com**
- 2 Select the "**Customer Service**" on the navigation bar
- 3 Click "**Order Accessories**"
- 4 Fill in the required information

 More online at www.rpnbsafe.com under support

Customer Support/Warranty

Customer Support

If you have a problem with your RPNB® safe that is not answered in this manual, we encourage you to email us: CUSTOMERSUPPORT@RPNBSAFE.COM

Linked Warranty (Terms and Conditions)

RPNB® is committed to building high quality products and will make every effort to ensure our products are free from any defects. We guarantee your safe will be free of defects in materials or workmanship for a period of one year from the date of original. This warranty does not cover abuse, misuse, use in any manner for which is not designed, neglect, modification, damage in advertently caused by the owner; accidents, and/or tampering.

If your safe is determined to be defective and we are responsible for the cause we will have it repaired at our expense, or we will send a new replacement at no cost to you. You will be required to return your existing unit as well as all included accessories to RPNB® prior to replacement of the defective unit along with your order of purchase.

If it is determined your safe needs to be returned our customer support team will provide you with a return detail.

Please have the following information available when contacting us:

- Purchaser's name and mailing address, email address, and phone number
- Online order number
- Detailed description of problem

NEITHER SELLER NOR MANUFACTURER SHALL BE LIABLE FOR ANY INJURY, LOSS OR DAMAGE, DIRECT OR CONSEQUENTIAL, ARISING OUT OF THE USE OF, OR THE INABILITY TO USE THE RPNB® SAFE.

How shall i talk to them?

Go to Your Orders, find your order in list, and click get product support.

You can e-mail the seller by doing the following:

Account&Lists Orders Try

Your Account

Your Account
Your Orders ←
Your Dash Buttons
Your Lists

Your Orders

Orders ← Open Orders Digital Orders

1 order placed in past 6 months ↕

Get product support →

Write a product review

Archive order

Talk to an expert

Figure out and fix what' s wrong,get s

phone chat →

if a new window doesn' t appear, chang

- 1.Go to your account find the order
- 2.Find your order item
- 3.Click get product support
- 4.Give the seller 24hours to respond

 Please email us to get a special **VIP** discount code before your next order.

 Problem with the order? Please email us, give us a chance to help you firstly.

 **Satisfied with us.**

Hum, this people is nice, i can give them a positive reviews to tell people they are selling good products, doing the right thing.



RPTB®

Dear Customer:
Thank for your business
— BEST WISHES FOR YOU —



Customer Support Hours:

Monday - Friday 9:00AM - 6:00PM (PST) Saturday - Sunday 9:00AM - 12:00PM (PST) Excluding Holidays
Hours subject to change

Customer Service Department Contact: customersupport@rpnbsafe.com