

FANTOM DOOR STOP

IMPORTANT INFORMATION:

Product contains a powerful magnet. Avoid contact with metal foreign bodies prior to installation. Keep well clear of electronics and electrical equipment. Carefully read Installation Instructions prior to installation. Installing contrary to these instructions risks damage to your floors and door.

Carpeted Surfaces: Allow sufficient clearance of carpet thread and pile when drilling hole into floor to avoid wrapping or binding to drill bit.

Tiled Surfaces: It is recommended to use a diamond coated drill bit to avoid chipping and damage of tiles.

1. Install Floor Insert Sleeve

1.1 Unpacking

- Remove top section only of packaging. Leave magnet in packaging for now.

Tools Required

Drill Bit 1/8"	Spade Bit 1"
Masonry Drill Bit 9/16" <i>*recommend diamond coated bit for tiled surfaces</i>	Phillips Head Driver
	Impact Drill
Silicone Gun + appropriate Sealant	

1.2 Select:

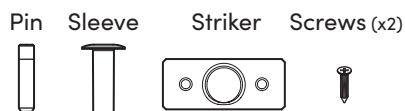

1.3 Mark Pin Location on Ground

- Open door to desired 'stop position'.
- Mark location on floor for pin as per diagram below.

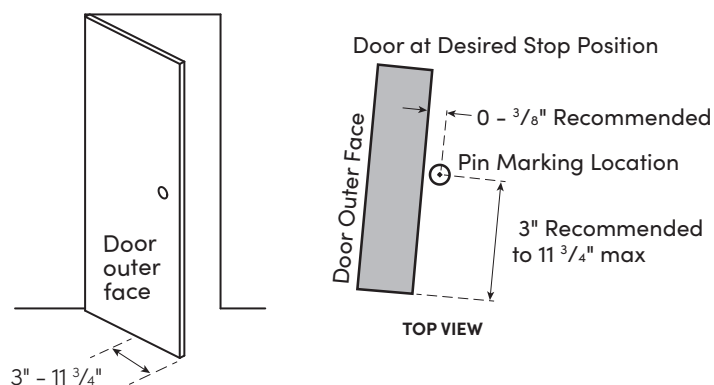

1.4 Install Sleeve & Pin

- Drill 9/16" hole, 2" deep.
- Trial fit Sleeve into hole and ensure it is a loose fit. Redrill if required.
- Clean hole and area.
- Apply silicone to Sleeve and insert into hole.
- Once dry, drop pin into Sleeve, chamfered edge first.

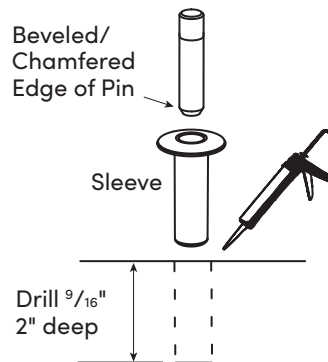

2. Install Magnet

2.1 Mark door for Striker Fitment

- Pass door over installed Pin.
- Mark on door where center of pin passes under door.

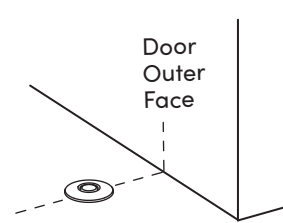

2.2 Drill Hole for Magnet

- Remove door from hinges.
- Stand door on edge with latch & knob upwards.
- Continue marking location from step 2.1 across bottom of door. Template overleaf can assist with this.
- Mark center line for drill location.
- Drill diameter 1" hole with spade bit 1" - 1 1/8" deep.

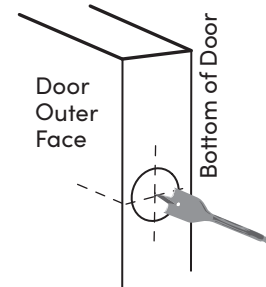

2.3 Drill Pilot Hole for Striker Screws

- Using the Striker as a template, or the template overleaf, position center of Striker into Magnet Hole.
- Drill 2 x 1/8" diameter holes, 3/4" deep.

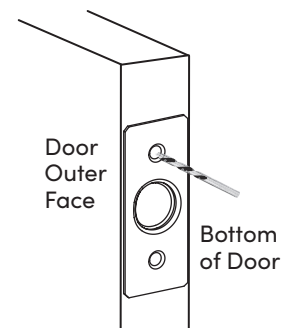

2.4 Fit Magnet and Striker Plate

- Carefully unwrap Magnet from packaging.
- ⚠ **WARNING. Powerful magnet, avoid any steel object within at least 8".**
- Place by hand immediately into hole.
- Fit Striker. **Deep edge of Striker MUST be on the Inner Face of door. If fitted in reverse, door stop will not function and damage may occur !!**
- Tighten Striker Screws.

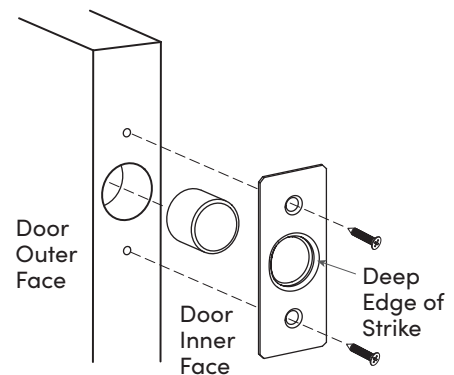

2.5 Rehang Door

- Correctly refit door.
- Test by opening door past the pin.
- You should see the door stopped/open as desired. Pull back on door to release.

