

Hinges
blum®

CLIP top BLUMOTION 155°
Straight-Arm Special Applications

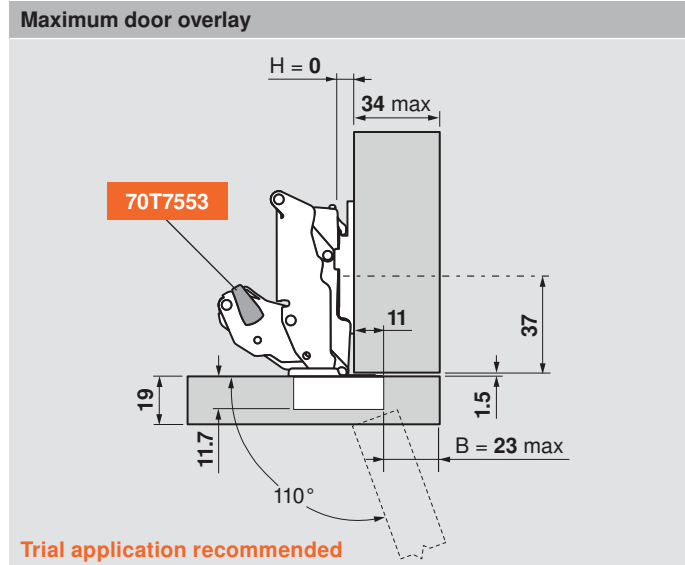
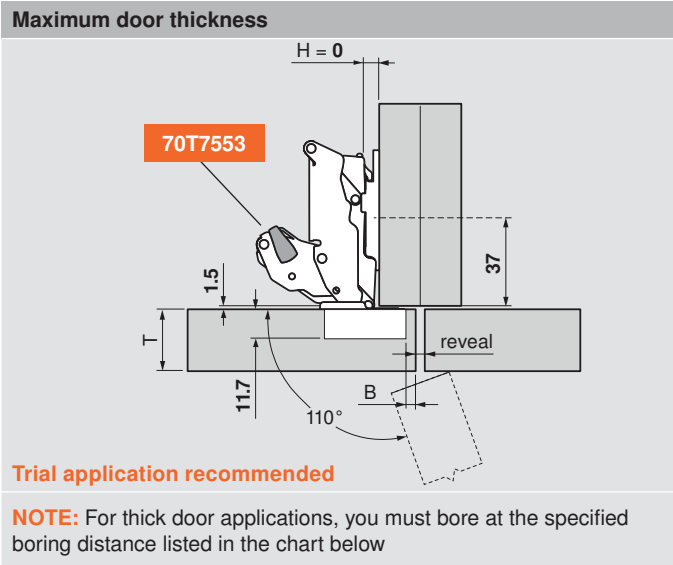
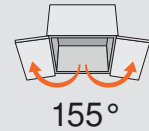

NOTE: Inset application can also be achieved with either a straight-arm hinge with a 18 mm plate or half-cranked hinge with 9 mm plate. Setback of mounting plate would be 38.5 mm + door thickness.

Minimum reveal	T = door thickness						
2	28	27	26	25			
	3	4	5	6	7	*8	
	B = boring distance						

H	Overlay							
0	19	22	24	26	28	30	32	34
	8	11	13	15	17	19	21	23
	B = boring distance							

*Minimum reveal is 1 mm on a 25 mm thick door when bored at 8 mm

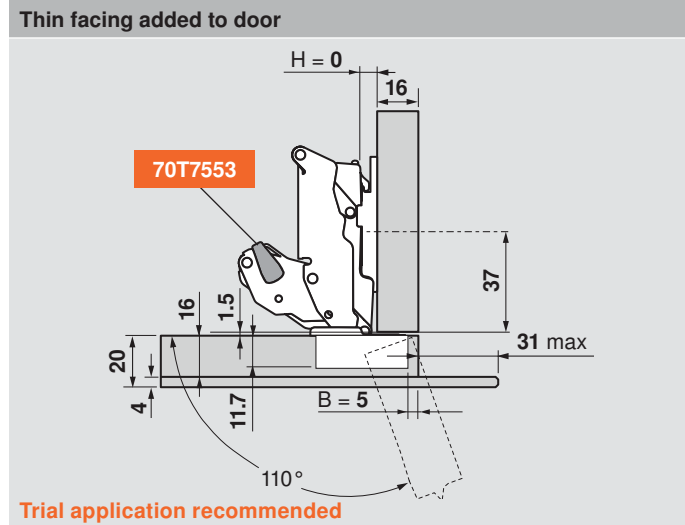
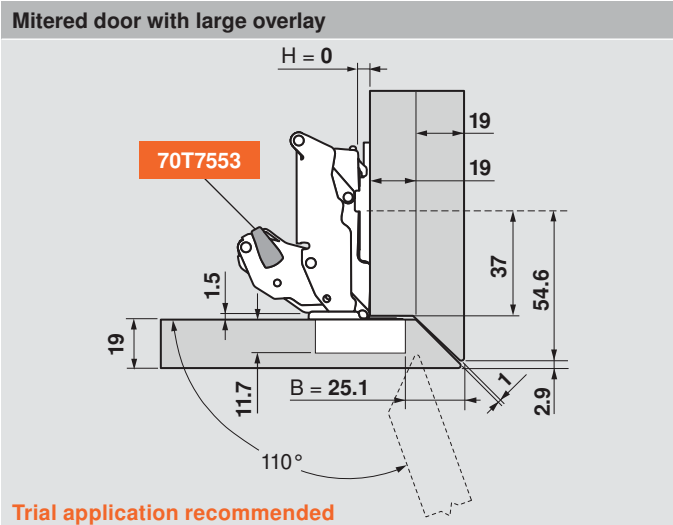

NOTE: Special applications can be achieved in face frame cabinets by blocking out behind the frame or use of the new CLIP wing plates (pages 62-63)

Straight-arm	Soft close
Screw-on	71B7550
Press-in 	71B7580
INSERTA	71B7590

Abbreviations

H	= Plate height
P	= Door protrusion
S	= Side arm protrusion
W	= Side panel width