

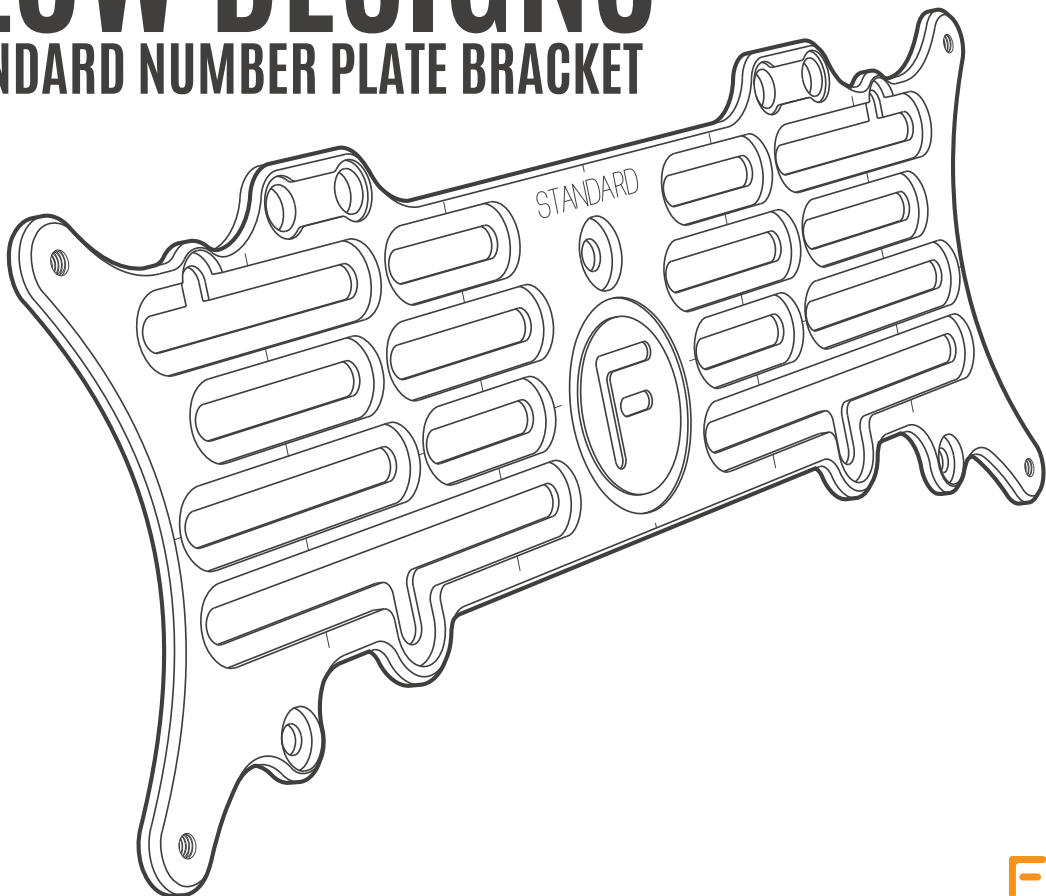

FLOW DESIGNS

STANDARD NUMBER PLATE BRACKET



INSTALLATION DIAGRAM - STEP 1

MOUNTING STANDARD NUMBER PLATE BRACKET TO VEHICLE

INSTALLATION GUIDE

- Remove existing number plate from vehicle.
- Choose Bracket Mounting Option to suit vehicle.
 - Option 1** (M6 Connector Bolts)
 - Option 2** (10g Screws)

For additional mounting options, refer to installation guide on separate page.

- Mercedes Rear** (M5 Bolts)
- Alfa Romeo Rear** (10g Screws)

- Select correct length bolt / screw (**a, b** or **c**) to suit Mounting Option. Use shorter bolts / screws if spacers are not used.

- Insert bolt / screw through number plate bracket and optional spacer then align to vehicle.

- Tighten Mounting bolts / screws to secure number plate bracket to vehicle.

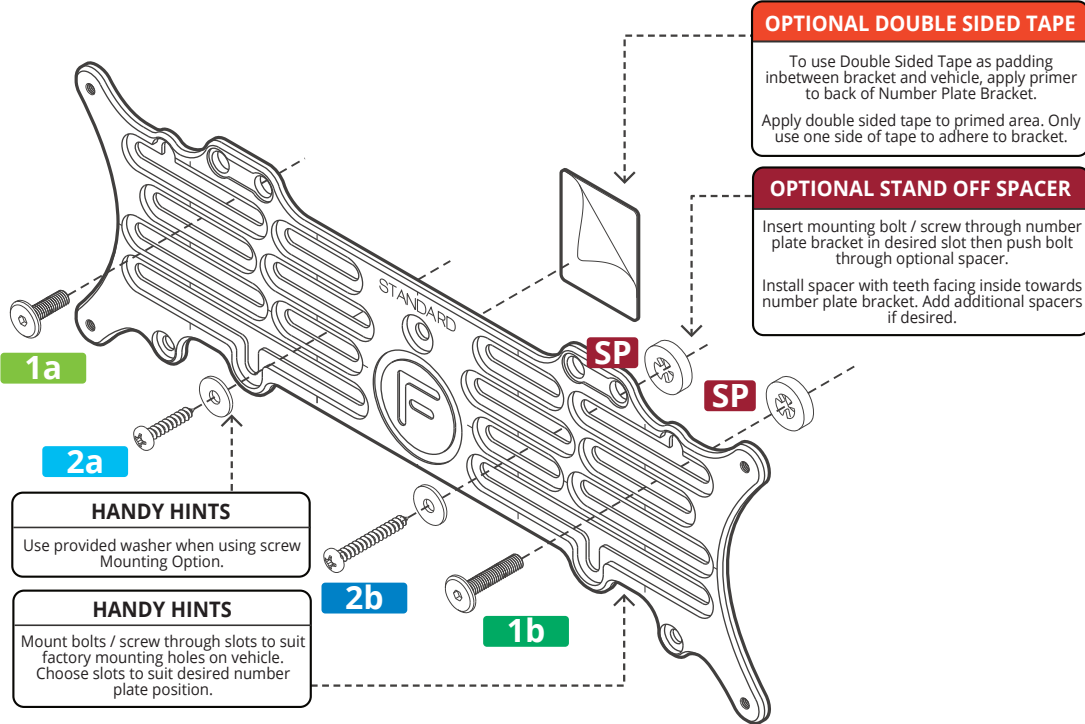

HANDY HINTS

Use provided washer when using screw Mounting Option.

HANDY HINTS

Mount bolts / screw through slots to suit factory mounting holes on vehicle. Choose slots to suit desired number plate position.

BRACKET FITTING KIT

OPTION 1a



CONNECTOR BOLT
BLACK STAINLESS
M6 X 20MM
X 2

OPTION 1b



CONNECTOR BOLT
BLACK STAINLESS
M6 X 30MM
X 2

OPTION 1c



CONNECTOR BOLT
BLACK STAINLESS
M6 X 15MM
X 2

OPTION 2a



10G X 25MM
SELF-TAPPING
SCREW
+
16mm WASHER
X 2

OPTION 2b



10G X 38MM
SELF-TAPPING
SCREW
+
16mm WASHER
X 2

SPACER



STAND OFF
SPACER
X 4

DOUBLE SIDED TAPE

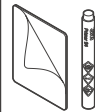

3M DOUBLE
SIDED TAPE
X 4
+
PRIMER
X 1



FLOW DESIGNS

STANDARD NUMBER PLATE BRACKET
ADDITIONAL MOUNTING OPTIONS

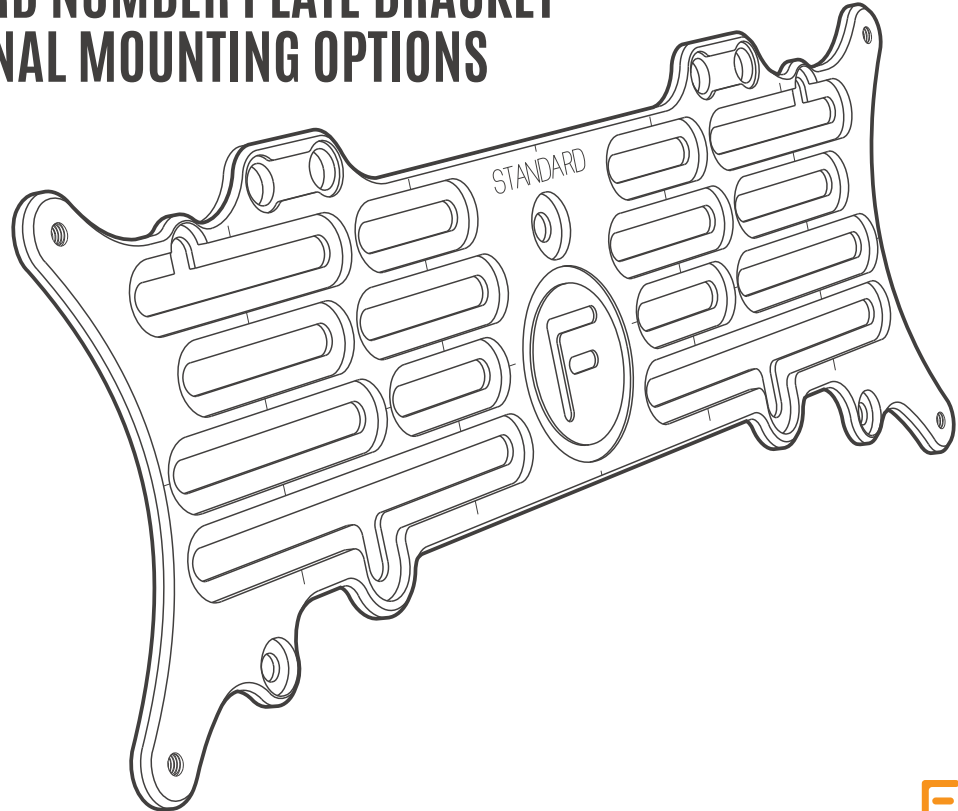

INSTALLATION DIAGRAM - ALFA ROMEO REAR

MOUNTING STANDARD NUMBER PLATE BRACKET TO VEHICLE

INSTALLATION GUIDE

- Remove existing number plate from vehicle.
- Align and thread screws with washers through Standard number plate bracket to OEM rear mounting plate holes.
- Push screw through provided spacer with teeth facing inside towards the number plate bracket.
- Adjust up or down to suit your application.
- Tighten Mounting bolts to secure Standard number plate bracket to vehicle.

ALFA ROMEO FITTING KIT

ALFA ROMEO



10G X 25MM
SELF-TAPPING
SCREW
+
16mm WASHER
X 3

SPACER



STAND OFF
SPACER

X 3

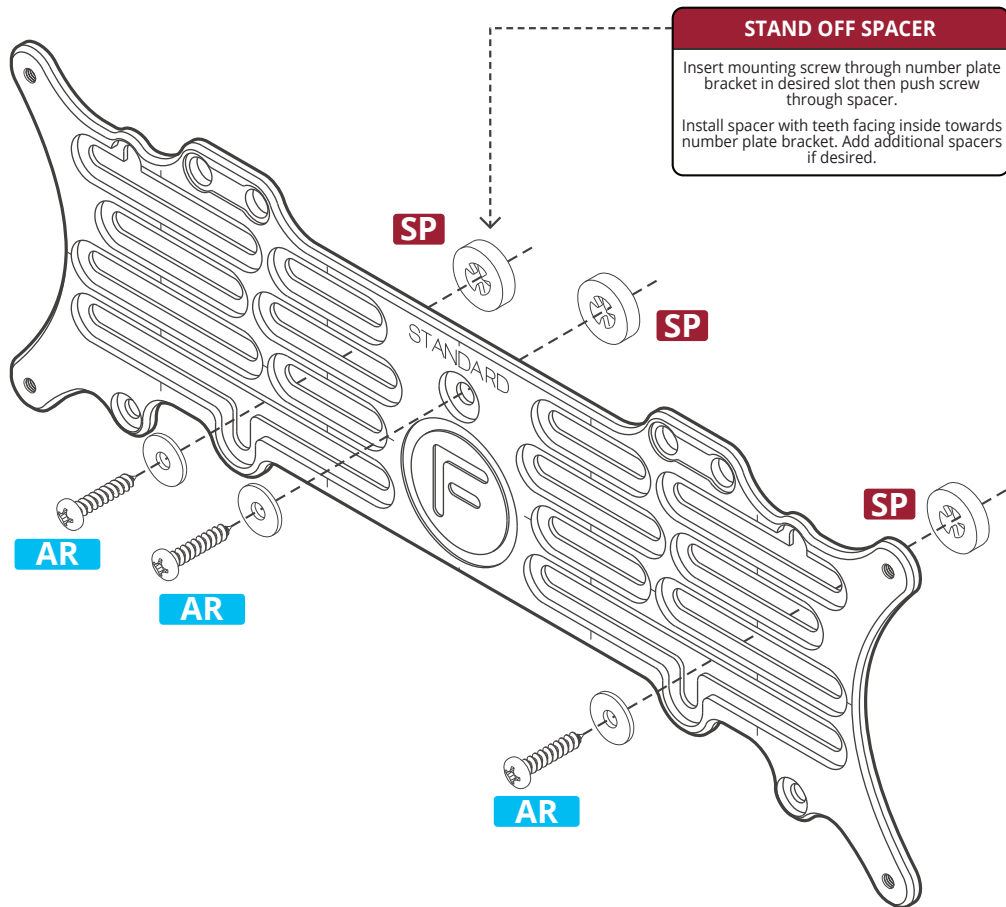

INSTALLATION DIAGRAM - MERCEDES REAR

MOUNTING STANDARD NUMBER PLATE BRACKET TO VEHICLE

INSTALLATION GUIDE

- Remove existing number plate from vehicle.
- Align and insert bolts through Standard Number plate bracket to 4 OEM rear plate mounting holes.
- Tighten Mounting bolts to secure number plate bracket to vehicle.

MERCEDES REAR FITTING KIT

MERCEDES



MERCEDES
BENZ REAR
CONNECTOR BOLT
BLACK STAINLESS
M5 X 20MM
X 4

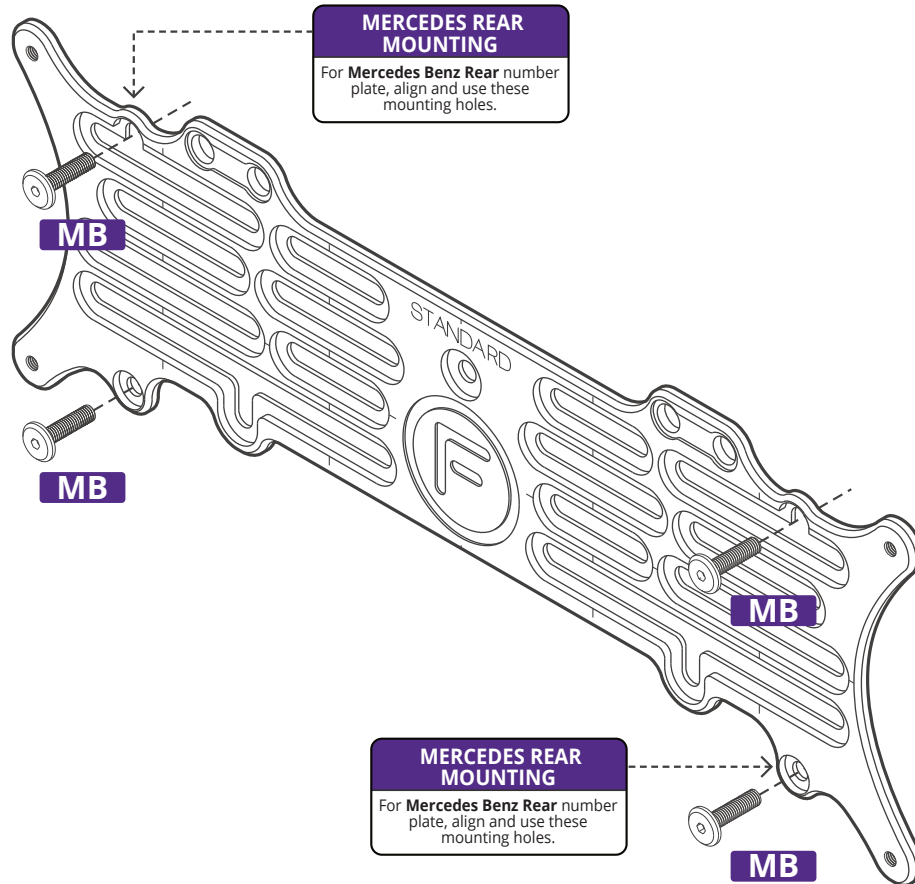

INSTALLATION DIAGRAM - STEP 2

MOUNTING NUMBER PLATE TO STANDARD NUMBER PLATE BRACKET

INSTALLATION GUIDE

- Choose Plate Mounting Option:
 - **Option 1** (6mm Dress Bolt)
 - **Option 2** (6mm Countersunk)
 - **Option 3** (8mm Dress Bolt)
 - **Option 4** (M4 Rubber Nut)
 - **Option 5** (Kingpin Bolt)
- Insert bolt through Standard number plate, then align and mount to number plate bracket.
- Tighten Plate Mounting bolts to secure number plate to bracket.

OPTION 1 & 2

6mm Bolts to be used on Standard Metal number plates.

OPTION 3

8mm Bolts to be used on Standard Polycarbonate/Acrylic number plates.

OPTION 4

If Rubber Nut option is used, Stand off Spacers are required. Insert Rubber Nut into hole before mounting number plate to bracket.

OPTION 5 - KINGPIN COVER

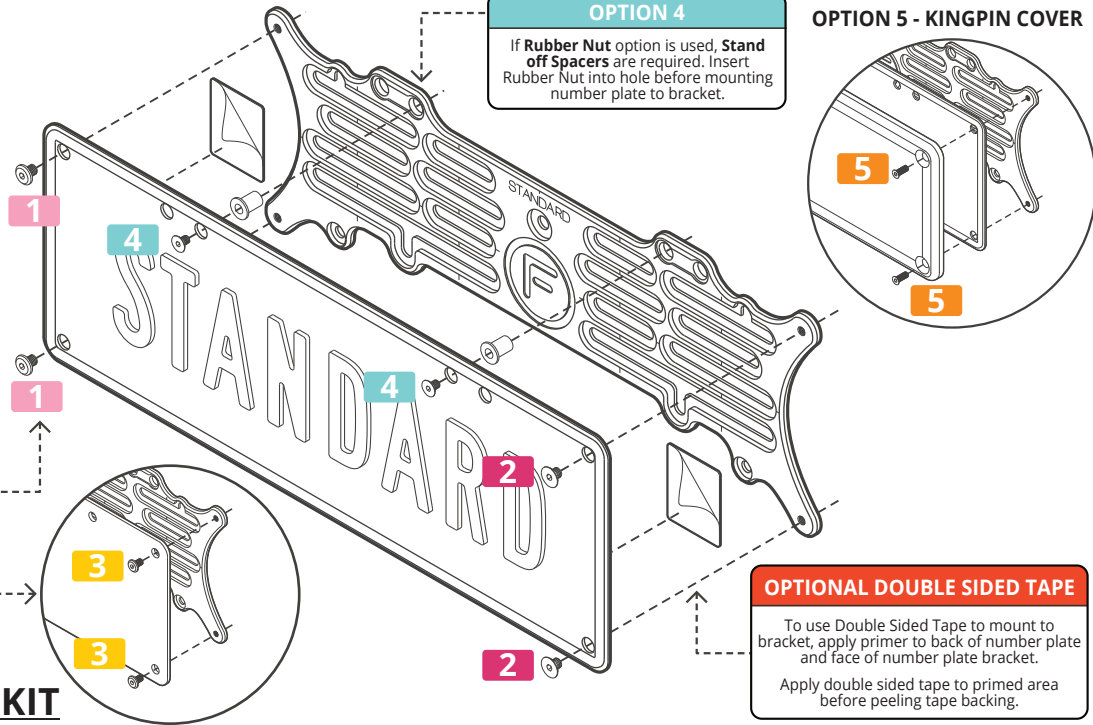

OPTIONAL DOUBLE SIDED TAPE

To use Double Sided Tape to mount to bracket, apply primer to back of number plate and face of number plate bracket.

Apply double sided tape to primed area before peeling tape backing.

NUMBER PLATE FITTING KIT

OPTION 1



DRESS BOLT
BLACK STAINLESS
M5 X 6MM
X 4

OPTION 2



COUNTERSUNK
BLACK STAINLESS
M5 X 6MM
X 4

OPTION 3



POLYCARBONATE /
ACRYLIC PLATE
DRESS BOLT
BLACK STAINLESS
M5 X 8MM
X 4

OPTION 4



M4 RUBBER NUT
+
BLACK STAINLESS
M4 X 12MM
X 2

OPTION 5



KINGPIN
COVER BOLT
COUNTERSUNK
BLACK STAINLESS
M5 X 14MM
X 4

DOUBLE SIDED TAPE



3M DOUBLE
SIDED TAPE
X 4
+
PRIMER
X 1

PARTS AND FITTING KIT

STANDARD NUMBER PLATE BRACKET

PARTS LIST

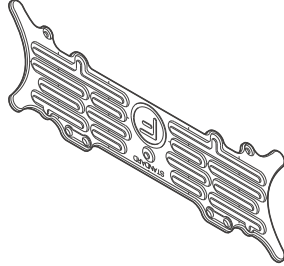

X 1
STANDARD
NUMBER PLATE BRACKET

X 2
CONNECTOR
BOLT
BLACK STAINLESS
M6 X 20MM

X 5
16mm WASHER
SELF-TAPPING
SCREW +
10G X 25MM

X 2
CONNECTOR
BOLT
BLACK STAINLESS
M6 X 30MM

X 2
16mm WASHER
SELF-TAPPING
SCREW +
10G X 38MM

X 2
CONNECTOR
BOLT
BLACK STAINLESS
M6 X 15MM

X 1
4MM
ALLEN KEY



X 1
3MM
ALLEN KEY



X 4
DRESS BOLT
BLACK STAINLESS
M5 X 6MM

X 4
KINGPIN
COVER BOLT
BLACK STAINLESS
M5 X 14MM



X 4
COUNTERSUNK
BLACK STAINLESS
M5 X 6MM

X 4
CONNECTOR BOLT
BLACK STAINLESS
M5 X 20MM



X 7
STAND OFF
SPACER



X 4
POLYCARBONATE /
ACRYLIC PLATE
DRESS BOLT
BLACK STAINLESS
M5 X 8MM



X 2
M4 RUBBER NUT
BLACK STAINLESS
M4 X 12MM

X 4
DOUBLE SIDED
3M VHB
TAPE



X 1
3M
PRIMER

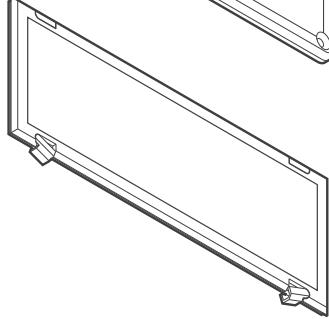

**ALREX NUMBER
PLATE COVER**

Alrex number plate covers to suit
Standard size number plate.

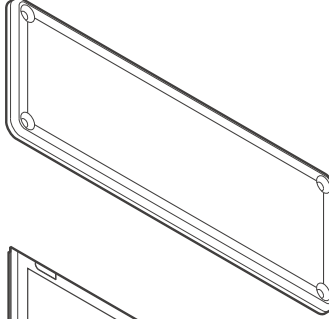

**KINGPIN NUMBER
PLATE COVER**

Kingpin number plate covers to
suit Standard size number plate.

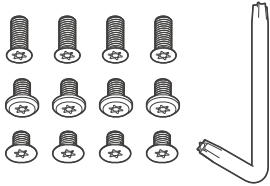

**SECURITY BOLT
PACK OPTION**

Security Bolts with Security Key to
mount number plate to bracket.

OPTIONAL ACCESSORIES (SOLD SEPARATELY)