

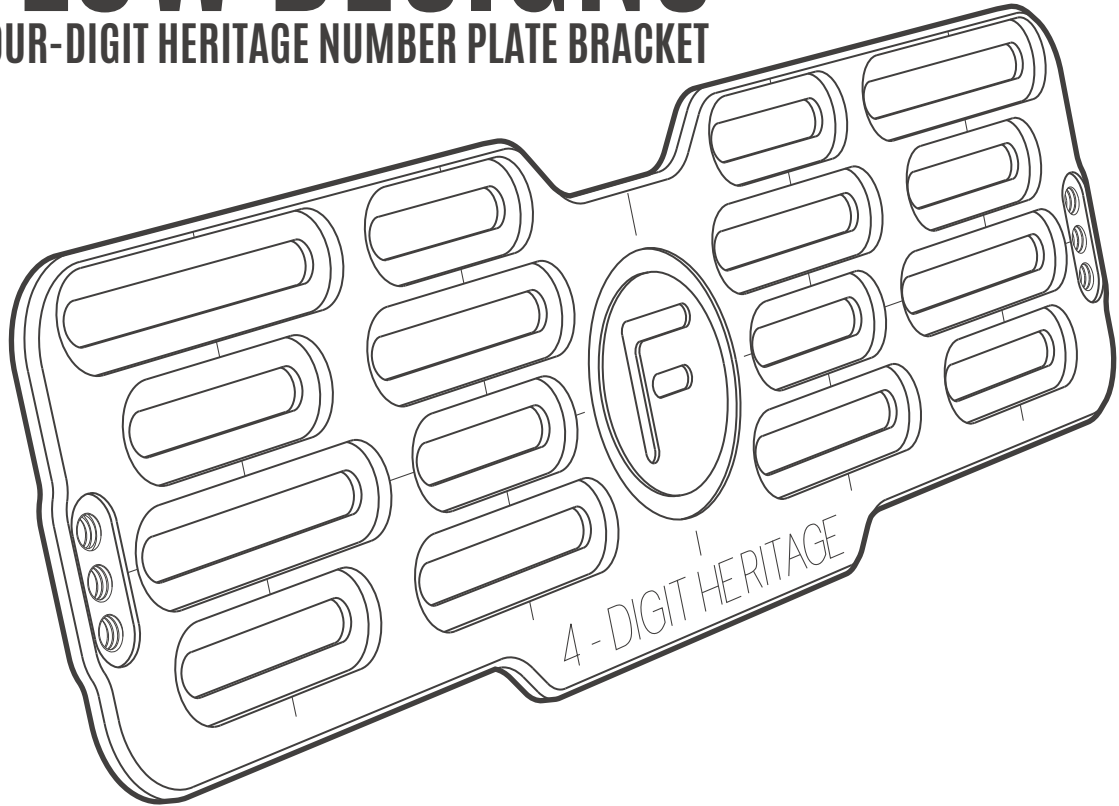

FLOW DESIGNS

FOUR-DIGIT HERITAGE NUMBER PLATE BRACKET



INSTALLATION DIAGRAM - STEP 1

MOUNTING FOUR-DIGIT HERITAGE NUMBER PLATE BRACKET TO VEHICLE

INSTALLATION GUIDE

- Remove existing number plate from vehicle.
- Choose Mounting **Option 1** (M6 Connector Bolts) or Mounting **Option 2** (10g Screws) to suit vehicle.
- Select correct length bolt / screw (**a** or **b**) to suit Mounting Option. Use shorter bolts / screws if spacers are not used.
- Insert bolt / screw through number plate bracket and optional spacer then align to vehicle.
- Tighten Mounting bolts / screws to secure number plate bracket to vehicle.

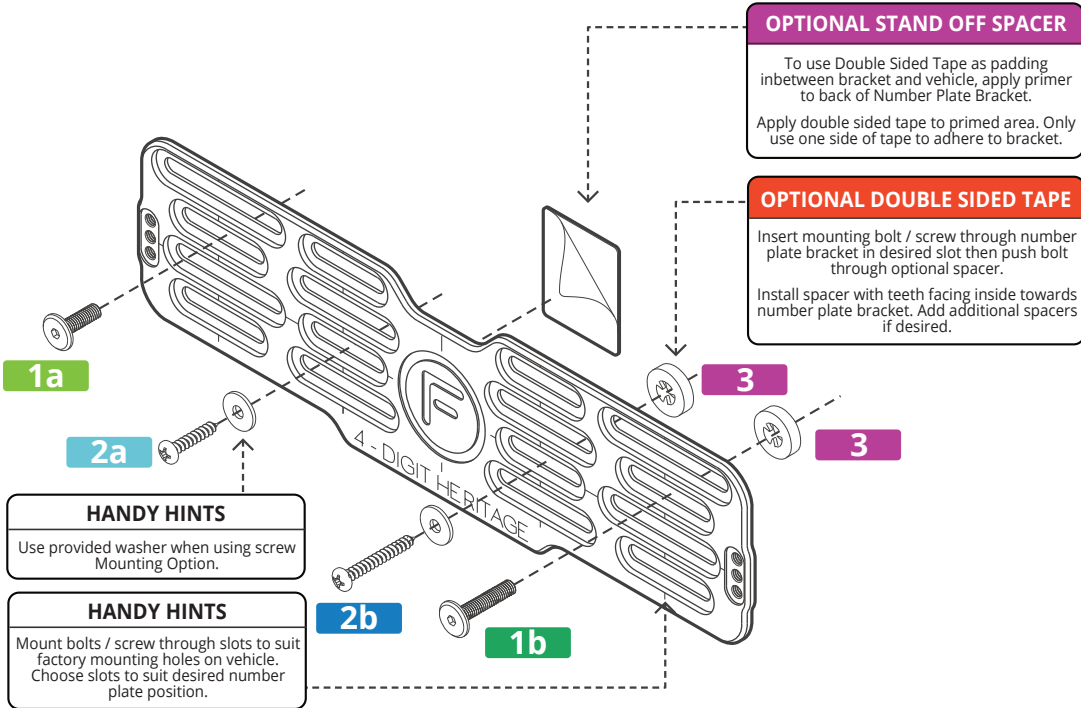

OPTIONAL STAND OFF SPACER

To use Double Sided Tape as padding inbetween bracket and vehicle, apply primer to back of Number Plate Bracket.

Apply double sided tape to primed area. Only use one side of tape to adhere to bracket.

OPTIONAL DOUBLE SIDED TAPE

Insert mounting bolt / screw through number plate bracket in desired slot then push bolt through optional spacer.

Install spacer with teeth facing inside towards number plate bracket. Add additional spacers if desired.

HANDY HINTS

Use provided washer when using screw Mounting Option.

HANDY HINTS

Mount bolts / screw through slots to suit factory mounting holes on vehicle. Choose slots to suit desired number plate position.

BRACKET FITTING KIT

OPTION 1a

CONNECTOR BOLT
BLACK STAINLESS
M6 X 20MM
X 2

OPTION 1b

CONNECTOR BOLT
BLACK STAINLESS
M6 X 30MM
X 2

OPTION 2a

10G X 25MM
SELF-TAPPING
SCREW
+
16mm WASHER
X 2

OPTION 2b

10G X 38MM
SELF-TAPPING
SCREW
+
16mm WASHER
X 2

3

STAND OFF
SPACER
X 4

DOUBLE SIDED TAPE

3M DOUBLE
SIDED TAPE
X 4
+
PRIMER
X 1

INSTALLATION DIAGRAM - STEP 2

MOUNTING NUMBER PLATE TO FOUR-DIGIT HERITAGE NUMBER PLATE BRACKET

INSTALLATION GUIDE

- Choose Plate Mounting **Option 1** (Dress Bolts) or **Option 2** (Security Bolts).
- Insert bolt through Heritage number plate, then align and mount to number plate bracket.
- Tighten Plate Mounting bolts to secure number plate to bracket.

OPTION 1

Choose Dress Bolt option to cover brass eyelet.

1



HANDY HINTS

Align Heritage number plate to desired height then mount through one of the holes.

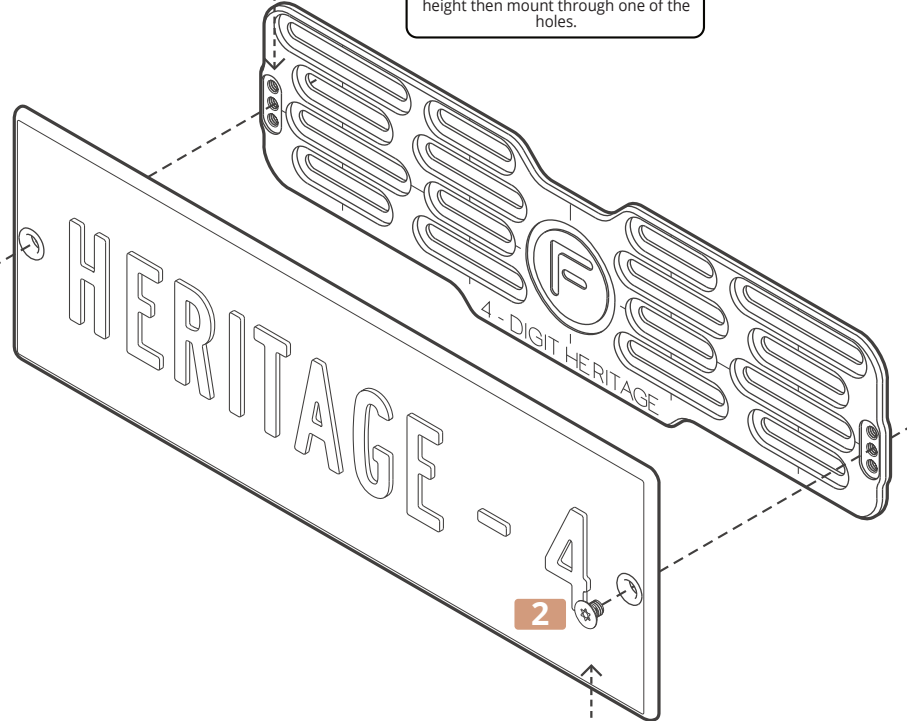

2

OPTION 2

Choose Security Bolt option to expose brass eyelet. Use provided Security Key to tighten.

NUMBER PLATE FITTING KIT

OPTION 1



DRESS BOLT
BLACK STAINLESS
M6 X 8MM

X 2

OPTION 2



SECURITY BOLT
BLACK STAINLESS
M6 X 10MM

X 2

PARTS AND FITTING KIT

FOUR-DIGIT HERITAGE NUMBER PLATE BRACKET

PARTS LIST

X 1
FOUR-DIGIT HERITAGE
NUMBER PLATE BRACKET

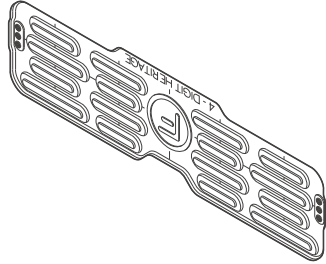

X 2
CONNECTOR
BOLT
BLACK STAINLESS
M6 X 20MM



X 2
10G X 25MM
SELF-TAPPING
SCREW
+
16mm WASHER



X 2
DRESS BOLT
BLACK STAINLESS
M6 X 8MM



X 4
SPACER
STAND OFF



X 4
3M VHB
DOUBLE SIDED
TAPE

X 2
CONNECTOR
BOLT
BLACK STAINLESS
M6 X 30MM



X 2
10G X 38MM
SELF-TAPPING
SCREW
+
16mm WASHER



X 2
SECURITY BOLT
BLACK STAINLESS
M6 X 10MM



X 1
3M
PRIMER



X 1
M6
SECURITY
KEY



X 1
4MM
ALLEN KEY

OPTIONAL ACCESSORIES (SOLD SEPARATELY)

MERCEDES REAR ADAPTER PLATE

Rear Adapter Plate required to
for use with Mercedes Benz
vehicles.

