

TC SoapWorks®

Manual Counter-Mounted Liquid Soap System



technical concepts

Innovative Hygiene Solutions

Never Drips, Never Clogs, Always Works

With SoapWorks® you'll never have to fix or replace another soap dispenser!

System Benefits:

- Always works—no more clogs and drips means no messy clean-up
- Reduces labor to change cartridges, with up to 2000 hand washes per refill
- Disposable soap refills with easy "quick-twist" loading
- Dispenser fits existing counter opening for easy installation
- ADA compliant in use

System Specifications:

- Capacity: 800 ml / 27oz. or 1600 ml / 57oz. refills deliver 1000 or 2000 hand washes per refill
- Chrome or Chrome & Black spout cover options
- Mount through 1" (25mm) diameter hole in lavatory or countertop
- Maximum counter thickness 2" (50.8mm)

Note: Use of unauthorized refills or vandalism voids warranty.



SoapWorks® Manual Dispensers:

Stock#	Description
401544 Polished Chrome
401531 Chrome/Black (Shown)

Case Pack: 12, Case Weight: 7.5 lbs., Case Cube: .79 ft³



SoapWorks® Refills:

800 ml	1600 ml	Description
401313.....	401543.....	Pure & Natural® Lotion Hand Soap
402363.....	402364.....	Free 'n Clean Lotion Hand Soap
401311.....	401541.....	Lotion Hand Soap w/Moisturizers
401312.....	401542.....	Antimicrobial Hand Soap

800 ml Case Pack: 4, Case Weight: 9 lbs., Case Cube: .33 ft³

1600 ml Case Pack: 4, Case Weight: 18 lbs., Case Cube: .50 ft³

SoapWorks® Specifications

SoapWorks System Features:

- Refill Delivery Tube
- Never Drips
- Never Clogs
- Always Works!

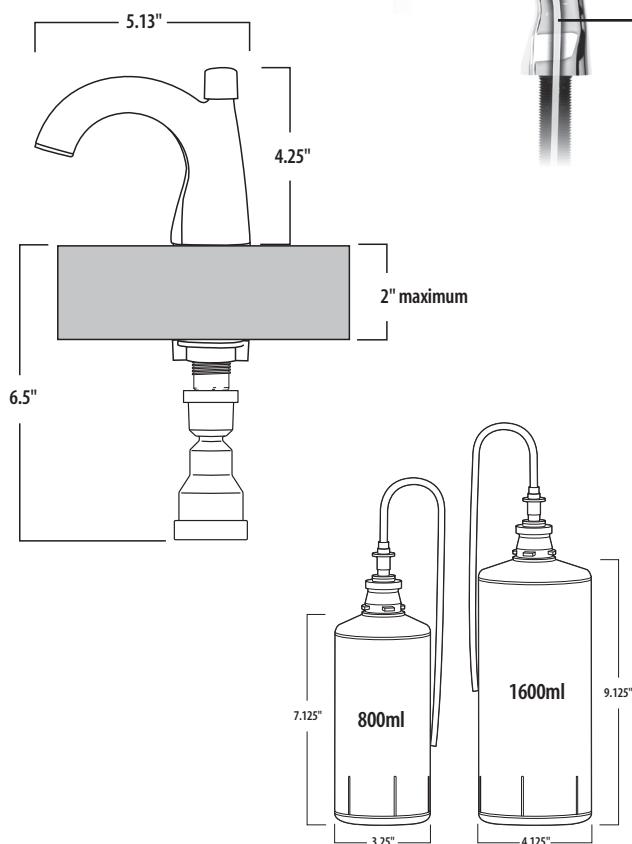

SoapWorks® Counter-Mounted Soap System Quick Installation Instructions

1. Mount SoapWorks® dispenser in counter top.
2. Insure all components and wires are installed/connected properly.
3. Before installing refill, insure the tube on the refill bottle is fully inserted into the actuator/pump assembly.
4. Next, unlock pump on refill by twisting counter-clockwise. Actuator will pop up.
5. Guide refill tube up through bottom of motor assembly and up the spout.
6. Lock soap refill into place by turning clockwise a 1/4 turn.

Compliance:

- Meets A.D.A. requirements
- Pure & Natural® refills are Green Seal Certified

Warranty:

- Lifetime warranty against defects in parts and workmanship



ADA COMPLIANT



technical concepts
Innovative Hygiene Solutions

technicalconcepts.com

World Headquarters:
Serving North and South America

Technical Concepts LLC
1301 Allanson Road
Mundelein, Illinois 60060 U.S.A.
Toll Free: 1-800-551-5155
Fax: 1-800-551-5046

C&L Supply Company
Smarter Industrial Solutions
Est. 1981
www.CandLsupply.com

4840 York Blvd
Los Angeles CA 90042
P: 323-258-1940
F: 323-258-6523
sales@CandLsupply.com

