



High Efficiency Quarter Stall Washout Urinal Flush Valve System

Model MF101814U05

Description

Complete HEU System with Exposed Manual Urinal Flushometer and Vitreous China Fixture.

Flush Cycle

Model MF101814U05 (0.5 gpf/1.9 Lpf)

Specifications

Flushometer Specification (Model MF-700-U05)

- Chrome Plated, Exposed, Diaphragm Type Urinal Flushometer for Use with Right or Left Side Water Supply
- Quiet Operation
- Uses Proprietary Silicone Diaphragm with Filtered Bypass
- ADA Compliant Non-Hold Open Sealed Brass Handle
- 3/4" I.P.S. Angle Stop
- Adjustable Tailpiece
- High Back Pressure Vacuum Breaker with Single Piece Hex Coupling Nut
- Spud Coupling and Flange for 3/4" Top Spud
- Sweat Solder Kit and Wall Flange with Set Screw
- No External Water Volume Adjustment
- High Efficiency for Water Conservation

Compliance & Certifications

- ASSE 1037-2015
- ASME A112.1035-2015
- CSA B125.37-15
- WaterSense® Listed



For Finish Variations Please Consult Factory

Fixture Specification (Model AUU-1018-14)

- Complies with ADA Accessible Standards
- White Color
- Wall Hung Vitreous China
- Washout Flushing Action
- Elongated Rim
- Integral Flushing Rim
- Integral Trap
- 3/4" (19mm) I.P.S. Top Spud Inlet (Included)
- 2" (50mm) NPT Outlet Flange (Included)
- 100% Factory Tested
- Hanging Bracket (1 included)

Compliance & Certifications

- ASME A112.19.2/CSA B45.1
- ADA- With installation consideration for "Section 605, Urinals" of the ADA 2010 Standard.
- ICC/ANSI A117.1
- ICC-ES PMG® Certified
- WaterSense® Listed



Plumbing System Requirements

- Minimum Flowing Pressure: 25 PSI
- Maximum Static Pressure: 80 PSI
- Minimum Flow Rate: 18 GPM

Disclaimer

Note: All vitreous china dimensions shown in these drawings are nominal and not to scale. Dimensions can vary within the tolerances established in the governing ASME A112.19.2/CSA B45.1 standard. It is important to consider this when planning rough-in and plumbing layouts.

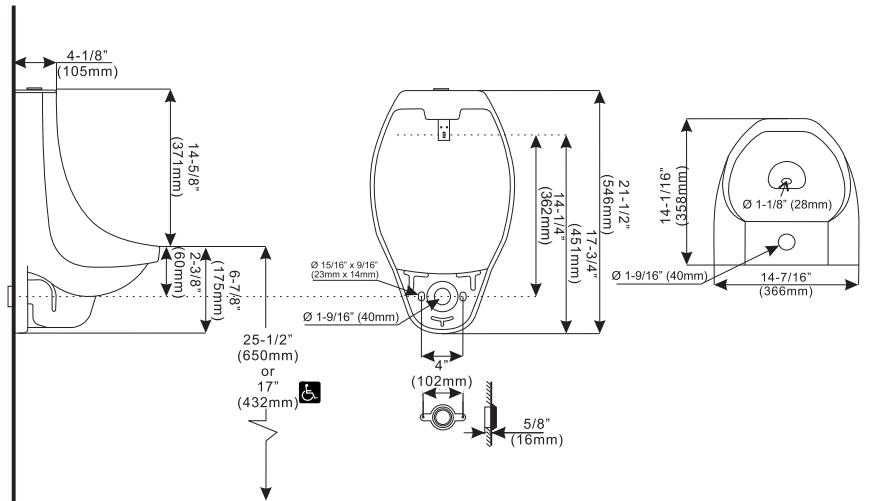
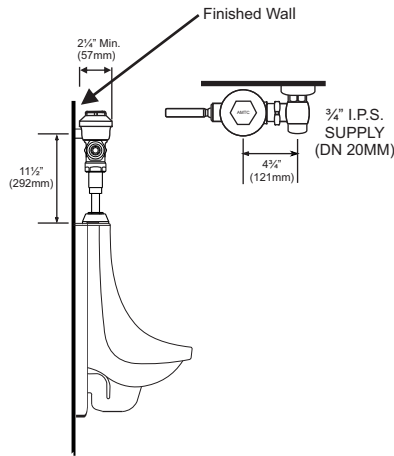

Warranty
5 Years

This space for Architect/Engineer Approval

The information contained in this document is subject to change without notice.

Advanced Modern Technologies Corporation • 19800 Nordhoff Place • Chatsworth, CA 91311
Tel: (818) 883-2682 • Toll Free: (800) 874-7822 • Fax: (818) 883-2620 • www.amtccorporation.com