



Floor Mount Dual-Flush High Efficiency Flush Valve System

Model MF1012T16DF

Description

Complete HET System with Exposed Dual-Flush Manual Water Closet Flushometer and Vitreous China Fixture.

Flush Cycle

☐ Model MF1012T16DF (1.6 gpf/6.0 Lpf and 1.1 gpf/4.2 Lpf)

Specifications

Flushometer Specification (Model MF-700-DFT16)

- Dual-Flush Chrome Plated, Exposed, Diaphragm Type Water Closet Flushometer for Use with Right or Left Side Water Supply
- **Green Solution - Reduces Water Usage Per Flush When Pushed DOWN**
- Lift Handle **UP** for Solid Waste and Push **DOWN** for Liquid Waste
- **Reduces Water Usage by Up to 30% when Pushed DOWNWARDS**
- **No Behavioral Change Required By Users To Start Saving Water**
- Quiet Operation
- Uses Proprietary Silicone Diaphragm with Filtered Bypass
- ADA Compliant Non-Hold Open Sealed Brass Handle
- 1" I.P.S. Angle Stop
- Adjustable Tailpiece
- High Back Pressure Vacuum Breaker with Single Piece Hex Coupling Nut
- Spud Coupling and Flange for 1 1/2" Top Spud
- Sweat Solder Kit and Wall Flange with Set Screw
- No External Water Volume Adjustment
- High Efficiency for Water Conservation

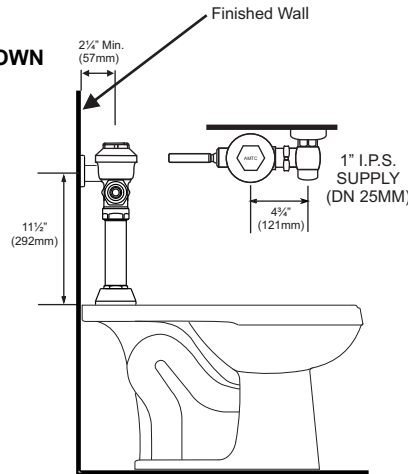

Compliance & Certifications

- ASSE 1037-2015 Listed By IAPMO
- ASME A112.1035-2015
- CSA B125.37-15



For Finish Variations Please Consult Factory

Fixture Specification (Model AUT-1012)

- White Color
- Vitreous China
- Floor Mount Water Closet Bowl
- Elongated Rim
- 10" (254mm) Rough-In
- 1-1/2" (38mm) I.P.S. Top Spud Inlet
- 2" (50mm) Fully Glazed Trapway
- 11" (279mm) x 13" (330mm) Water Surface Area
- Direct Feed Jet
- 100% Factory Tested
- Toilet Seat Not Included

Compliance & Certifications

- ASME A112.19.2/CSA B45.1
- Energy Act of 1992
- ICC-ES PMG® Certified



Plumbing System Requirements

- Minimum Flowing Pressure: 25 PSI
- Maximum Static Pressure: 80 PSI
- Minimum Flow Rate: 25 GPM

Disclaimer

Note: All vitreous china dimensions shown in these drawings are nominal and not to scale. Dimensions can vary within the tolerances established in the governing ASME A112.19.2/CSA B45.1 standard. It is important to consider this when planning rough-in and plumbing layouts.

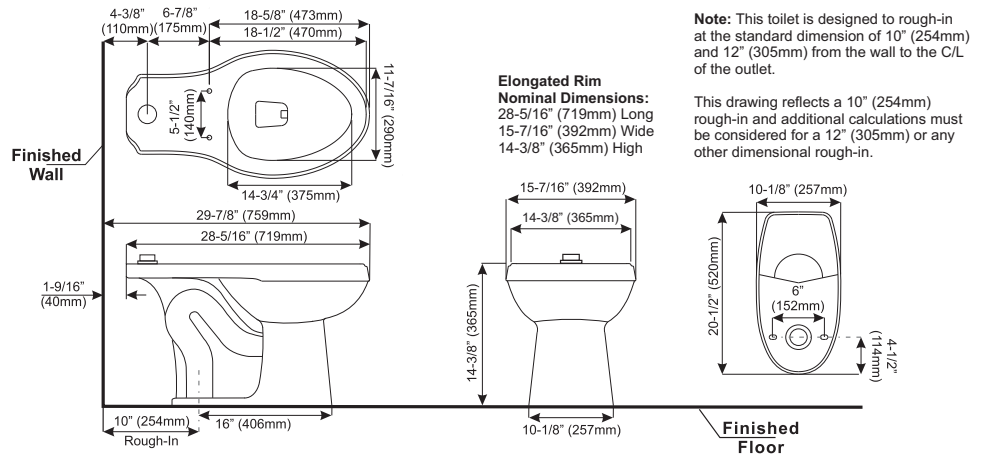

Note: This toilet is designed to rough-in at the standard dimension of 10" (254mm) and 12" (305mm) from the wall to the C/L of the outlet.

This drawing reflects a 10" (254mm) rough-in and additional calculations must be considered for a 12" (305mm) or any other dimensional rough-in.



Warranty

5 Years

This space for Architect/Engineer Approval

The information contained in this document is subject to change without notice.

Advanced Modern Technologies Corporation • 19800 Nordhoff Place • Chatsworth, CA 91311
Tel: (818) 883-2682 • Toll Free: (800) 874-7822 • Fax: (818) 883-2620 • www.amtccorporation.com