

# AMTC HALF-FLUSH® Handle Installation Guide

(Refer to illustrations below)

**NOTE:** Water does not need to be shut off to install HALF-FLUSH® Handle, but use caution to NOT ACTIVATE the valve.

**IMPORTANT:** Make sure that existing diaphragm assembly matches the required flush volume for the existing fixture to assure proper and maximum performance.

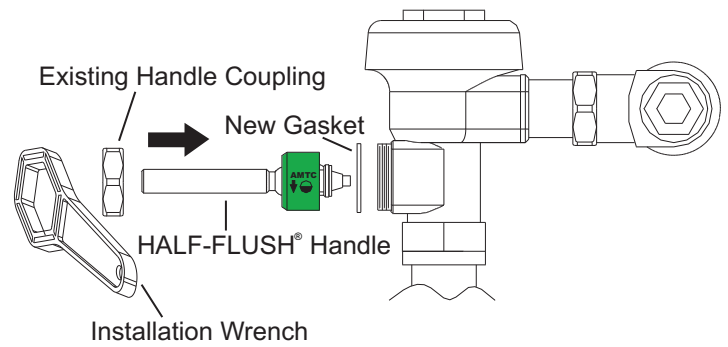
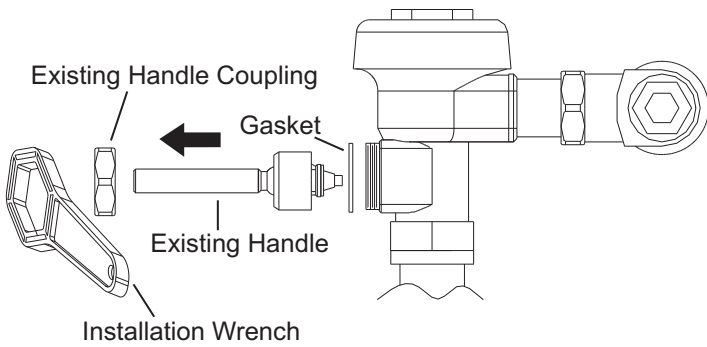

**1** Remove Existing Handle Coupling, Existing Handle, and Gasket from Flushometer Valve Body using supplied Installation Wrench.

**2** Replace with HALF-FLUSH® Handle and New Gasket using Existing Handle Coupling.

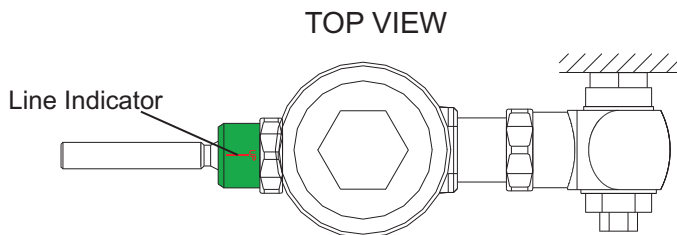

**3** Install HALF-FLUSH® Handle with "RED LINE" Indicator Facing "UP".

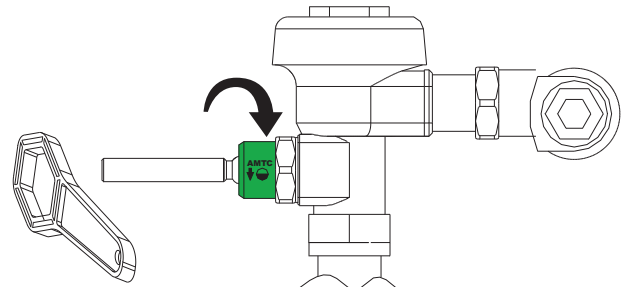

**4** Tighten the Handle Coupling Securely using the supplied Installation Wrench.



4840 York Blvd | Los Angeles CA 90042  
Toll Free: (800) 458-2377 | Fax: (323) 258-6523  
[www.CandLsupply.com](http://www.CandLsupply.com) | [sales@CandLsupply.com](mailto:sales@CandLsupply.com)

Advanced Modern Technologies Corporation • 19800 Nordhoff Place • Chatsworth, CA 91311  
Tel: (818) 883-2682 • Toll Free: (800) 874-7822 • Fax: (818) 883-2620 • [www.amtccorporation.com](http://www.amtccorporation.com)