



# HYBRIDFLUSH<sup>®</sup> AUTOMATIC ADA Wall Hung High Efficiency Flush Valve System

Model  
HSM1012WT11

## Description

Battery Powered, Sensor Operated HYBRIDFLUSH<sup>®</sup> Side Mount Complete HET System with Exposed Automatic Water Closet Flushometer and ADA Vitreous China Fixture.

## Flush Cycle

Model HSM1012WT11 (1.1 gpf/4.2 Lpf)

## Specifications

### Flushometer Specification (Model HSM-801-CT-11)

- Patented Gear Motor Drive
- Hands Free Infrared Sensor Activation
- Vandal and Water Resistant Design
- Chrome Plated Metal Housing
- Quiet Operation
- Electronic Manual Flush Button (Front)
- True Mechanical Manual Flush Button (Side)
- \*Mechanical Button Works When Batteries are Drained
- Operates on (4) "C" Alkaline Batteries (Included)
- Battery Life - 3+ Years
- "Low Battery" Blinking LED Indicator
- Easy Battery Replacement-No Water Shut Off Necessary
- Adjustable Sensor Distance
- Optional Three (3) Second Flush Delay Mode
- Optional 24-Hour Flush Mode
- Uses Proprietary Silicone Diaphragm with Filtered Bypass
- 1" I.P.S. Angle Stop
- Adjustable Tailpiece
- High Back Pressure Vacuum Breaker with Single Piece Hex Coupling Nut
- Spud Coupling and Flange for 1 1/2" Top Spud
- Sweat Solder Kit and Wall Flange with Set Screw
- High Efficiency For Water Conservation

### Compliance & Certifications

- ASSE 1037-2015
- ASME A112.1035-2015
- CSA B125.37-15



For Finish Variations Please Consult Factory

### Fixture Specification (Model AUT-1012W)

- Complies with ADA Accessible Standards
- White Color
- Vitreous China
- Wall Hung Water Closet Bowl
- Elongated Rim
- 10" (254mm) Rough-In
- 1-1/2" (38mm) I.P.S. Top Spud Inlet
- 2" (50mm) Fully Glazed Trapway
- 7-1/2" (190mm) x 8-1/2" (216mm) Water Surface Area
- Direct Feed Jet
- 100% Factory Tested
- Toilet Seat Not Included

### Compliance & Certifications

- ASME A112.19.2/CSA B45.1
- Energy Act of 1992
- ADA- With installation consideration for section 604 Water Closets, Accessibility Guidelines.
- ICC/ANSI A117.1
- TAS - With installation consideration for section: 4.16.3. Adult seat height 17" (432mm) to 19" (483mm).
- CSA B651 - With installation consideration for Clause 4.3.6 of the standard.
- ICC-ES PMG<sup>®</sup> Certified
- WaterSense<sup>®</sup> Listed



### Plumbing System Requirements

- Minimum Flowing Pressure: 25 PSI
- Maximum Static Pressure: 80 PSI
- Minimum Flow Rate: 25 GPM



## The HYBRIDFLUSH<sup>®</sup> Advantage

The HYBRIDFLUSH<sup>®</sup> is a revolutionary full-featured automatic/manual flush valve system. The HYBRIDFLUSH<sup>®</sup> incorporates a unique patented mechanism that allows for automatic/manual operation for unsurpassed reliability. The patented HYBRIDFLUSH<sup>®</sup> design allows for a push button to be used as an alternate flush option that is independent of the battery power. The HYBRIDFLUSH<sup>®</sup> by Advanced Modern Technologies Corporation is the most efficient, economical, and complete automatic flush valve system on the market.



Warranty  
5 Years



ADA Compliant

## Architect/Engineer Approval

Job Name	_____
Date	_____
Model Specified	_____
Quantity	_____
Variations Specified	_____
Customer/Wholesaler	_____
Contractor	_____
Architect	_____



# HYBRIDFLUSH<sup>®</sup> AUTOMATIC

ADA Wall Hung High Efficiency Flush Valve System

Model  
HSM1012WT11

## Specifications

<b>Operation:</b>	<b>Hybrid (Automatic/Manual)</b>
<b>Outer Casing:</b>	<b>Standard-Chrome Metal</b>
<b>Operating Water Pressure:</b>	<b>15 PSI - 100 PSI</b>
<b>Sensor Type:</b>	<b>Infrared</b>
<b>Battery Type:</b>	<b>Four "C" Alkaline Batteries</b>
<b>Battery Life:</b>	<b>3+ Years</b>
<b>Arming Delay:</b>	<b>5 Seconds</b>
<b>Sensing Range:</b>	<b>Adjustable, Default Set to 24" (610mm)</b>
<b>Operation Mode:</b>	<b>Can be Turned On and Off</b>
<b>Water Saver Mode:</b>	<b>N/A</b>
<b>Flush Delay Mode:</b>	<b>3 Seconds Delay Before Activating Flush</b>
<b>24 Hour Flush Mode:</b>	<b>Once Every 24 Hours After Last User</b>
<b>Flush Cycle:</b>	<b>Specified by Model</b>
<b>Model HSM1012WT11</b>	<b>1.1 gpf/4.2 Lpf</b>
<b>Manual Override:</b>	<b>Electronic Button/True Mechanical Button</b>

## Visual Indicator Guide

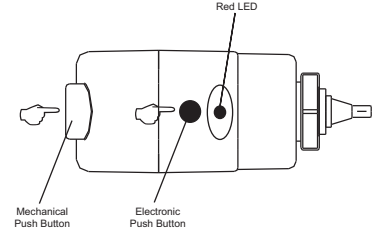

- Red LED** - Constant blinking red LED indicates batteries are low and need replacing.
- Electronic Push Button** - Allows manual activation of flush when needed.
- Mechanical Push Button** - Allows manual activation of flush when needed and when batteries are drained.

## Dimensions

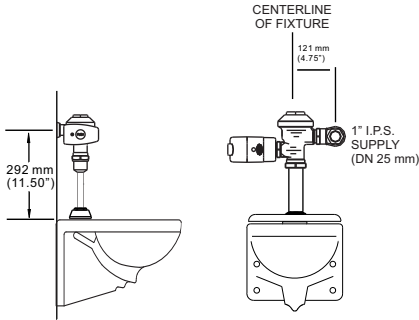

## Application

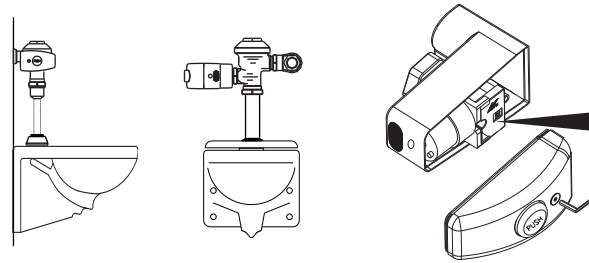

**Mode Adjustment Guide**

**Switch 1 : Water Saver**  
 OFF - Flushes after every user  
 ON - Not Applicable For Water Closets (Toilets)

**Switch 2 : 24 Hour Flush**  
 OFF - None  
 ON - Flushes once every 24 hours after last user

**Switch 3 : Flush Delay**  
 OFF - 3 seconds delay before activating a flush  
 ON - No delay

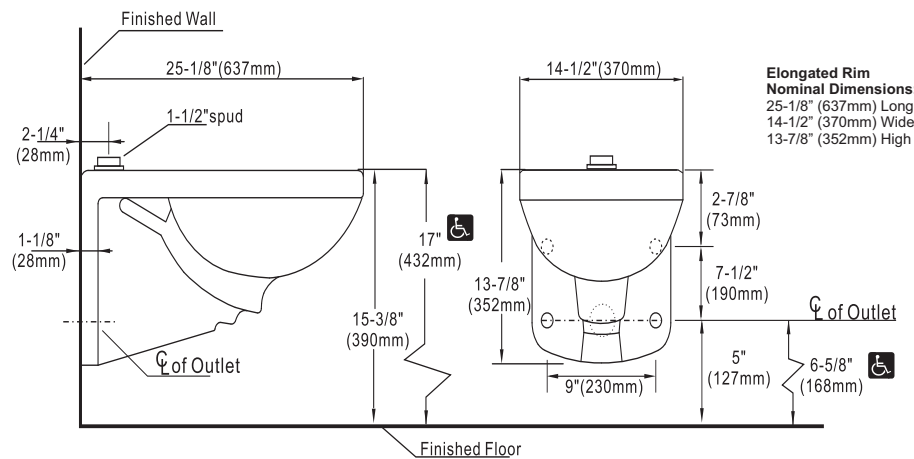
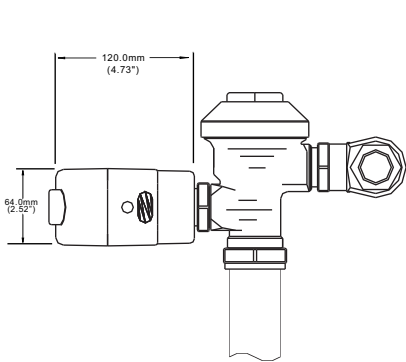

**Elongated Rim Nominal Dimensions:**  
 25-1/8" (637mm) Long  
 14-1/2" (370mm) Wide  
 13-7/8" (352mm) High

## Disclaimer

Note: All vitreous china dimensions shown in these drawings are nominal and not to scale. Dimensions can vary within the tolerances established in the governing ASME A112.19.2/CSA B45.1 standard. It is important to consider this when planning rough-in and plumbing layouts.

Advanced Modern Technologies Corporation • 19800 Nordhoff Place • Chatsworth, CA 91311  
 Tel: (818) 883-2682 • Toll Free: (800) 874-7822 • Fax: (818) 883-2620 • [www.amtccorporation.com](http://www.amtccorporation.com)