



# HYBRIDFLO<sup>®</sup>

AUTOMATIC FAUCET SYSTEMS

Model  
AEF-305T

## Description

Sensor Operated, Gear Motor Driven, Chrome Plated Brass Wall Mounted Faucet System For Tempered or Hot/Cold Water Operation

## Flow Rate

- 0.35 gpm/1.3 Lpm Spray Head (Cal Green Compliant)
- 0.5 gpm/1.9 Lpm Spray Head



## Specifications

- Chrome Plated Solid Brass Wall Mounted Spout (Standard)
- Less Than 0.25% Lead Content by Weighted Average
- Patented BRV<sup>®</sup> and Gear Motor Drive
- Hands Free Infrared Sensor Activation
- Powered by Four (4) C-Cell Batteries (Included)
- Easy Battery Replacement - No Water Shut Off Necessary
- Removable Filtering System (Easily Cleaned)
- 1 Second Shut Off Delay
- Self-Adjusting Sensor Range
- Automatic Water Flow Shut-Off: 10 Seconds
- Operating Water Pressure: 10-125 PSI
- Easy Installation
- **ASME A112.18.1-2012 and CSA B125.1-12 Compliant**
- **Safe Water Drinking Act Compliant**
- **California Energy Commission (CEC) Compliant**
- **Living Buildings Challenge (LBC) DECLARE. Compliant**
- **ADA Compliant**

**Important:** There is a minimum requirement of 11 inches (275 mm) of clearance from the bottom of the aerator to the basin in order for the sensor to function properly. Any distance less than 11 inches (275mm) may result in sensor error from the reflection of the sink.

## The HYBRIDFLO<sup>®</sup> Advantage

The HYBRIDFLO<sup>®</sup> Automatic Faucet System incorporates patented BRV<sup>®</sup> Technology with a state of the art high quality gear motor drive mechanism. By using a gear motor instead of a solenoid, the HYBRIDFLO<sup>®</sup> Automatic Faucet System achieves a level of reliability rarely experienced with other automatic faucet systems. The spout of the faucet is built of high quality solid brass. The design of the control box allows for easy installation and conceals all mechanical and electrical components. An easy to clean filter assures easy maintenance, long life, and ultimate performance.

The unique design of the HYBRIDFLO<sup>®</sup> Automatic Faucet System allows for the use of various power options including battery power, electrical power (with battery back-up), or an environmentally friendly hydro-power electric generator.



UPC and Low Lead Compliant



## Accessories (Add suffix to model number for accessories)

### Alternate Spray Heads

- SH10 1.0 gpm/3.8 Lpm Spray Head
- SH15 1.5 gpm/5.7 Lpm Laminar Flow Spray Head

### Alternate Power Options

- HG01 Plug-in Hydro-Power Electric Generator
- AD01 Plug-in 6-Volt AC Power Adapter

### Temperature Mixing Valves

- MV Mechanical Mixing Valve (Below Deck)
- TMV Thermostatic Mixing Valve (Below Deck)

Warranty  
5 Years



## Architect/Engineer Approval

Job Name	_____
Date	_____
Model Specified	_____
Quantity	_____
Variations Specified	_____
Customer/Wholesaler	_____
Contractor	_____
Architect	_____



# HYBRIDFLO<sup>®</sup>

## AUTOMATIC FAUCET SYSTEMS

Model  
AEF-305T

### Specifications:

Operation:	Automatic (Gear Motor Drive)
Spout:	Solid Brass Spout
Mounting Applications:	Wall Mounted
Sensor Type:	Infrared
Battery Type:	Four (4) C-Cell
Battery Life:	400,000 Cycles or 3 Years
Alternate Power (optional):	Plug-in 6-Volt AC Power Adapter
	Plug-in Hydro-power Electric Generator
Working Water Pressure:	10-125 PSI
Supply Inlet Size:	1/2" Supply Inlet
Temperature Control:	None (use TMV to mix hot/cold water)
Pop-Up Drain Rod:	None
Sensor Location:	Tip of Spout
Sensor Range Setting:	Digital Push Button
Sensing Range:	Self-Adjusting Sensor Range
Shut-Off Delay Time:	1 Second
Automatic Shut-Off Time:	10 Seconds
Low Battery Indicator:	Solid Red Light on Sensor

### Dimensions:

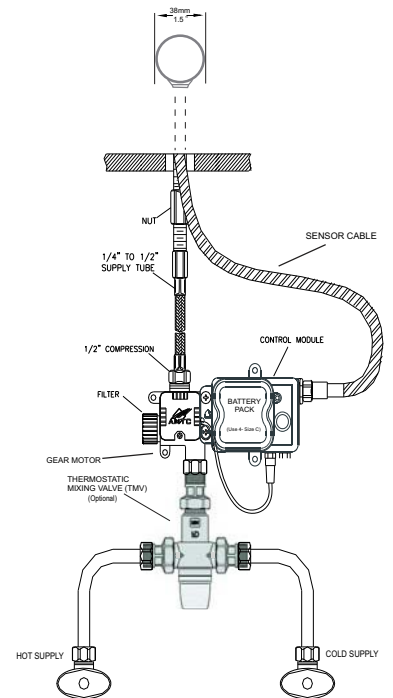
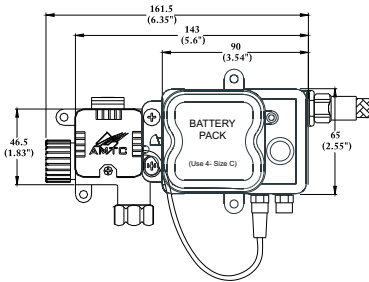
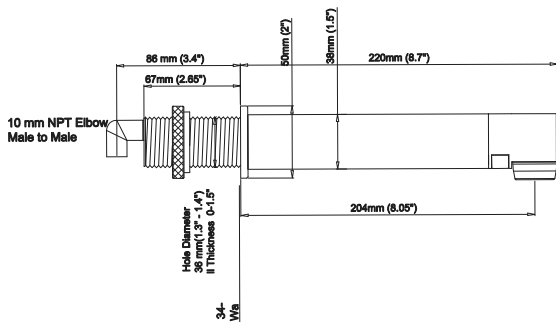

Shown using hot and cold water mixing

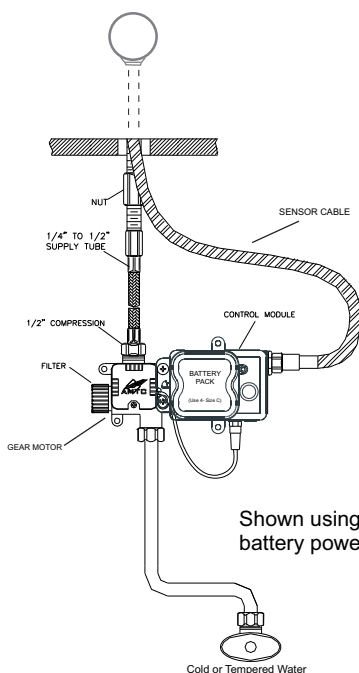

Shown using standard battery power.

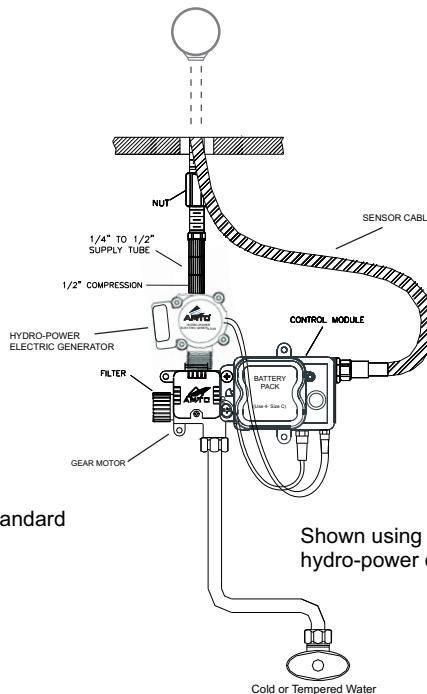

Shown using plug-in hydro-power electric generator.

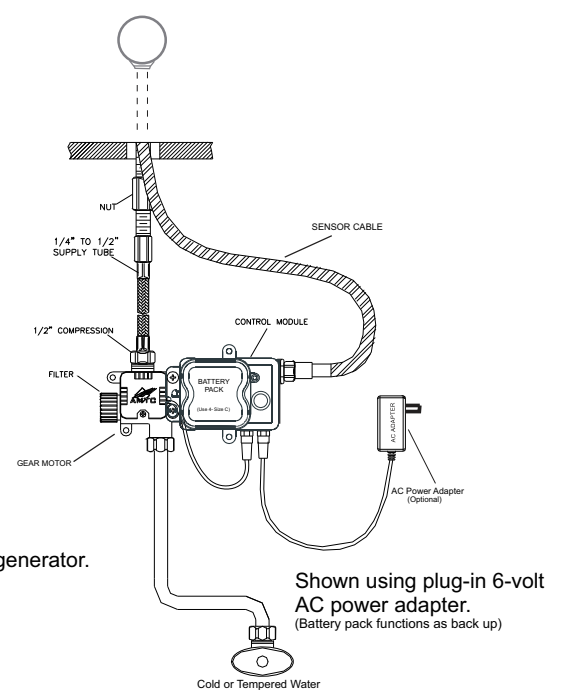

Shown using plug-in 6-volt AC power adapter. (Battery pack functions as back up)

Advanced Modern Technologies Corporation • 19800 Nordhoff Place • Chatsworth, CA 91311  
Tel: (818) 883-2682 • Toll Free: (800) 874-7822 • Fax: (818) 883-2620 • [www.amtcorporation.com](http://www.amtcorporation.com)