



HYBRIDFLUSH[®] AUTOMATIC

ADA Floor Mount Low Consumption Flush Valve System

Model
AEF1012AT16

Description

Battery Powered, Sensor Operated HYBRIDFLUSH[®] Top Mount Complete LC System with Exposed Automatic Water Closet Flushometer and ADA Vitreous China Fixture.

Flush Cycle

Model AEF1012AT16 (1.6 gpf/6.0 Lpf)

Specifications

Flushometer Specification (Model AEF-801-CT-16)

- Patented BRV[®] and Gear Motor Drive
- Hands Free Infrared Sensor Activation
- Vandal and Water Resistant Design
- Chrome Plated All Metal Housing
- Quiet Operation
- True Mechanical Override (Side)
 - *Mechanical Button/Handle Works When Batteries are Drained
- Operates on (4) "AA" Alkaline Batteries (Included)
- Battery Life - 3+ Years
- "Low Battery" Blinking LED Indicator
- Easy Battery Replacement-No Water Shut Off Necessary
- Adjustable Sensor Angle
- Adjustable Sensor Distance
- Optional Three (3) Second Flush Delay Mode
- Optional 24-Hour Flush Mode
- Uses Proprietary Silicone Diaphragm with Filtered Bypass
- 1" I.P.S. Angle Stop
- Adjustable Tailpiece
- High Back Pressure Vacuum Breaker with Single Piece Hex Coupling Nut
- Spud Coupling and Flange for 1 1/2" Top Spud
- Sweat Solder Kit and Wall Flange with Set Screw
- Low Consumption For Water Conservation

Compliance & Certifications

- ASSE 1037-2015
- ASME A112.1035-2015
- CSA B125.37-15



For Finish Variations Please Consult Factory

Accessories (Add suffix to model number for accessories)

HC801 - Cover for Mechanical Flush Button

Fixture Specification (Model AUT-1012A)

- Complies with ADA Accessible Standards
- White Color
- Vitreous China
- Floor Mount Water Closet Bowl
- Elongated Rim
- 10" (254mm) Rough-In
- 1-1/2" (38mm) I.P.S. Top Spud Inlet
- 2" (50mm) Fully Glazed Trapway
- 11-1/2" (292mm) x 13" (330mm) Water Surface Area
- Direct Feed Jet
- 100% Factory Tested
- Toilet Seat Not Included

Compliance & Certifications

- ASME A112.19.2/CSA B45.1
- Energy Act of 1992
- ADA- With installation consideration for section 604 Water Closets, Accessibility Guidelines.
- ICC/ANSI A117.1
- TAS - With installation consideration for section: 4.16.3. Adult seat height 17" (432mm) to 19" (483mm).
- CSA B651 - With installation consideration for Clause 4.3.6 of the standard.
- ICC-ES PMG[®] Certified



Plumbing System Requirements

- Minimum Flowing Pressure: 25 PSI
- Maximum Static Pressure: 80 PSI
- Minimum Flow Rate: 25 GPM



The HYBRIDFLUSH[®] Advantage

The HYBRIDFLUSH[®] is a revolutionary full-featured automatic/manual flush valve system. The HYBRIDFLUSH[®] incorporates a unique patented mechanism that allows for automatic/manual operation for unsurpassed reliability. The patented HYBRIDFLUSH[®] design allows for the original flush handle or push button to be used as an alternate flush option that is independent of the battery power. The HYBRIDFLUSH[®] by Advanced Modern Technologies Corporation is the most efficient, economical, and complete automatic flush valve system on the market.

Warranty
5 Years



Architect/Engineer Approval

Job Name	_____
Date	_____
Model Specified	_____
Quantity	_____
Variations Specified	_____
Customer/Wholesaler	_____
Contractor	_____
Architect	_____

The information contained in this document is subject to change without notice.
Revision (10/17)



Specifications

Operation:	Hybrid (Automatic/Manual)
Outer Casing:	Standard-Chrome Metal
Operating Water Pressure:	15 PSI - 100 PSI
Sensor Type:	Infrared
Battery Type:	Four AA Alkaline Batteries
Battery Life:	3+ Years
Arming Delay:	5 Seconds
Flush Delay:	3 Seconds
Sensing Range:	18" (45cm) - 30" (75cm) Adjustable
Ghost Flush:	Once every 24 Hours From Last Flush
Sensor Angle:	Adjustable Angle
Flush Cycle:	Specified by Model
Model AEF1012AT16	1.6 gpf/6.0 Lpf
Flush Mode:	After Every Use
Manual Override:	Mechanical Flush Button or None

Dimensions

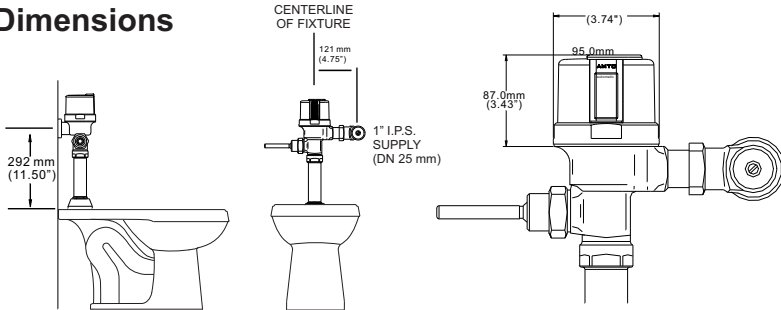

Application

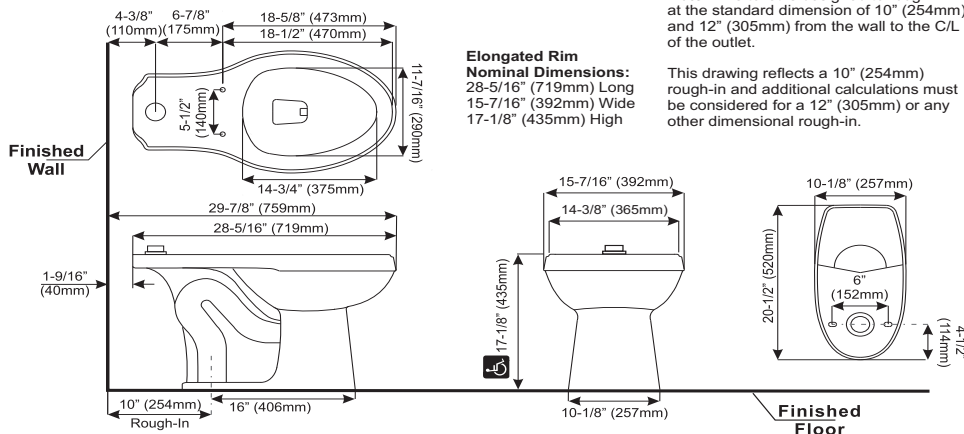
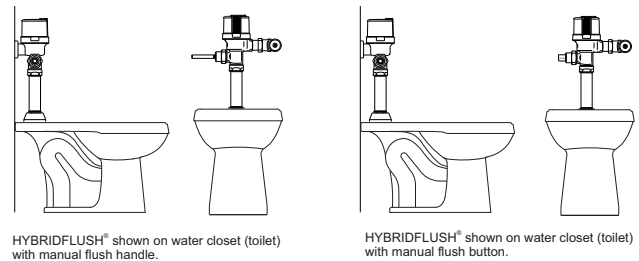

4840 York Blvd Los Angeles CA 90042
 www.CandLsupply.com
 Toll Free: (800) 458-2377 | Fax: (323) 258-6523
 sales@CandLsupply.com

Disclaimer

Note: All vitreous china dimensions shown in these drawings are nominal and not to scale. Dimensions can vary within the tolerances established in the governing ASME A112.19.2/CSA B45.1 standard. It is important to consider this when planning rough-in and plumbing layouts.

Advanced Modern Technologies Corporation • 19800 Nordhoff Place • Chatsworth, CA 91311
 Tel: (818) 883-2682 • Toll Free: (800) 874-7822 • Fax: (818) 883-2620 • www.amtccorporation.com