

# ELBA INSTANT WATER HEATER

**EWH-Q4211(SB)      EWH-Q4211(MB)**  
**EWH-Q4215DC(SB)      EWH-Q4215DC(MB)**  
**EWHR-Q4218DC(SB)      EWHR-Q4218DC(MB)**

## Owner's Manual

Please read this manual carefully before operating your set.  
Retain it for future reference.

Record model number and serial number of the set.

See the label attached on the set and quote this  
information to your dealer when you require service.

**For The Warranty Terms & Conditions, Please Refer To Warranty Certificate.**

Thank you for purchasing ELBA Instant Water Heater.  
Please read this manual thoroughly and understands the content before use.



## SAFETY PRECAUTION

1. This appliance is not to be used for a portable water supply.
2. The appliance is not be used by persons (including children) with reduced physical sensory or mental capabilities, or lack of experience and knowledge, unless they have been given supervision or instruction concerning use of the appliance by a person responsible for their safety.
3. Keep this appliance out of reach of children. Close supervision is necessary when the appliance is operating near children or infirm persons. Children being supervised to ensure that they do not play with the appliance.
4. Do not install reverse INLET & OUTLET of heater.
5. The water inlet of appliance shall not be connected to inlet obtained from any other water heating system.
6. Do not install the heater where there is consistent spray directly over the unit.
7. Do not connect the OUTLET to any tap or fitting that is not recommended by the manufacturer.
8. Do not block the heater OUTLET in any way.
9. Do not attempt to repair the heater without qualified technician.
10. Do not leave children, elderly or disable person alone in shower.
11. Engage qualified electrician for installation.
12. Test water temperature with hand before using the shower.
13. Check the ELCB once a month (please refer to the RUN of Heater) and consult professional for repair if there is any malfunction.
14. Metallic / chrome flexible hose and conductive control valve shall not be used.
15. Do not leave the hand shower idle in the pail.

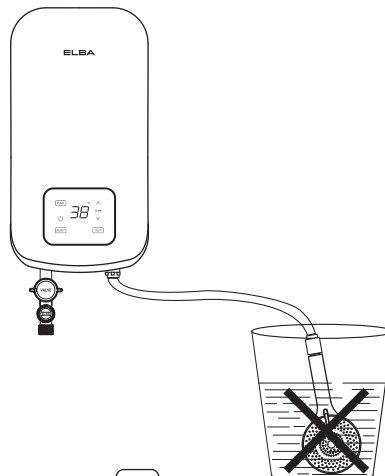

# 1. WATER HEATER PARTS IDENTIFICATION

## EXTERNAL PARTS IDENTIFICATION

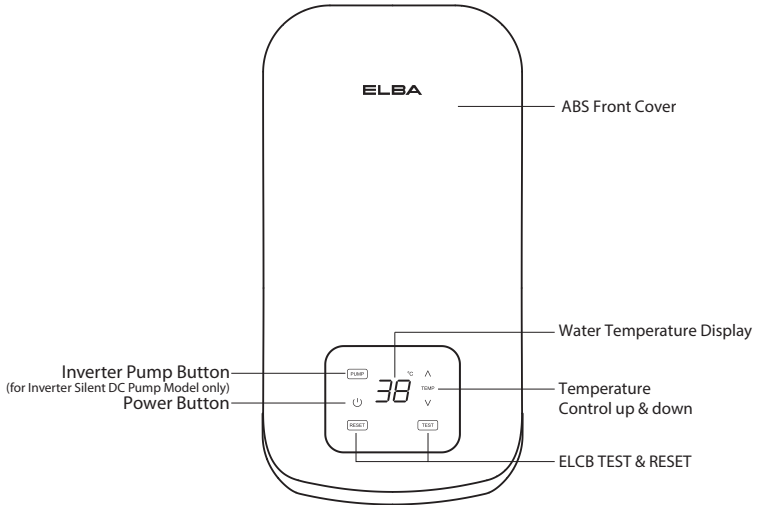

## INTERNAL PARTS IDENTIFICATION

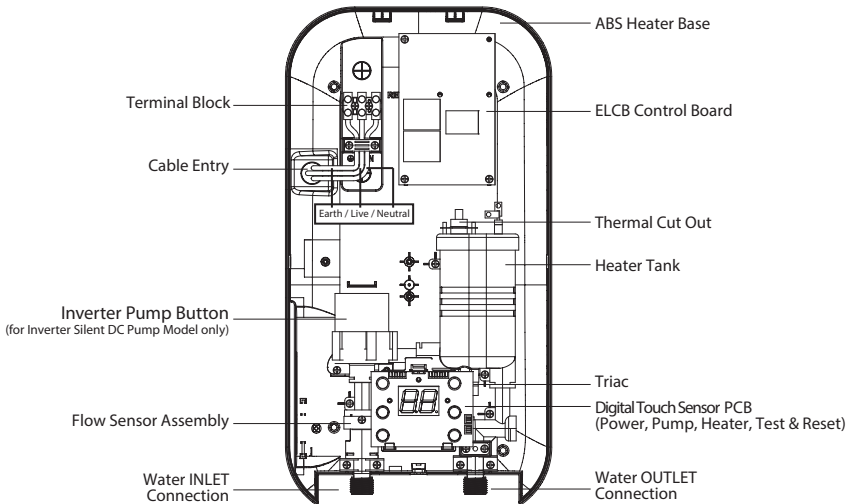

**SHOWER SET ACCESSORIES IDENTIFICATION**

**1. MATTE BLACK ACCESSORIES**

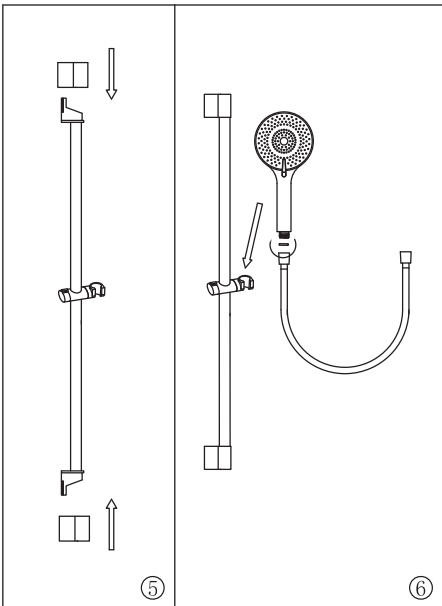
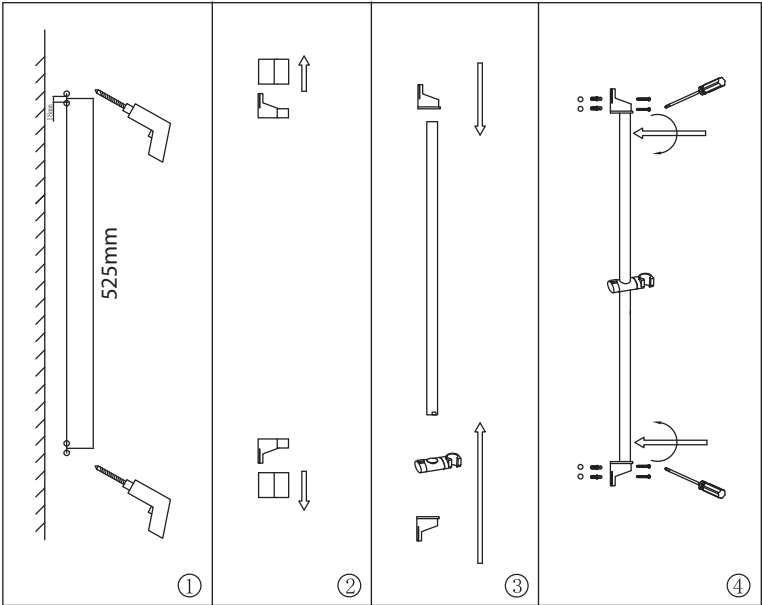

# SHOWER SET ACCESSORIES IDENTIFICATION

## 2. MATTE BLACK ACCESSORIES (RAIN SHOWER)

(Optional Features)

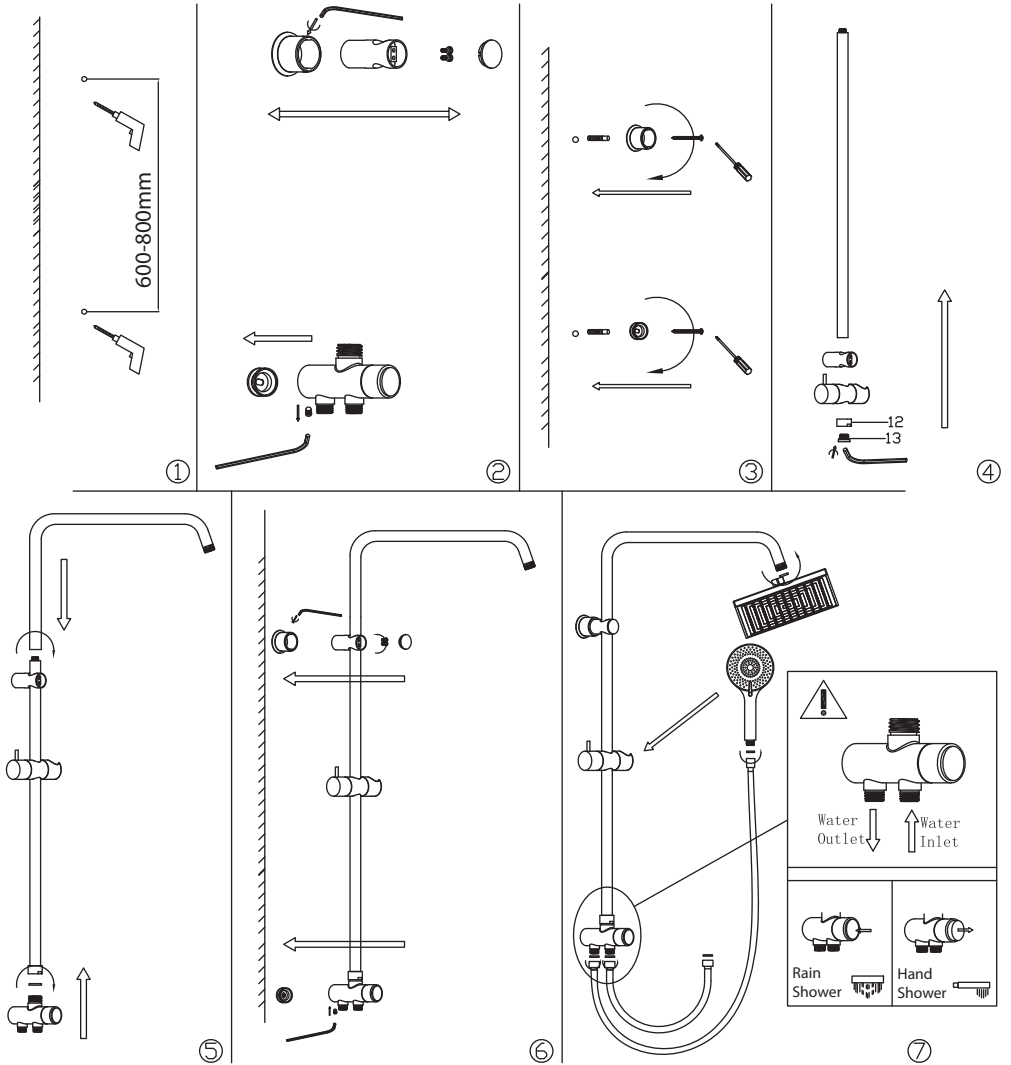

## 2. GENERAL INFORMATION

### INSTALLATION



**CAUTION:**  
**THIS APPLIANCE MUST BE EARTHED.**

- All the plumbing work should be completed before proceeding to electrical wiring connection. (Table 1)
- Installation must be carried out by a qualified electrician with close reference to the operation manual and in compliance with the local regulations.
- The unit works at minimum water flow rate of 2 litre/min, which then would trigger the built-in pump (only for pump model), boosting a stronger shower spray.
- The built-in electronic Earth Leakage Circuit Breaker (ELCB) would cut-off the power supply to the heater in the event of current leakage of as low as 15mA.
- The Thermal Cut-Off would automatically shut off the power supply shall there be any abnormal rise of showering temperature.
- The unit only operates when there is sufficient water flow to trigger the flow switch.
- Electrical loading Table 1 :

Voltage (Vac)	Power (kW)	Amperes (A)	Recommended Conductor Size (csa)			Fuse/ MCB(A)	ON/OFF Switch (A)
			mm <sup>2</sup>	Conduit Cable	Flexible Cable		
220 - 50/60Hz	3.5	16.0	2.5	7/0.67mm	50/0.25	20	20
	4.5	20.5	2.5	7/0.67mm	56/0.30	25	25
	5.5	25.0	4.0	7/0.85mm	56/0.30	32	32
	6.0	27.3	4.0	7/0.85mm	56/0.30	32	32
	6.5	29.6	4.0	7/0.85mm	84/0.30	32	32
	7.5	34.1	6.0	7/1.04mm	84/0.30	40	40
230 - 50/60Hz	3.5	15.2	2.5	7/0.67mm	50/0.25	20	20
	5.5	24.0	4.0	7/0.85mm	56/0.30	32	32
	6.6	28.7	4.0	7/0.85mm	56/0.30	32	32
	8.8	38.3	6.0	7/1.04mm	84/0.30	40	40
240 - 50/60Hz	3.6	15.0	4.0	7/0.85mm	56/0.30	32	32
	3.8	15.8	4.0	7/0.85mm	56/0.30	32	32
	4.25	17.7	4.0	7/0.85mm	56/0.30	32	32
	7.7	32.1	6.0	7/1.04mm	84/0.30	40	40
	9.0	37.5	6.0	7/1.04mm	84/0.30	40	40

- The appliances should be connected to the water mains with NEW hose- sets. Old hose-sets should not be reused.
- Instantaneous water heater's shall be equipped with a 2 pole control switch and is own residual current device.
- Water heaters exceeding 3kW shall be permanently connected to a 20A/30A rated circuit breaker / fuse with an isolator switch and residual current device.

### 3. INSTALLATION PROCEDURES

1. All the plumbing works should be completed before proceeding to electrical wiring connection.
2. INLET and OUTLET connection of the heater unit should not be reversed, with stop valve installed on INLET. (Diagram 1)
3. It is recommended that the unit should be mounted above 1.5m or 5-feet above the floor to bottom of the heater. (Diagram 1)
4. Mark mounting position. (Diagram 2)
  - Remove screw at the bottom of the heater
  - Lift the plastic cover upward
  - Mark mounting position on the wall
  - Drill the holes with 5mm diameter drill bit
  - Install the unit to the wall with plug

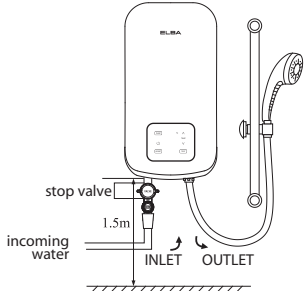

Diagram 1

- Remove screw at the bottom of the heater
- Lift the plastic cover upward
- Mark mounting position on the wall
- Drill the holes with 5mm diameter drill bit
- Install the unit to the wall with plug

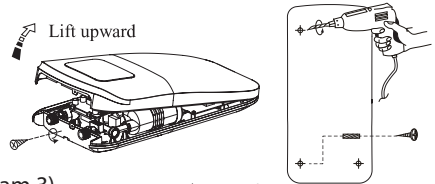

Diagram 2

5. Heater INLET and OUTLET Connection. (Diagram 3)

- Connect the stop valve to INLET**, and be sure to put a gasket to prevent water leakage.
- Connect the piping from the stop valve to incoming water supply. If necessary make use of sealing tape for the connection to prevent water leakage.
- Connect flexible hose to heater OUTLET. Turn on the water mains to drain out all the plumbing dirt and fill up the heater tank. Then, connect the flexible hose to the hand shower.  
(Note: This step will prevent damage to the heating element).

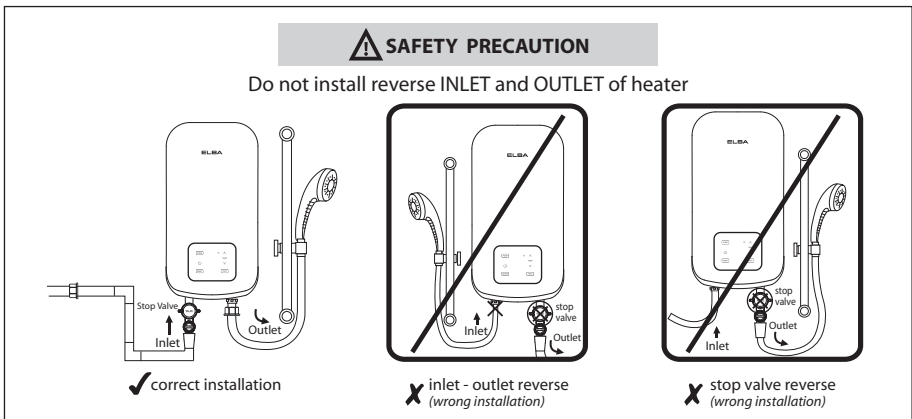

Diagram 3

## 6. Electrical Connection

### IMPORTANT NOTE !

SWITCH OFF THE MAIN SUPPLY  
BEFORE ELECTRICAL WORK

- Insert electrical cable through the rubber grommet as shown.
- Connect the cable to the terminal block and fully tighten them as the following:-
  - Red or Brown.....Live (L)
  - Black or Blue.....Neutral (N)
  - Green or Green / Yellow.....Earth (⊕)
- Restore the cover and secure screw at the bottom. (Diagram 4)

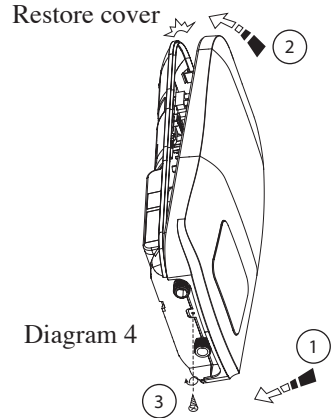

Diagram 4

### CODE DISPLAY

Code Description

- |           |   |
|-----------|---|
| <i>BB</i> | Auto Test (Auto Checking of the internal circuit to detect any possible current leakage)                      |
| --        | No water supply   |
| <i>F0</i> | Earth line error (Improper electrical wiring is detected)   |
| <i>F1</i> | ELCB cut off (Power supply cuts off automatically when unit has current leakage)                              |
| <i>F2</i> | Temperature display error (Display board wiring/ connectivity issues)   |
| <i>F3</i> | Temperature sensor error (Thermal sensor malfunction)   |
| <i>F4</i> | Thermostat cut off (Auto thermal cut-out at 55°C) (85°C Abnormal overheat cut-off - manual reset is required) |

ON PUMP ON  
OFF PUMP OFF  
\*DC PUMP MODEL ONLY.

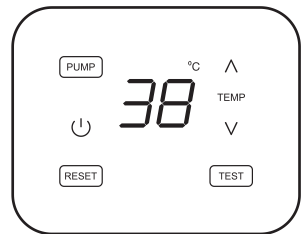



Diagram 5

### Test Run Of Heater

- Turn on the stop valve and water should spray out from the head.
- Switch on the main power supply (panel would light up *BB*).
- Touch power icon to ON water heater and panel showing current water temperature.
- Touch on the Temperature Control icon and panel showing current water temperature. The water should be warmed in a few seconds.
- Touch 'PUMP' icon ON/OFF switch to accelerate water flow and vice verse. (For Pump model only)
- Test the ELCB by touch 'TEST' icon. The unit should be tripped. Digital Panel showing (F1) blinking.
- Touch 'RESET' icon, The unit should resume to normal condition.
- The heater is now ready for use.



## 4. OPERATION PROCEDURE

1. Switch ON the main power supply, the screen panel ( *BB* ) would light up.
2. Touch the POWER (  ) icon to ON water heater.
3. Touch the up & down (  ) icon to control water temperature.
4. Touch icon( PUMP )for boosting a stronger shower spray.
5. Pump On would show on and Pump off would show oF.  
(only for DC pump model)
6. Touch the POWER to OFF the Water heater when no in use.
7. Switch off the main switch when no in use.

## 5. GENERAL MAINTENANCE

### 1)DO NOT USE THINNER, ALCOHOL OR PETROL

You may clean the heater with a damp cloth and mild detergent but do not use thinner, alcohol, petrol or any other organic solution.



### 2) THE SPRAY HEAD MUST BE DESCALED REGULARLY. CLEAN FILTER REGULARLY (DIAGRAM 6 & 7)

- a) Remove the filter mesh from the stop valve (for filter type only) by turning the knob filter counter clockwise and pulling out the knob (Diagram 6). Flush it with water to remove any trapped sediments. Install the knob filter back to its original position.
- b) Clear the shower head's holes by using a soft brush from time to time (Diagram 7). Recommended to clean it once a week. Be careful not to damage the holes of the shower head during cleaning.

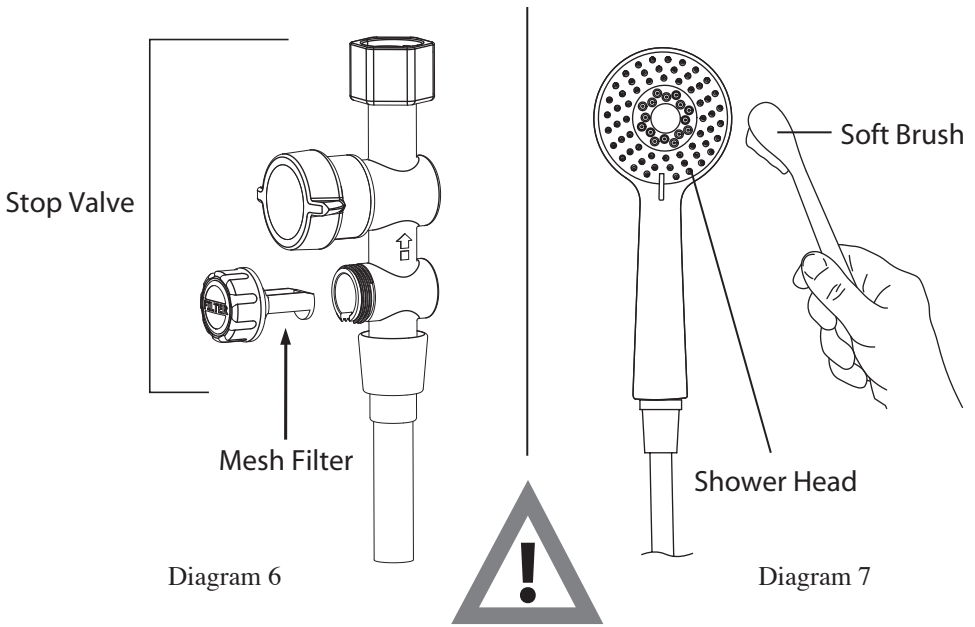

## CLEAN FILTER MESH REGULARLY

### 6. TECHNICAL SPECIFICATION

Electrical loading	4.25kW 240V 50/60Hz
Other Range	Please refer Electrical loading Table 1
ELCB sensitivity	15 mA
Operating Condition	Open System (Open Outlet)
Water Connection	Ø 15 mm (1/2" BSP)
Degree of Protection	IP25
Minimum Water Flow Rate	2 litre/min
Minimum Water Pressure	20kPa (0.2 bar / 2.9psi)
Maximum Water Pressure	4 bar ( 0.6kPa / 87psi )
Heater Dimension (mm)	442(H) x 230(W) x 70(D)
Heater Nett Weight	Non Pump 1.3kg DC Pump 1.5kg

Notes: The specification, actual product's design and accessories parts shown are correct at the time of printing and subject to change without prior notices.

## 7. SCHEMATIC WIRING DIAGRAM

INVERTER DC PUMP : EWH-Q4215DC(SB), EWH-Q4215DC(MB)  
 EWHR-Q4218DC(SB), EWHR-Q4218DC(MB)

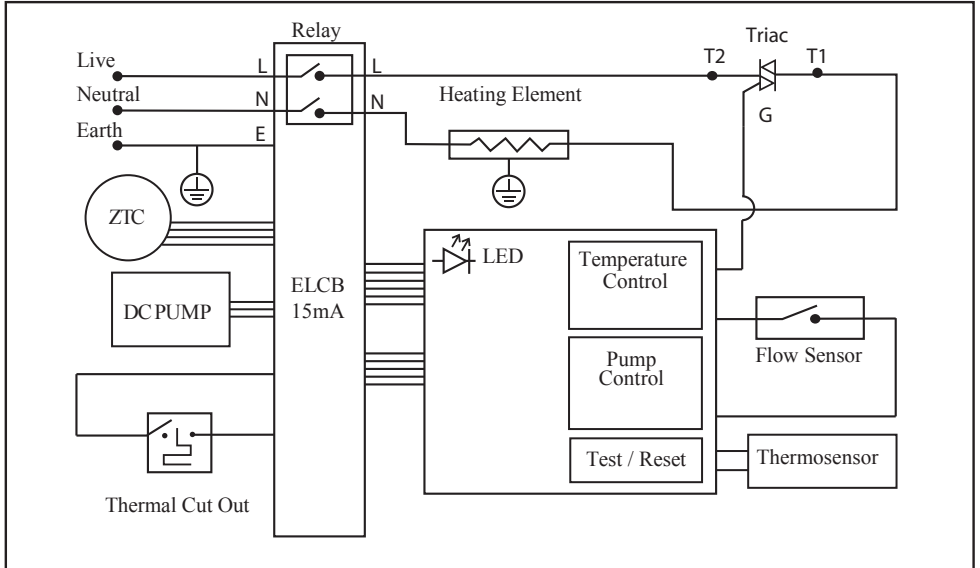

NON-PUMP : EWH-Q4211(SB), EWH-Q4211(MB)

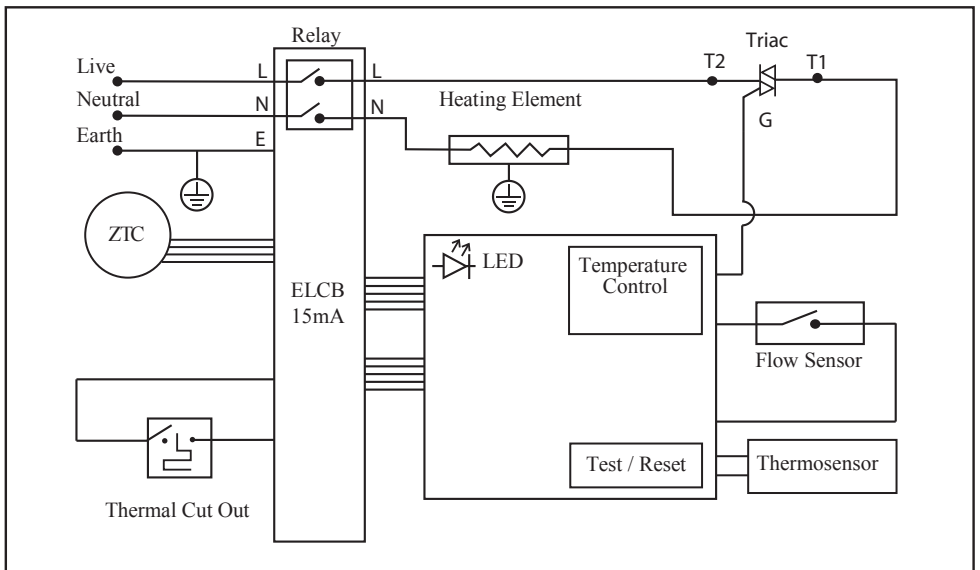

**ELBA**