



ELBA

WALL FAN
MODEL: EWMF-E1645(BK)

Owner's Manual

Please read this manual carefully before operating your set.

Retain it for future reference.

Record model number and serial number of the set.

See the label attached on the set and quote this information to your dealer when you require service.

For The Warranty Terms & Conditions, Please Refer To Warranty Certificate

REMOVE ALL PACKING MATERIALS FROM THIS PRODUCT BEFORE USING IT. THIS APPLIANCE MUST BE INSTALLED ON A FLAT SURFACE. PLEASE ENSURE THE ELECTRIC SUPPLY TO THIS APPLIANCE IS DISCONNECTED BEFORE INSTALLING.

Please read this instruction carefully. It is advisable to keep this instruction manual in a safe place for future reference.

SAFETY PRECAUTIONS

1. Keep electrical appliances out of reach from children. Do not let them to operate the appliances without supervision.
2. To protect against the risk of electrical shock, do not immerse the product, cord or plug into water or any other liquid.
3. This product is for household and indoor use only.
4. This product is not intended for use by person (including children) with reduced physical, sensory or mental capabilities unless they have been given supervision or instruction concerning use of the appliance by a person responsible for their safety.
5. If the power cord or plug is damaged, it must be replaced by the service centre or a qualified service technician to avoid hazard.

WARNING - to reduce the risk of fire, electrical shock or injury to persons or property, please read and follow below instructions carefully:

- Always operate the product from a power source of the same voltage, frequency and rating as indicated on the product identification marking.
- Do not operate this product if it has malfunctioned, damaged cord or plug or appears damaged in any way. Return the complete product to the place of purchase for inspection, repair or replacement.
- This product should not be used in the immediate vicinity of water, such as bathtub, washbowls, swimming pool etc. where the likelihood of immersion or splashing could occur.
- Always switch off and unplug the plug from outlet when not in use, before assembling or disassembling parts and before cleaning. Fully assemble the fan before operating.
- Avoid contacting with moving parts. Do not insert any object through the guard when the fan is operating.
- Do not cover the guard or operate in close proximity to curtains, etc.
- Always disconnect the fan when moving it from one location to another.

PRODUCT DESCRIPTIONS

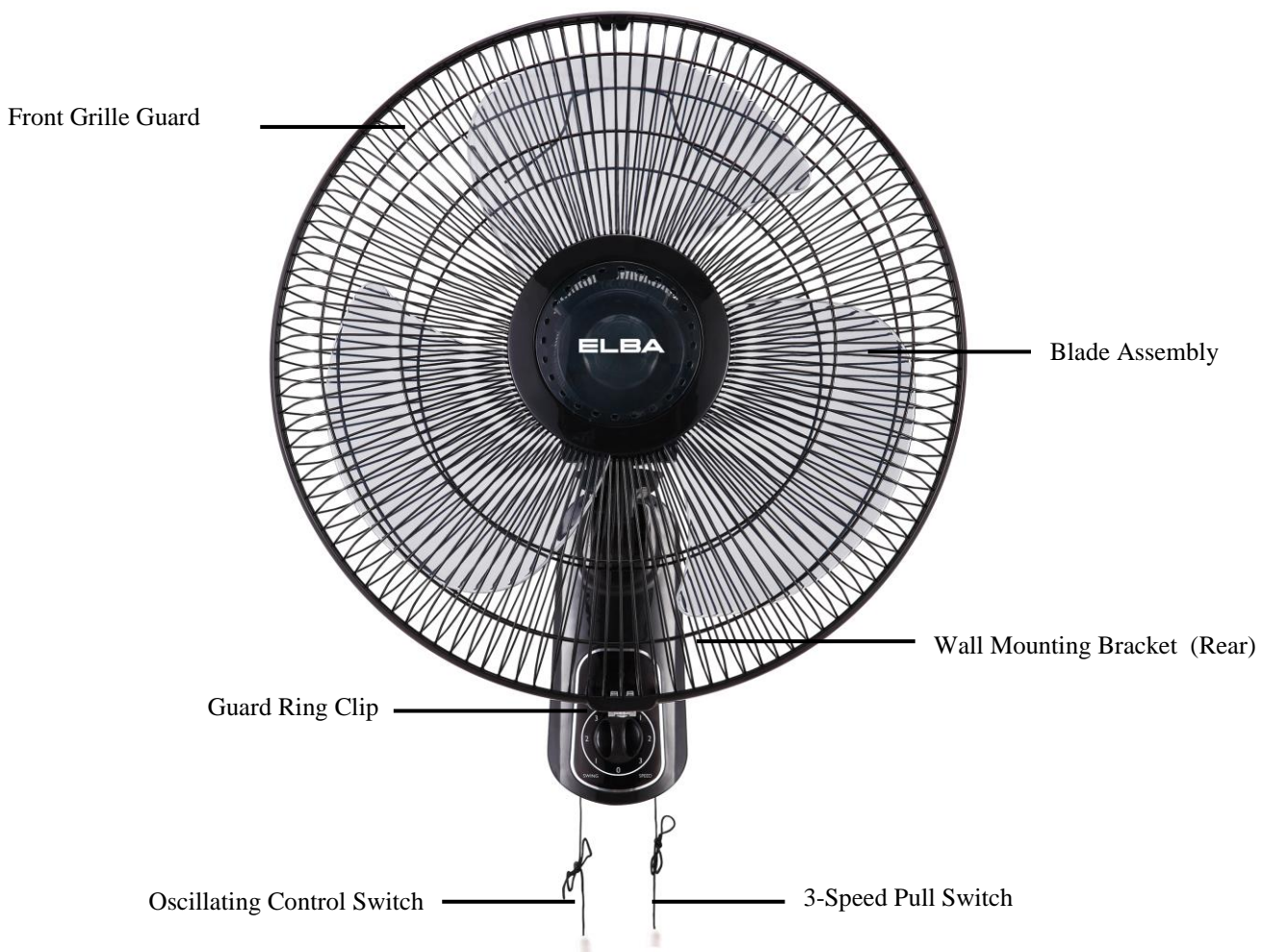

ASSEMBLY INSTRUCTIONS

1. Remove all packaging material and wire fastener from the product.
2. Drill 3 holes on the wall with a distance complied with the hole on the wall bracket (2).
3. Press the screw anchors provided into holes.
4. Mount the hanging bracket (2) on the wall with three screws (1) provided (Fig 1).



(Fig 1)

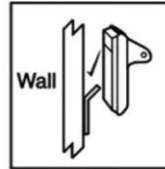

(Fig 2)

5. Hang the rear motor (3) with the holes (11) fixed onto the hanging bracket (2) (Fig 2).
6. Remove the protecting tube (12) from the motor shaft.
7. Loosen the rear guard locking nut (5) from the motor & housing assembly (A).
8. Position the rear guard (4) firmly to the motor & housing assembly (A) and fasten by turning the rear guard locking nut (5) clockwise tightly.
9. Push the fan blade (6) along the motor shaft. Fasten securely using the fan blade locking nut (7) by turning anticlockwise.
10. Press the front guard (8) to attach with rear guard (4) until both guards are properly fitted (Fig 5). Secure both guards firmly by tightening the guard ring clip (9) (Fig 6).

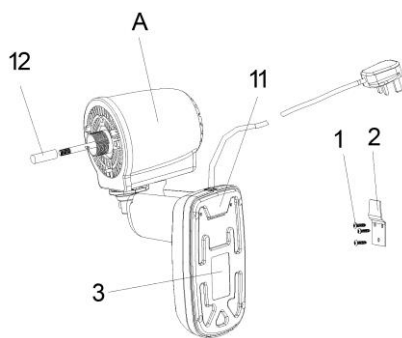

(Fig 3)

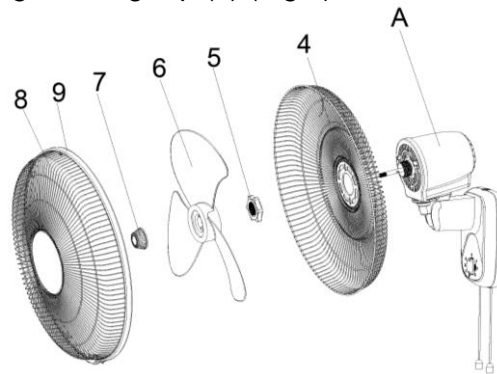

(Fig 4)

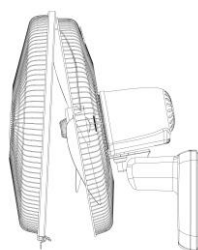

(Fig 5)

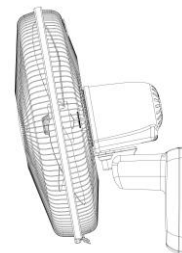

(Fig 6)

OPERATING INSTRUCTIONS

1. Operate the relevant speed by pulling the switch for the required fan speed. '0' to turn OFF, '1' for Low Speed, '2' for Medium Speed and '3' for High Speed.
2. To make the fan head oscillate, pull the oscillating control switch. To stop the oscillation, pull the oscillating control switch again.

WARNING: Do not adjust the oscillating angle by hand. It will damage the synchronous motor.

3. To adjust the tilt of the fan head, firstly fix the body with one hand and then push the motor part up or down to adjust it to the appropriate position.

WARNING: The fan should be switched off when making this adjustment.

NOTE: The fan head will not latch into the low or mid position until the guard and blade are fitted to the motor.

CLEANING AND MAINTENANCE

Clean the appliance with a damp cloth with mild cleaner. Do not use chemical, steel, wooden or abrasive cleaners to clean the appliance.

WARNING: DO NOT IMMERSE THE APPLIANCE INTO WATER. ENSURE THAT THE FAN IS UNPLUGGED FROM THE POWER SUPPLY BEFORE REMOVING THE GUARD.

MAIN SPECIFICATION

Voltage : 220-240V/50Hz

Rated Power: 55W

Fan Size : 16-inch

Motor : 3-Speed

NOTICE

This product must not be disposed together with domestic waste. It has to be disposed at an authorized place for recycling of electrical and electronic appliances. By collecting and recycling waste, you help to save natural resources and make sure the product is disposed in an environmental friendly and healthy way.



ELBA