



ELBA

BUILT-IN STEAM OVEN MODEL: ESGO-H3850TFT(BK)

Owner's Manual

Please read this manual carefully before operating your set.

Retain it for future reference.

Record model number and serial number of the set.

See the label attached on the set and quote this information to your dealer when you require service.

For The Warranty Terms & Conditions, Please Refer To Warranty Certificate

CONTENTS

1. SAFETY PRECAUTIONS.....	1
2. ATTENTIONS.....	2
3. INSTALLATION.....	2
3.1 BEFORE THE INSTALLATION.....	2
3.2 INSTALLATION OF BUILT-IN OVEN.....	3
3.3 ACCESSOIRES.....	4
4. CONNECTION OF THE APPLIANCE.....	4
4.1 FITTING ON A POWER SUPPLY CABLE.....	4
4.2 CONNECTING THE SUPPLY CABLE TO THE MAINS.....	4
5. HOW TO USE YOUR OVEN.....	5
6. PRODUCT DESCRIPTIONS.....	5
6.1 PRODUCT OVERVIEW.....	5
6.2 OVEN CONTROL PANEL.....	6
6.3 DISPLAY DESCRIPTIONS.....	7
6.4 MAIN MENU	7
6.5 SYMBOL	8
7. PROGRAMS AND FUNCTIONS.....	9
7.1 SELECTING THE COOKING PROGRAMS.....	9
7.2 SETTING FOR THE FIRST TIME.....	9-12
7.3 OVEN OPERATION.....	13-14
7.4 CHECKING THE WATER TANK.....	14
7.5 END OF THE PROGRAM.....	15
7.6 CHANGE THE RUNNING PROGRAM.....	15
7.7 CANCEL THE RUNNING PROGRAM.....	16
7.8 CHILD LOCK.....	16
7.9 KITCHEN TIME (REMINDER).....	16
7.10 DESCALING FUNCTION.....	17-19
8. CLEANING AND MAINTENANCE.....	20-21
9. TROUBLESHOOTING.....	22
10. TECHNICAL SPECIFICATION.....	22

We recommend that you read the instructions in this owner's manual carefully before using it for the best performance and to extend the lifespan of your appliance, as it will provide you with all the instructions you require to ensure its safe installation, use and maintenance.

1. SAFETY PRECAUTIONS

- In order to avoid bump against people or oven during transportation, please grip the handle on the two external sides. Do not carry the appliance at the front handle, this might damage the oven door.
- To ensure your safety, all electric appliances should only be installed or serviced by qualified technician. If the supply cord is damaged, it must be replaced by the authorized service center or similarly qualified technician in order to avoid hazard.
- Do not place supply cord on the edge of table and counter, or near any heating appliance.
- In order to avoid electric shock, do not immerse supply cord, plug or other parts into water.
- Do not place the appliance near electric stove, heated oven, microwave or other heat source.
- In order to avoid burning or explosion, combustibles or flammable material (curtains, cloth, wallpaper and others) should be kept away from the appliance.
- Do not place paperboard, plastic or other similar items in the oven. When the oven is not being used, everything should be removed except provided accessory.
- Do not cover slag pan or other parts with tinsel since it will result overheat.
- Accessible parts may become hot during use, please keep away from children.
- Never obstruct vents provided for ventilation and heat dispersal.
- The ends of door handle may become hot during use, please grip the middle parts.
- When the appliance is faulty, please contact the authorized service center.
- Always use insulation gloves to carry ovenware or handle oil plate.
- Disconnect the oven from the power supply and waiting until it is cool, before cleaning or maintenance.
- In order to avoid electric shock, never use wire brush to clean the appliance since pieces of metal is easy to touch live part.
- Never use metal scouring pads or sharp scrapers which will damage the door surface or interior wall, leading to glass broken or scratches of the enamel.
- In order to avoid burn or electric shock, never put too much food or metal utensils.
- Please make sure the oven function has been switched off when it is not be used.
- Unplug from the socket when you are planning not to use the oven for long time.
- Never use your oven outside the cabinet.
- Other purpose except baking is not allowed.
- Do not lean or rest on the opened oven door. This may damage the oven. The door can bear a maximum weight of 8 kg.

2. ATTENTIONS

- In order to avoid electric shock, please make sure the oven has been shut off before carrying out the maintenance.
- Use only original accessories provided by ELBA or its authorized service center.
- Do not use wet parts of body to touch the oven.
- Do not pull and push the oven by its supply cord, this may lead to socket disconnection.
- Improper or dangerous operations are forbidden.
- Do not let the power cord of other appliances to touch the heated parts of the oven.
- The oven should not be exposed to rain or direct sunshine.
- Do not use or store flammable objects near to the oven.

Distributors decline all liability for not following above instructions or some improper operations which caused personal injury and property loss.

3. INSTALLATION

3.1 Before the Installation

- Please check the products and make sure that there is no damage caused by striking or heavy load.
- The oven door is level, and you can open and close the oven door flexibly.
- Specification on the marking plate is in compliance with the regulations.

If the oven appears in an abnormal way, do not install and unplug the power supply before contacting the authorized service center. Do not attempt to repair or service the oven by yourself. Repair or maintenance should only be carried out by a qualified technician or the authorized service center.

This appliance must be installed only by qualified technician or the authorized service center. Manufacturer declines all responsibility for improper installation, which may harm persons and cause damage to the property.

Important:

- The power supply to the appliance must be cut off before any adjustments or maintenance work is carried out.
- The AC power supply should be supplied with 220-240V, 50/60Hz with minimum 15A distribution circuit fuse or at least 15A distribution circuit breaker.

3.2 Installation of Built-in Oven

The material of the cabinet should be insulated, and the clearance between the edge of the cabinet and the oven should be over 100mm for ventilation. The panels of the adjacent cabinets must be made of heat-resistant material which can withstand temperatures of up to 100°C. In compliance with current safety standards, contact with the electrical parts of the oven must not be possible once it has been installed.

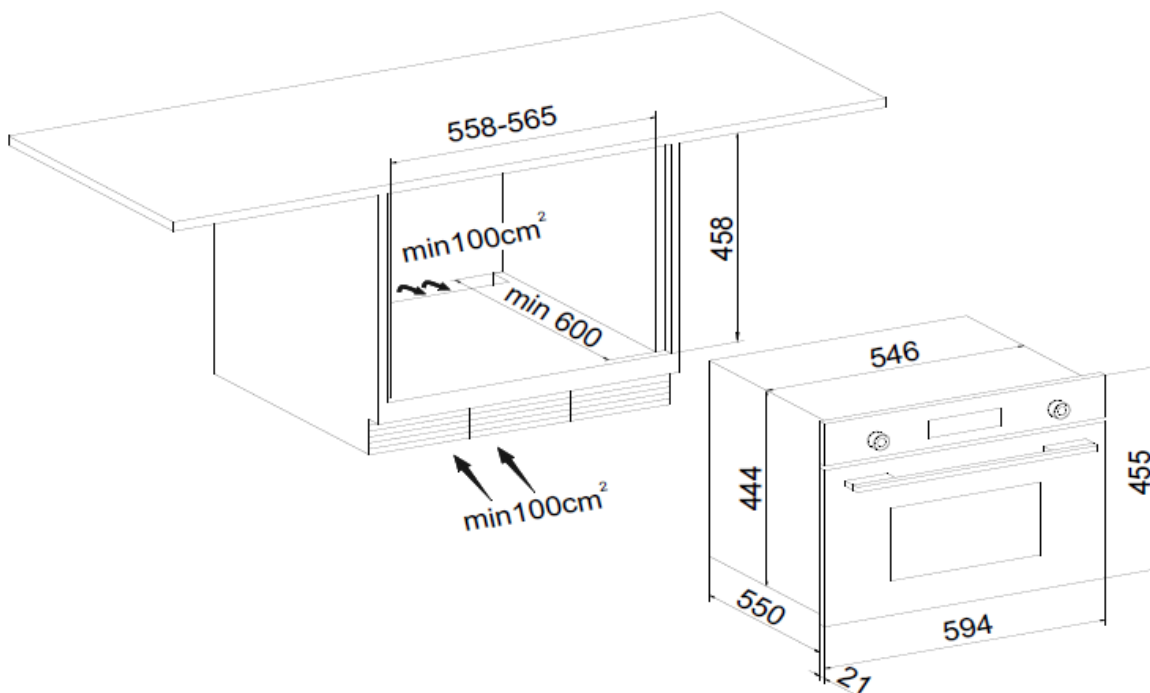

Install 4 screw on the inner side of the oven door frame to fix the position.

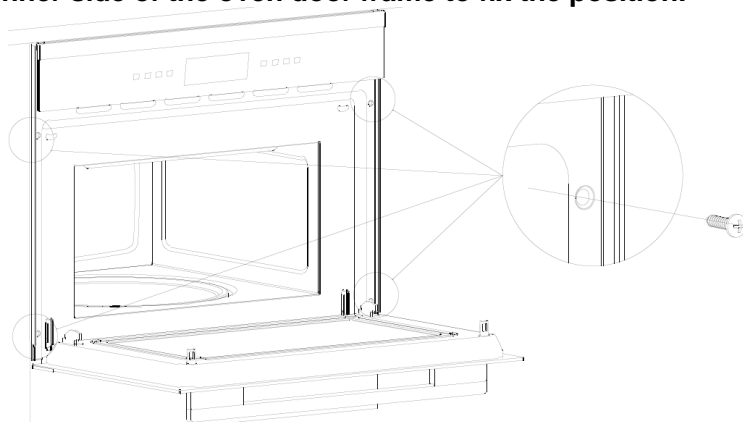

Note: Please do not use the handle to carry or move the oven during installation or handling.

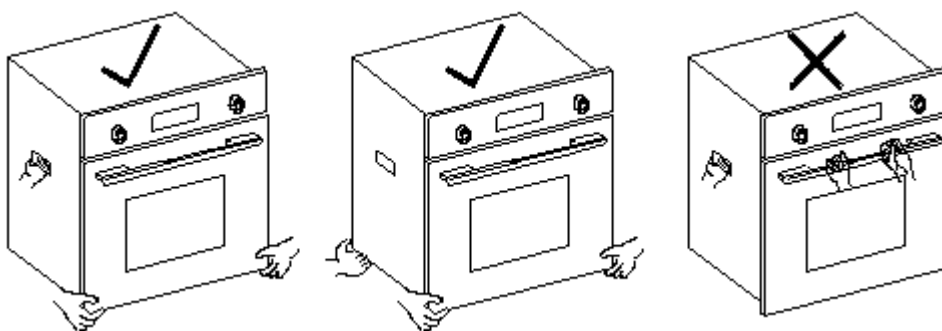

3.3 Accessories

The following accessories are provided with your oven.



1. Wire rack



2. Steam tray



3. Drip tray

4. CONNECTION OF THE APPLIANCE

4.1 Fitting on a Power Supply Cable

The appliance has to be equipped with a three-core power supply cable which is designed to operate with an alternating current. The AC power supply should be supplied with 220-240V, 50/60Hz and a minimum 15A distribution circuit fuse or at least 15A distribution circuit breaker.

4.2 Connecting the Supply Cable to the Mains

Install a standardized plug corresponding to the load indicated on the marking plate. The supply cable should be positioned so that it does not reach a temperature of more than 50°C with respect to the room temperature, anywhere along its length, or protected by insulation having an appropriate rating.

Before making the connection, check that:

- The electrical safety of this appliance can only be guaranteed if the appliance is correctly and efficiently earthed, in compliance with regulations on electrical safety.
- Always ensure that the earthing is connected. If you have any doubts please contact a qualified technician to check the connection. The manufacturer declines all liability of damage resulting from a connection which has not been earthed properly.
- Before plugging the appliance into the mains, check that the specifications indicated on the marking plate correspond to the electrical mains system of your home.
- Check that the electrical capacity of the system and sockets will support the maximum power of the appliance, as indicated on the marking plate.
- If the socket and appliance plug are not compatible, have the socket replaced with a suitable model by a qualified technician. The latter, in particular, will also have to ensure that the cross sections of the socket cables are suitable for the power absorbed by the appliance.
- The use of adapters, multiple sockets and /or extensions, is not recommended. If their use cannot be avoided, remember to use only single or multiple adapters and extensions which comply with current safety regulations. In these cases, never exceed the maximum current capacity indicated on the single adapter or extension and the maximum power indicated on the multiple adapter. The plug and socket must be easily accessible.

5. HOW TO USE YOUR OVEN

- The first time you use your appliance, we recommend that set the thermostat to the highest setting and leave the oven on for about half an hour with nothing in it, with the oven door shut completely. Then open the oven door and let the air in. The odor that is often detected during this initial use is due to the evaporation of substances used to protect the oven during storage and until it is installed.
- Place the drip tray provided at the bottom shelf of the oven to prevent any sauce and/or grease from dripping onto the bottom of the oven only when grilling food or steaming. For all other types of cooking, never use the bottom shelf and never place anything on the bottom of the oven when it is in operation because this could damage the enamel. Always place your cookware (dishes, aluminum foil, etc.) on the grilling rack provided with the appliance inserted especially along the oven guides.
- After baking food contains sugar and salt, please clean your oven promptly, or these will attach to the oven surface.
- Use baking tray to roast high temperature food such as meat, poultry, fish, and others.

6. PRODUCT DESCRIPTION



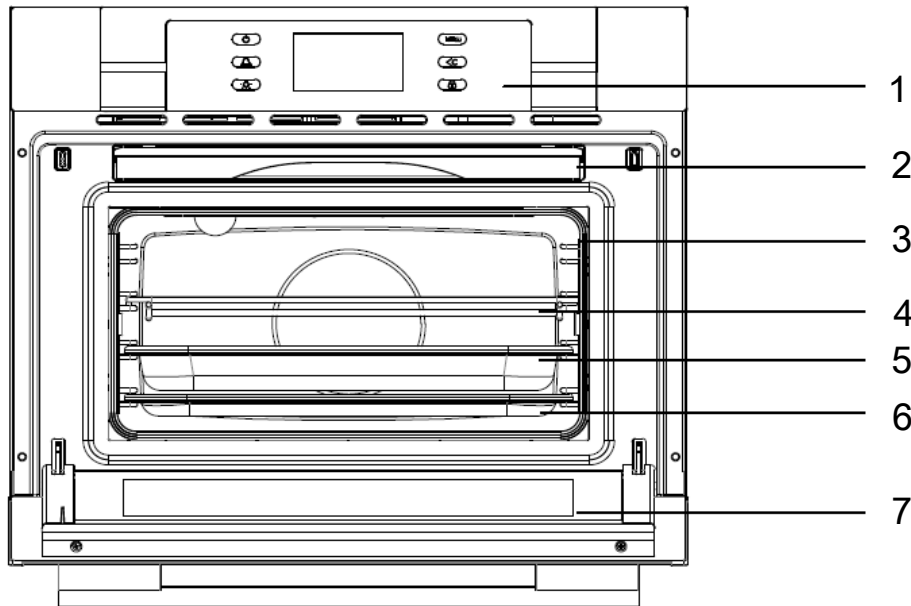

6.1 Product Overview

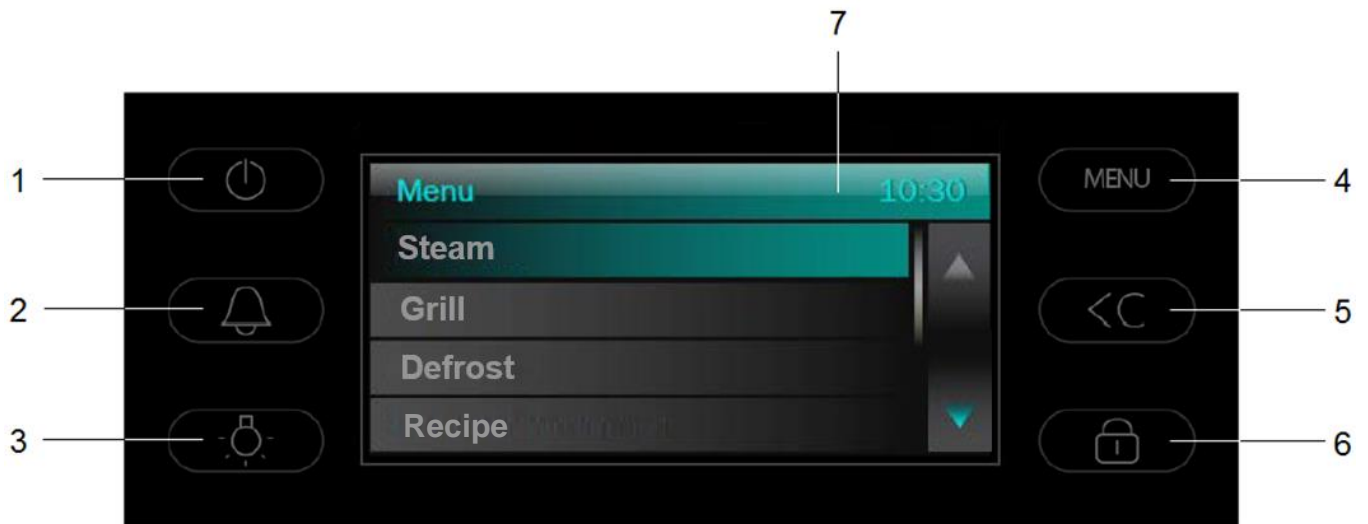

1. Control Panel
2. Water Tank
3. Side Rack
4. Wire Rack
5. Steam Tray
6. Drip Tray
7. Oven Door

6.2 Oven Control Panel



Number	Icon	Descriptions
1		ON / OFF Button, Press button to turn appliance on or off.
2		Buzzer Button, Press button and set the countdown timer for reminder.
3		Light Button, Press button to turn light on or off.
4	MENU	Menu Button, Press button to return to the main menu screen.
5	<C	Return / Cancel Button, Press button to stop the program or back function.
6		Child Lock Button, Press button to lock the display selection.
7		Display Current Selection / Program.

6.3 Display Descriptions

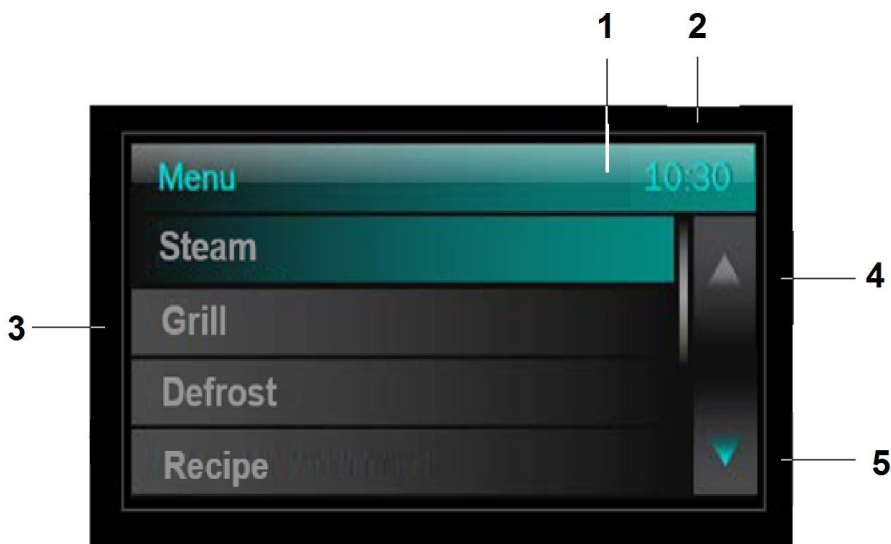

Number	Descriptions
1	Menu
2	Current Time
3	Program Selection
4	Scroll Up
5	Scroll Down





Press  to turn on appliance. The main menu appears in the display with a list of options. Select the program by touching the screen. If the desire program is not appear in display screen, please scroll up or down to search for the programs.

6.4 Main Menu





Program	Temperature
Steam	Default 80°C, from 40°C to 100°C
Grill	Default 180°C, from 50°C to 250°C
Defrost	Defrost only
Recipe	Preset programs with multi program selection
Setting	To set the date, time, language, brightness and others.
Descale	To clean the water tank and oven

6.5 Symbol

The following symbols will be appear in the display screen.

Symbol	Descriptions
	You may scroll up or down by touching ▲ and ▼ button.
	A tick will appear behind the option which is currently selected.
	This indicates additional information is available. This information window will be turned off by selecting OK button.
	The display panel is locked.
	A buzzer reminder has been set.





When a function is selected, the following symbol may appear in the display screen, it depends on program selection.

Symbol	Descriptions
	Heating-up phase
	Cooling phase
	Start time
	Duration
	Finish time

7. PROGRAMS AND FUNCTIONS

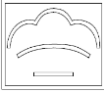
7.1 Selecting the Cooking Programs

To select the cooking programs, turn the knob to desire program. The detail of the programs as below:

Symbol	Function Descriptions
	Steam: To steam the dishes at the maximum 100 °C. The temperature range can be set within the range of 40-100°C. Suitable for steam the vegetable, fish to preserves vitamins and minerals.
	Grill: The top grilling element switches on and off to maintain at certain temperature. The temperature range can be set within the range of 50-250°C. Suitable for grilling small amount of meat and ribs.
	Defrost: The circulation of air at room temperature enables quicker thawing of frozen food (without the use of any heat). It is a gentle but quick way to speed up the defrosting time and thawing of ready-made and cream filled dishes.
	Descal: To clean the water tank and oven. Perform this function at least 6 months and depending on the water hardness selection.

7.2 Setting for the first time

To enter the basic settings for the first time use, in the main menu, scroll down until “Setting” menu.

The list of options will show as follow:

- Date
- Time
- Clock Format
- Language
- Water Hardness
- Brightness
- Buzzer Tone
- Temperature Units
- Factory Default Setting
- Theme

DATE

Click date setting and enter the actual date by touching the keyboard input. The date sequence will display as “YEAR / MONTH / DATE” (YYYY/MM/DD).

Click “OK” to save and return back to setting interface.



TIME

Click time setting and enter the actual time by touching the keyboard input. The time sequence will display as "HOURS : MINUTES" (12:59). The real time display will show on the top right corner.

Click "OK" to save and return back to setting interface.

(If clock format in 12 hours, the maximum for time setting is 12:59, if clock format in 24 hours, the maximum for time setting is 23:59)

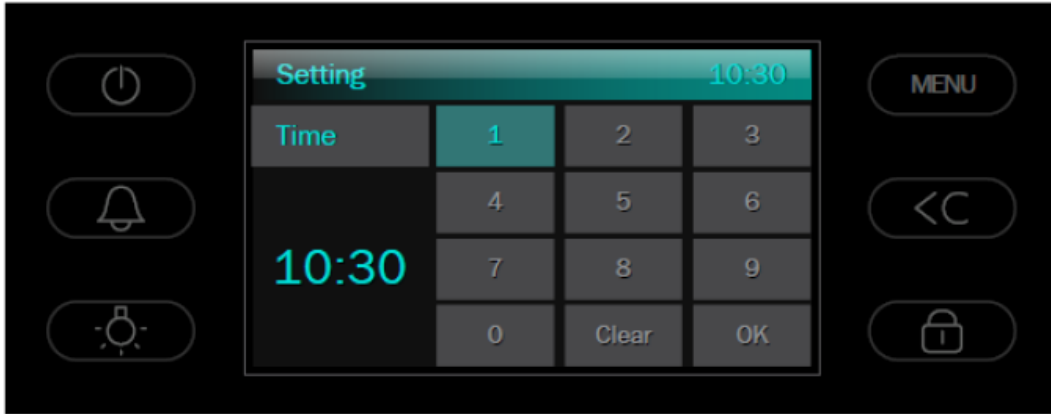

CLOCK FORMAT

Click clock format setting and select the clock format by touching the screen. The clock format selection are 12 hours or 24 hours. Click the desire clock format and your selection will show as "✓" behind the option.

Click "OK" to save and return back to setting interface.

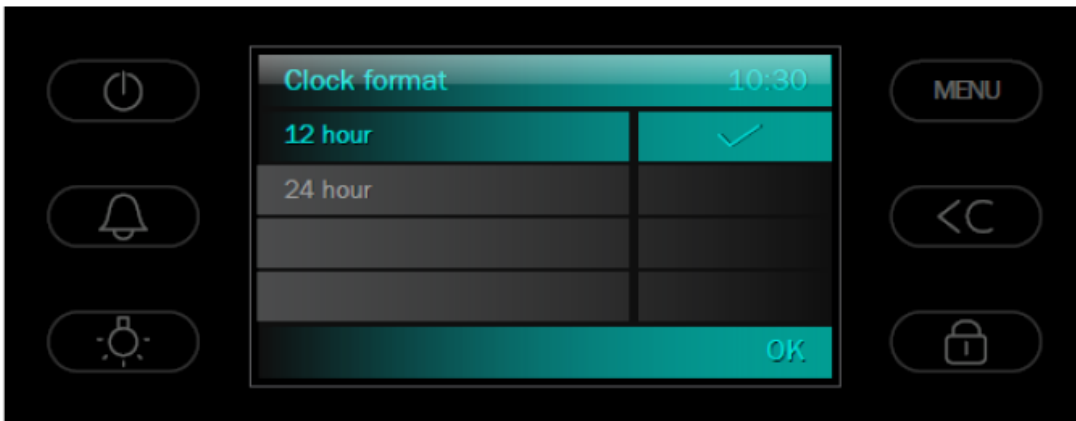

LANGUAGE

Click language setting and select the language by touching the screen. The language selection are Simplified Chinese and English. Click the desire language and your selection will show as "✓" behind the option.

Click "OK" to save and return back to setting interface.

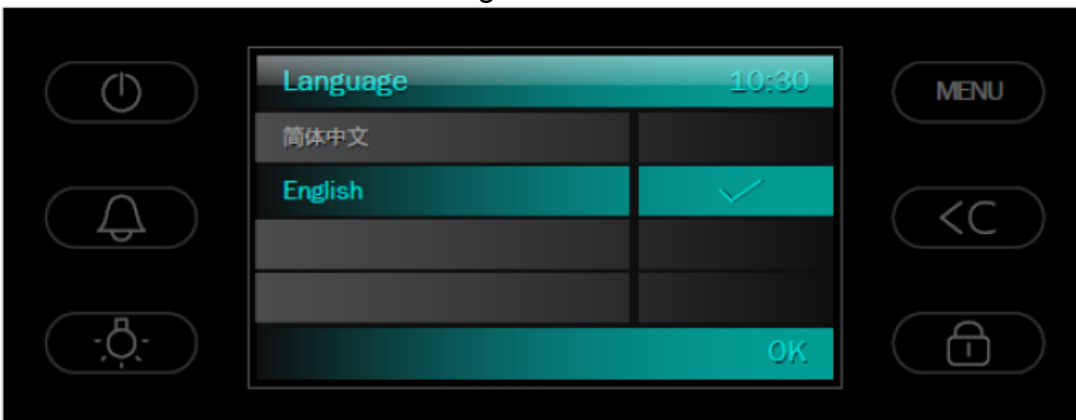

WATER HARDNESS SETTING

Click water hardness setting and select the hardness by touching the screen. The water hardness selection are Soft, Medium and Hard. Click the desire hardness and your selection will show as “√” behind the option.

Click “OK” to save and return back to setting interface.

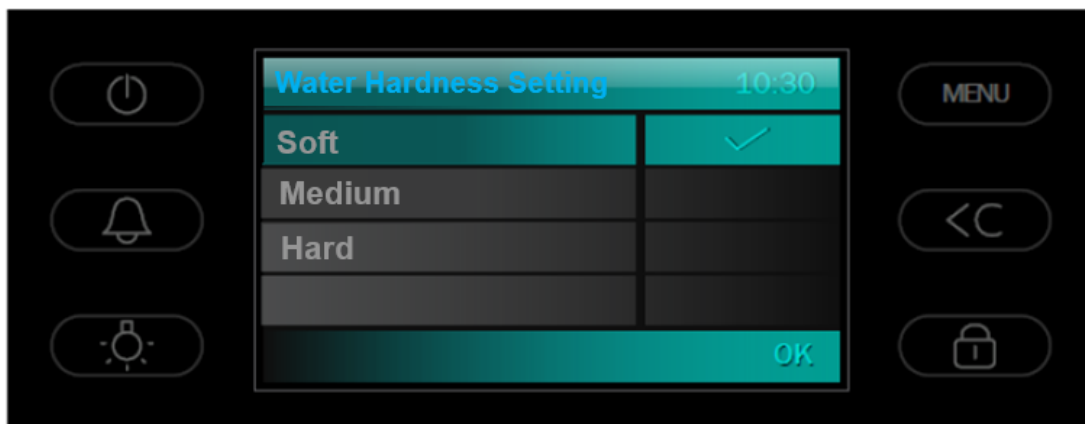

BRIGHTNESS

Click brightness setting and select the brightness by sliding the screen. Slide left to turn the screen brightness to darker and slide right to turn the screen brightness to brighter.

Click “OK” to save and return back to setting interface.



BUZZER TONE

Click buzzer tone setting and select the buzzer toner volume by sliding the screen. Slide left to turn the volume to lower and slide right to turn the volume to higher.

Click “OK” to save and return back to setting interface.



TEMPERATURE UNITS

Click temperature units setting and select the temperature units by touching the screen. The temperature unit selection are °C / °F. Click the desire temperature unit and your selection will show as “√” behind the option.

Click “OK” to save and return back to setting interface.

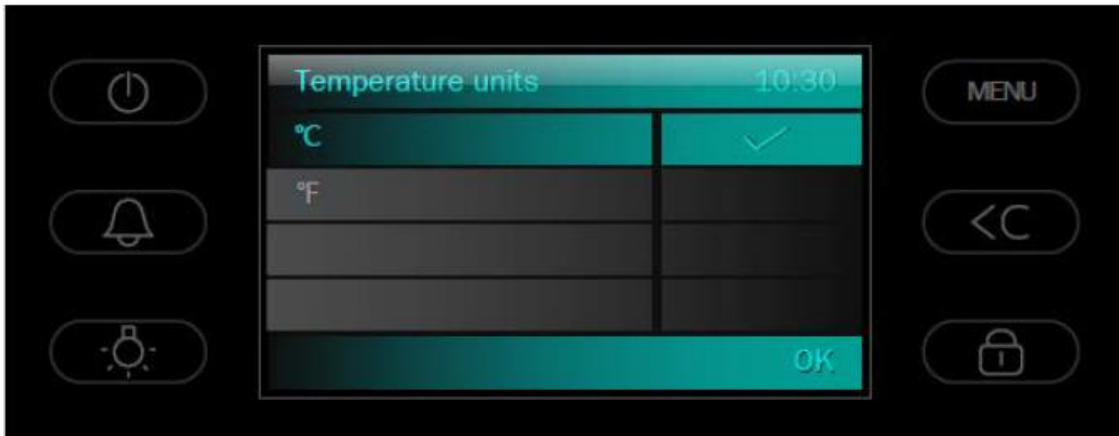

FACTORY DEFAULT SETTING

Click factory default setting if you wish to restore all the setting into default setting. Select the factory default setting and “YES” button will appear. Click “OK” to conduct the restore to default setting.

(Please be remind that all the data entry that previously saved will be deleted)

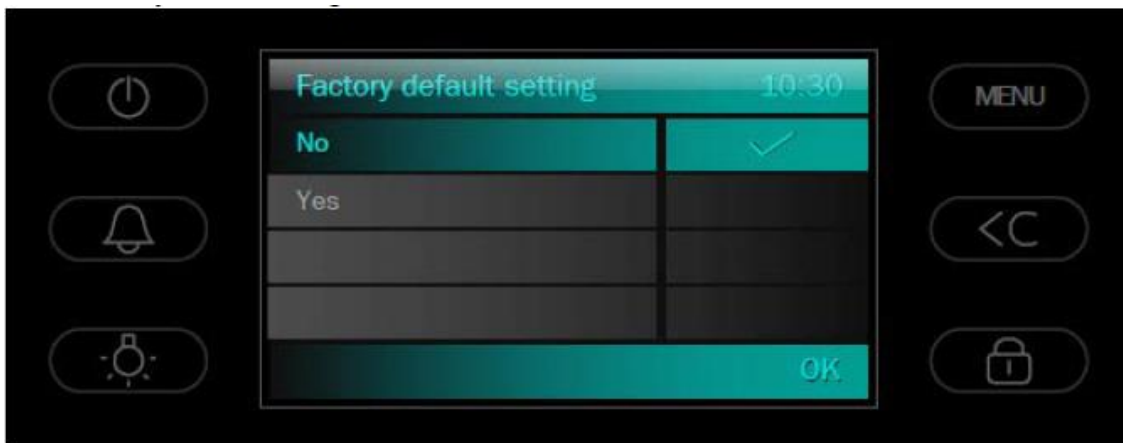

THEME

Click theme setting if you wish to change the theme color. The theme color selection are Orange and Cyan. Click the desire color and your selection will show as “√” behind the option.

Click “OK” to save and return back to setting interface.

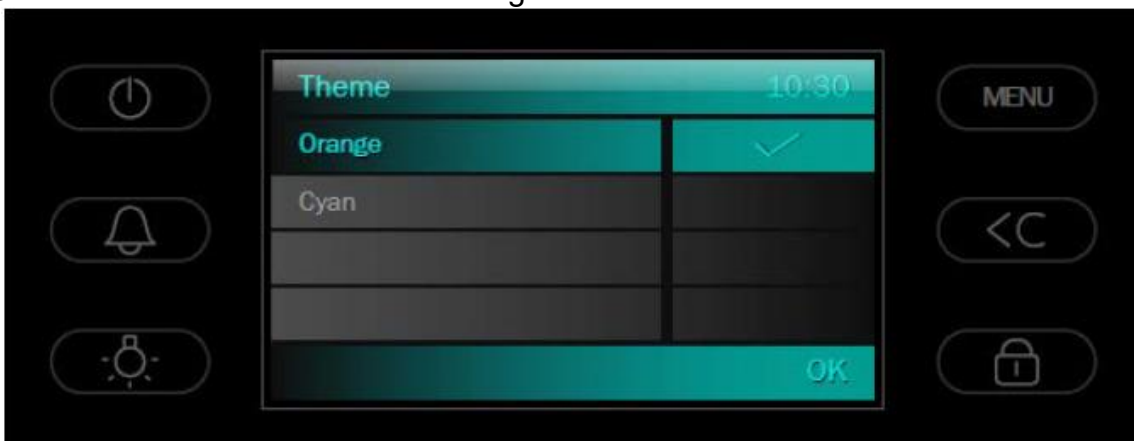

7.3 Oven Operation

Below is the quick overview for the oven operation.

1. Press  to turn on appliance. The main menu appears in the display with a list of options. Select the program by touching the screen. If the desired program is not appear in display screen, please scroll up or down to search for the programs.
2. After the program is selected, the below option will be appear in the display screen.
 - Temperature
 - Duration
 - Start Time
 - Finish Time
 - Heating-up Phase

TEMPERATURE

The temperature default setting is 180°C, the minimum is 50°C / 120°F and up to maximum 250°C / 480°F. The defrost function will be excluded the temperature setting.

Slide left to lower down the temperature and slide right to set the higher temperature. Each slide is about 10°C. You may click the fine adjustment +5°C / -5°C (in °C format), +10°F / -10°F (in °F format).

Click “OK” to save and return back to function interface.

DURATION

Click duration and enter cooking duration by touching the keyboard input. The cooking time duration sequence will display as “HOURS : MINUTES” (02:00). The default duration time will be set as 2 hours. If you wish to change the cooking time duration, just set to the desired time you wish to cook by using the keyboard input.

Click “OK” to save and return back to function interface.

START TIME

Click start time and enter cooking start timer by touching the keyboard input. The start time sequence will display as “HOURS : MINUTES” (04:15). The default start time will remain blank unless user wish to apply it. If you wish to set the start time, just set to the desired time you wish to start by using the keyboard input (For example the current time is 04:10 (12Hours Clock format) and you wish to start the oven after 5 minutes, so just set the time to 04:15. The oven will start operate on the set timer).

Click “OK” to save and return back to function interface.

(If the start time setting is not set, the oven will operate on the current clock time and end on the duration time that previously set).

FINISH TIME

Click finish time and enter cooking end timer by touching the keyboard input. The finish time sequence will display as “HOURS : MINUTES” (06:15). The finish time will base on the duration time unless user wish to extend or shorten the time. If you wish to set the finish time, just set to the desired time you wish to end by using the keyboard input (For example the current time is 04:15 (12Hours Clock format) and you duration has been set for 2 hours. The finish time automatically will become 06:15. If the cooking time is shorter, you may key in the finish timer by using the keyboard input. The oven will end operate on the set timer).

Click “OK” to save and return back to function interface.

(If the start time setting is not set, the oven will operate on the current clock time and end on the duration time that previously set).

HEATING-UP PHASE

Touch the heating-up phase and select the heating-up phase that you wish to apply. The heating-up phase selection are Normal and Fast. Click the desire heating-up phase and your selection will show as “√” behind the option. The default setting for the heating-up phase will be Normal.

Click “OK” to save and return back to function interface.

7.4 Checking the water tank

When the program has began, the system will run for the water tank test first. If the water tank is not in place, the system will show the warning as follow:



Place the water tank in the right position and start the program. If the water tank is in the right position, the water pump will start working. The water pump will pump the water from tank into the boiler. The water level sensor will automatically detect the water level. If the water is insufficient, the system will appear the below message:

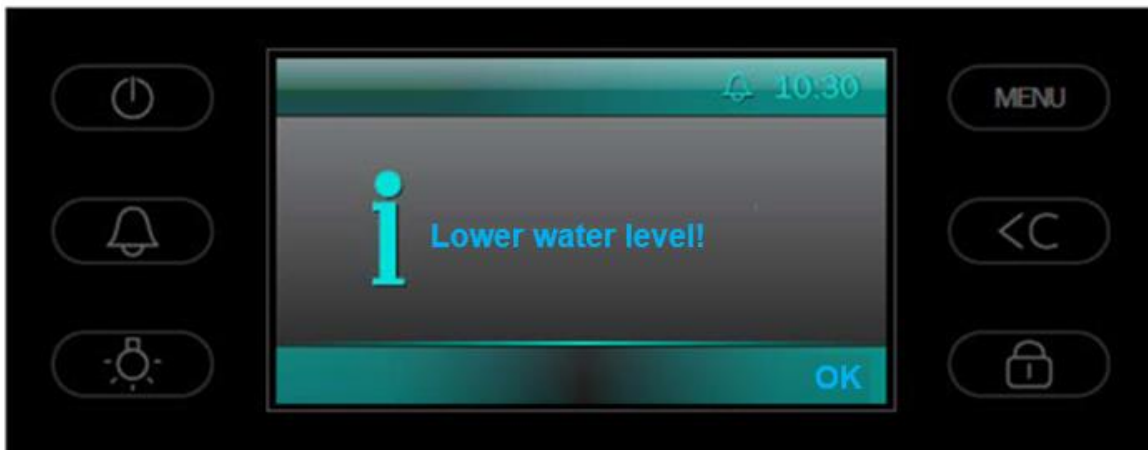

Open the oven door, refill the water tank until it is full and place the water tank in the original place. Then close the oven door and click “OK”. The pump will resume working and pump the water until the water level sensor stop for the in injection. Boiler will start to boil the water.

7.5 End of the program

When the program cycle has ended, the water pump will pump the boiled water back to water tank. In this process, you can touch the "MENU" button and return back to function interface.

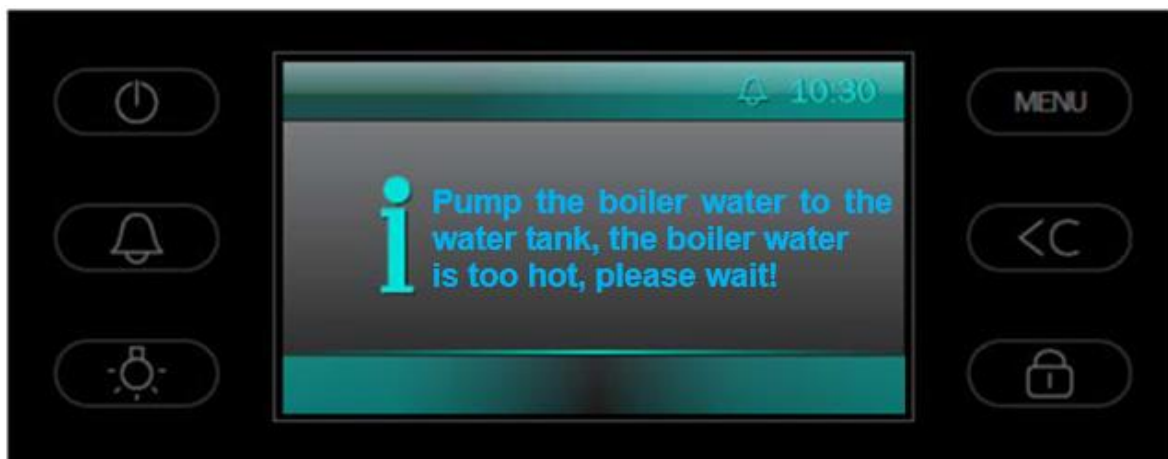

When the temperature falls, the system will automatically operate for the water drainage. The system will back to standby mode after the pumping process

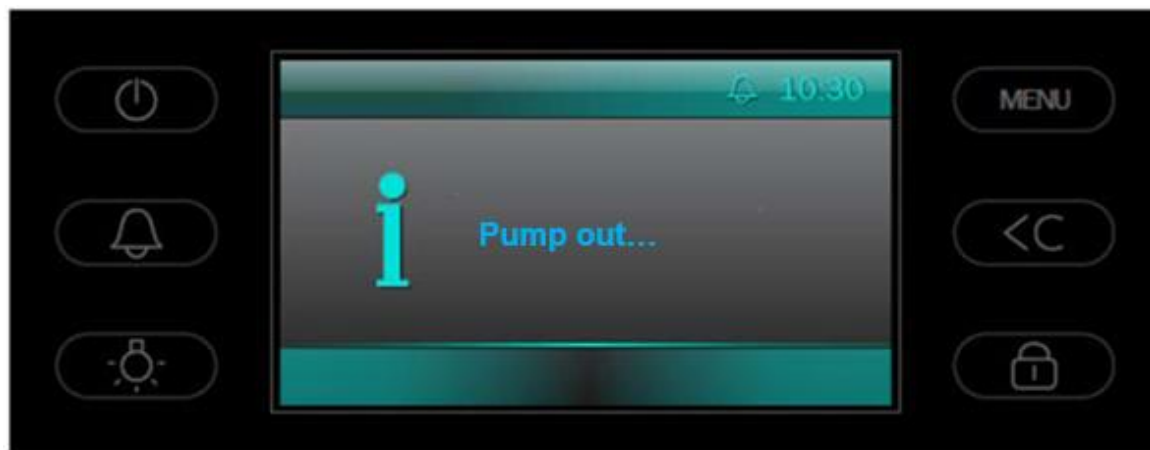

7.6 Change the running program

In the process of program is running, you may click "CHANGE" button to return to the interface of function parameters. You may edit the temperature setting, duration, start time, finish time and heating-up phase. The program will stop temporarily until the latest entry has been enter. Click "OK" to save and continue with the latest program.



7.7 Cancel the running program

In the program is running, you may touch  button to return to the function interface. The display will show the message as below. Touch “YES” to back on the function interface and will terminate the running program. If you wish to continue to running program, touch “NO” to continue.



7.8 Child Lock



- When the oven is in standby mode, touch  and hold for 3 seconds, the control panel will be locked.
- When the oven is in operating mode, touch  and hold for 3 seconds, the current operating interface or function will be locked.
- To release the child lock function, touch  and hold for 3 seconds, the control panel will be back to normal.

7.9 Kitchen Timer (Reminder)

To set the kitchen timer

Touch  and enter to setup interface. Click time setting and enter the timer by touching the keyboard input. The timer sequence will display as “HOURS : MINUTES” (01:00). The timer display will show on the top right corner and countdown began.

Click “OK” to save and return back to menu.

(When the time has been displayed in 00:00, the buzzer will ring and last for 2 minutes. If want to stop the prompt within 2 minutes, touch  and buzzer will stop immediately).

To cancel the kitchen timer

Touch  and enter to setup interface. Set the time to 00:00 and click “OK” and return back to menu. The timer will cancel and timer display will not show anymore.

NOTE: The kitchen timer does not interrupt the cooking process and only a reminder to the user.

7.10 Descaling Function

The descaling cycle is determined by the user setting on the water hardness, the higher of the water hardness, the more frequent of the descaling function is required. Below is the table that shows the frequencies of the descaling.

Water Hardness	Soft	Medium	Hard
Descaling Cycle	18 months	9 months	6 months

Active the descaling function, the system will appear the below message. Click "OK" to start the program. The descaling process will take 45 minutes to complete the full cycle. During the process, all buttons are unable to activate until the cycle is done.

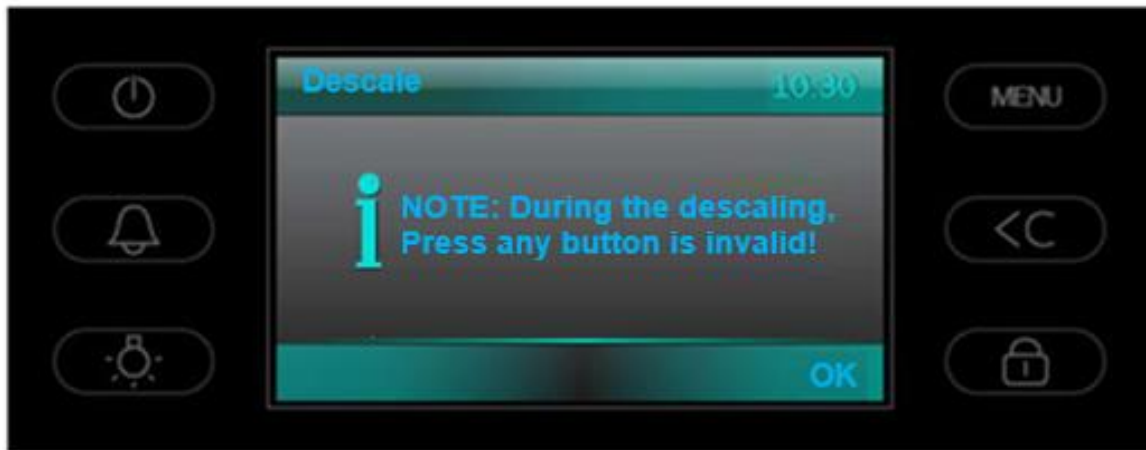

When the descaling function starts, the water in boiler will drain from the boiler and back into water tank and show the message as follows:

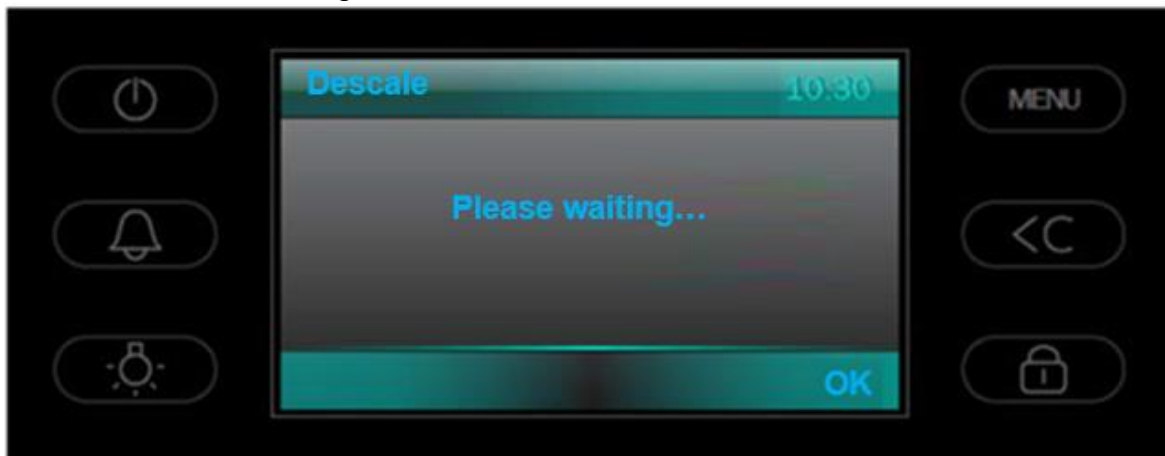

After the water is drained, the system will show the message as follows:

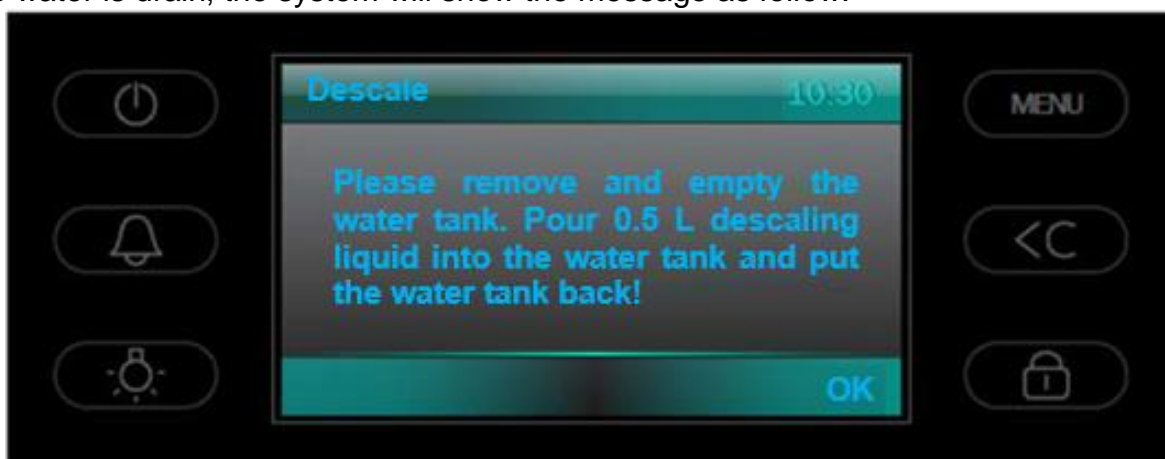

Open the oven door, remove the water tank and pour all the water from water tank until it is empty. Add 500 ml descaling liquid into water tank and insert the water tank back to original position. Then close the door oven and click “OK” to begin the function. The descaling function will start to operate for 45 minutes.

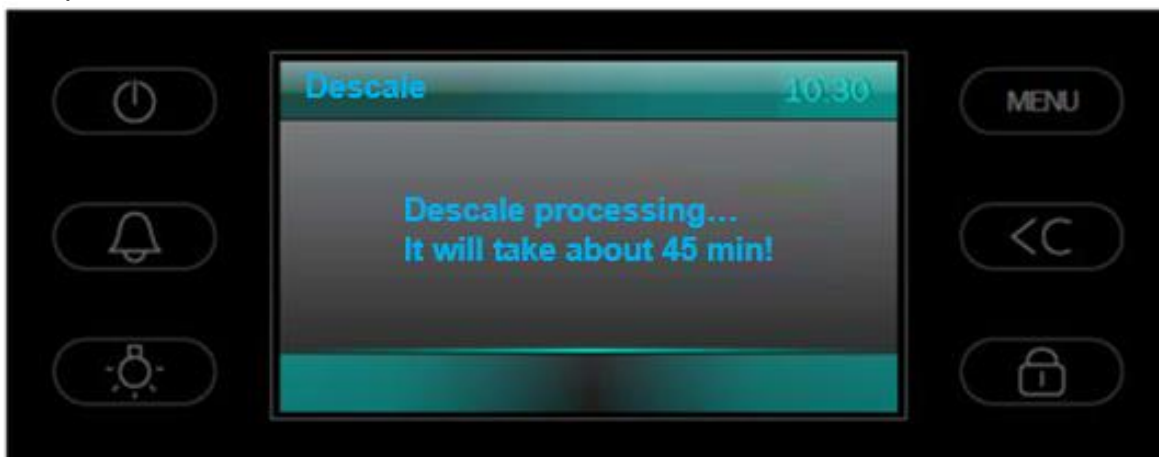

After 45 minutes, the water pump will drain the descaling liquid back to water tank. Open the oven door, remove the water tank and pour the water. Refill 500 ml cold water into water tank and put the water tank into original position.

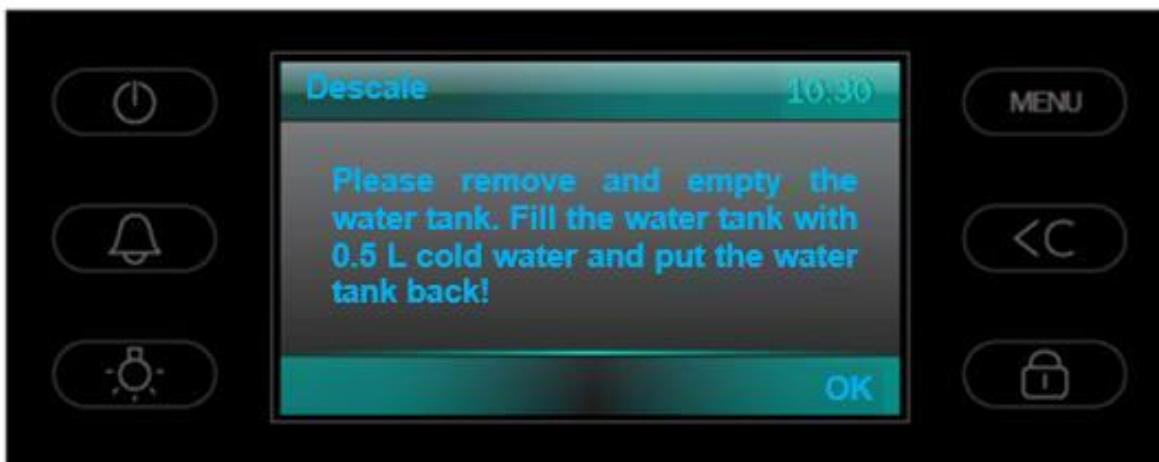

Click “OK” to begin to cleaning process. The system will show the message as below:

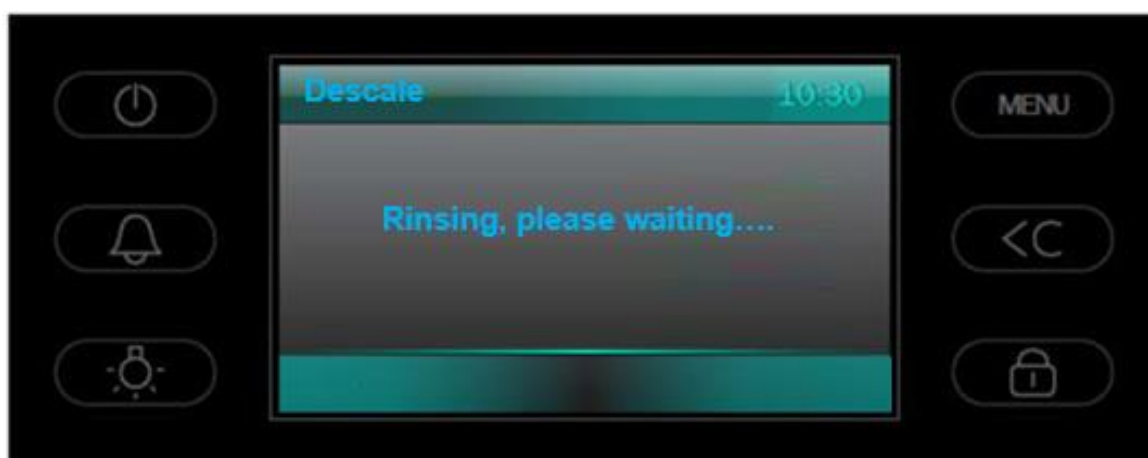

The refill cold water process will repeat for 3 times to complete the cleaning cycle. Please follow the procedure as above to refill the cold water for 3 times.

When the descaling function is complete, open the oven door and remove the water tank. Empty the water tank and ensure the water tank is dry before insert back to original position and ready for next usage.



8. CLEANING AND MAINTENANCE

Before cleaning or performing maintenance on your oven, disconnect the oven from the power supply. To extend the lifespan of your oven, it must be cleaned frequently.

Water Tank

Before using the steam oven for the first time, we suggest to flush the built in water tank. Connect the appliance to power and turn on. Add water and start descaling function. Please empty and flush the built in water tank after every use to avoid having coagulation or odours.

Side Gasket

Use hot soapy water and a sponge and clean and dry the side gasket of the steam oven door every time after use. **DO NOT USE ABRASIVE CLEANING PRODUCTS.**

Inner Cavity of Steam Oven

Clean the inner cavity of the steam oven after using with a soapy sponge or soft cloth to wipe off the residue. Most cooking residue can be removed by cloth with hot soapy water. In some areas where the water supply contains high levels of impurity, it will leave a white deposit in the chamber. Use a soft cloth wetted with vinegar to wipe off this deposit, followed by clean water, wipe and then dry the inner cavity.

Make sure there is no cleaner remain on the side gasket of the steam oven door.

Shelves and Trays

Wash and dry the shelves and trays after use.

Stainless Steel Panel & Casing

Use a soft non abrasive cloth with warm soapy water to the clean control panel, door panel and the casing of the steam oven. Dry the stainless steel surfaces with soft dry cloth. Allowing a stain to stay on the stainless steel surfaces for long periods may damage the stainless steel surface.

WARNING: Do not use harsh chemicals or harsh cleaning agents or use any abrasive material around this area. Doing so may remove these indicator markings which will not be covered by warranty.

General Care

1. Clean the steam oven after it cools down; then dry it thoroughly. Make sure the steam oven interior is completely dry before closing the door.
2. Do not use a steam cleaner on this product. The warranty will not cover the damage caused by the steam cleaner.
3. Do not use any cleaning agent which contains soda, acid or chlorine. Do not use cleaning sprays, harsh abrasive cleaners or sharp metal scrapers to clean the steam oven. Harsh or abrasive cleaners may scratch the stainless steel surface.

Replacing the Oven Lamp

1. Disconnect the oven from the power supply and unplug the oven if the plug is accessible.
2. Remove the glass cover of the lamp holder by turning it counter-clockwise.
3. Turn the bulb counter-clockwise to remove the bulb and replace with a bulb resistant to high temperatures. (300°C).

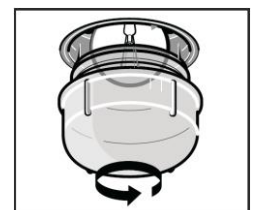

- Replace the glass cover and reconnect the oven to the mains power supply.

Removing the Oven Door

For a thorough cleaning, you can remove the oven door. Proceed as follow:

- Open the oven door to the fullest extends.
- Open the lever A completely on the left and right hinge (Fig.2).
- Hold the door as shown (Fig.3).
- Gently close the door until left and right hinge levers A are hooked to part B of the door and remove the door when part C is fully attached with door (Fig.4).
- Reassemble the door by following the above procedures backwards.

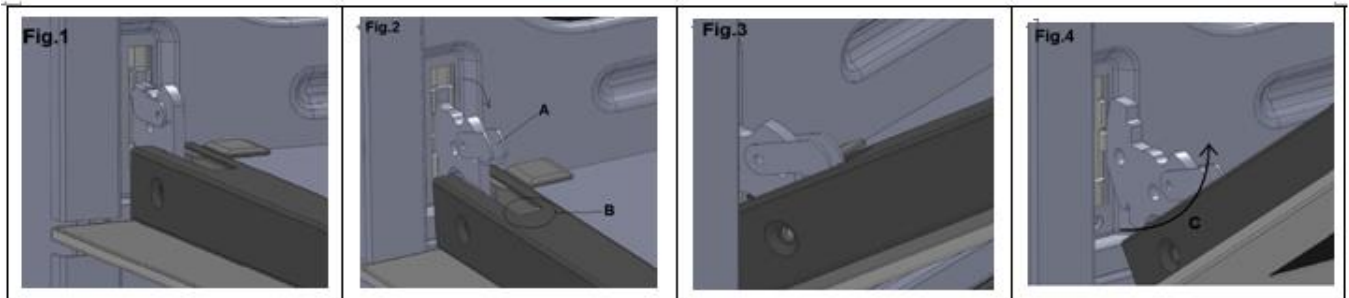

Removing the Inner Glass Door

To remove the inner glass door, proceed as follow:

- Open the glass door and remove cover A by using push the button on left and right sides (Fig.1)
- Gently lift up the cover A and remove it (fig.2)
- Remove the part B and C so that the glass could remove it (fig.3)
- Gently pull out the inner and middle glass for cleaning (fig.4)
- Clean the glass and other components with an appropriate cleaner. Dry thoroughly, and place on a soft surface.
- Reassemble the door by following the above procedures backwards.

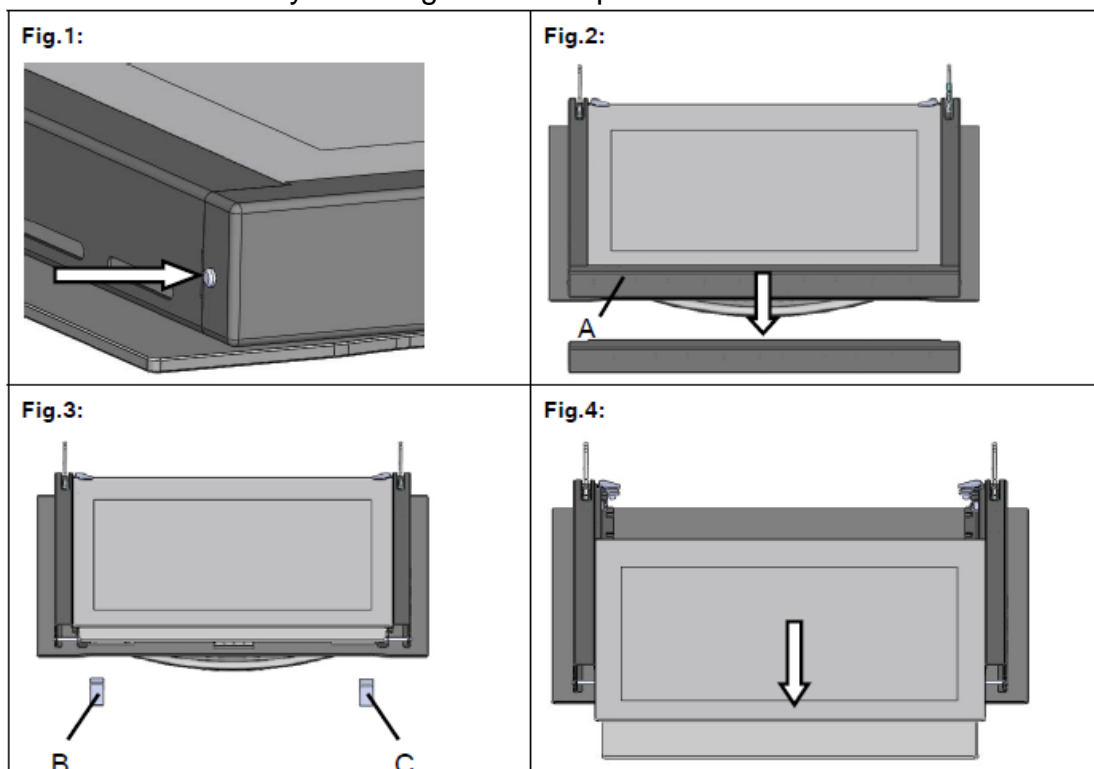

9. TROUBLESHOOTING

Troubles	Reason	Solution
Appliance cannot start up	Door is not closed properly. No power supplied. No water supplied. Function not set.	Check if the door is closed tightly. Check if power plug is inserted well. Check if water level is sufficient. Check if button "On/Off" is pressed.
Heating faulty	Inner Temperature Sensor Malfunction. Pipe is deformed, blocked.	Disconnect the power supply and contact the service center for repair.
Water leakage	Gasket is not function. Water tank leakage. Pipe in the appliance is leakage or spoil.	Disconnect the power supply and contact the service center for repair.

10. TECHNICAL SPECIFICATION

Model	ESGO-H3850TFT(BK)
Capacity	38L
Voltage	220 – 240V
Frequency	50Hz
Power	1,550W
Product Dimension (mm)	594 (W) x 455 (H) x 550 (D)
Built-in Dimension (mm)	565 (W) x 458 (H) x min 600 (D)
Carton Dimension (mm)	657 (W) x 593 (H) x 513 (D)
Gross / Net Weight	33.5 KGS / 29.5 KGS

Notice:

Physical measurement may be different from label because of the products is in continuous improvement. Please refer to physical measurement to make sure definite size.

NOTICE

This product must not be disposed together with domestic waste. It has to be disposed at an authorized place for recycling of electrical and electronic appliances. By collecting and recycling waste, you help to save natural resources and make sure the product is disposed in an environmental friendly and healthy way.



ELBA