



ELBA

**STAND FAN
MODEL: ESF-H1648(BK)**

Owner's Manual

Please read this manual carefully before operating your set. Retain it for future reference. Record model number and serial number of the set. See the label attached on the set and quote this information to your dealer when you require service.

For The Warranty Terms & Conditions, Please Refer To Warranty Certificate.

REMOVE ALL PACKING MATERIALS FROM THIS PRODUCT BEFORE USING IT. THIS APPLIANCE MUST BE INSTALLED ON A FLAT SURFACE. PLEASE ENSURE THE ELECTRIC SUPPLY TO THIS APPLIANCE IS DISCONNECTED BEFORE INSTALLING.

Please read this instruction carefully. It is advisable to keep this instruction manual in a safe place for future reference.

SAFETY PRECAUTIONS

1. Keep electrical appliances out of reach from children. Do not let them operate the appliances without supervision.
2. To protect against the risk of electrical shock, do not immerse the product, cord or plug into water or any other liquid.
3. This product is for household and indoor use only.
4. This product is not intended for use by person (including children) with reduced physical, sensory or mental capabilities unless they have been given supervision or instruction concerning use of the appliance by a person responsible for their safety.
5. If the power cord or plug is damaged, it must be replaced by the service center or a qualified service technician to avoid hazard.

WARNING - to reduce the risk of fire, electrical shock or injury to persons or property, please read and follow below instructions carefully.

- Always operate the product from a power source of the same voltage, frequency and rating as indicated on the product identification marking.
- Do not operate this product if it has malfunctioned, damaged cord or plug or appears damaged in any way. Return the complete product to the place of purchase for inspection, repair or replacement.
- This product should not be used in the immediate vicinity of water, such as bathtub, washbowls, swimming pool etc, where the likelihood of immersion or splashing could occur.
- Always switch off and unplug the plug from outlet when not in use, before assembling or disassembling parts and before cleaning. Fully assemble the fan before operating.
- Avoid contacting with moving parts. Do not insert any object through the guard when the fan is operating.
- Do not cover the guard or operate in close proximity to curtains, etc.
- Always disconnect the fan when moving it from one location to another.

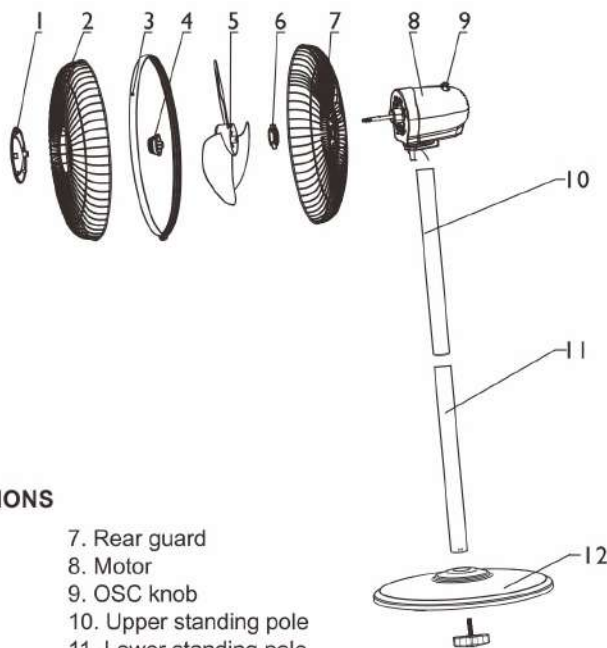

PRODUCT DESCRIPTIONS

- | | |
|----------------|-------------------------|
| 1. Centre ring | 7. Rear guard |
| 2. Front guard | 8. Motor |
| 3. Guard ring | 9. OSC knob |
| 4. Blade knob | 10. Upper standing pole |
| 5. Fan blade | 11. Lower standing pole |
| 6. Guard knob | 12. Base & Screw |

STANDING POLE AND FAN BODY ASSEMBLY

1. Open the gift box and check the parts by referring to the product description drawing.
2. Insert the lower standing pole into the base and fasten the base screw. (Fig. 1)
3. Loosen the thumb screws on the lower standing pole and insert the upper pole into it. (Fig. 2)
4. Put the fan head into the upper standing pole and fasten the thumb screw on the back. (Fig. 3)

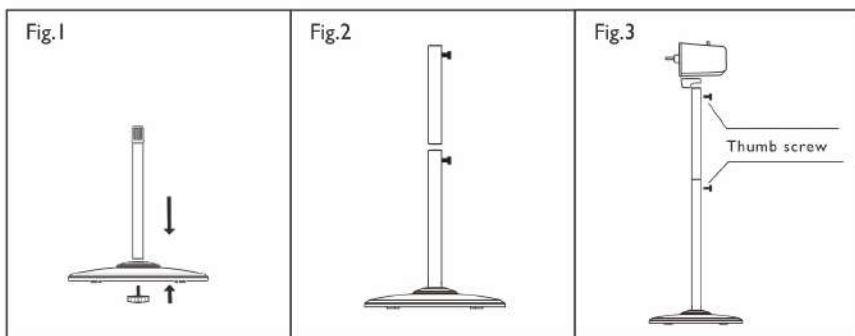

FAN BLADE AND GUARDS ASSEMBLY

1. Remove the blade & guard nut from the motor shaft. Fix the rear guard to the front motor cover, then fasten the guard nut again. (Fig 4)
2. Fix the fan blade to the motor shaft and make sure the shaft pin is fit into groove of the blade. Turn the knob counter-clockwise to fasten the blade. (Fig 5)
3. Fix both fan guards with the guard ring and use a screwdriver to lock the screw. (Fig 6)

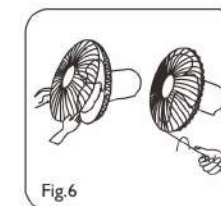
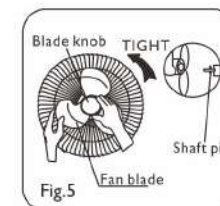
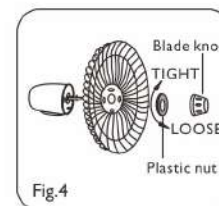

OPERATING INSTRUCTION

1. Speed is controlled by the press button on back of the rear motor cover. The 4 buttons represents "on/off, Low, Mid, High" functions. (Fig.7)
2. To make/stop the fan head oscillate. Press or pull up the OSC knob to control the fan oscillation (Fig.8)
3. The airflow can be adjusted upward or down-ward by pushing or pulling the lower part of the fan guard.

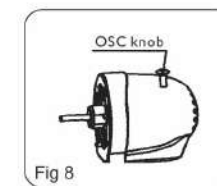
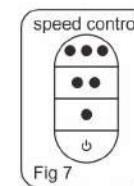

CLEANING AND MAINTENANCE

Clean the appliance with a damp cloth with mild cleaner. Do not use chemical, steel, wooden or abrasive cleaners to clean the appliance.

WARNING: DO NOT IMMERSE THE APPLIANCE INTO WATER. ENSURE THAT THE FAN IS UNPLUGGED FROM THE POWER SUPPLY BEFORE REMOVING THE GUARD.

MAIN SPECIFICATION

MODEL : ESF-H1648(BK)
Voltage : 220-240V/50Hz
Rated Power : 50W
Fan Size : 16-inch
Motor : 3-Speed

NOTICE

This product must not be disposed together with domestic waste. It has to be disposed at an authorized place for recycling of electrical and electronic appliances. By collecting and recycling waste, you help to save natural resources and make sure the product is disposed in an environmental friendly and healthy way.



ELBA