



ELBA

BLENDER **MODEL: EBG-Q1559(GN)** **Owner's Manual**

Please read this manual carefully before operating your set.

Retain it for future reference.

Record model number and serial number of the set.

See the label attached on the set and quote this information to your dealer when you require service.

For The Warranty Terms & Conditions, Please Refer To Warranty Certificate.

IMPORTANT SAFEGUARDS

Before using the appliance, basic precautions should always be followed including the following:

1. Read all instructions before using.
2. Do not operate the appliance with damaged power cord or plug, after the appliance malfunction, or if it is dropped or damaged in any manner. Return the appliance to the nearest authorized dealer or after-sales service center for examination, repair, electrical or mechanical adjustment.
3. Do not use the appliance if the plug, the mains cord or other parts are damaged.
4. Do not let the power cord hang over edge of table or counter or hot surface.
5. Do not place the appliance on or near hot gas or electric burner, or in a heated oven.
6. Do not leave the appliance unattended while operating.
7. Do not touch the cutting edges of the blender blade unit when you clean it. They are very sharp and you could easily cut your fingers on them.
8. Do not operate the appliance for more than 2 minutes continuously at a time. If you have not finished processing after 2 minutes, switch off the appliance and let it cool down before you operate it again.
9. To prevent failure of the appliance, make sure that no food or liquids enter the connection point between the blade unit interface and the motor base.
10. Never reach into the plastic blender with your fingers or an object while the appliance is running.
11. Never use any accessories or parts from other manufacturers or that ELBA does not specifically recommend.
12. Oversized foods or metal utensils must not be inserted into the appliance as they may cause fire or risk of electric shock.
13. If foods stick to the wall of the blender, switch off the appliance and unplug it. Use a spatula to remove the foods from the wall.
14. Always make sure the jar cover is properly closed/assembled on the plastic jar and the lid is inserted properly in the jar cover before you switch on the appliance.
- 15. Never immerse motor base of the blender in water or any other liquids nor rinse it under the tap. Use only a moist cloth to clean the motor base.**
16. Close supervision is necessary when your appliance is being used near children or infirm persons.
17. Always unplug the appliance before you assemble, disassemble or make adjustment to any of the parts.
18. Do not operate the appliance for other than its intended use.
19. Do not use this blender outdoors.
20. This appliance is for domestic use only.
21. This appliance is not intended for use by persons (including children) with reduced physical, sensory or mental capabilities, or lack of experience and knowledge, unless they have been given supervision or instruction concerning use of the appliances by a person responsible for their safety.
22. Children should be supervised to ensure that they do not play with the appliance.
23. Save these instructions for future reference.

PRODUCT DESCRIPTIONS

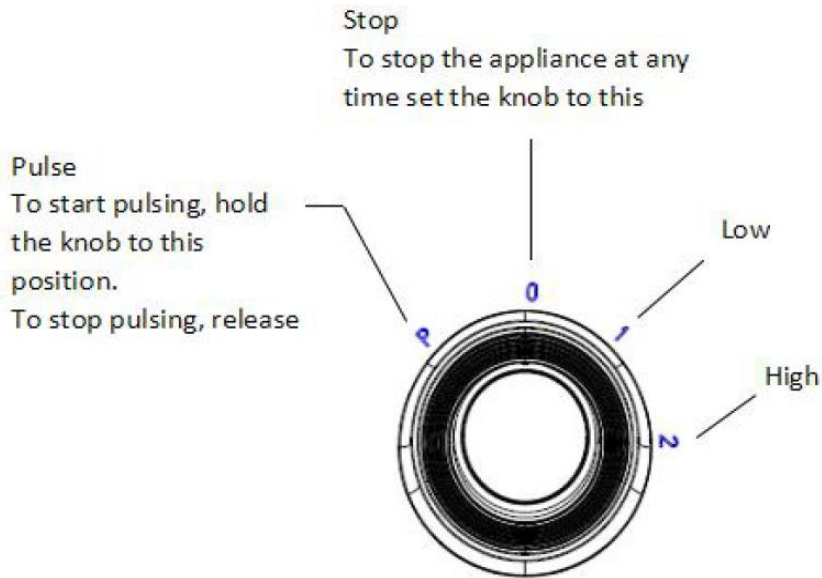
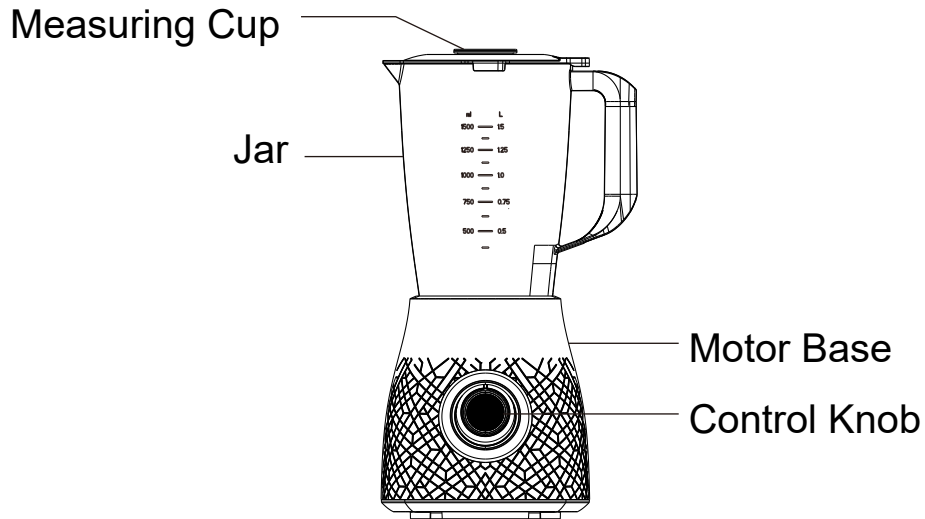

Fig 1

ASSEMBLE AND OPERATING THE APPLIANCE

1. Unpack the appliance and place it on a flat horizontal counter top. Check all the parts whether all in good condition.
2. Clean the removable parts before using.
3. Make sure that the control knob is switched to “0” position. (Fig 1)
4. Put the ingredients into the plastic jar.
5. Mount the measuring cup onto the jar cover. Close the plastic jar with jar cover.
6. Insert the plastic jar onto the motor base and secure it tightly.
7. Power on the appliance and select the desired level of power.
8. Always switch off the appliance by setting the control knob to “0” position before you open the jar cover.
9. Unplug the plug from wall outlet after use.

TIPS FOR BLENDER

- Wash the foods (fruits, vegetable, etc.) that are to be blended (peel the skin or remove pits when necessary). Cut them into pieces to be fit for blending.
- Put the sliced foods into the plastic jar and put on the jar cover and measuring cup.
- Each time of blending, do not put more than half of the cup scale (approximate 0.5 liter) of foods in it. Too small of a quantity is not preferable either. Proper quantity of water should be added into during blending.
- Power on the appliance and adjust the switch to speed “1” (low speed) or speed “2” position (high speed), the blender begins to work. It only takes minutes to blend foods into small pieces. Then adjust the switch to “0” position to turn off the blender, detach the plastic jar and pour out blended foods.
- The blender will also operate when the switch is turn to “Pulse” position. When the switch is loosened, it will return to “0” position and automatic cut off the power. This function is designed for short-time blending (a few seconds), which makes it easy to control the blending results.
- Do not operate the appliance for more than 2 minutes continuously at a time. If you have not finished processing after 2 minutes, switch off the appliance and let it cool down before you operate it again.
- There is a safety interlock device at the bottom of jar, if the jar is not assembled in place, the blender will not operate.

Note: When using the blender with full load capacity or blend for hard fruits and vegetable, ensure to adjust the switch to speed “2” position (high speed). Do not use low speed to blend for full load capacity, it will caused damage on motor due to insufficient torque. When motor speed found too slow, try to adjust to higher speed to blend or adjust the speed to “0” to stop blend.

TIPS FOR GRINDER

- Food (bean, rice, peanut, broad bean and coffee bean etc.) that are to be milled must be sun dried with foreign materials removed.
- Put food into the grinder and lock it onto the motor base. (Fig 2) Do not add in water when grinding.
- Plug the power cord to a power source and adjust the switch to speed “1” or speed “2” position. Thus food can be ground into powder in minutes. Adjust the switch back on “0” position to turn off the unit, then remove the grinder and pour out the food that have been ground.
- The grinder will also operate when the switch is held on “Pulse” position. When the switch is loosened, it will return “0” position and automatic cut off the power. This function is designed for short-time grinding (a few seconds), which makes it easy to control the grinding results.
- Fill the grinder with proper coffee bean, then assemble the grinding blade and grinding bowl together. (Fig.3)
Note: The quantity of coffee bean to grind is Max 50g.
- There is a safety interlock device at the bottom of grinder, if the grinder is not

assembled in place, the grinder will not be operating.

- Disconnect from power supply once finished. Disassemble the grinder attachment from the base, keep the grinding bowl downward and turn it anticlockwise (Fig 4), then empty the bowl and serve.
- Do not run the appliance for more than 30 seconds continuously at a time. If you have not finished processing after 30 seconds, switch off the appliance and let it cool down before you operate it again.

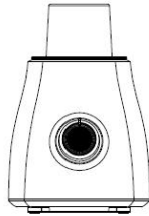

Fig 2



Fig 3



Fig 4

CLEANING AND MAINTENANCE

1. Unplug the appliance.
2. Disassemble all removable parts before cleaning.
Note: Do not rinse the motor base under water tap. Do not use abrasive cleaning agents, sources, etc. to clean the motor base!
3. When cleaning the plastic jar, be careful of the blades as it is very sharp.
4. Clean the motor base with a moist cloth.
5. Clean the removable parts immediately after use.

SPECIFICATIONS

1. Voltage : 220-240V~, 50-60Hz
2. Power : 500W
3. Short time operation: each operation time cannot exceed 2 minutes, and stop for 2 minutes. Stop for 30 minutes after every 5 operations.

ENVIRONMENT-FRIENDLY DISPOSAL



You can help to protect the environment!

Please remember to respect the local regulations: hand in the non-working electrical equipment to an appropriate waste disposal center.

ELBA