



MADE IN THE USA

INSTALLATION MANUAL

TJ & LJ STEP SLIDER 2 DOOR

1997-2006

BD-SS-100-TJ

BD-SS-100-LJ



Step Sliders for TJ & LJ Jeeps

Parts & Tools

Description	Quantity
Electric Step Slider (Pair)	2
Wiring harness	1
Double sided adhesive strips	4
Door sensor	4
Magnets	4
Alcohol wipes	4
Rocker cutoff switch	1
5/16-18" Knurled Nutsert	12
5/16 x 1 1/2 Stainless Steel Fender Washer	8
5/16-18 Nutsert	8
5/16 x 1-1/2" Grade 5 Tap Bolt	8
5/16 x 1" Stainless Steel Button Head Bolt	12
5/16 x 3/4" Stainless Steel Flat Washer	12
1/2" Aluminum Spacer	4
Anti-Seize Packet	1

Tools Required

Nutsert Tool	Drill
3/16 Allen Wrench	5/32 & 1/2 in. Drill Bit
1/2 Wrench or Socket	

Notes and Maintenance

Before you begin installation, read all instructions thoroughly.

Proper tools will improve the quality of installation and reduce the time required.

No maintenance required on waterproof harness or water-resistant motors.

If mud or dirt is built up on the steps, simply spray them off and let them air dry.

Mild automotive detergent may be used to clean the product. Do not use dish detergent, abrasive cleaners, abrasive pads, wire brushes or other similar products that may damage the finish.

Periodic inspection of all wires and connections should be performed to ensure there is no visible damage or loose connections.

Refer to the last page of this manual for troubleshooting, warranty and product registration information.

Harness Layout

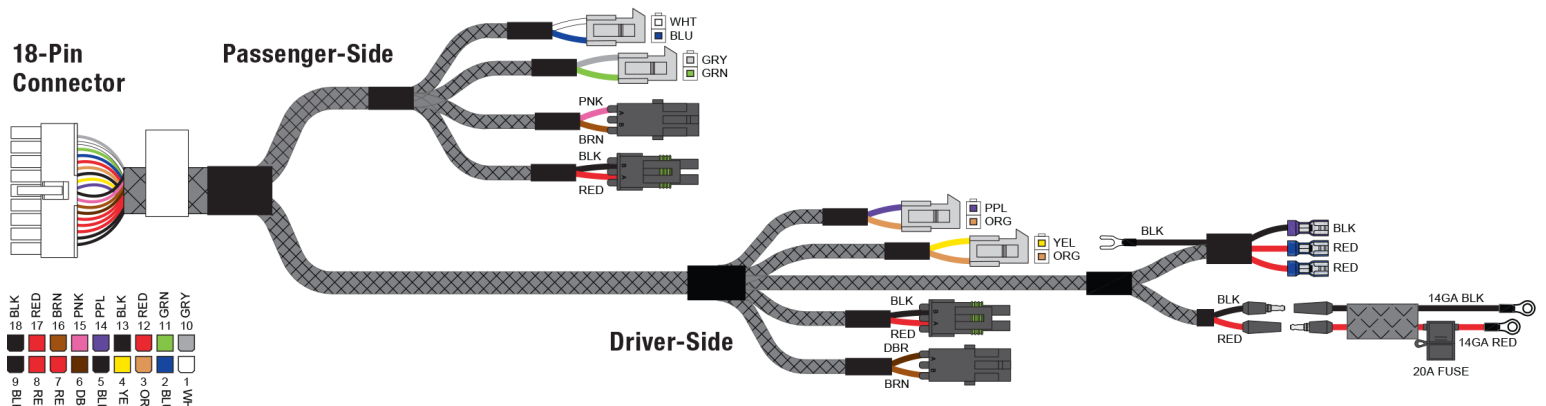

Harness Diagram - 1

- A. CIRCUIT BOARD CONNECTOR**
- B. EXTRA DOOR SENSOR - DO NOT USE**
- C. FRONT DOOR SENSOR CONNECTOR**
- D. MOTOR CONNECTOR**
- E. LED LIGHT CONNECTOR**
- F. ROCKER SWITCH GROUND**
- G. ROCKER SWITCH CONNECTORS**
- H. BATTERY HARNESS CONNECTORS**
- I. FUSE HOLDER**
- J. BATTERY TERMINALS**
- K. EXTRA DOOR SENSOR - DO NOT USE**
- L. FRONT DOOR SENSOR CONNECTOR**
- M. LED LIGHT CONNECTOR**
- N. MOTOR CONNECTOR**

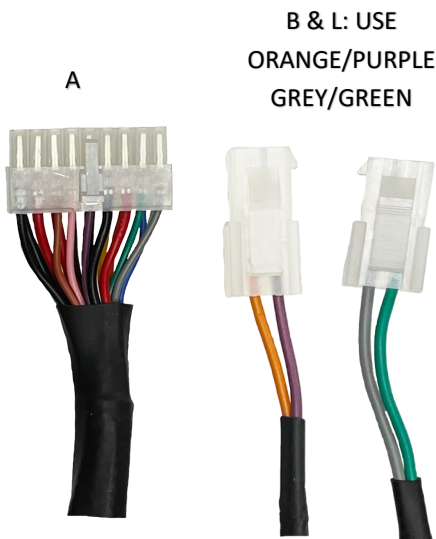
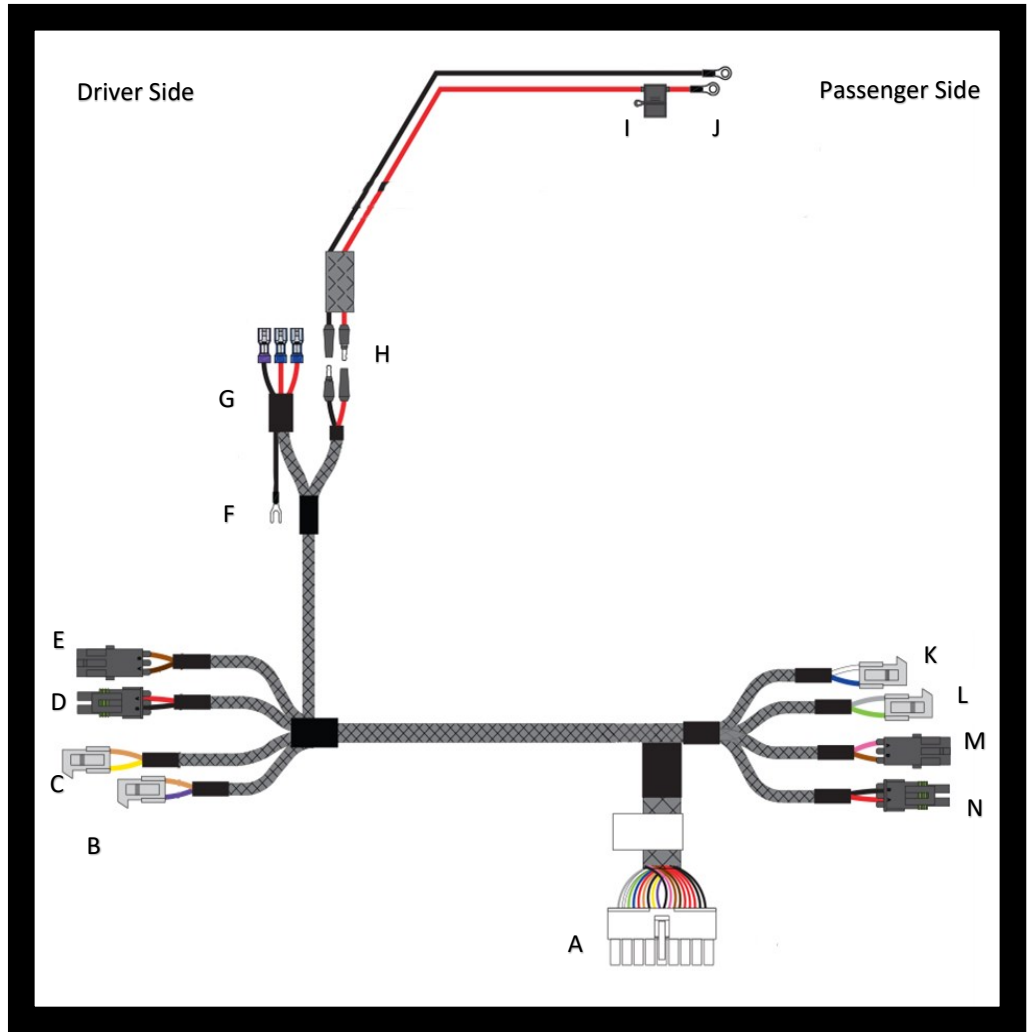

**C & K: DO NOT USE
ORANGE/YELLOW
BLUE/GREY**

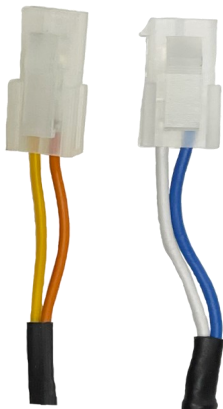

D & N



**E & M:
BROWN/TAN
PINK/TAN**

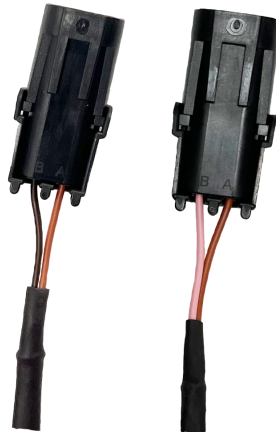

F



J



Step 1

Remove your stock sliders from the Jeep. Once they are removed, begin by lifting the step slider to the side panel. You will mark where you will need to drill your bolt holes with a marker on the side panel and on the tub.

TJ - 5 side panel holes.

LJ - 6 side panel holes.

Both models - 4 tub holes.

IMPORTANT

Secure the Step Slider tight to the underside and against the side panel. Take time to ensure you are installing the slider straight and at the right level.

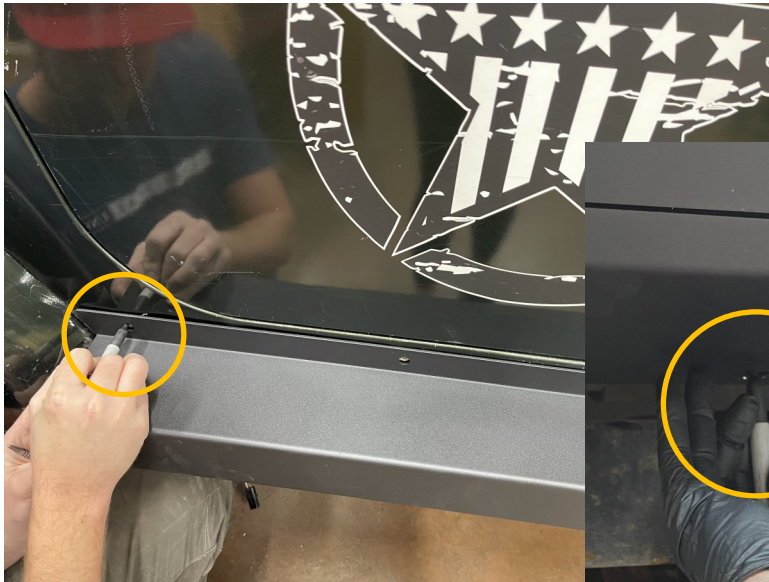

Step 2

SIDE PANNEL DRILLING

Lower the Step Slider carefully. Drill a 5/32 hole into the side panel. Drill that same hole out with your 1/2 inch drill bit. Do a test fit with your knurled nutsert for the body.

IMPORTANT

If you need to remove additional metal for the nutsert to be installed, remove the necessary material using a Dremel or Air tool. The nutsert should fit snug into the hole.

TUB DRILLING

Drill a 5/32 hole into the tub. Drill that same hole out with your 1/2 inch drill bit. Do a test fit with your military style nutsert.

Step 3

Once your holes are drilled and test fits are done, use a nutsert tool to crush the nutserts into place.

Knurled Nutsert - Side Panel.

Military Nutsert - Tub.

SECURING YOUR STEPS

Lift the step to even match up to the bolt hole and your installed nutsert. Using the 5/16" button head bolts and small washers, secure the step to the side panel.

Underneath the step, use the tap bolts and fender washers to secure the step to the tub. Begin by taking the 1/2 inch spacer and placing it between the step and the tub, lined up with the bolt holes. Then, begin to secure the step to the tub. Hand tighten each of the bolts first, then torque to 18 ft. lbs.



IMPORTANT

Coat your bolts using the anti-seize packet. Start each of the bolts to hold it into place before tightening all of them completely.



D & N



IMPORTANT

Plug in your motor connectors before tightening the step completely for ease of access. LED lights can be installed after step installation is complete.

Step 4

REMOVE THE FUSE FROM THE HARNESS

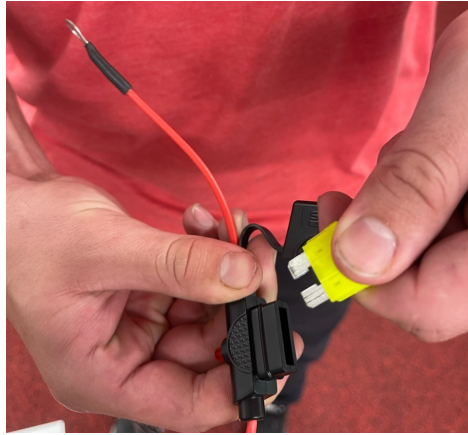
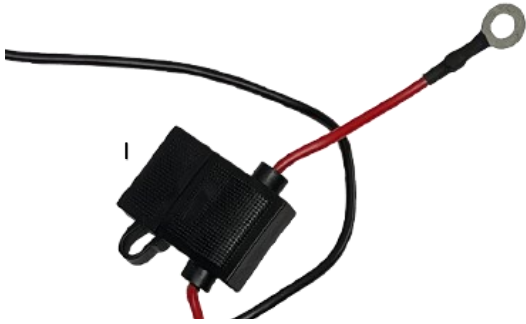

INSTALLING THE DRIVER SIDE OF THE HARNESS

Once the fuse is removed: remove the floor mats and rocker guards. Attach the battery terminals, red wire (+) and black wire (-) to the battery.

Rout the harness across the engine bay. Pop the firewall plug out that has two ridges on it by applying pressure from the inside. Drill a hole through the plug large enough to run both wiring harness ends through.

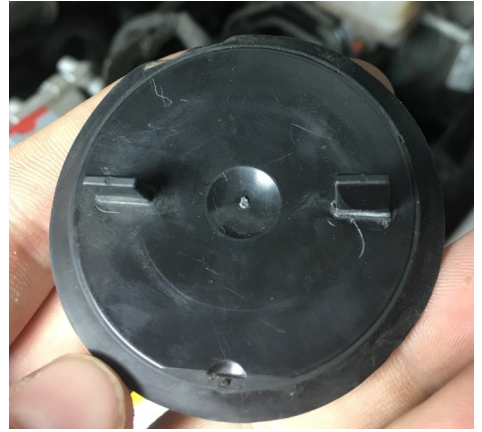

Secure the wiring into place using zip ties.

IMPORTANT

At the end of the install, fill the plug hole with silicone to prevent leaking.



Step 5

Remove the rocker panels. Unravel the large harness in the rear seat and route the connectors to the front of the vehicle under the removed panels. Follow the harness diagram on pg. 4.



Step 6

Remove the floor plugs under the seats. Drop the motor connector (D & N) through the open holes.

IMPORTANT

If you are installing the optional light kit, you will want to run the light connectors (E & M) through the drain plug as well. If not, keep inside the cab for later installation.

Run the harness under the carpet in front of the rear seat. You will continue to run the circuit board connector (A) under the carpet, up underneath the back seat. This will hide the circuit board and harness.

* Do not place the circuit board or harness near the front passenger seat if you have a tumble seat. You will risk crushing the circuit board or damaging the harness.

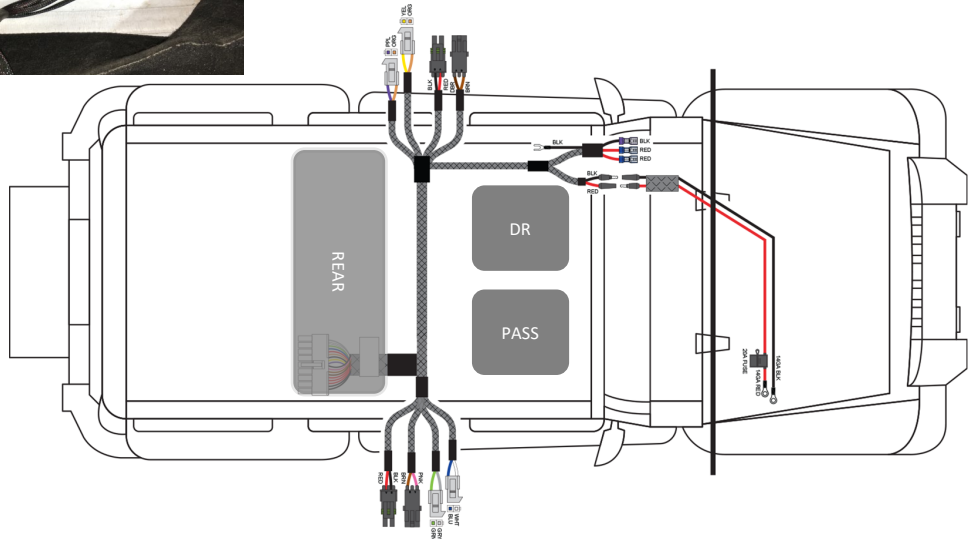

Step 7

INSTALLING DOOR SENSORS

Using alcohol wipes, clean the area directly below the door striker. Making sure the surface area is clean and ready for the door sensor adhesives.

With the door sensor in hand, use the double sided adhesive and attach it to the back of the sensor.

Press the sensor firmly below the door striker. Expose the adhesive on the foam wire protector next to the sensors and wrap the foam around the frame metal. Connect the door sensor to connectors (B & L).

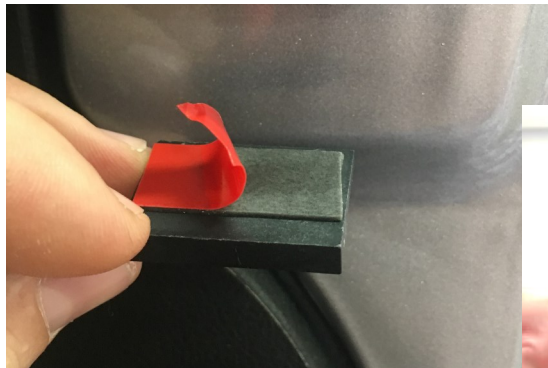

Step 8

INSTALLING MAGNETS

Using the alcohol pad, clean the metal on the inside of the door. Peel of the backing to secure the magnet to the adhesive pad and firmly press the magnet into place.

The magnet location is on the outer part of the door. Opposite where the sensors are placed below the door striker. Roughly 1/4 in. down from the bottom screw below the door latch.

IMPORTANT

Do a test fit to make sure the magnet is properly aligned with the door sensors.



Step 9

ROCKER SWITCH INSTALLATION

Drill a 3/4 in. hole in the dash to accommodate the switch. Run the wires through the hole and connect the blue female connector into the silver male ends and the red female connector into the bronze male end.



Mount the ground wire from the plug to a metal surface for illumination. Be sure you have good metal to metal contact for that connection.



Step 10

Once all of the harness is installed, secure the battery harness and main harness together (H).

Connect the circuit board in the back.



Step 11

CALABRATION CYCLE

With both of your step sliders installed, it is time to let the circuit board calibrate.

Close both doors. Reinstall the fuse. When you do this, the steps will deploy and retract once. This indicates your steps are functioning correctly.

YOU ARE DONE!

Scan this code to leave us a review.



See our FAQ on the next page for any troubleshooting or give us a call!



IMPORTANT

Make sure there is nothing that will stop the step from deploying and retracting fully. If something has blocked your step, remove the fuse again and re-run the calibration cycle.



FREQUENTLY ASKED QUESTIONS:

<p>I just installed my steps and they are not coming down when I open the door.</p>	<p>Double check the connections. Check the fuse to make sure it is plugged in. Is the on / off switch getting power? Is the circuit board plugged in? Are the door sensors plugged in?</p>
<p>My rocker switch is getting power, but the light stays on in both positions.</p>	<p>The light is only supposed to be on when the system is turned on. If it is lit in both positions simply switch the red wires on the back. Will this kill my battery with the light constantly lit? This will not kill your battery unless you leave it lit for a month with no use.</p>
<p>Everything is plugged in and the switch is turning on and off, but the steps still won't deploy.</p>	<p>Check the motor first. Simply unplug it from the wiring harness and apply external 12V power to the leads. One position will make them deploy. Switch the leads again to make them retract. If this works, plug the motor back into the harness. We test each and every motor that leaves our factory by hand along with assembling your step slider by hand. These may fail, but it is extremely rare after we send them after having tested them. If you test the motor and all you hear is a clicking sound but nothing happens, there is likely internal damage.</p>
<p>I tested the motor, and it works. I checked the sensors individually, and the system still won't work. The steps don't deploy unless I do it manually with 12V power.</p>	<p>In rare circumstances, the circuit board that runs the system may be faulty. Send us an email at Warranty@rockslideengineering.com to request a new circuit board.</p>
<p>I opened my door a bunch of times and the system just shut off. What happened?</p>	<p>Our systems have built-in protection against quick cycling like this to prevent damage. Simply turn your on / off switch to off, wait 5 seconds, and then turn it on again. This will reset the system and allow it to work normally again.</p>
<p>Everything is working now. But I want to take my doors off and have the steps still work.</p>	<p>We sell a door delete kit you can replace those sensors with. Part# SL-DD-100 comes with everything you need for two doors. If you want to install a delete kit on the rear doors as well, you will need to purchase two kits.</p>
<p>The steps deployed and won't retract. What is going on?</p>	<p>Chances are your magnets are misaligned. To diagnose which door needs to be adjusted, unplug the rear sensors with the front doors closed. If your steps come up, then it was the rear doors that need to be aligned with your magnet. If the step stays down, the front door needs to be aligned. Open your door, shift the magnet in a direction, and shut it again. Repeat until the step comes up when the door is shut. Mark the magnet placement on the front door. Plug the rear door sensor in, shut the rear door and front door, and see if it comes up. If not, the rear door is misaligned (Since we just aligned the front door we know it's the rear door now). Repeat the previous process of opening your door, shifting your magnet, and shutting your door until the step comes up. It may take a few tries.</p> <p>OPTION 2</p> <p>Check the sensors. Unplug both of them from the wiring harness on the side that is not working, and plug one back in. Manually test your sensors by putting a magnet really close (but not touching) to the sensor. Does it make the step retract? When the magnet is away, the step should deploy. If the steps deploy right after installation, more than likely your magnets just need to be aligned. Do this one by one with each sensor by the method above. Install one sensor, test, align the magnet on the door, test, and then mark the position of the magnet so if for some reason they do move out of place you can easily realign them.</p>
<p>I was off-roading, left my system on, someone left the door ajar and I ripped my step off on a rock. What now?</p>	<p>We can replace these parts for you at cost. You will have to remove the step off your vehicle to replace the innards. Call us and we'll figure out what you need exactly! If you prefer us to do the repair we will do that for you! You will have to cover shipping to us and the cost of the parts, but we will ship it back to you (from our warehouse to your house) on our account.</p>

WARRANTY POLICY

LIMITED TWELVE (12) MONTH WARRANTY FOR FINISH AND ELECTRICAL COMPONENTS

Rock-Slide Engineering, LLC (“RSE”) warrants to the original purchaser that (a) the structural and mechanical components of the Step Sliders will be free of defects in material and workmanship for the lifetime of the Step Sliders (the “product”), and (b) the finish (powder coat) and the electrical components (including the motor) will be free of defects in material and workmanship for a period of twelve (12) months from the original date of purchase. This warranty applies only to the original retail purchaser. Warranty is void if product was not purchased directly from R- SE or from an authorized RSE retailer or reseller. This warranty applies only with regard to the product as originally installed to the original vehicle. This warranty does not cover removal or reinstallation of the product.

To exercise this warranty and receive any warranty service, the original purchaser must provide RSE with proof of purchase and date of purchase that is acceptable to RSE, such as a copy of the original purchaser’s purchase receipt. The original purchaser must return the defective product to RSE along with a description of the problem, a copy of the original purchase receipt, the original bill of sale and all contact information (name, address, telephone number and email address). To begin the warranty process, the original purchaser must email RSE’s warranty department. During this warranty term, and upon the original purchaser’s valid exercise of this warranty, RSE shall, at its option, repair or furnish the replacement product in the event the original product is deemed by RSE to be defective. RSE’s sole liability shall be for repairing or replacing the product, but RSE may refund the purchase price at its sole discretion and option. The original purchaser is responsible for prepayment of all shipping and/or transportation charges with respect to the exercise of this warranty. The product may change without notice. In the event of a product change, RSE has no obligation to upgrade or modify any older generation product.

THE WARRANTY SET FORTH HEREIN IS THE ONLY WARRANTY COVERING THE PRODUCT. NO OTHER WARRANTY EXISTS, EXPRESS OR IMPLIED, INCLUDING, WITHOUT LIMITATION, IMPLIED WARRANTIES OF MERCHANTABILITY AND/OR FITNESS FOR A PARTICULAR PURPOSE. No retailer, reseller, dealer, agent, or employee is authorized to make any modifications, extensions, amendments, or additions to this warranty.

This warranty shall be void in its entirety if RSE determines that the product installation was modified, changed, altered, customized or in any way used other than as instructed. Installation of the product without strictly adhering to the installation instructions shall void this warranty. Installation must be on the proper vehicle or warranty is void.

RSE SHALL NOT BE LIABLE FOR SPECIAL, INDIRECT, INCIDENTAL OR CONSEQUENTIAL DAMAGES, UNDER ANY LEGAL THEORY AND/OR UNDER ANY CIRCUMSTANCE WHATSOEVER. IN ANY EVENT, ANY DAMAGES IN ANY SITUATION SHALL BE LIQUIDATED DAMAGES AND MAY NOT EXCEED THE RETAIL PRICE OF THE PRODUCT. RSE SHALL NOT BE LIABLE FOR ANY LOSS, DAMAGE OR INJURY DIRECTLY OR INDIRECTLY ARISING FROM THE USE OF OR INABILITY TO DETERMINE THE USE OF THE PRODUCT. THE ORIGINAL PURCHASER IS RESPONSIBLE TO DETERMINE THE SUITABILITY OF THE PRODUCT FOR ITS INTENDED USE, PRIOR TO USING THE PRODUCT, AND THE ORIGINAL PURCHASER ASSUMES ALL RESPONSIBILITY AND RISK IN CONNECTION THEREWITH.

For questions or concerns: please contact our office at 435-752-4580 and ask for the warranty department or email us at warranty@rockslideengineering.com.