

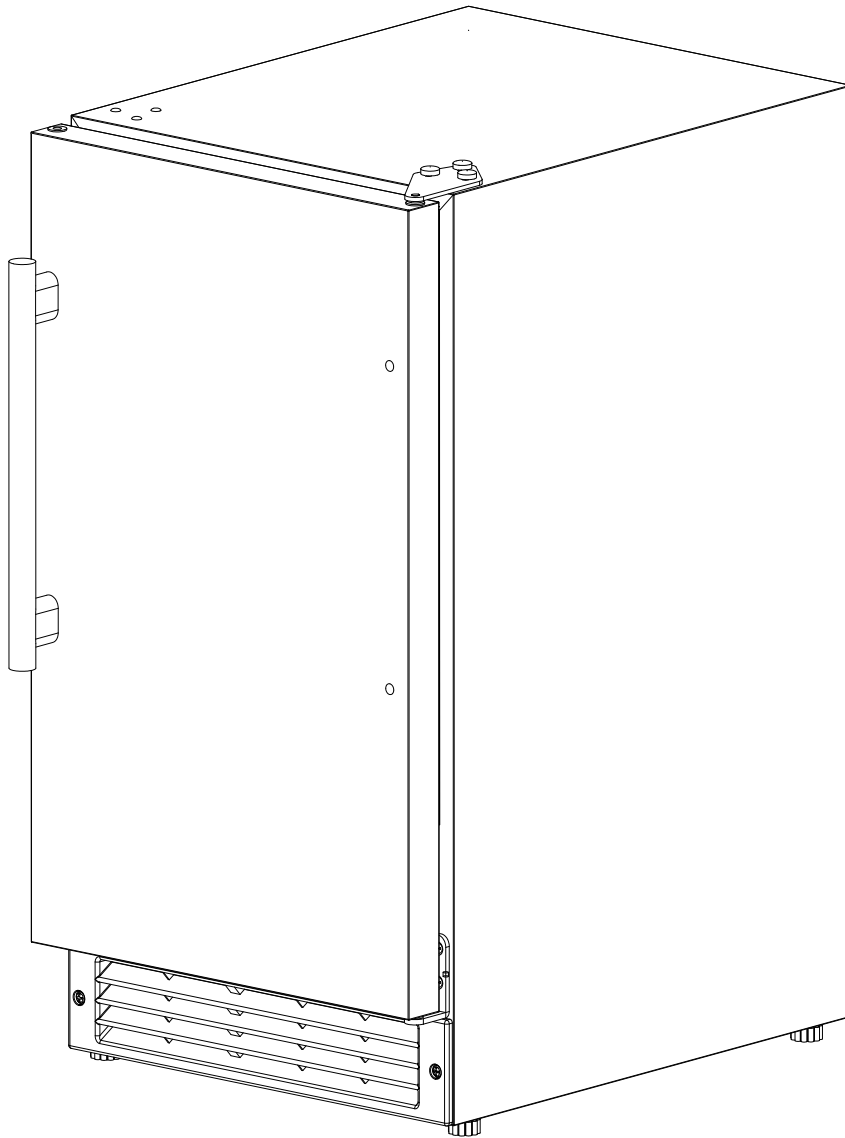

Crescent Ice Maker
INSTRUCTION MANUAL



Model: IMC22 & IMC25BI

IMPORTANT SAFETY INSTRUCTIONS

POWER CORD PRECAUTIONS

- Do not use the appliance if the power cord is damaged. If the power cord is damaged, have a qualified electrician replace the power cord.
- Never lift, carry or drag the appliance by the power cord.
- Do not connect or disconnect the electric plug when your hands are wet.
- Never unplug the appliance by pulling on the power cord. Always grip the plug firmly and pull straight out from the outlet.

MOVING PRECAUTIONS

- When moving the appliance, do not turn it upside-down and do not unlevel it more than 45 degrees.
- Do not move the appliance without emptying it and securing the door in the closed position.

INSTALLING PRECAUTION

- Connect to potable water supply only.

OTHER PRECAUTIONS

- To ensure proper ventilation for the appliance, keep obstructions away from the front of the unit.
- Keep fingers out of the “pinch point” areas. Clearance between the door and cabinet are necessarily small. Be careful closing the door when children are in the area.
- Do not touch the evaporator with your hand when the appliance is operating.
- Do not attempt to repair or replace any part of your appliance unless this manual specifically recommends it. Have a qualified technician perform all other service on the unit.
- Children 8 years of age and older and people with reduced physical, sensory or mental capabilities or lack of experience and knowledge can use this appliance if they have been given supervision or instruction concerning use of the appliance in a safe way and they understand the hazards involved.
- Never allow children to operate, play with or crawl inside the appliance.
- Never allow children to clean and maintain the machine without supervision.
- Do not use the appliance other than for its intended purpose.
- Do not touch the condenser surfaces. They are sharp and can be easily damaged.

CLEANING AND MAINTENANCE PRECAUTIONS

- Never clean the appliance parts with flammable fluids. Do not store or use gasoline or other flammable vapors and liquids in the vicinity of this appliance or any other appliances. The fumes can create a fire hazard or explosion.
- Do not use solvent-based cleaning agents or abrasives on the interior. These cleaners may transmit taste to the ice cubes, or damage or discolor the interior.
- If the appliance will not be used for a long time, thoroughly clean it before the next use. Carefully follow any instructions provided for cleaning or the use of sanitizing solution. Do not leave any solution inside the appliance after cleaning.

THE MANUFACTURER DISCLAIMS ANY RESPONSIBILITY IF THE ABOVE INSTRUCTIONS ARE NOT FOLLOWED.

TABLE OF CONTENTS

Product overview and Specs	3 - 4
Installation	
Before Using Your Ice Maker	5
Installation The Ice Maker	5
Reversing The Door Swing	6
Electrical Connection	7
Extension Cord	7
Connecting The Water Supply	7
Operating	
Initial Start-Up Operation	8
Maintenance	
Cleaning Your Ice Maker	8
Power Failure	9
Vacation Time/Storage	9
Moving Your Ice Maker	9
Energy-Saving Tips	9
Troubleshooting	10-11

Product overview and Specs

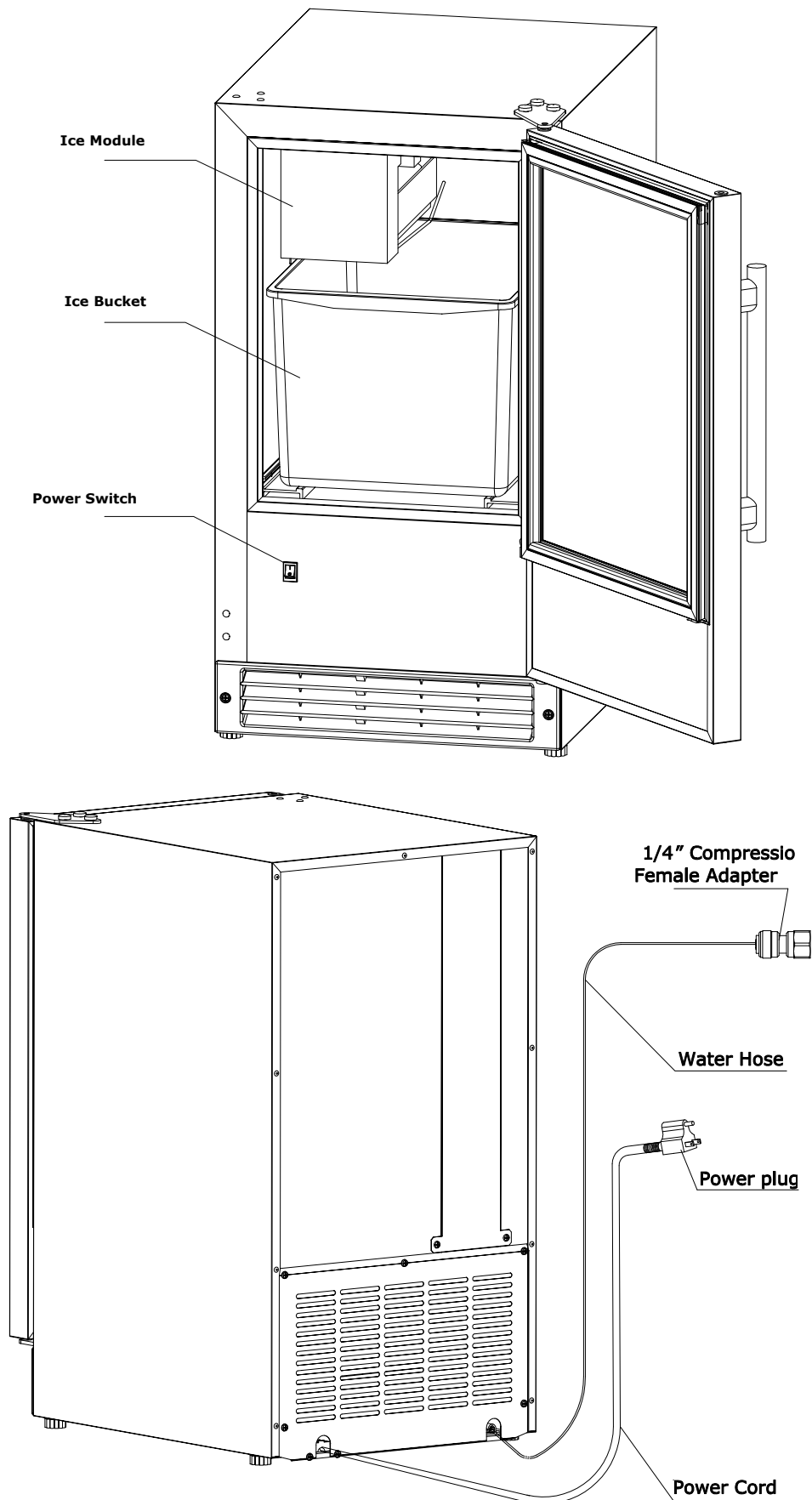

Accessories

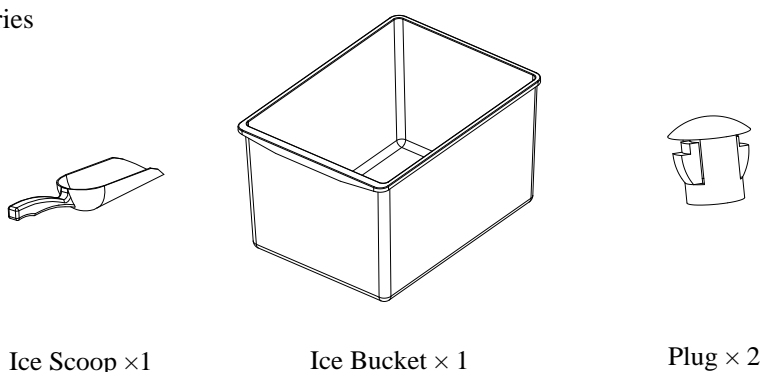

Ice Scoop ×1

Ice Bucket × 1

Plug × 2

Model	IMC22	IMC25BI
Voltage/Frequency	AC 115V 60Hz	
Rated Ice making current	1.2A	1.9A
Rated Ice harvest current	1.5A	1.5A
Refrigerant	R600a, 1.69Oz.	R600a, 1.58Oz.
Indoor/Outdoor	Indoor	
IP Rating	-	-
ADA	-	-
Installation Type	Free standing / Built-in	
Working temperature	50°F - 90°F	
Working water pressure	20 ~ 120 Psi	
Ice Storage Capacity	22 lbs. maximum	22 lbs. maximum
Ice-making Capability at 50°F	22 lbs./day**	22 lbs./day**
Ice Shape	Crescent	
Ice Cube Dimensions (Approximate)	1/2" × 3/4" × 2-3/8"	13/16" × 7/8" × 2-3/8"
Unit Dimension (W×D×H)	14-7/8"×21-11/32"× 27-3/4"	14-7/8"×18-1/2"× 33-13/16 "
Net Weight	60lb	62lbs

*The actual quantity of ice produced per day will vary with ambient room and water conditions.
 Note: Technical data and performance information are provided for reference only and subject to change.

Installation

BEFORE USING YOUR ICE MAKER

- REMOVE THE EXTERIOR AND INTERIOR PACKAGING MATERIAL.
- CHECK TO BE SURE YOU HAVE ALL OF THE FOLLOWING PARTS:
 - 1 DOOR HANDLE & 2 SCREWS
 - 2 DECORATIVE PLUGS
 - 1 ICE BUCKET
 - 1 ICE SCOOP
 - 1 INSTRUCTION MANUAL (THE ONE YOU ARE READING)
- BEFORE CONNECTING THE ICE MAKER TO THE POWER SOURCE, LET IT STAND UPRIGHT FOR APPROXIMATELY 4 HOURS. THIS WILL REDUCE THE POSSIBILITY OF A MALFUNCTION IN THE COOLING SYSTEM FROM HANDLING DURING TRANSPORTATION.
- CLEAN THE INTERIOR SURFACE WITH LUKEWARM WATER USING A SOFT CLOTH.

INSTALLATION THE ICE MAKER

- THIS APPLIANCE IS DESIGNED TO VENT HOT AIR THROUGH THE FRONT VENT. THIS ALLOWS FOR INSTALLATION IN A RECESSED OR BUILT-IN APPLICATION, IF DESIRED.

- PLACE YOUR ICE MAKER ON A LEVEL SURFACE THAT IS STRONG ENOUGH TO SUPPORT THE ICE MAKER WHEN IT IS FULLY LOADED. REMEMBER THAT THE UNIT WILL BE SIGNIFICANTLY HEAVIER ONCE IT IS OPERATIONAL AND FULLY LOADED. LEVEL YOUR ICE MAKER BY ADJUSTING THE LEGS AT THE FRONT OF THE ICE MAKER.

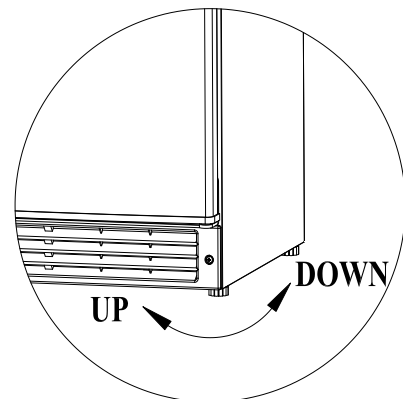

- LOCATE THE ICE MAKER AWAY FROM DIRECT SUNLIGHT AND SOURCES OF HEAT (STOVE, HEATER, RADIATOR, ETC.). DIRECT SUNLIGHT MAY AFFECT THE FINISH AND HEAT SOURCES MAY INCREASE ELECTRICAL CONSUMPTION. EXTREME COLD AMBIENT TEMPERATURES MAY ALSO CAUSE THE ICE MAKER MALFUNCTION. THIS ICE MAKER IS DESIGNED FOR INSTALLATION INDOORS IN "ROOM TEMPERATURE" AMBIENT CONDITIONS.

- POSITION UNIT TO ALLOW FREE AIRFLOW THROUGH THE FRONT GRILLE, AVOID LOCATING THE ICE MAKER IN MOIST/HUMID AREAS. TOO MUCH MOISTURE IN THE AIR WILL CAUSE FROST TO FORM QUICKLY ON THE EVAPORATOR REQUIRING FREQUENT DEFROSTING.

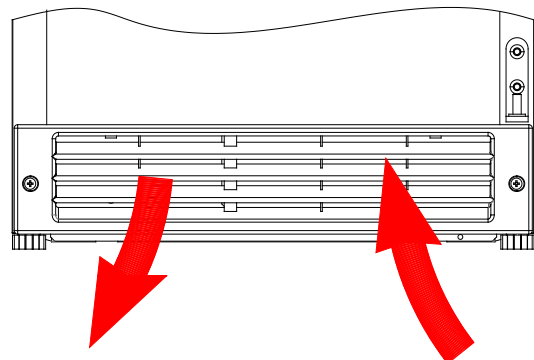

- PLUG THE ICE MAKER INTO AN EXCLUSIVE PROPERLY INSTALLED GROUNDED WALL OUTLET. DO NOT UNDER ANY CIRCUMSTANCES CUT OR

REMOVE THE THIRD (GROUND) PRONG FROM THE POWER CORD. ANY QUESTIONS CONCERNING POWER AND/OR GROUNDING SHOULD BE DIRECTED TOWARD A CERTIFIED ELECTRICIAN.

- The product is designed and manufactured for seamless integration in the specified cutout opening shown, which requires precise measurements. The opening must be square and plumb front to back. Although not required, you may choose to increase the overall cutout width for ease of installation.

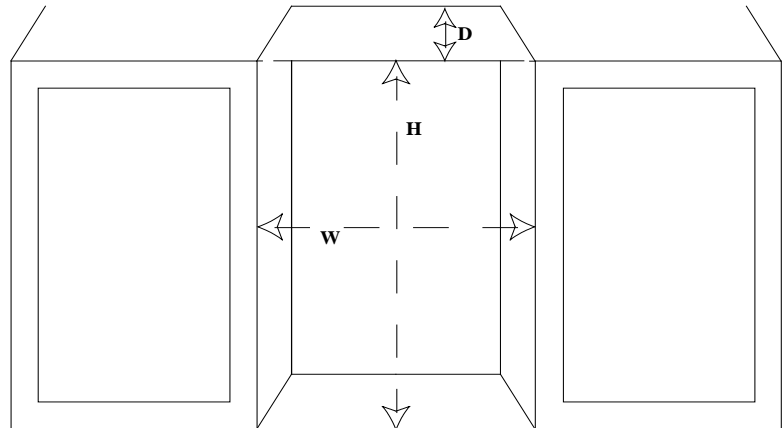

We recommend to leave at least 2" for back, 1/4" for top and sides.

REVERSING THE DOOR SWING

THIS APPLIANCE HAS THE CAPABILITY OF THE DOOR OPENING FROM EITHER THE LEFT OR RIGHT SIDE. THE UNIT IS DELIVERED TO YOU WITH THE DOOR OPENING FROM THE LEFT SIDE (HINGED ON THE RIGHT).

Tools needed: flathead screwdriver, Phillips screwdriver

IMPORTANT: Before you begin, Make sure the ice maker is unplugged.

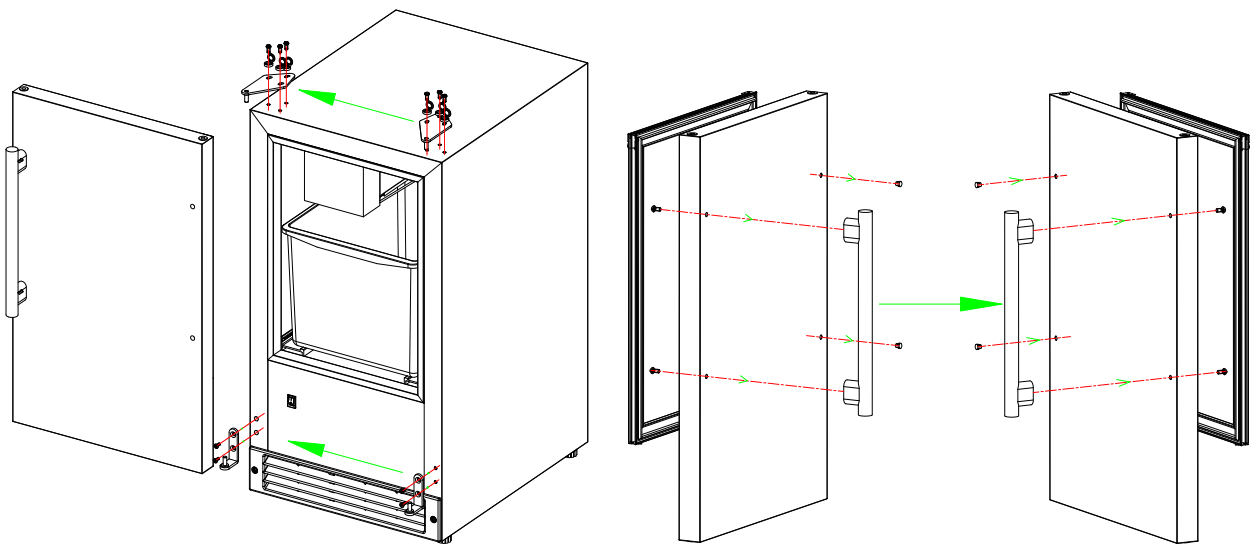

1. Open the screw cap on the top hinge and unscrew 3 bolts to take away the top hinge and then lift out the door.
2. Peel off the door gasket, located the door handle mounting screw behind the gasket and unscrew to take out the door handle, use the spare plugs in the accessories to cover the mounting hole.

3. Take away the 2 plugs in the front of the door, install the door handle on the opposite position, then push to insert the door gasket back. finish the door handle reverse.
4. Unscrew to take away the bottom hinge, and then remove the caps in the left of the cabinet and install the bottom hinge at the left.
5. Install the door on the bottom hinge, and then install the top hinge on the left. Tighten firmly.
6. Done.

ELECTRICAL CONNECTION

- THIS ICE MAKER SHOULD BE PROPERLY GROUNDED FOR YOUR SAFETY. THE POWER CORD OF THIS ICE MAKER IS EQUIPPED WITH A THREE-PRONG PLUG WHICH MATES WITH STANDARD THREE PRONG WALL OUTLETS TO MINIMIZE THE POSSIBILITY OF ELECTRICAL SHOCK.
- DO NOT UNDER ANY CIRCUMSTANCES CUT OR REMOVE THE THIRD GROUND PRONG FROM THE POWER CORD SUPPLIED.
- DO NOT USE AN EXTENSION CORD TO CONNECT POWER TO THE UNIT.
- DO NOT USE A TWO-PRONG GROUNDING ADAPTER.
- IF YOU ONLY HAVE A TWO-PRONG WALL RECEPTACLE, CONTACT A QUALIFIED ELECTRICIAN TO HAVE IT REPLACED WITH A 3-PRONG RECEPTACLE IN ACCORDANCE WITH APPLICABLE ELECTRICAL CODES.
- THIS ICE MAKER REQUIRES A STANDARD 115 VOLTS A.C. 60HZ ELECTRICAL OUTLET WITH THREE-PRONG GROUND.
- THE CORD SHOULD BE SECURED BEHIND THE ICE MAKER AND NOT LEFT EXPOSED OR LOOSE

EXTENSION CORD

BECAUSE OF POTENTIAL SAFETY HAZARDS, THIS APPLIANCE IS NOT RECOMMENDED FOR USE WITH AN EXTENSION CORD. HOWEVER, IF YOU MUST USE AN EXTENSION CORD, USE ONLY A UL/CUL-LISTED, 3-WIRE GROUNDING TYPE APPLIANCE EXTENSION CORD WITH A GROUNDING TYPE PLUG AND OUTLET. THE ELECTRICAL RATING OF THE CORD MUST BE 115 VOLTS AND AT LEAST 10 AMPS.

CONNECTING THE WATER SUPPLY

ALL THE NECESSARY HARDWARE IS **NOT PROVIDED** (AS THE PLUMBING FIXTURES AT THE INSTALLATION POINT MAY DIFFER) FOR INSTALLATION SO IT IS NECESSARY TO HIRE A PROFESSIONAL LICENSED PLUMBER TO COMPLETE THE INSTALLATION.

- CONNECT THE WATER SUPPLY TUBE TO THE NEAREST COLD WATER SOURCE. CONNECT SUFFICIENT TUBING TO THE UNIT TO ALLOW THE APPLIANCE TO BE MOVED FREELY FOR CLEANING AND SERVICE. ALSO MAKE SURE THAT THE TUBING IS NOT PINCHED OR DAMAGED DURING TRANSPORTATION/INSTALLATION.
- WIPE OUT INSIDE OF UNIT AND ICE BUCKET WITH A DAMP CLOTH.

Operating

INITIAL START-UP OPERATION

1. PLUG THE APPLIANCE INTO A 115/120V POLARIZED AND GROUNDED WALL ELECTRICAL OUTLET.
2. PLACE THE ON-OFF SWITCH IN THE "I" POSITION.
3. MAKE SURE THE WATER SUPPLY IS ON. AS SOON AS THE INNER MECHANISM REACHES THE PROPER TEMPERATURE, THE ICEMAKER MECHANISM WILL FILL THE MOLD WITH WATER.
4. THE FIRST CUBES MAY BE SMALL BECAUSE OF AIR IN THE WATER LINE. LATER CUBES WILL BE OF STANDARD CRESCENT TYPE SIZE.
5. APPROXIMATE TIME FOR THE FIRST CYCLE IS BETWEEN 30-40 MINUTES.
6. EACH CYCLE APPROXIMATELY WILL TAKE 5 OZS OF WATER SO YOU SHOULD HAVE A FULL TRAY, AFTER 11 HOURS.

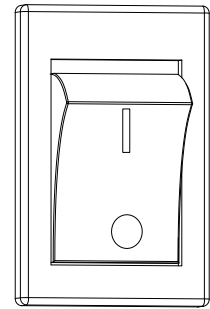

IMPORTANT: THROW AWAY ALL ICE CUBES MADE DURING THE FIRST 3 HOURS OF OPERATION.

- WHEN THE ICE BUCKET IS FULL, THE ICE MAKING MECHANISM WILL AUTOMATICALLY SHUT OFF. WHEN ICE CUBES ARE MELTED, THE ICE MAKING MECHANISM WILL START AGAIN .
- ICE DELIVERY MAY BE INTERRUPTED BY RAISING THE METAL ARM INTO AN UPRIGHT POSITION
- IF THE ICEMAKER IS NOT USED REGULARLY, IT IS RECOMMENDED THAT THE ICE BUCKET BE EMPTIED PERIODICALLY TO INSURE FRESH ICE.
- SOMETIMES THE CUBES MAY APPEAR CLOUDY. THIS IS DUE TO THE RAPID FREEZING OF THE ICE CUBE. THIS IS TRAPPED AIR IN THE WATER AND DOES NOT AFFECT THE TASTE AND QUALITY OF THE ICE.
- THE FRONT GRILLE SHOULD BE KEPT FREE OF DUST AND LINT TO ALLOW FREE AIRFLOW.

IMPORTANT: THIS UNIT SHOULD BE DEFROSTED APPROXIMATELY EVERY 4-6 WEEKS OR WHEN FROST ON THE ICE MAKER WALLS IS EXCESSIVE OR ¼" THICK. TO DEFROST, TURN THE UNIT OFF, REMOVE CUBES AND KEEP DOOR OPEN AT LEAST TWO INCHES.

Maintenance

CLEANING YOUR ICE MAKER

- TURN THE SWITCH CONTROL TO "OFF", UNPLUG THE ICE MAKER AND REMOVE THE BUCKET.
- WASH THE INSIDE WITH A WARM WATER AND BAKING SODA SOLUTION. THE SOLUTION SHOULD BE ABOUT 2 TABLESPOONS OF BAKING SODA TO A QUART OF WATER.
- WASH THE BUCKET WITH A MILD DETERGENT SOLUTION.
- THE OUTSIDE OF THE ICE MAKER SHOULD BE CLEANED WITH MILD DETERGENT AND WARM WATER.
- THE STAINLESS STEEL COMPONENTS OF THE DOOR SHOULD BE CLEANED WITH STAINLESS STEEL CLEANER
- THE CONDENSER COILS SHOULD BE VACUUMED WHEN THEY ARE DUSTY OR DIRTY

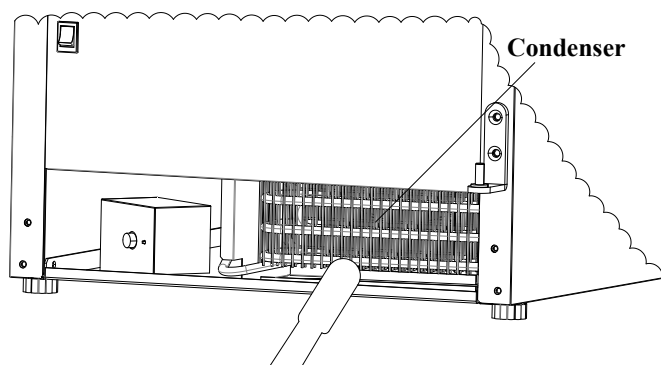

CAUTION

FAILURE TO UNPLUG THE ICE MAKER WHEN CLEANING, MOVING, OR SERVICING IT COULD RESULT IN ELECTRICAL SHOCK OR PERSONAL INJURY.

POWER FAILURE

MOST POWER FAILURES ARE CORRECTED WITHIN A FEW HOURS AND SHOULD NOT AFFECT THE TEMPERATURE OF YOUR ICE MAKER IF YOU MINIMIZE THE NUMBER OF TIMES THE DOOR IS OPENED. IF THE POWER IS GOING TO BE OFF FOR A LONGER PERIOD OF TIME, YOU SHOULD TAKE THE PROPER STEPS TO DISCONNECT YOUR APPLIANCE.

VACATION TIME/STORAGE

1. SHUT OFF THE WATER SUPPLY AT THE MAIN WATER VALVE.
2. DISCONNECT THE WATER SUPPLY LINE FROM THE VALVE.
3. POUR AWAY THE WATER AND ICE THAT IN THE ICE BUCKET.
4. ALLOW THE UNIT TO RUN FOR AN HOUR OR TWO UNTIL ALL REMAINING ICE CUBES HAVE BEEN EJECTED AND ALL WATER HAS CYCLED THROUGH THE SYSTEM AND HAS BEEN MADE INTO ICE CUBES.
5. DISCONNECT THE UNIT FROM THE MAIN POWER SOURCE.
6. DRY OUT EXCESS WATER FROM THE ICE MAKER ASSEMBLY
7. LEAVE THE DOOR OPEN AT LEAST TWO INCHES.

MOVING YOUR ICE MAKER

- SECURELY TAPE DOWN ALL LOOSE ITEMS INSIDE YOUR ICE MAKER.
- TURN THE LEVELING SCREWS UP TO THE BASE (THEIR SHORTEST LENGTH POSSIBLE) TO AVOID DAMAGE.
- TAPE THE DOOR SHUT.
- MAKE SURE THE ICE MAKER STAYS IN THE UPRIGHT POSITION DURING TRANSPORTATION.

ENERGY SAVING TIPS

- THE ICE MAKER SHOULD BE LOCATED IN THE COOLEST AREA OF THE ROOM, AWAY FROM HEAT SOURCES, AND OUT OF THE DIRECT SUNLIGHT.

TROUBLESHOOTING GUIDE

Before Calling for Service:

If the unit appears to be malfunctioning, read through the “Operation” section of this manual first. If the issue persists, check the Troubleshooting Guide below. Some of the problems mentioned in the Troubleshooting Guide can be solved easily without a service call.

Problem	Possible Cause	Probable Correction
The ice maker doesn't operate.	The ice maker is unplugged.	Plug in the ice maker.
	The breaker is tripped.	Check the breaker. If the problem occurs again, call for service to check for a short circuit in the unit.
	The ice maker's power button is set to OFF.	Switch the ice maker's power button to ON.
	When manually restart the unit during the ice harvesting while the ambient temperature are higher than 110°F, the unit could protective stop to prevent damage.	If the protective stop happens, don't restart the unit until the ambient temperature lower than 86°F.
	The ice storage bin is full of ice or wire shut-off arm is locked in the up position.	Remove some of the ice. Be sure the wire shut-off arm is lowered.
The water doesn't feed in after the ice maker starts.	The water supply tap is turned off.	Turn on the water supply tap.
	Water inlet valve malfunction	Call Service.
	The water supply pipe is not properly connected.	Reconnect the water supply pipe.
Water is leaking out of the unit.	The water supply connection is leaking.	Tighten the fitting.
A few water in the ice bucket	First initial RUNUP may double-fill cause the ice module overflow.	IT IS Normal. Don't panic.
No ice is produced.	The wire shut-off arm is locked in the upright position.	Lower the wire shut-off arm.
	Refrigerant leak.	Call Service.
	Ice Module malfunction.	Call Service.
	No water is being supplied to the unit.	Turn on the water or contact a plumber.
The machine makes ice, but at a very slow rate.	The condenser is dirty.	Clean the condenser.
	The air flow to the ice maker is obstructed.	Check the installation to ensure the air flow to the ice maker is not blocked.
	The ambient temperature is high, or the unit is near a heat source.	Check the installation to ensure the ambient temperature is in the proper range.
The ice cubes are partially formed.	There is not enough water in the water trough.	Check if the water supply pressure is below 20 psig. The water supply or filter may be restricted.

	The thermostat may had been tweaked to the highest temperature seting.	Tweak towards to the COLDEST.
Abnormal Ice, melting or formed together	The ambient temperature is high, or the unit is near a heat source.	Tweak towards to the COLDEST.
	The door gasket does not seal properly.	Close the door.
	Power Off.	Check Power supply.
	Refrigerant leak.	Call Service.
The unit accumulates frost and has to be defrosted often.	Door isn't properly closed OR Took way too long when taking ice from the unit.	Defrost the ice maker as needed. Keep the door closed as much as possible.
	High humidity enviroment	increase the defrost frequency
There is noise during operation.	The unit may not be leveled and secure.	Level and secure the unit.