

Assembly Instructions

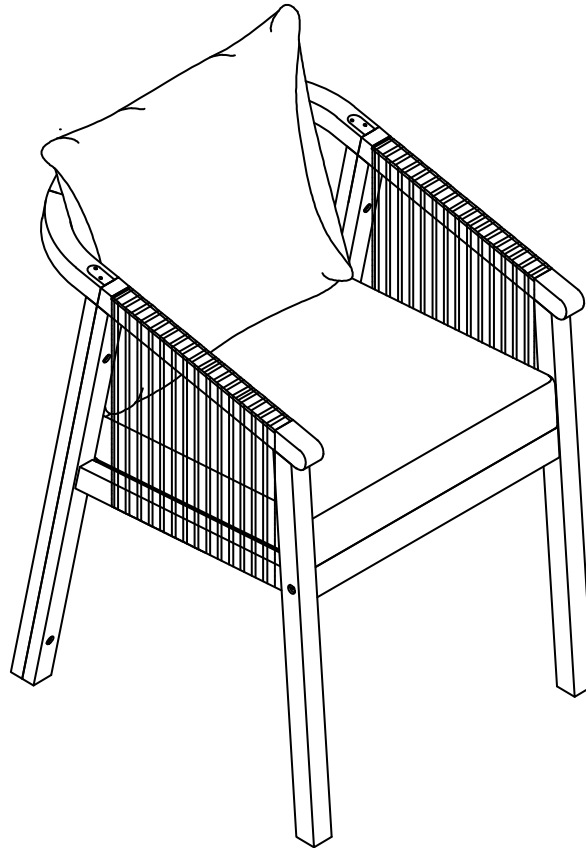

Product size:
W55*D66*H75 CM

2 PCS



**Furniture should be covered/stored whilst not in use
to prolong its longevity.**

(It should also be covered in adverse weather.)

This product is for domestic use only.

**IMPORTANT, PLEASE RETAIN FOR FUTURE REFERENCE
READ CAREFULLY**

Before you start

Warnings

IMPORTANT, RETAIN FOR FUTURE REFERENCE READ CAREFULLY

See enclosed instructions for assembly, safety and care information.

Failure to follow the warnings could result in serious injury.

Handle heavy parts with care.

Ensure that this product is fully assembled as illustrated before use.

This product should only be used on firm, level ground.

The product contains small parts which could pose a risk to young children. Keep small parts out of reach of children.

Do not stand or climb onto this product.

This product is intended for **domestic use** only.

Ensure the product is always placed on level ground.

Furniture can be dangerous if incorrectly used. No liability will be accepted for damage or injury caused by incorrect use of this product.

Take care when opening and folding furniture. Keep your hands away from moving parts in order to prevent trapping your fingers. Children should not open or close the furniture.

Dos

When you are ready to start, make sure that you have the right tools, plenty of space and a clean, dry area for assembly.

Unwrap all packaging materials and place the components on suitable surface to prevent scratching your product.

Check the pack and make sure you have all of the parts listed. In the event of problems or missing parts, please contact the seller.

Check all screws and bolts are tightened and inspect regularly.

During severe weather conditions, including high winds, rain, hail, thunderstorms, extreme heat and cold temperatures, the product should be stored inside in a cool, dry place.

To best preserve this product, please use a protective cover when your furniture is not in use. We would also recommend using a gazebo or parasol over your furniture during the summer period and prolonged sunny spells. This will help prevent harmful UV rays from damaging and discolouring the material.

Timber is a natural product and contains coloured resins which may initially bleed out of the timber when its gets wet. Therefore we recommend that care is taken to protect patios and decking from possible staining where the product comes into contact with the ground. The furniture will stabilise in its environment after the first few times it gets wet.

Wood is a natural material whose appearance will deteriorate when left outside. This product has been treated with a PU surface coating to protect it from premature darkening, or splitting, when exposed to the weather. Scuffs to the finish should be maintained regularly using the touch up liquid provided to ensure that the furniture continues to look at its best, light sanding in the affected area only may be required before use of the touch up liquid. Should you choose not to treat your furniture, then colour distortions and cracks may develop over time.

Clean your product with a sponge and warm soapy water then wipe with a clean, dry cloth.

Ensure that the product is clean and dry before storage.

Where instructions as to the; storage, commissioning, installation, use and maintenance of the goods or (if there is none) good trade practice are not followed and a defect arises this will void the 12 month manufacturer's guarantee on the product.

Don'ts

Do not use scourers, abrasives, washing powders, chemical cleaners or any other substances containing abrasives since these substances can damage the product.

To preserve the product do not place greasy / oily items directly onto the wooden surface.

Do not place very hot or very cold items on the wooden surface unless adequately thick place-mats are used to prevent such items from coming into contact with the wood.

Do not strike the product with hard or pointed items.

Do not sit or lean on the arms of this product.

Do not use power tools to construct this product.

Do not tighten screws until fully assembled.

Do not overtighten screws or bolts.

Do not use this product if parts are missing, damaged or worn.

Do not place furniture near the outdoor exhaust vents.

Do not write on furniture without a padded barrier to protect the surface.

Do not stand or climb onto the product and do not use it as a ladder, as this could lead to it unbalancing and overturning.

Never tilt the product during use.

Never drag furniture when moving it, always lift it.

The One-Seater product is intended for max use 120 kgs, Two-Seater product is intended for max use 200 kgs, Three-Seater product is intended for max use 250 kgs, do not exceed this weight.

Number of people required for assembly

Two people



Time to assemble

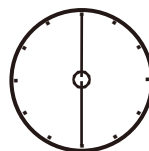



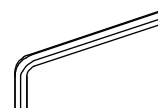

30 minutes

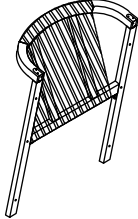
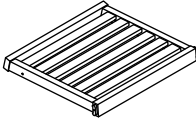

Tools required

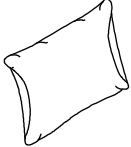
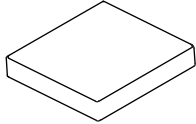
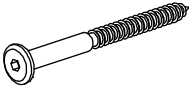
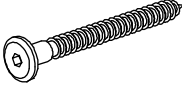
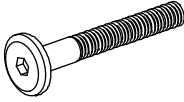

Components, fixtures & fittings (not actual size)

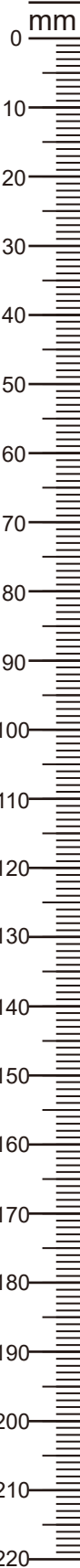
Parts List					
Part No.	Diagram	Qty.	Part No.	Diagram	Qty.
A	 Backrest	2 PCS	B	 Seat	2 PCS
C	 Right Leg/Armrest	2 PCS	D	 Left Leg/Armrest	2 PCS
F	 Backrest Cushion	2 PCS	G	 Seat Cushion	2 PCS
ST70	 Self-Taping Screw M6*70mm	4 PCS	ST50	 Self-Taping Screw M6*50mm	6 PCS
B30	 Bolt M6*30mm	12 PCS	N2	 Nut	12 PCS



AK	 Allen Key	2 PCS	Z1	 Bolt Head Cap	24 PCS (16PCS+ 8PCS Extra)
----	--	-------	----	--	----------------------------------

Step by step assembly instructions

Step One

With the help of another person, attach the Backrest (A), Right Leg/Armrest (C), Left Leg/Armrest (D) and Seat (B) together using Self-Taping Screws (ST70) and (ST50).

Please note the locations for the Self-Taping Screws (ST70) and (ST50).

ST70 is used for the Seat Front Part.

ST50 is used for the Seat Rear Part.

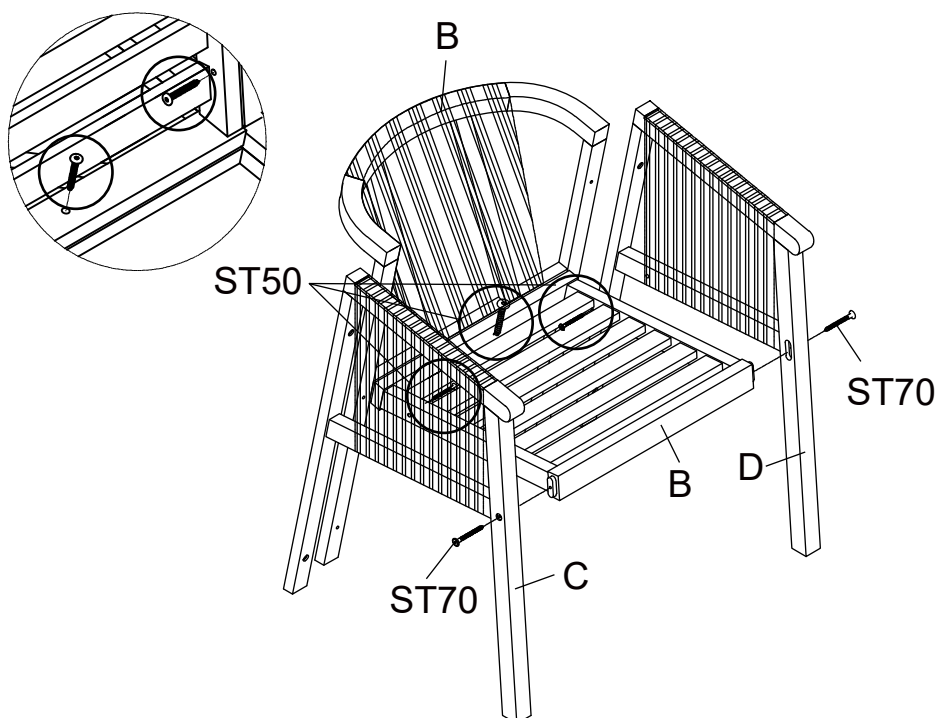

Step Two

Connect the Backrest (A) to the Right Leg/Armrest (C) and Left Leg/Armrest (D) using Bolts (B30) and Nuts (N2).

Tighten all Bolts with Allen Key (AK). Do Not Over Tighten.

Attach the Bolt Head Caps (Z1) to the Bolts' heads.

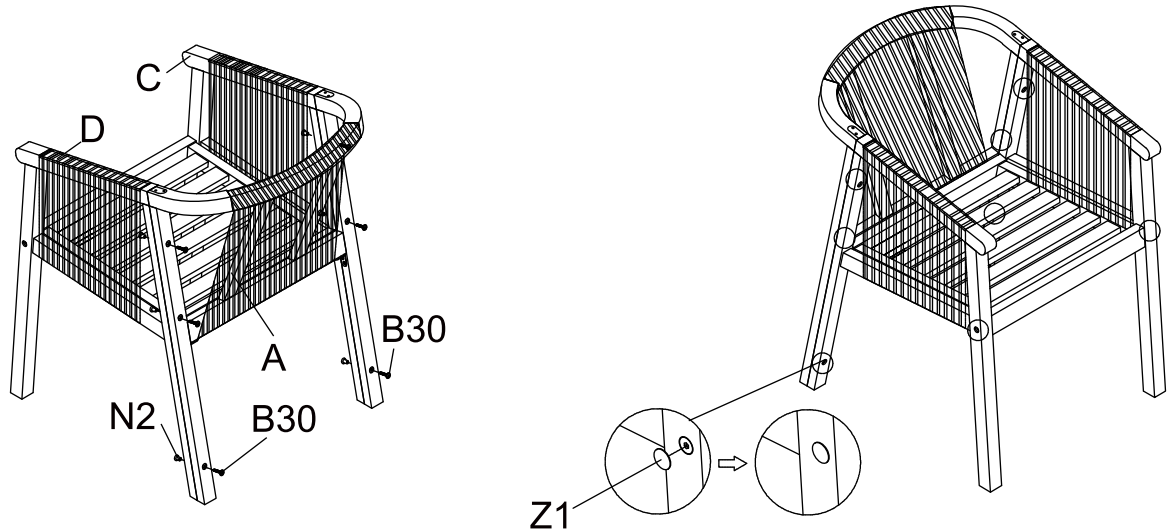

Step Three

Stand the Chair, level the Chair with Adjustable Feet Screws under the legs. Place the Seat Cushion (G) and Backrest Cushion (F) to the Seat.

Your Chair is now ready for use.

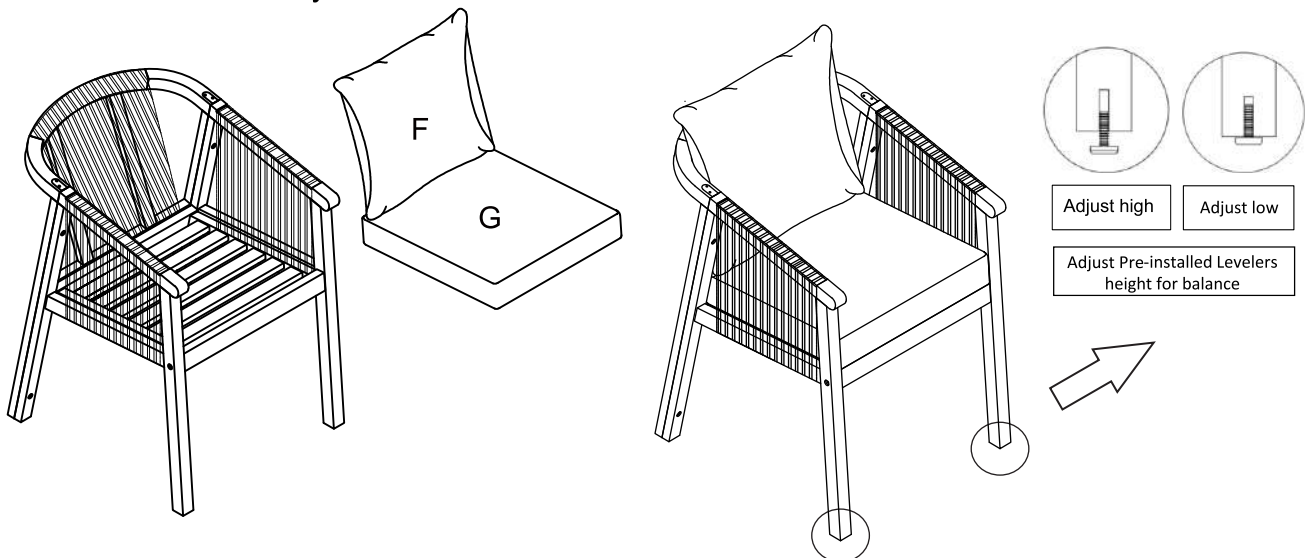

PLEASE KEEP THESE INSTRUCTIONS FOR FUTURE REFERENCE

Special Maintenance Instructions for Wooden Products

Warning!



KEEP OUT OF THE REACH OF CHILDREN

The Bottle of Lacquer PU should be kept out of the reach of children.

Maintenance Tools:

1. Soft Cloth/Wipe: Not provided
2. 20ml Bottle of Lacquer PU Light Teak Colour: Provided
3. Small Brush: Provided



Maintenance Steps:

1. Clean the surface with a clean cloth/Wipe;
2. Gently evenly brush over scratched areas;
3. With a cloth gently rub in the lacquer;
4. Allow lacquer to dry for 3 hours.

**IMPORTANT, PLEASE RETAIN FOR FUTURE REFERENCE
READ CAREFULLY**