

## NEG ARG FIBER

### Chopped Strands

### PH-950X Chopped Strands



PH-950X chopped strands is a high integrity and high tex design of the strands. It has excellent strand integrity to meet requirements of conventional premix GRC. The high tex strands can achieve excellent moldability and good reinforcing effect at high dosage.

#### ■ Product Number

**ACS9PH-950X(20)/D** ----- 9mm cut length  
**ACS13PH-950X(20)/D** ----- 13mm cut length  
**ACS19PH-950X(20)/D** ----- 19mm cut length  
**ACS25PH-950X(20)/D** ----- 25mm cut length

#### ■ Product Specifications

**Type of glass** ----- Alkali Resistant glass  
**Zirconia content** -----  $\geq 17\%$   
**Nominal strand tex (g/1000m)** ----- 138  
**Moisture content (%)\*** -----  $\leq 0.5$

\*Data measured by JIS (Japanese Industrial Standard)

#### ■ DIBt Certificate

No. Z-3.72-1730

#### ■ Process

Premix, Casting

#### ■ Applications

Glassfiber Reinforced Concrete

#### ■ Expected Effect

Disperses into strands and works for matrix reinforcement

### ■ Packaging Data

20 kg in a polyethylene bag

### ■ Palletizing Data

Product Number	Number of bags per pallet	Pallet Dimensions (mm)		
		Length	Width	Height
ACS9PH-950X(20)/D	24	1100	1100	1100
ACS13PH-950X(20)/D	24	1100	1100	1100
ACS19PH-950X(20)/D	24	1100	1100	1100
ACS25PH-950X(20)/D	24	1100	1100	1100

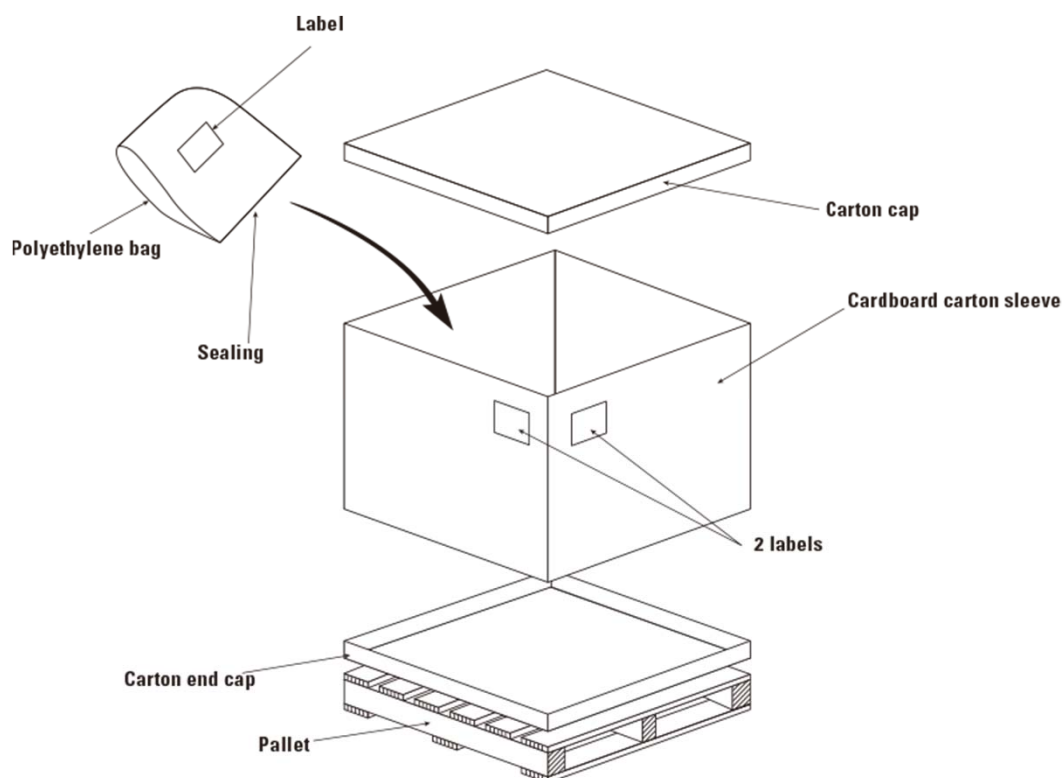

### ■ Storage Conditions

PH-950X Chopped Strands should be stored in an upright position in a dry area in its original packaging.

PH-950X Chopped Strand should be sheltered from the direct sunlight.