

MODEL # ERK-90Ma2

SMART COFFEE TABLE WITH ALL-IN-ONE REFRIGERATOR & FREEZER DRAWERS

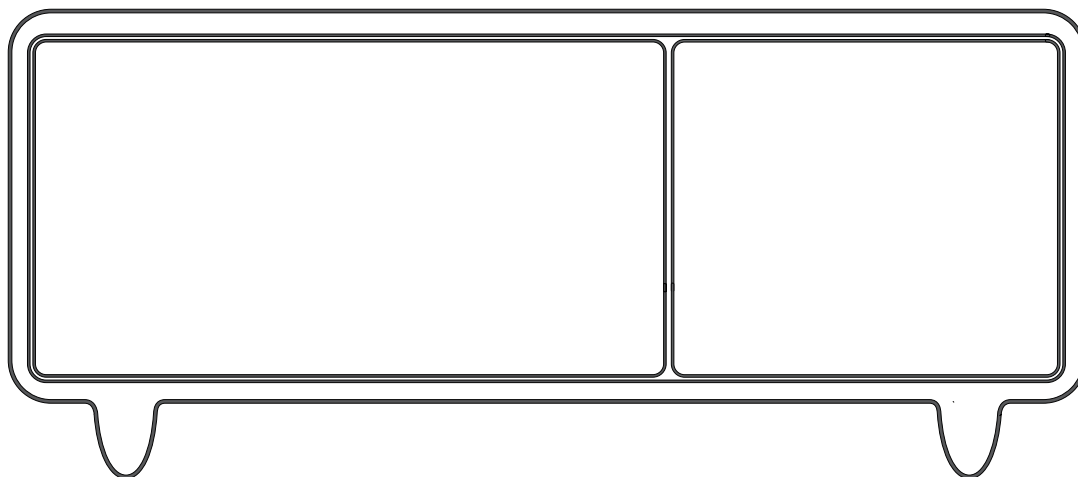

In case you might need to return this product, please keep all the packaging materials and return only in its original packaging and in excellent condition.

如需退货请保留好所有包装材料，并按原包装包好退回。

PARTS & FEATURES/各部件名称

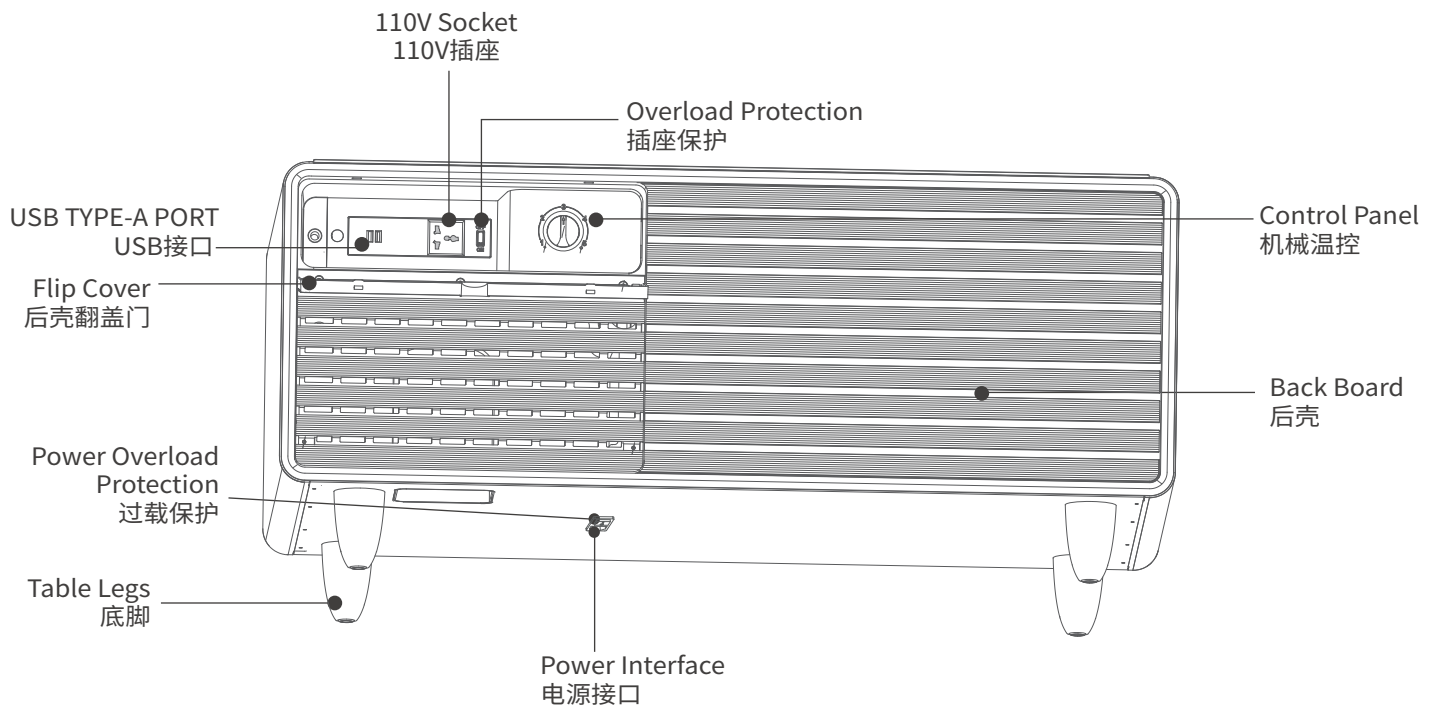
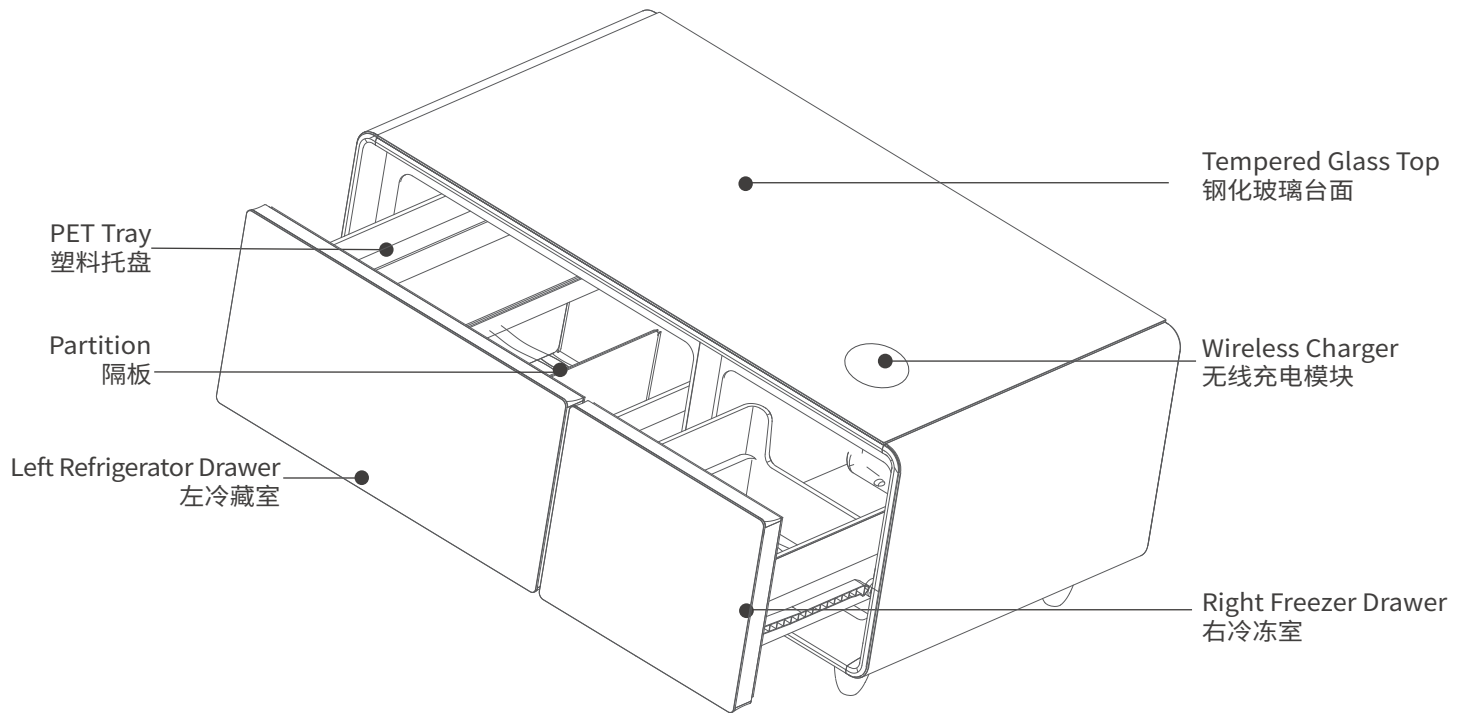



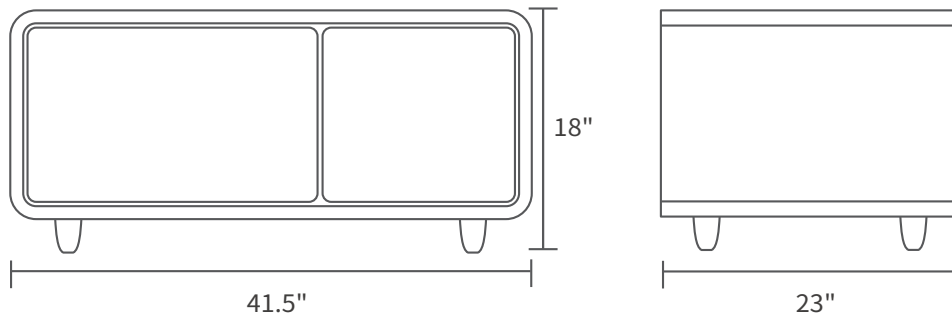

SPECIFICATIONS/技术参数

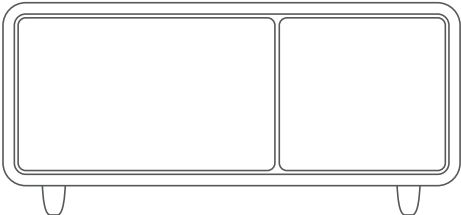

| | | | |
|----------------------------|---------------------------|-----------------------------------|----------------------------|
| Consumption 耗电量 | 128kWh/year | Packing Size 包装尺寸 | 45.5" x 27.6" x 22.4" |
| Noise Level 噪音 | 36db | Temp Control 控温方式 | Mechanical/机械控温 |
| Voltage 输入电压 | 110V-120V/60HZ | Refrigeration Mode 制冷方式 | Compressor 压缩机/直冷 |
| Net Weight 净重 | 95.9 lbs | Refrigerant/Wt 制冷剂/充注量 | R600a/42g |
| Gross Weight 毛重 | 132.3 lbs | Volume 容积 | 65L + 28L |
| Controlling 操作控制 | Mechanical Knob 机械旋钮控制 | Left Drawer Temp Range 左冷藏室温区 | 34°F~46°F 1°C~8°C |
| Product Dimensions 产品尺寸 | 41.5" x 23" x 18" | Right Drawer Temp Range 右冷冻室温区 | -13°F~3.2°F -25°C~-16°C |
| Wireless Charger 无线充电参数 | 10W | USB USB充电参数 | 5V/2.1A |

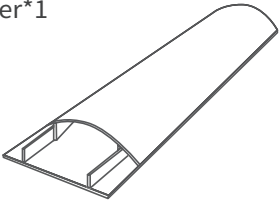
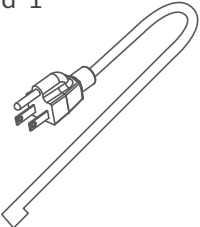
PACKING LIST/包装箱清单

| | | |
|--|--|--|
| <p>Main Body*1 主体*1</p>  | <p>Partition*2 玻璃隔板*2</p>  | <p>PET Tray*1 塑料托盘*1</p>  |
| <p>Cable Cover*1 压线槽*1</p>  | <p>Power Cord*1 电源线*1</p>  | <p>User Manual*1 说明书*1</p>  |

PRECAUTION BEFORE USE – UNPACKING/使用前注意事项

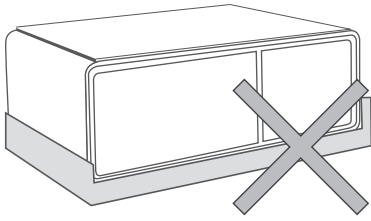

For better heat dissipation, remove the foam base, peel off the adhesive tape and the transparent film from the surface of the table. Failure to do so may result in personal injury or property damage.

拆除泡沫底座及固定用的胶带并将冰箱茶几表面的透明覆膜撕掉,以免影响冰箱茶几正常散热。

■ ENSURE ALL ACCESSORIES ARE INCLUDED ACCORDING TO THE PACKING LIST IN PAGE 3. 根据第3页的清单清点物件

■ TABLE PLACEMENT CONDITIONS / 冰箱茶几放置条件

1. Please use the cable cover to protect the power cord if your floor is not installed with power socket and carpet.
2. Avoid high humidity, super cold environment and directly sunlight places.
3. Make sure that there are enough space on all sides around the Smart Coffee Table to ensure adequate ventilation for the refrigerator (see attached picture). Do not place the back of the Smart Coffee Table against a wall as this may result in overheating.
4. The table should be put on flat and solid ground. If the table need to be raised, please choose a stable, hard and incombustible cushion block. Adjust the bottom feet to be stable. Do not use the foam material inside the packing as a cushion.

1. 在没有地插和地毯保护的情况下,请安装随机附送的压线槽,以防止脚踏,损坏电源线。
2. 避免潮湿、过冷的环境,避免阳光直射。
3. 确保茶几周围都有足够的空间(看图示),以确保产品的正常散热。不要将产品靠在墙边摆放,这会导致过热。
4. 冰箱茶几需放置于平坦坚固的地面,如需垫高,亦需选择平稳、坚硬、不可燃的垫块。如果稍有不稳,可调整冰箱茶几的可调底脚,切勿将冰箱茶几的包装泡沫垫块用来垫高冰箱茶几。

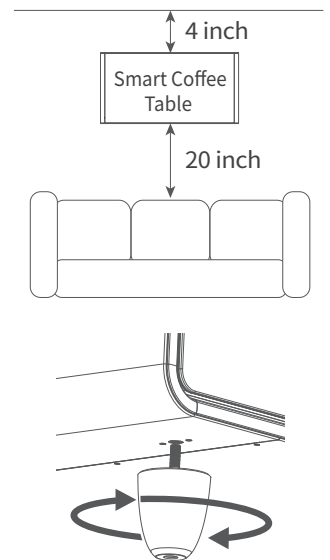

■ PLEASE CLEAN THE TABLE BEFORE USING / 使用前请先进行清洁

Please refer to page 12 for daily maintenance and repair.

清洁方法请参阅第12页“冰箱茶几的日常保养与维护”一节。

■ RESTING / 静置

After leveling and cleaning the table, do not power on at once. Before connecting the appliance to an electrical power supply, let the smart coffee table unplugged for about 2 hours in its final location, This will reduce the possibility of a malfunction in the cooling system due to mishandling or jostling in transport.

冰箱茶几安放调平、清洁完成后,先不要接通电源。让冰箱茶几静置2小时以上,再接通电源,以确保正常运转。

■ POWER ON / 接电

After unplug for 2 hours, carefully check if there is any water or foreign object around the power socket and USB ports, then connect the power cable under the bottom of the table, see picture below. Please make sure the cable is safely installed and can come in handy, to minimize daily wear and tear of the power cord and avoid users being accidentally tripped over.

静置2小时后,检查电源插口、USB内是否有水汽或异物,检查完毕后可连接电源线(冰箱茶几的电源插口在底部)。在连接电源线之前可将电源线固定。两头留有足够的长度,方便拔插以免电源线磨损减少使用寿命或绊倒用户。



The maximum power draw on the smart coffee table is 960 watts for all the outlets combined. Please do not connect to a multipurpose power outlet.

外接电器功率不能超过960W!请勿外接插线板使用!

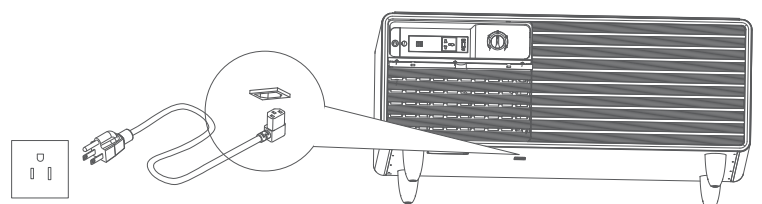

NOTICE/安全注意事项

NOTICE

ELECTRIC WARNINGS / 电气方面

1. After powering on the unit, please install the cable cover to prevent any damage of the cable. Do not step on the cable, otherwise it will raise the risk for electric leakage.
 2. The power cord should be kept in firm contact with the power source. Failure to do so may result in property damage, personal injury or fire.
 3. To avoid damage to the cable, please do not step on the cable. Do not roll over the cable when moving the table.
 4. When removing the power plug from the wall outlet, always pull directly on the plug, never pull the cord. Before cleaning, repairing or replacing any parts, unplug the table to avoid electric shock.
 5. Do not use if the power cord is damaged or the plug is worn. Please make sure to go to the manufacturer's designated repair center or online authorized dealer for replacement.
 6. For this R600a refrigerator, please ensure that maintenance is carried out by professionally trained technicians. If the equipment is damaged, please send it to a nearby service center for inspection, repair or adjustment.
1. 冰箱茶几接通电源后, 必须安装随机附送的电源线压线槽, 防止鞋子长期踩踏电源线, 导致电源线表面存在漏电的危险。
 2. 电源线插头应保持与插座和冰箱茶几牢固接触, 否则可能导致火灾!
 3. 为了防止电源线的损坏, 不要让箱体底角压住电源线或人为踩踏电源线, 移动冰箱茶几时, 请小心谨慎, 切勿滚压电源线。
 4. 切勿以拉扯电源线的方法拔出冰箱茶几的插头, 一定要紧紧握住插头, 从插座中直接拔出。清洁、维修及更换损坏的照明设备前, 必须拔下冰箱茶几的电源插头, 以防触电。
 5. 当电源线出现破损或插头出现磨损时, 切勿使用, 必须到厂家指定的维修点或网上专卖店更换。
 6. 必须由经过专业培训的维修人员进行检修。如设备损坏, 请将设备送回到附近的服务中心进行检查, 维修或调整。

POWER SUPPLY WARNING / 电源警告

This table should be powered by AC110V. If the voltage fluctuation is out of range, it may cause unit failure, property damage or personal injury.

本产品应使用交流110V电源。如果电压波动超出范围, 可能导致设备故障、财产损失和人身伤害。

GROUND POWER WARNING / 接地

Use a dedicated socket and ground the device properly. The power cord is equipped with a three-wire (grounding) plug and should be used with a standard three-wire (grounding) socket. Under no circumstances should the third prong (grounding) of the power cord be cut off or removed.

必须使用专用插座并进行接地, 电源线配有三线(接地)插头和符合标准的三线(接地)插座, 任何情况下切勿切除或拆除电源线的第三插脚(接地)。

STORAGE WARNING / 存储

This table should not be used to store any products that are inflammable, explosive or dangerous, as well as any chemicals. Blood or other biological products is prohibited to be stored in it.

冰箱茶几不能用来存放任何易燃、易爆或危险的产品, 以及任何化学品。血液或其他生物制品禁止存放于此。

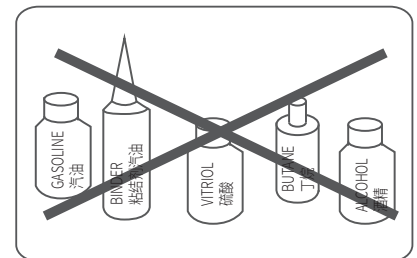

USB / USB接口

Keep liquids away from USB ports. Do not use wet cloth to clean the ports.

防止USB短路, 为保证安全, 应注意避免液体流入USB接口内。在清洁时切勿使用带水的抹布擦拭USB接口。

110 POWER INLECT / 110V电源接口

1. Keep liquids away from socket. Do not use wet cloth to clean.
2. The rated power of connecting this electric appliance cannot exceed 960W. Overloading will lead to over heating and will cause fire. Even will cause property damage or personal injury.
3. Please do not connect to a multipurpose power outlet.

1. 为防止短路, 保证安全, 应注意避免液体流入电源接口内。在清洁时切勿使用带水的抹布擦拭电源接口。
2. 连接电器的额定功率不能超过960W。超载将导致过热和火灾, 并将导致财产损失和人身伤害。
3. 请勿使用外接插线板。

■ WIRELESS CHARGER / 无线充电装置

1. If the device is equipped with a thick protective shell or a metal protective shell, the charging efficiency may be affected. Remove the shell and try again.
2. The wireless charger may generate heat when charging. If the battery overheats, the software may limit the charging. It will begin to charge once the temperature drops.
3. Wireless charging and the USB charging should not be used in the same time.

1. 如果设备装有厚保护壳或金属保护壳, 充电效率可能会受到影响。取下设备外壳并重新尝试。
2. 无线充电装置在充电时可能会产生热量。如果电池过热, 软件可能会限制充电。一旦温度下降, 可再进行充电。
3. 无线充电和USB充电不应在同一时间使用。

■ REPAIR / 维修

It is strictly prohibited to disassemble or modify the table and damage the refrigeration pipeline by yourself. Maintenance of the table must be carried out by professional personnel.

严禁私自拆卸、改造冰箱茶几, 禁止损坏制冷管路。维修冰箱茶几必须由专业人员进行。

■ PLACEMENT ENVIRONMENT / 放置环境

1. Smart Coffee table should be placed far away from any heat source and do not expose to direct sunlight.
2. Smart Coffee table should be placed in a well ventilated area, please refer to TABLE PLACEMENT CONDITIONS.
3. Do not place the smart coffee table in damp areas or where the equipment may come into contact with water. Do not place power sockets, voltage stabilizers, or small appliances on the refrigerator coffee table.
4. Do not put unstable objects on the smart coffee table to avoid damage to the table top.
5. Be cautious when placing objects with liquid on table. Spilling liquid can result in property damage, personal injury or electric shock.
6. Do not store gas or any other flammable materials in or near the smart coffee table to avoid possible fire hazard.
7. If there is any gas or other flammable material leak around the unit, close the gas valve and open all doors and windows immediately. DO NOT PULL OR TOUCH THE SMART COFFEE TABLE ELECTRIC PART.

1. 冰箱茶几应远离任何热源, 避免阳光直射。
2. 冰箱茶几应放置在通风良好的地方, 请查阅冰箱放置条件一节。
3. 不要将冰箱茶几放置在潮湿的地方或设备可能遇到水的地方。不要把电源插座、稳压电源或小电器放在冰箱茶几上。
4. 不要把不稳定的物体放在冰箱茶几上, 以免损坏桌面。
5. 在冰箱茶几上放置带有液体的物体时要小心。液体溢出会导致财产损失、人身伤害和触电。
6. 不要在冰箱茶几内或附近存放气体或任何其他易燃物, 以免引起火灾。
7. 如果设备周围有任何气体或其他易燃物泄漏, 请立即关闭气体阀门并打开所有门窗。不要拉动或触摸冰箱茶几的电器部件。

■ PLACEMENT OF POWER CORD / 电源线的放置

SUG 1. Please leave enough place for ground plug if your house is under decoration or renovation.

建议1: 正在装修或打算装修的朋友们, 记得在冰箱茶几放置位置预留地插哦!

Ground plug placement suggestion:
地插位置建议:

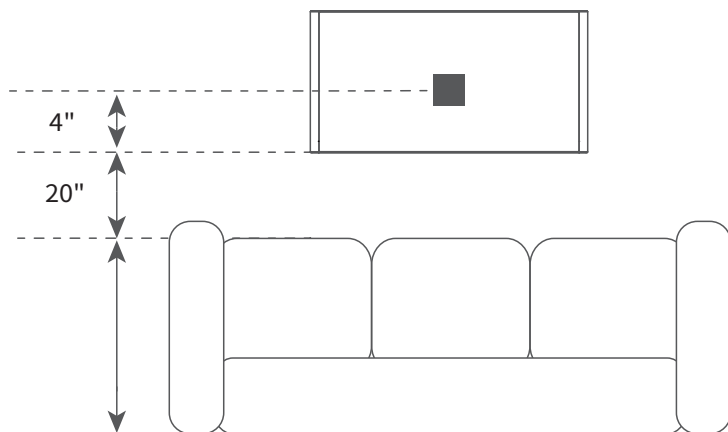

SUG 2. You can buy a carpet to hide the ground power cord.

建议2: 请购买一张精致的地毯隐藏冰箱茶几的电源线。

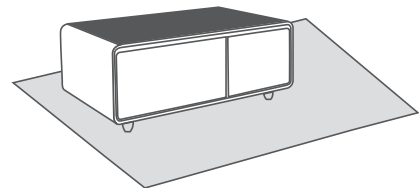

SUG 3. You can also use the attached cable cover to hide the power cord to avoid any tripping.

建议3: 也可以使用附送的压线槽去隐藏电源线, 防止绊倒的情况发生。

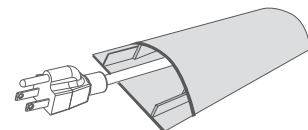

INSTALLING THE POWER CORD/电源线的安装

GROUNDING INSTRUCTIONS / 接地说明:

This appliance must be plugged into a grounded socket. The power cord that is supplied with the appliance contains the appropriate grounding conductor and grounding plug.

The plug must be inserted into a outlet that has been grounded in accordance with the existing local codes and ordinances. The required nominal voltage and frequency are indicated on the rating label. Consult a qualified electrician for other concerns.

该设备必须插入接地插座中。该设备提供的电源线包含接地导体和接地插头。

必须将插头插入合规的插座中。请查看标签上标明的额定电压和频率。如有其他疑问，请咨询专业人员。

1. Have one partner lift the right side of the Smart Coffee Table table off the ground. Rest the opposing side on a foam insert or cushion for protection.

一人在右侧把冰箱茶几从地面上抬起。在相对的一侧放泡沫或垫子以作为保护。

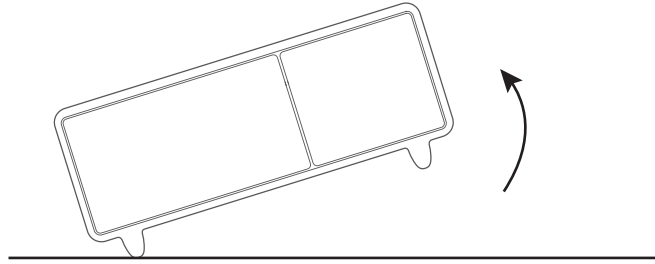

2. The power socket is located on the underside of the Smart Coffee Table towards the back right corner. Locate the socket and unwrap the power cord before attaching. Plug in the adaptor end of the cord to the socket in the indicated location below.

电源插座位于冰箱茶几底面的右后侧。在连接之前拆开电源线。将电线的适配器端插入下图指示位置的插座里。

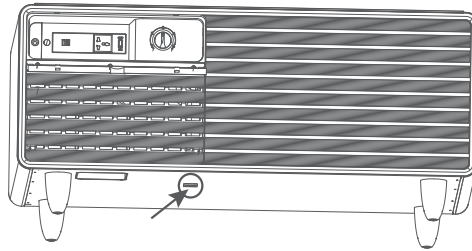

3. After installing the power cord or moving the Smart Coffee Table, you must let the refrigerator coolant settle for a minimum of 2 hours before plugging in the Smart Coffee Table.

安装好冰箱茶几后，您必须让冰箱茶几静置至少2小时，然后才能插电使用。

We repeat: Do not plug in the Smart Coffee Table until 2 hours have passed.

重复：静置2个小时后再插电使用。

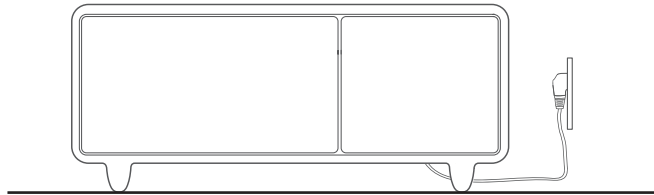

Use proper lifting technique!

Exercise caution! If you have a history of back pain or injury, do not attempt to lift table. Eureka, LLC will not accept responsibility for any injury that may occur during set up process.

使用恰当的抬起方法。

请小心！如果您有背痛或受伤的病史，请不要试图抬起冰箱茶几。Eureka, LLC对在安装过程中可能造成的任何伤害不承担责任。

FUNCTION AND FEATURES/主要功能及特点

Left Refrigerator Drawer 34°F~46°F
左冷藏室 1°C~8°C

Right Freezer Drawer -13°F~-3.2°F
右冷冻室 -25°C~-16°C

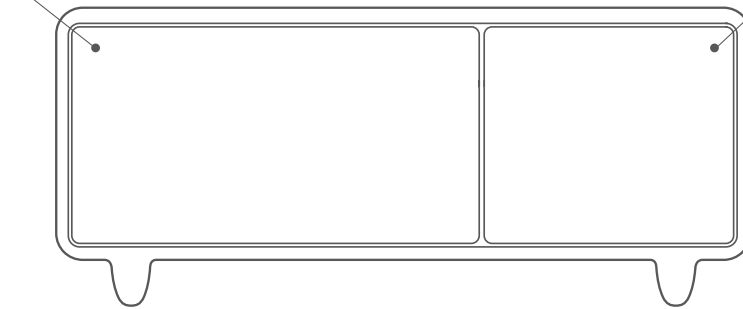

REFRIGERATOR DRAWERS / 冷藏存储室

The Smart Coffee table is designed with two drawers that can be manually controlled for the temperatures. Refrigerator drawer comes with two partitions and one tray to organize all your favorite beverages and snacks. 冰箱茶几有两个抽屉，机械旋钮统一控制调温。冷藏抽屉有隔板和托盘，可以存放所有你喜欢的饮料和零食。

CHARGERS / 充电装置

There are two types of chargers, one is 10W wireless charger located on the top and the other is USB Type chargers which is located on the back side.

冰箱茶几配有2种类型的充电装置，10W无线充和USB充电。

110V POWER SOCKETS / 110V电源插座

The smart coffee table is equipped with 110V power sockets, to supply power to other devices. The power sockets have a separate safety switch to detect high input or overload. If the safety switch detects either, it will cut off power automatically to avoid any dangerousness.

冰箱茶几配备了110V电源插座，为其他设备供电。电源插座有一个单独的安全开关来检测高输入或过载。当家用电器用电过大超出安全范围时，安全开关会自动切断电源，以避免发生危险。

HIGH EFFICIENCY COMPRESSOR / 高效压缩机制冷系统设计

The smart coffee table is equipped with a high efficiency compressor to keep your unit working at optimum performance. It can automatically adjust the ON/OFF time according to the changes in temperature inside and outside the refrigeration compartment, as well as the amount of stored food. It has powerful refrigeration capability, is environmentally friendly and energy-saving, and operates quietly.

冰箱茶几采用压缩机机械直冷系统设计，可根据冷藏箱内、外温度及储存食品量的变化自动调节开关机时间，具有超强冷藏能力，环保节能，静音工作。

PARTITION STORAGE / 分区存储

To make better use of the storage space, there are two partitions and a tray in the refrigerator drawer, which facilitate the classification and storage of food.

为了更有效地利用存储空间，冷藏抽屉里有两个隔板和一個托盘，方便食物分区存放。

REMOVABLE DOOR SEAL / 可拆卸门封条

The removable door seal will ensure the long-term sealing of the smart coffee table, making it easy for daily cleaning and maintenance, and reducing energy consumption.

可拆卸门封条将确保冰箱长期密封完整，方便日常清洁维护，减少能耗损失。

USER GUIDE/使用说明

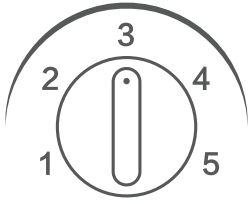

This smart coffee table adopt mechanical manual temp control, the factory default is level 3. The food refrigeration is divided into 5 levels. The higher the level, the lower temperature. e.g: the factory default is level 3, adjust to 4-5 level to lower the temp; adjust to 1-2 level to increase the temp.

冰箱茶几采用机械手动控温, 出厂默认档位3档;食品冷藏分为五个档位。档位越高, 相应的冷藏温度越低。如:出厂为3档, 调至4-5档, 增加制冷效果;调至1-2档, 减弱制冷效果。



Individual Quick Freezing (IQF): Please preset the temperature mode at Level 5 in advance. Once the items have cooled down to your ideal temperature, adjust the temp mode back to within level 4.

When the temperature setting has been adjusted, it would take some time for the temperature inside the drawers to reach to a fine balance. The length of this time depends on temperature differences, ambient temperature, and the frequency of door openings, etc.

快速降温方法:可预先调至5档, 温度到达后必须调至4档以内!

温度设定改变时, 箱内温度需经过一段时间后才能达到平衡。且这段时间的长短取决于温度设定改变的大小、环温的高低、开门频次等。

REFRIGERATOR DRAWER / 冷藏室

NOTE / 注意事项

1. Fill this refrigerator only with fresh food.
2. Do not store food that requires the refrigerator to outperform its designed temperature range.
3. Do not store food while it is hot. This would drive up the drawer temperature, thus affecting all other items inside.
4. Do not open the drawers all too often, nor leave it open for a long time. This would also destabilize the inside temperature.
5. Do not store food that is about to expire. Keep food properly sealed to avoid odor build-up.

1. 用来存放新鲜食物。
2. 不要存储需要更低温环境的食物。
3. 不要将热的食品放入冰箱茶几内, 否则会增加冰箱内部的温度, 从而影响其他食品。
4. 不要经常打开抽屉, 也不要将其打开很长时间, 这样会导致箱内温度升高。
5. 即将过期的食品请勿存放于冰箱内。请密封好食品存放, 这将有助于减少异味的产生。

Storage Suggestion / 使用技巧

1. The food should be washed and clean thoroughly before putting into the refrigerator.
2. The bottles should be closely placed to prevent tilting and falling when the door is opened.
3. Food placed in the drawer should not exceed a certain height, otherwise it may prevent the drawer from closing properly.
4. The partition can help organize different types of food, and can be adjusted according to your needs.
5. The sliding tray can be used for storing the washed fruits, (such as grapes and strawberries) without the need for a fruit plate.
6. Adjust the refrigerator temperature according to the food characteristics.

1. 食物存放在冰箱茶几时要清洗干净。
2. 瓶子应该紧密排列在一起, 防止在门开启时瓶子倾斜摔倒。
3. 抽屉中放置的食物不能超出一定的高度, 否则会造成抽屉无法正常关闭。
4. 冷藏室抽屉中的隔板可将不同类型的食物分类摆放, 可以根据需求调整隔板。
5. 冷藏室抽屉上的滑动托盘可用于存放洗净的水果(如:葡萄、草莓), 无需再使用果盘放置。
6. 可根据食品的特性, 调节冷藏室的温度。

■ USB / 手机充电插口

The smart coffee table is equipped with two USB charging interfaces. When connected to commonly used devices such as mobile phones, tablets, and desktop speakers via a data cable in a power-on state, it can be used for charging or starting smart devices. The carefully designed cable storage box can hide excess and messy power cables inside, making the whole setup look neat and tidy!

冰箱茶几设置有两个手机充电接口,在通电状态下通过数据线与手机、平板电脑、桌面音箱等常用设备连接,即可实现充电或启动智能设备。精心设置的藏线盒可以把多余、外露的电源线收藏在藏线盒内部,美观又整洁!

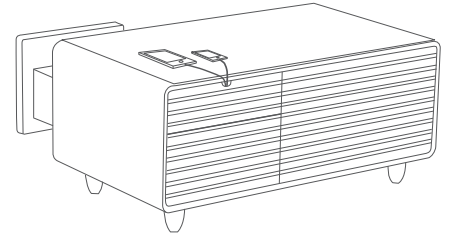

■ FREEZER / 冷冻室

NOTE / 注意事项

1. Do not place hot food in the freezer.
2. Do not put damaged or opened packages of frozen food directly into the freezer. Please make sure all food is properly sealed to avoid spoilage or deterioration.
3. Do not overfill the table drawers as this will affect the ventilation.
4. Do not store chemicals into the any of the drawers.

1. 热的食物绝对不能放入运转着的冷冻箱内。
2. 不要将包装破损或已拆封的速冻食品直接放入冷冻室,须在包装外加个塑料袋,并扎紧袋口,以免产品干燥或氧化。
3. 不要将冰箱抽屉放得太满,影响冷气对流。
4. 冰箱抽屉禁止贮藏化学药品。

■ 110V POWER / 110V电源

This table is equipped with two power ports, with a required rated current of 10A and a rated power of 960W. It can accommodate the use of both two-prong and three-prong electrical appliances.

CAUTION: DO NOT DROP WATER OR LIQUID IN ANY OF THE POWER OPENINGS.

Please do not connect to appliances that fails to match the required nominal voltage and frequency on the rating label. Please do not connect to a multipurpose power outlet.

冰箱茶几设有2个电源接口,额定电流10A,额定功率960W。可以满足两插头和三插头的电器使用。

注意:请勿将水滴落入电源插孔内;
请勿使用超出960W额定功率的电器;
请勿外接排插板使用。

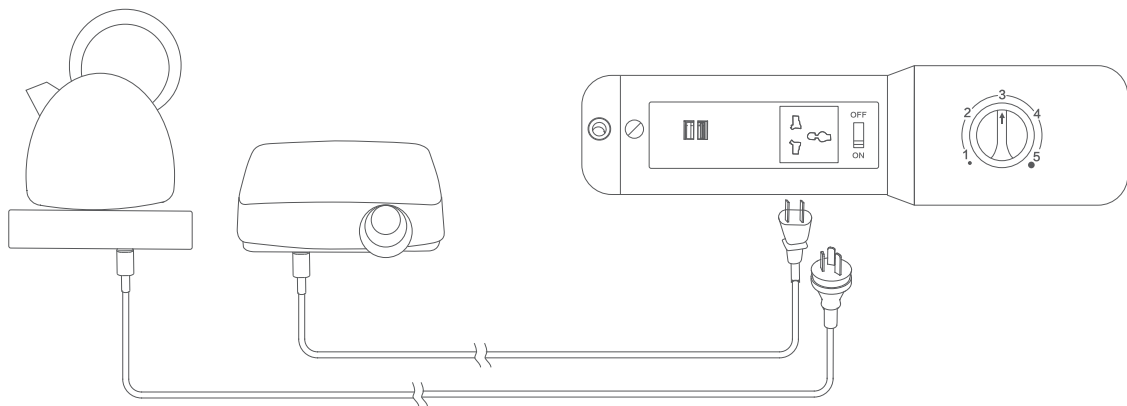

MULTI PROTECTIONS / 多重保护:

| | | | | | |
|-----------------------------|--|---|------------------------------------|--------------------------------|---|
| Overload Protection 过载保护 | 5000 times of plugging test 5000次插拔 | Shell with 750°C flame retardant 外壳750°C阻燃 | Double acting safety door 双动安全门 | Hidden warning light 隐藏式提示灯 | New national standard sockets 新国标组合孔 |
|-----------------------------|--|---|------------------------------------|--------------------------------|---|

■ WIRELESS CHARGING / 无线充电装置

Wireless charger only works for devices that are equipped with wireless charging and meet the Qi standard.
无线充电装置只适用于配备无线充电功能的设备并且符合Qi协议。

NOTE / 注意事项

1. Wireless charging is enabled once the table has been plugged in.
2. Please put the device to the center of the wireless charging area.
3. Make sure there is no metal barrier between the charger and the phone to avoid overheating.
4. If the charging surface is overheated, please remove it and stop charging.
5. The wireless charger and USB charger should not be used at the same time, otherwise the USB charger won't be able to work.

1. 插入电源后,即可开启无线充电功能。
2. 请将设备放在无线充电区域的中央。
3. 确保充电器和手机之间没有金属屏障,避免过热。
4. 如果充电表面过热,请取出设备并停止充电。
5. 无线充电和USB充电不能同时使用,否则USB充电将无法工作。

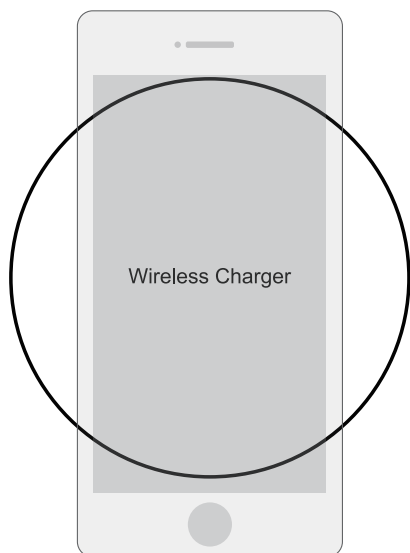

| | |
|-------------------------|-----------------|
| Voltage / 输入电压 | 12V Input/12V输入 |
| Output / 输出功率 | 10W |
| Sensing Distance / 感应距离 | ≤ 4mm |
| Work Frequency / 工作频率 | 105K-205K Hz |
| Work Temperature / 工作温度 | 14°F-149°F |
| Work Humidity / 工作湿度 | 10%RH-75%RH |

DAILY MAINTENANCE/日常保养与维护

CLEANING / 清洁

Clean the Smart Coffee Table regularly to avoid dust accumulation. Wipe the surface of the table with the microfiber cloth. Do not store expired food in the drawers.

1. Before cleaning the Smart Coffee Table, please make sure to turn off the power and remove the plug.
2. Please do not forcefully disassemble this table, as it may cause damage.
3. Clean the unit with a soft cloth and neutral detergent. Dry the unit with a clean and soft cloth.
4. Clean the shell gently to avoid deformation or short circuit caused by the water flowing into the device through the mesh.
5. Inspect the unit after cleaning. Do not use if any damage is found.
6. Make sure the table is completely dry before powering on.

NOTE: Be sure to clean the door seal thoroughly to ensure a long lasting period and preserve power consumption.

定期清理冰箱抽屉，不要在抽屉里存放过期的食物。

1. 清洁前先拔掉插头。
2. 请勿用力拆卸本机，否则可能造成损坏。
3. 用软布和中性洗涤剂清洁设备。用干净柔软的布擦干设备。
4. 小心清洗外壳，避免水通过网孔流入设备而使外壳变形或短路。
5. 清洗后检查设备。如果发现有任何损坏，请勿使用。
6. 开机前确保设备完全干燥。

注意：一定要彻底清洁门封条。干净的门封胶条可以有较好的密封效果和延长使用寿命，并能避免消耗不必要的电力。

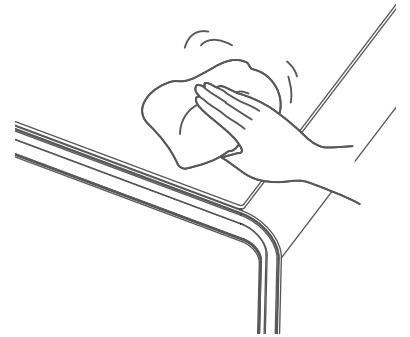

NOTE / 注意事项

In order to prevent leakage accident, do not spray water to wash the table. Please use dry cloth to clean the power socket, knob, plug and USB socket.

In order to prevent damage to the unit, please do not use following material to clean the table:

1. Acidic or slightly alkaline kitchen cleaners.
2. Similar powdered detergent products.
3. Chemicals such as benzene, sodium bicarbonate, alcohol, carious acids, petroleum.
4. Hard brush, abrasive sponge brush.
5. Hot water.

Due to the substantial weight of this table, please be cautious and avoid any scratch or damage to your floor when attempting to move the table for either cleaning or maintenance. Always keep the tempered glass top upright while doing so.

Please do not use hot water to clean the inside of the drawers including the glass shelves, partition panels or PET trays. Drastic temperature differences might cause fracture, breakage or explosion of the above, resulting in personal injury and property loss.

Please do not touch the inside of the drawers with wet hands while cleaning. Do not reach your hands underneath the bottom of the table, as the metal components might accidentally cause scratch or cut.

为了防止漏电事故，清洁时不要用水喷淋冲洗冰箱茶几。请使用干抹布清洁后面的电源插口、旋钮和开关等。

为了防止损坏冰箱茶几，清洁时不要使用以下物质：

1. 酸性或者弱碱性的厨房清洗剂。
2. 类似研磨粉等粉状洗涤用品。
3. 苯、碳酸氢钠、酒精、各种酸、石油等。
4. 硬刷子、研磨性海绵刷等。
5. 热开水。

冰箱茶几很重，当移动产品进行清洁和维修时，请保护好地面。移动时要保持冰箱茶几台面玻璃朝上，不要摇晃移动，以免误伤地板。清洁时，请勿用热水来清洗冰冷的玻璃隔板和塑料小托盘，防止因温度的急剧变化而导致玻璃破裂，造成人身伤害和财产损失。

在清洁过程中，请勿用湿手触及到冰箱茶几内部表面，也不要将手伸到冰箱茶几底部，底部金属边角可能会造成划伤。

■ DISASSEMBLY AND CLEANING OF THE REFRIGERATOR DRAWER / 冷藏保鲜抽屉的拆卸清洁

Before dismantling the refrigerator drawer, please take out the PET tray, drawer partition and all items inside from the refrigerator. Fully pull the door and the drawer, lift up the whole drawer and pull out the sets. You can use water to wash the drawer, PET tray, partition, and then use soft cloth to dry them.

冷藏抽屉拆卸前请取出塑料小托盘、抽屉隔板，清空抽屉内的物品门及里面的大抽屉一起向外拉动至不能拉动为止，然后将整套抽屉外侧向上抬起并稍微向外拉一点，即可将抽屉抬起取出。
可用水冲洗抽屉、塑料小托盘、抽屉隔板，然后用干软布擦拭干净。

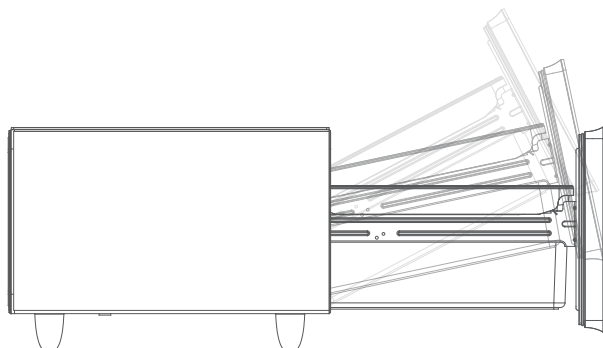
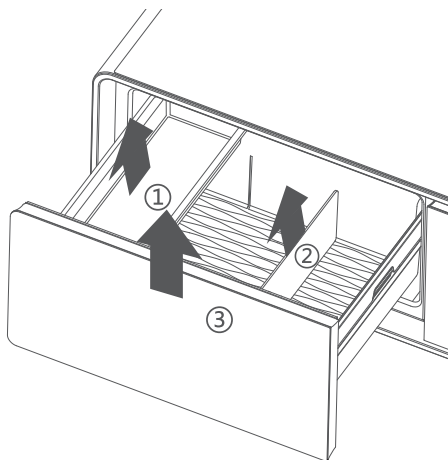

■ DEFROSTING / 除霜

The refrigerator can defrost automatically, The defrosting water flows out to the water tray at the back of the table through the bottom back of the water tank. The water will be evaporated naturally by the heat of the compressor.

冷藏室可自动除霜，化霜水通过背部下端接水槽再由出水孔流出至冰箱茶几后部的接水盘，并利用压缩机热量自然蒸发。

■ DOOR SEAL CLEANING / 门封条的清洁

The doors and door seals of smart coffee table can become dirty and easily lead to aging and damage. This can cause the door to not close properly and result in air leakage, so it is important to keep them clean. When cleaning the door seals, it is necessary to use clean water and wipe them dry with a dry cloth.

冰箱茶几的门及门封条变脏后容易引起老化、损坏，造成门体无法正常关闭并且会有冷气泄露的现象，所以必须保证其清洁。清洁门封条时，必须使用清水清洁，并用干布擦净。

■ SAFETY INSPECTION AFTER CLEANING / 清洁后的安全检查

1. Please check if the power plug is completely inserted into the socket.
2. Please check if the power cable has scratches.
3. Please check if the power plug has abnormal heating condition.
4. Please check if the power base and USB has foreign object or liquid left.

1. 电源线是否完全插入插座和冰箱茶几；
2. 电源线是否有裂痕以及擦伤；
3. 电源线插头有没有异常发热情况；
4. 电源、充电接口内是否残留异物和液体。

TRANSPORTATION AND OUTAGE / 搬运和停用

■ TRANSPORTATION / 冰箱茶几的搬运

1. Unplug the product.
2. Take out all the items inside the Smart Coffee Table.
3. Use adhesive tape to secure the partition and PET tray inside the Smart Coffee Table.
4. Close the drawer and use adhesive tape to secure it.

1. 拔下电源插头, 切断电源。
2. 取出冰箱内的所有物品。
3. 用胶带固定冷藏室的隔板和塑料托盘等活动部件。
4. 关紧冰箱门并用胶带固定。



Do not lay down the refrigerator at any time.
To avoid affecting the refrigerate system, The maximum inclination angle should be less than 45° during delivery.

任何时候都不可以将冰箱茶几放倒。
搬运冰箱茶几时, 最大倾斜角度不能超过45度, (与垂直方向之间的夹角), 以免造成制冷系统故障, 影响正常使用。

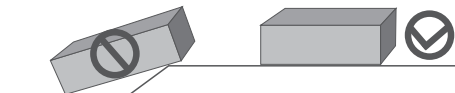
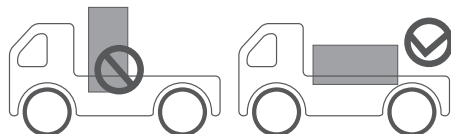
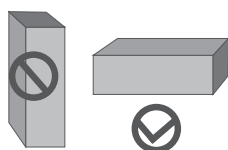

■ POWER OUTAGE/ 停电

Even in summer, the temperature in the refrigerator can keep 1-2 hours after power outage.
Please do not put more food into the unit and do not open the door when power off. You can put some ice with a container in the drawer if you had known about the outage.

停电后, 即使是夏季, 1-2小时之内, 将不会影响冰箱内部的温度。
停电后, 不要再放入新的食品, 尽量不要开门。如果事先知道要停电, 可以放入一些冰块, 用不漏水的容器盛好, 放在抽屉内。



An increase in the temperature of the refrigerator due to power outages or other failures can shorten the shelf life of food and affect its quality.
由于断电或者其它故障引起的冷藏室温度上升, 会缩短食品的存储期限以及降低其食用的质量。

■ POWER OFF/ 停止使用

If the refrigerator will not be used for a long period of time, please unplug and cut off the power, and clean the unit.
Please keep the door open to avoid any bad odor created by the food debris.

如果冰箱茶几停止使用较长的时间, 应拔下电源插头, 切断电源, 并照前面所述的方法清洁冰箱茶几。
冰箱停止使用时应敞开冰箱门, 以防冰箱茶几内食品残渣产生不良气味。



After unplugging the power cord, please wait for at least five minutes before plugging it back on. To extend the lifespan of the product, avoid opening and closing the drawers too frequently.
If you want to dispose of this item, please properly disposed of or handed over to professionals for disposal. Do not dispose of it casually to avoid harm to the environment or other hazards.

拔下电源后, 至少保持间隔五分钟, 才能再次插电, 一般情况下不要频繁开启和关闭冰箱茶几, 以免影响产品的使用寿命。
器具报废后, 应妥善处理或者交给专业人士处理, 不要随便丢弃, 以免对环境造成危害或引发其他危险。

■ GO OUT FOR HOLIDAY/外出度假时

1. Cut off the power
2. Take out all the food inside the unit.
3. Clean the unit properly.

1. 切断电源。
2. 取出食品。
3. 适当地清洁冰箱茶几。

NON-FAILURE / 非故障现象

| | |
|----|---|
| 1 | <p>Foggy condensation on the surface: In rainy season with high humidity, condensation may occur on the surface of the refrigerator, which is not a malfunction, please dry it with a clean cloth.</p> <p>冰箱茶几外表面出现雾状凝露：在湿度非常大的季节，如雨季等，可能在箱外发生凝露现象，这和冰水注入玻璃杯使其外侧发生凝露现象相同，并非故障。可用干布把它抹干。</p> |
| 2 | <p>"hissing" sound occur :This is the flow water sound of the refrigerate, which is normal phenomenon.</p> <p>冰箱茶几有“滋滋”的流水声：这是制冷剂的流动声，属正常现象。</p> |
| 3 | <p>Compressor can not be started: The voltage is too low, please stop powering on the refrigerator and wait the voltage to get back to normal.</p> <p>电压过低，压缩机不启动：立即停机等电压正常后再启动。</p> |
| 4 | <p>Long boot time: In summer, it is normal to start the device for a long time due to the indoor high temperature.</p> <p>开机时间较长：夏季，由于环境温度较高，开机时间较长为正常现象。</p> |
| 5 | <p>"Papa" sound: It is caused by thermal expansion and contraction of the inner tank and refrigeration pipe.</p> <p>冰箱茶几在工作时有轻微的“啪啪”声：由于内胆和制冷管路热胀冷缩而引起。</p> |
| 6 | <p>"humming" sound: When the refrigerator is working, the compressor will produce "humming" sound. If the device is not placed on a flat surface., vibration and noise will occur, just adjust the feet of the device according to the manual.</p> <p>冰箱茶几有“嗡嗡”的振动声：冰箱茶几工作时，压缩机会发出轻微的“嗡嗡”声。如果冰箱茶几没有放置平稳，也会产生振动和噪音，请按照说明书相关内容把冰箱茶几底脚调整平稳即可。</p> |
| 7 | <p>Wireless charger can not work: The charger of mobile phone can not meet the standard. Please make sure the phone charger meet the QI standard.</p> <p>无线充电器无法充电：有可能是充电线圈不匹配，请确保智能设备符合QI协议的充电标准。</p> |
| 8 | <p>Delay charging of the wireless charger: Please check the phone to make sure it places on the right area and remove the shell of the phone.</p> <p>无线充电器充电延迟：有可能是智能设备偏离充电区域导致，请确保居中放置，并且智能设备和充电台面之间没有异物。</p> |
| 9 | <p>110 V plug can not work: Please make sure there is no water or foreign object in the socket. Check the refrigerator whether is connected properly and whether the switch on the right socket is turning on or not. If still doesn't work, please contact the after-sales service.</p> <p>110V电源没有电：请确保电源插孔中没有水滴或异物，检查冰箱茶几是否通电，再确定右边的开关呈开启状态，如还是没有电，请联系售后查看原因。</p> |
| 10 | <p>USB can no longer work: Check the refrigerator whether is connected properly and whether the switch on the right socket is turning on or not. If still doesn't work, please contact the after-sales service.</p> <p>USB无法充电：检查冰箱茶几是否通电，再确定右边的开关呈开启状态，如还是无法使用，请联系售后查看原因。</p> |
| 11 | <p>Refrigerator bottom is wet: Please check if the outlet hole is blocked.</p> <p>冷藏室内胆底部潮湿或有积水：检查接水槽上的出水孔是否堵塞。</p> |
| 12 | <p>The compressor runs continuously for a long time: Please check if the setting temperature is too low, the door of refrigerator is keeping left opening for a long time, hot food has put inside, the refrigerator is exposed to direct sunlight or there is too much food in it to influence the air circulation.</p> <p>压缩机长时间运转不停：温度设置是否过低。冰箱茶几门是否长时间打开。放入冰箱茶几内的食物是否过热。冰箱茶几是否受阳光直射或附近有高温热源。是否食物摆放过密，影响冰箱茶几内冷气流通。</p> |

TROUBLE SHOOTING / 故障排除

| Fault / 故障现象 | Causes / 产生原因 | Solutions / 排除方法 |
|---|--|--|
| Power light is on, compressor is working but making "humming" sound. 电源指示灯亮, 压缩机不正常工作, 只有嗡嗡声 | Power Voltage is lower than 90V. 电源电压低于90V | Stop powering on the refrigerator and wait the voltage to get back to normal. 立即停机等电压正常后再启动 |
| Compressor starts but stops after about one minute, and then starts and stops ongoing. 压缩机启动, 在一分钟左右时间内停下, 等几分钟又重新启动, 如此反复 | Power voltage is higher than 120V 电源电压高于上限120V | |
| Compressor runs for a long time, but evaporator surface is frost free. 压缩机运转时间很长, 而蒸发器表面无霜 | Leak 管路漏气制冷剂泄漏 | Professional inspection is required. 需送维修部门检修 |
| | Blockage 管路堵塞 | Professional inspection is required. 需送维修部门检修 |
| There is frost on the surface but the compressor is keep working. 蒸发器表面有霜, 而压缩机运转不停 | Too much frost on evaporator. 蒸发器结霜太厚 | Defrost. 及时化霜 |
| | Opening the drawers for a long time. 开门次数太多时间太长 | Do not open drawers frequently. 尽量减少开门次数 |
| | Drawers are filled with too many items. 食品放得太多 | Remove some of the items inside. 适当取出部分食品 |
| | Bad heat dissipation of condenser 冷凝器散热不佳 | Move to a ventilated area. 选择适当的空气流通场所 |
| | Thermostat is failing or sensor is missing. 温控器失灵或感温管脱离蒸发器 | Professional inspection is required. 需送维修部门检修 |
| The refrigerator doesn't work and refrigerated. 冰箱茶几不工作, 不制冷 | Fuse is blown and the power light is off. 保险丝熔断(电源指示灯不亮) | Replace fuse. 更换保险丝 |
| | Input controlling circuit has fault and the power light is off. 输入控制线路故障(电源指示灯不亮) | Professional inspection is required. 需送维修部门检修 |
| Excessive noise 噪音过响 | Machine places uneven. 箱体放置不平 | Adjust the feet of the refrigerator. 垫平底脚 |
| | Inner fastener is loose. 箱体紧固件松动 | Secure the fastener. 紧固松动件 |
| | Collision between pipes. 管路之间有相碰现象 | Separate the pipes. 将管子分开 |
| It can refrigerate but when touch the surface, there is a slightly hemp and the electroprobe test with a light bright. 制冷, 但手触及箱体感觉有微麻电感, 用电笔测量有微亮 | Induced electricity is leaking. 感应电流漏电或受了潮 | Check the earthing conductor. 检查接地是否良好, 接妥地线 |