

Shade N' Shelters

Owner's Manual

Shorewood

10' x 10' Arched Pergola

Model Number: SHOR-PERG-2



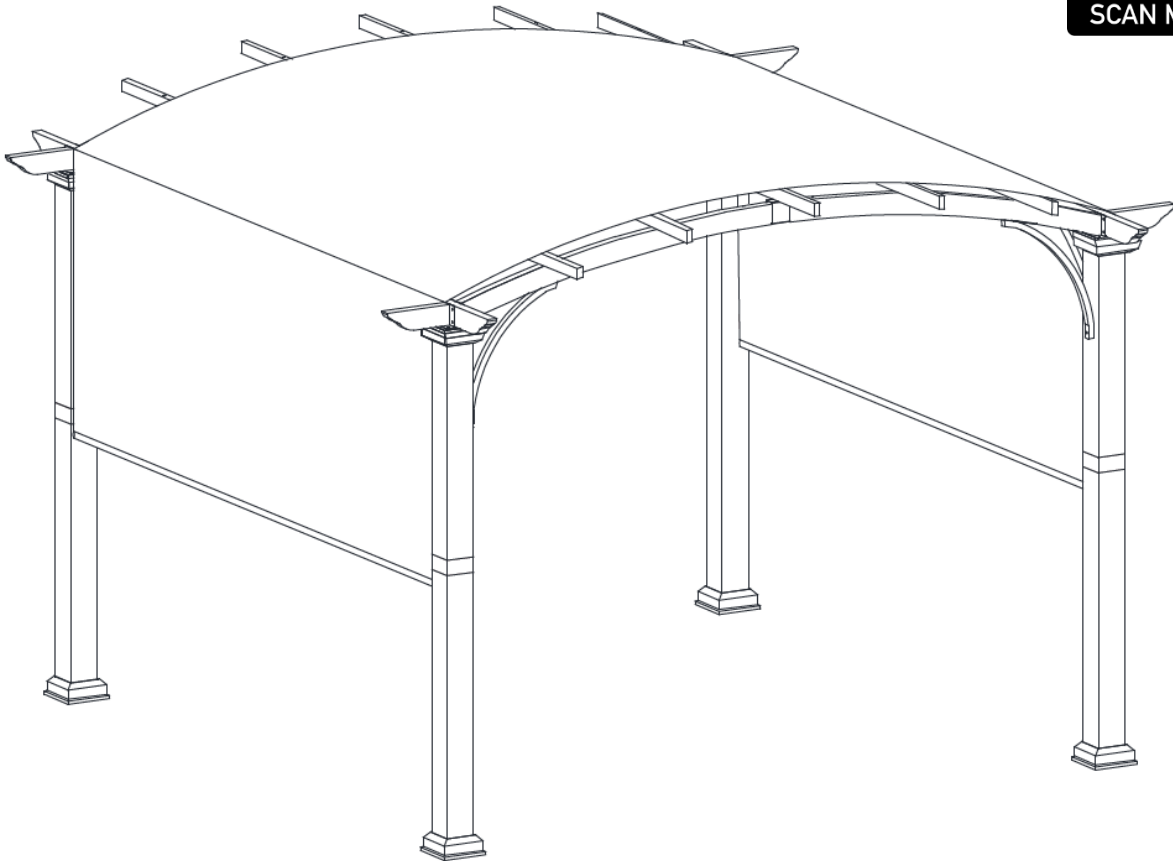







Scan For Video
Assembly Instructions!







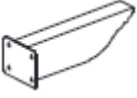



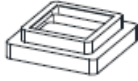

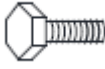

Note: This pergola frame is designed to be used as a permanent fixture. Remove canopy when not in use or during high winds, rain or snow.

Parts List

Shorewood 10' x 10' Arched Pergola

Letter	Illustration	Description	Qty.
A		Corner Post	4
B		Curved Top Beam	4
C		Outside Lintel	4
D1		Inside Lintel	10
D2		Inside Lintel Connector	5
E		Cross Beam Center Connector Plate	4
F1		Beam Connector	4
F2		Ferrule	5
G		Short Lintel End	4
H		Corner Post Cover	4
I1		Curved Corner Post Brace	4

Letter	Illustration	Description	Qty.
I2		Curved Corner Post Brace	4
J		Base Cover	4
K		Base Plate	4
L1		Short Canopy Support Bar	2
L2		Long Canopy Support Bar	2
M		Canopy	1
N		M6 x 15 mm Bolt	46
O		M6 x 20 mm Bolt	16
P		M6 x 35 mm Bolt	16
Q		M6 x 45 mm Bolt	26
R		M6 Washer	56
S		Plastic Washer	64

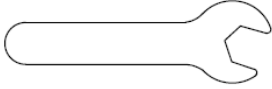
Letter	Illustration	Description	Qty.
T		Nut	16
U		M6 Bolt Cap	16
V		Ground Stake	16
W		M6 Open Wrench	2

Assembly Instructions

Shorewood 10' x 10' Arched Pergola

Note: For video instructions please visit:

<https://shadenshelters.com/10x10-shorewood-pergola>

Important:

- Read all the instructions before assembly. Failure to do so may result in faulty assembly and potential injury.
- Before assembling the product, remove all protective materials, hardware kit(s), and identify all parts packed in the carton are present. (Note: If any part is missing or damaged, do not attempt to assemble). Contact Shade N' Shelters Customer Support. See page 14.
- Assemble on a stable level surface to avoid damage to gazebo and possible injury.
- Two people are required to assemble this product.
- Pergola dimensions are measured from roof corner to roof corner.

WARNING: DO NOT TIGHTEN BOLTS UNTIL NOTED AFTER EACH STEP!

Step 1A: Insert the Corner Posts (A) into the Base Covers (J), then attach the Base Plates (K) to the Corner Posts (A) using Bolts (N) and Washers (R). **Tighten Bolts.** See Figure 1-1.

Step 1B: Place the Corner Post Cover (H) onto the top of the Corner Posts (A). See Figure 1-2. Do not attached with Bolts at this point.

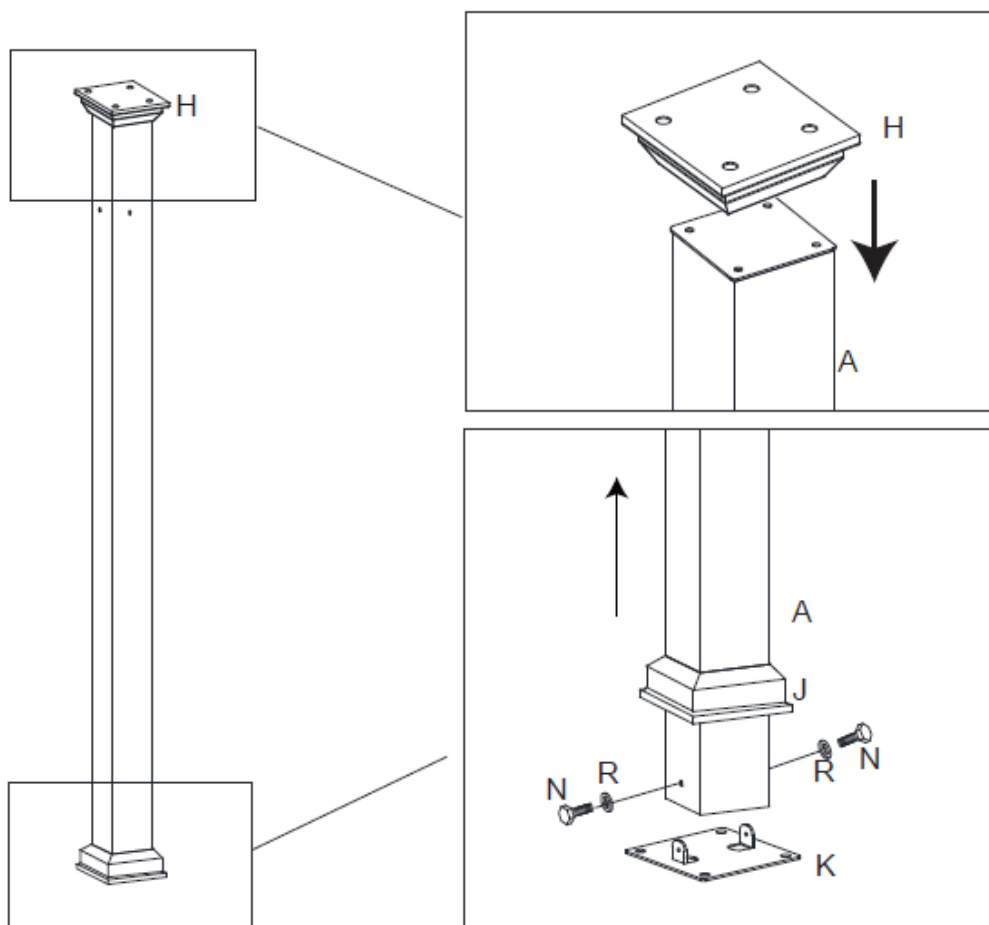

Figure 1-2

Figure 1-1

Step 2A: Insert the Cross Beam Center Connector Plate (E) into the Outside Lintel (C), attach using Bolts (N) and Plastic Washers (S). See Figure 2-1.

Step 2B: Insert the Outside Lintel (C) and Cross Beam Center Connector Plate (E) into Beam Connector (F1). See Figure 2-2.

Step 2C: Attach the opposite Outside Lintel (C) to the Cross Beam Center Connector Plate (E) with Bolts (N) and Plastic Washers (S). **Tighten all Bolts.** See Figure 2-3.

Step 2D: Repeat Step 2A to Step 2C for remaining Outside Lintels (C). **Tighten all Bolts.** See Figure 2-4.

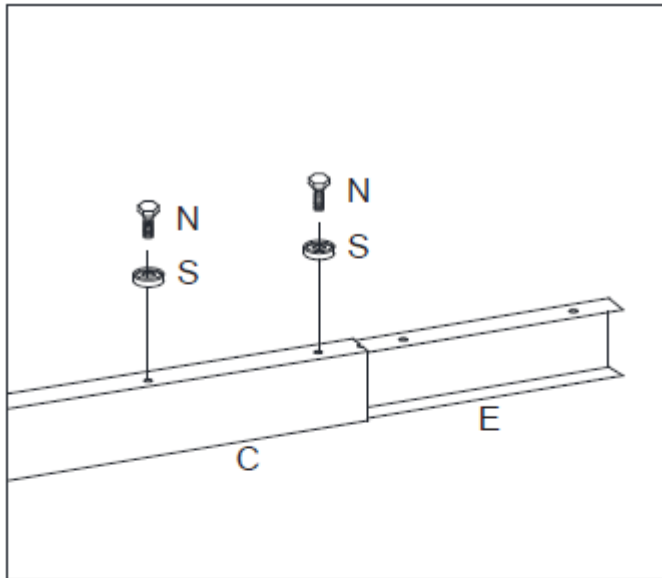

Figure 2-1

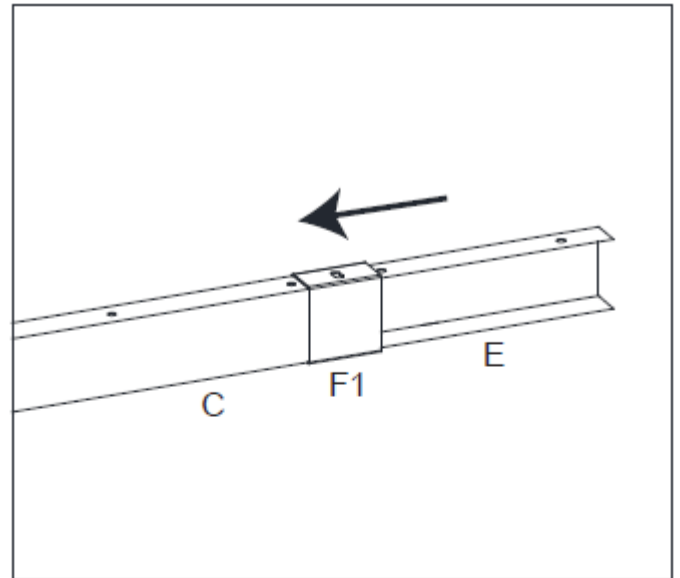

Figure 2-2

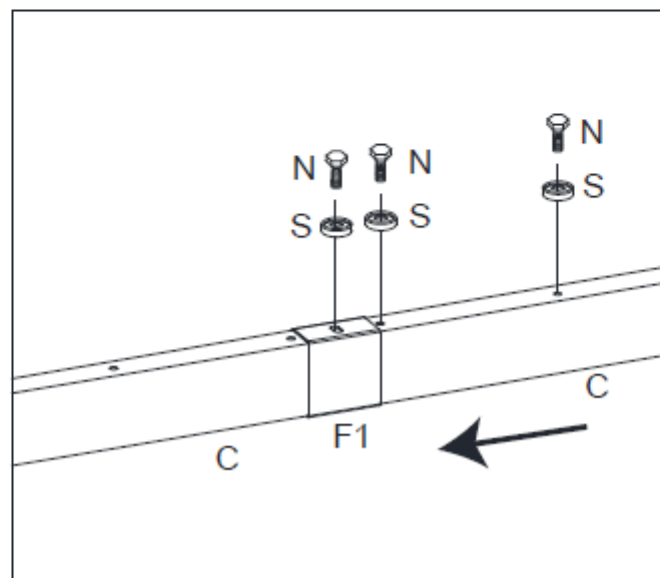

Figure 2-3

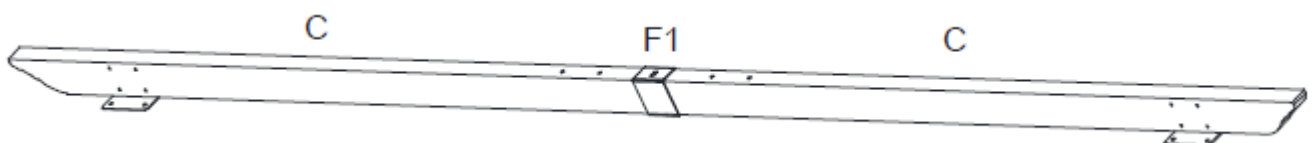

Figure 2-4

Note: For Step 3 the bolts holes on the corner posts must face the bolt holes on the opposite corner post.

Step 3A: Attach the Assembled Outside Lintels (C) to the Corner Post Covers (H) with Bolts (O) and Plastic Washers (S). **Tighten Bolts.** See Figure 3-1.

Step 3B: Repeat for opposite side. **Tighten Bolts.** See Figure 3-2.

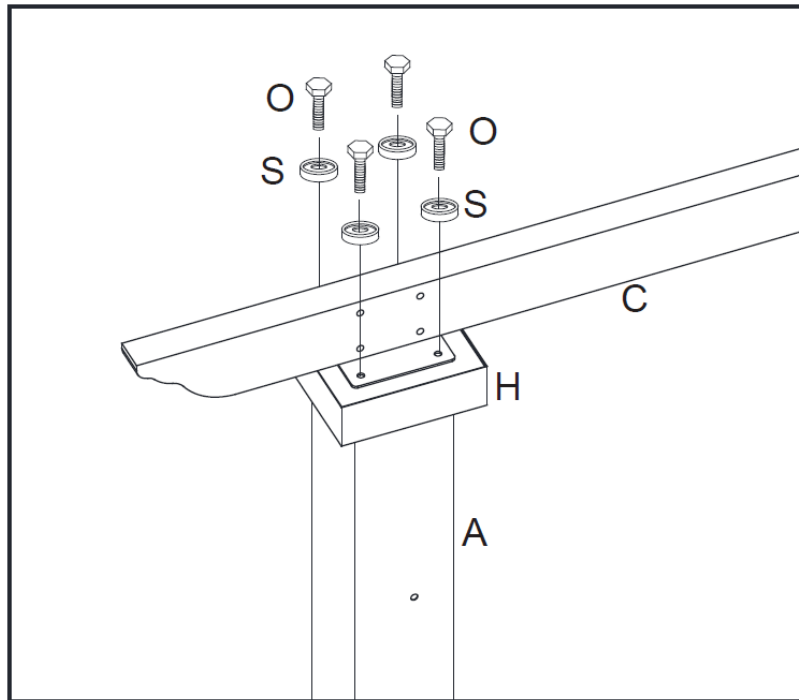

Figure 3-1

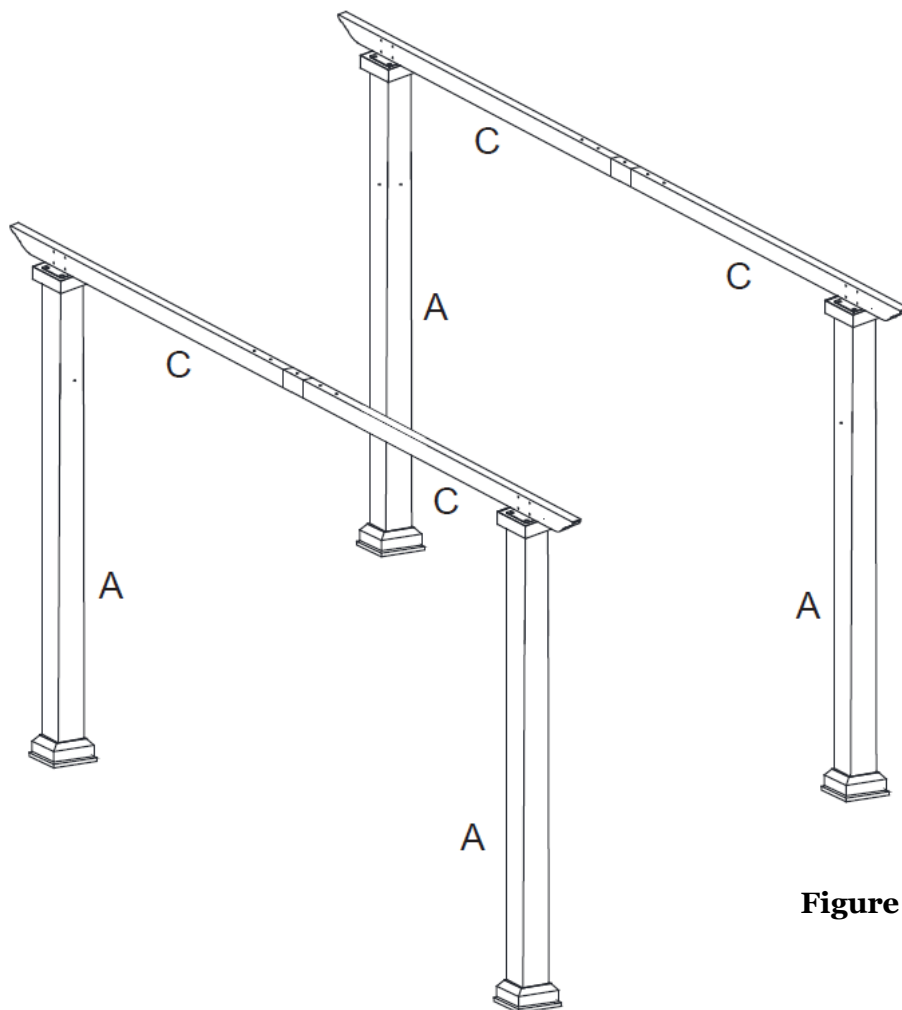

Figure 3-2

Step 4A: Insert Cross Beam Center Connector Plate (E) into the Curved Top Beam (B), attach using Bolts (N) and Plastic Washers (S). See Figure 4-1.

Step 4B: Insert the Curved Top Beam (B) and Cross Beam Center Connector Plate (E) into Beam Connector (F1). See Figure 4-2.

Step 4C: Attach the opposite Curved Top Beam (B) to the Cross Beam Center Connector Plate (E) with Bolts (N) and Plastic Washers (S). **Tighten Bolts.** See Figure 4-3.

Step 4D: Repeat steps 4A to 4C for remaining Curved Top Beams (B). **Tighten Bolts.** See Figure 4-4.

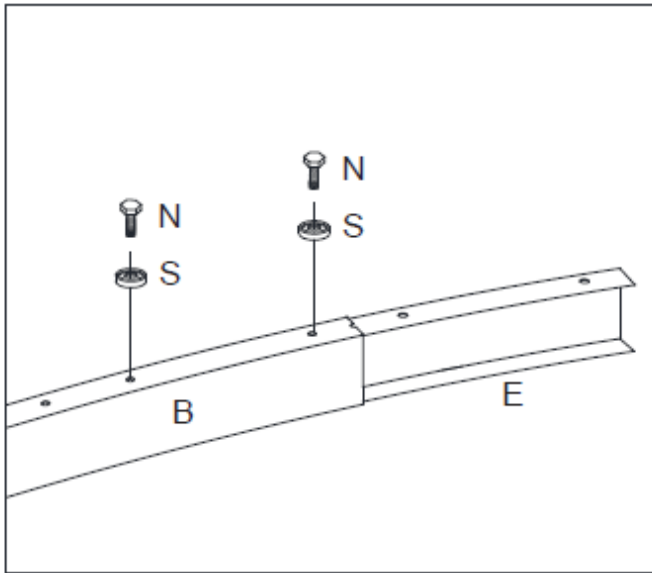

Figure 4-1

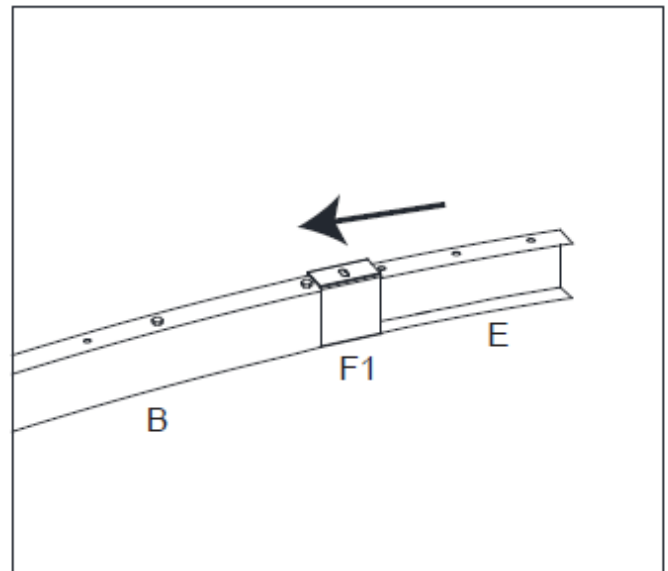

Figure 4-2

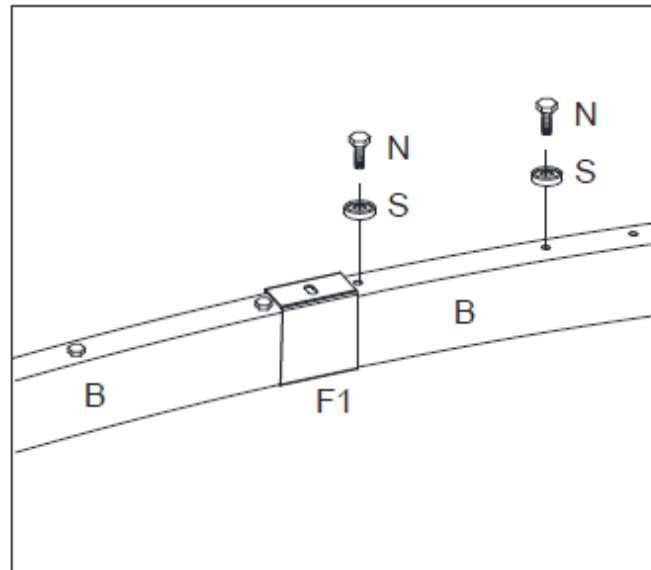

Figure 4-3

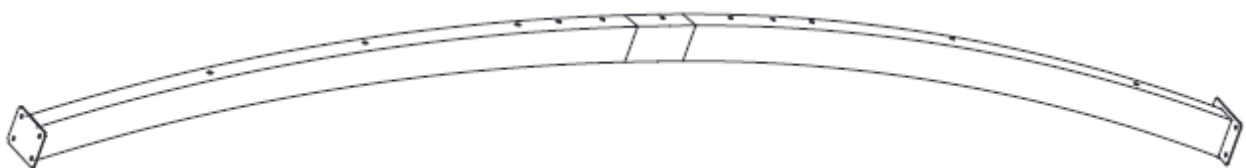

Figure 4-4

Step 5A: Connect the assembled Curved Top Beam (B) with the Short Lintel End (G) through the holes of the assembled Outside Lintel (C) using Bolts (Q), Washers (R) and Nuts (T). See Figure 5-1. Repeat for opposite side.

Step 5B: Attach Curved Corner Post Brace (I1) to the Corner Posts (A) and the Outside Lintel (C) using Bolts (P) and Washers (R). Repeat this step for attaching the Curved Corner Post Brace (I2) to the Corner Posts (A) and the Curved Top Beam (B) using Bolts (P) and Washers (R). See Figure 5-2.

Step 5C: Repeat Step 5A and 5B for remaining corners. **Tighten Bolts** and attach Bolt Caps (U). See Figure 5-3.

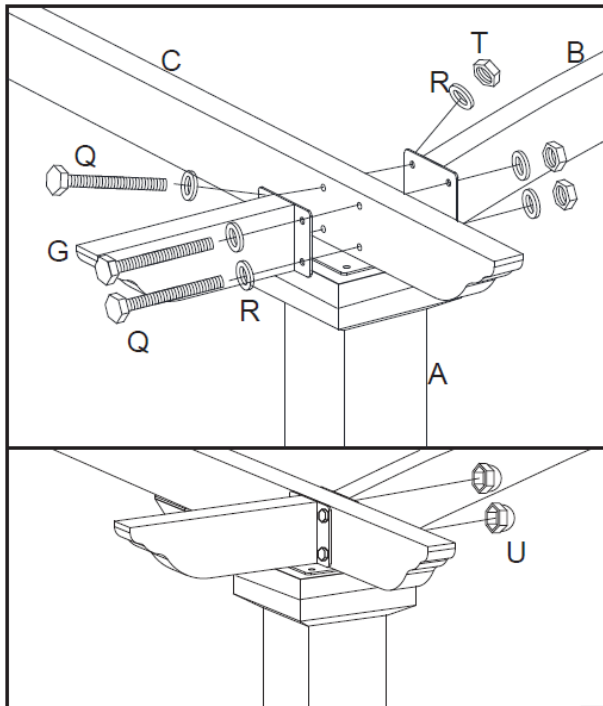

Figure 5-1

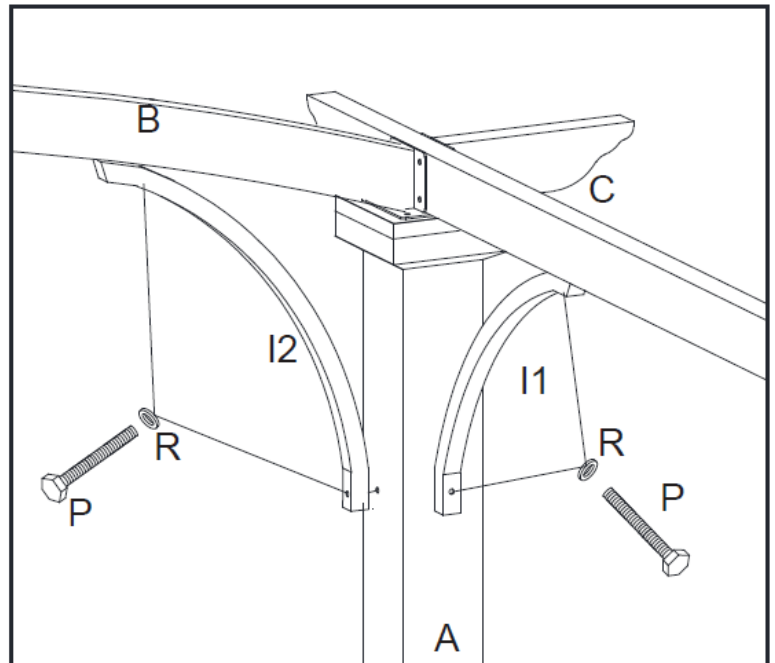

Figure 5-2

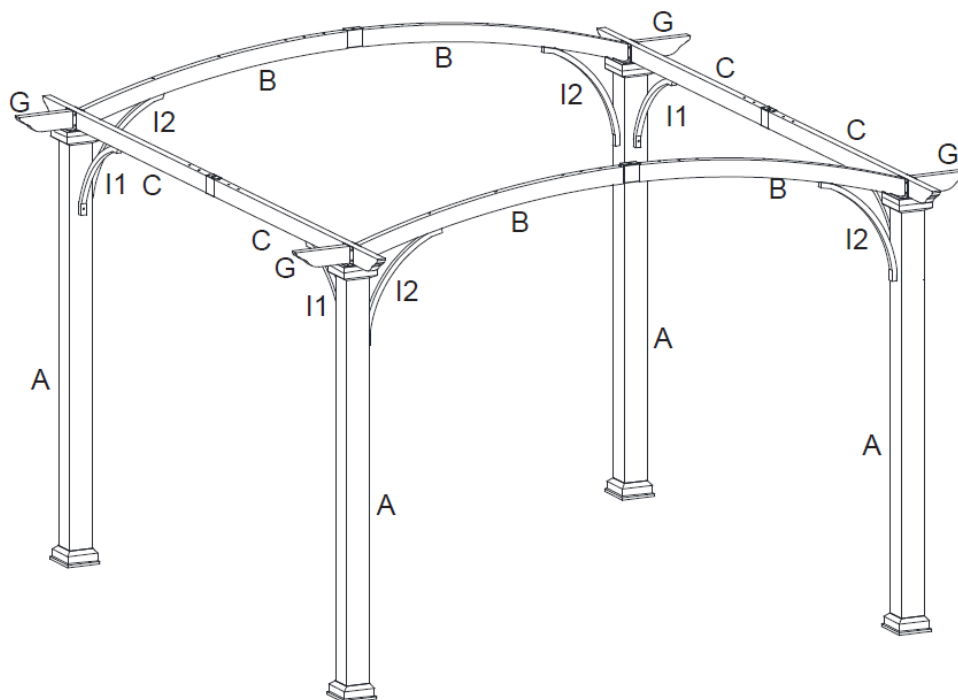

Figure 5-3

Step 6A: Attach the two Inside Lintels (D1) to the Inside Lintel Connector (D2) using Bolts (N) and Plastic Washer (S) for the end holes only. Tighten Bolts. See Figure 6-1A and Figure 6-1B.

Step 6B: Attach the Ferrule (F2) to the Inside Lintel (D1) using the Bolts (N) and Plastic Washer (S).
Tighten all Bolts. See Figure 6-2.

Step 6C: Repeat for all Inside Lintels (D1). **Tighten Bolts.** See Figure 6-3.

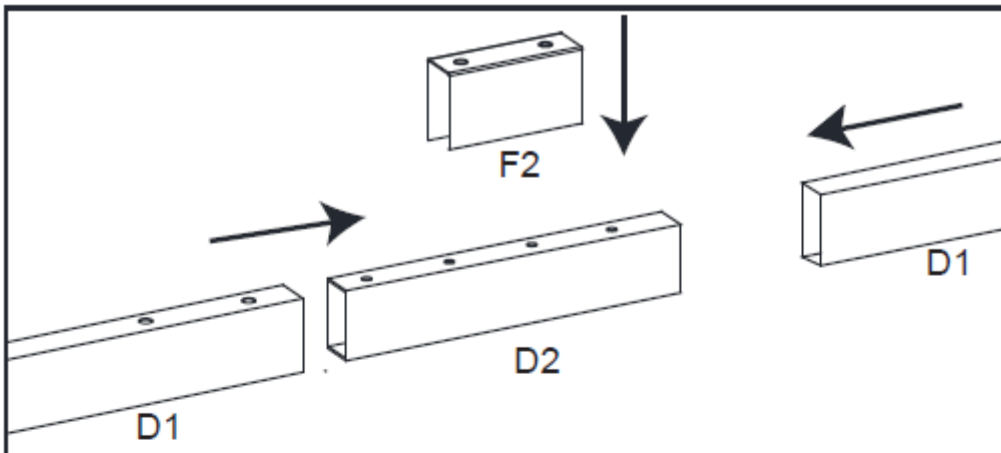

Figure 6-1A

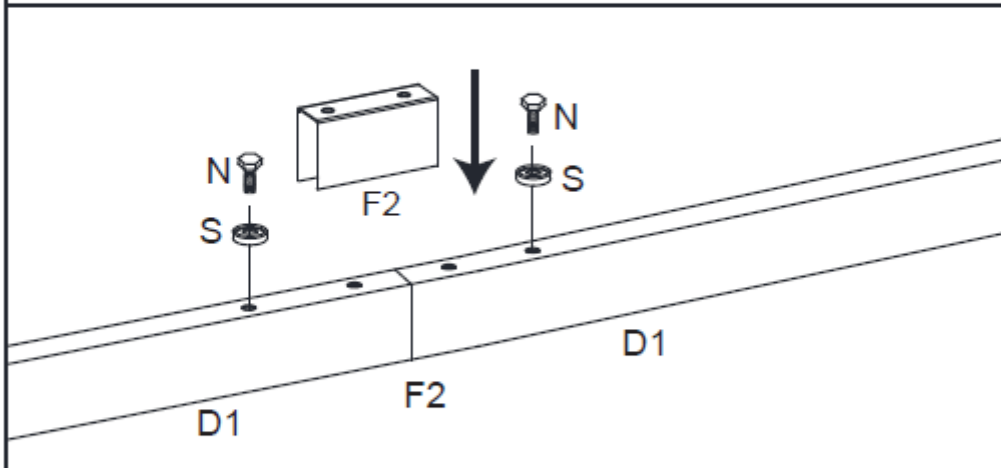

Figure 6-1B

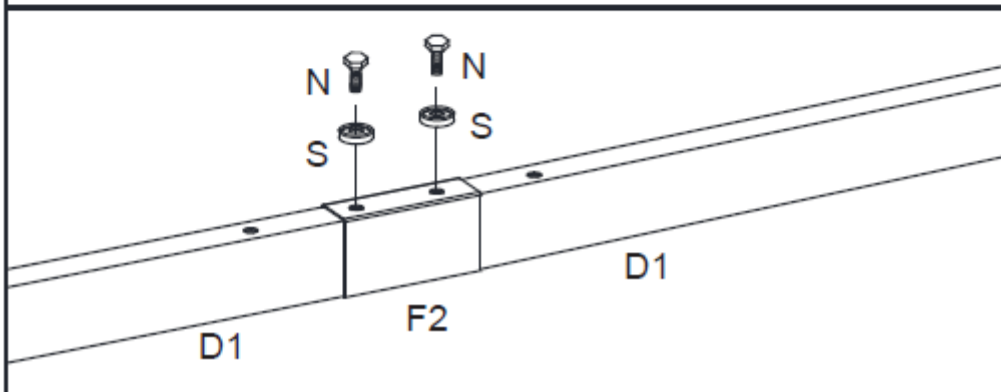

Figure 6-2

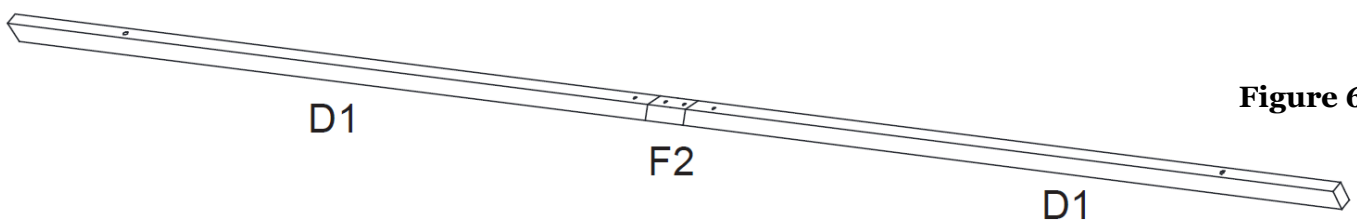

Figure 6-3

Step 7A: Attach the assembled Inside Lintels (D1) to the Curved Top Beam (B) using Bolts (Q) and Plastic Washers (S). **Tighten Bolts.** See Figure 7-1.

Step 7B: Repeat for all Inside Lintels (D1). See Figure 7-2.

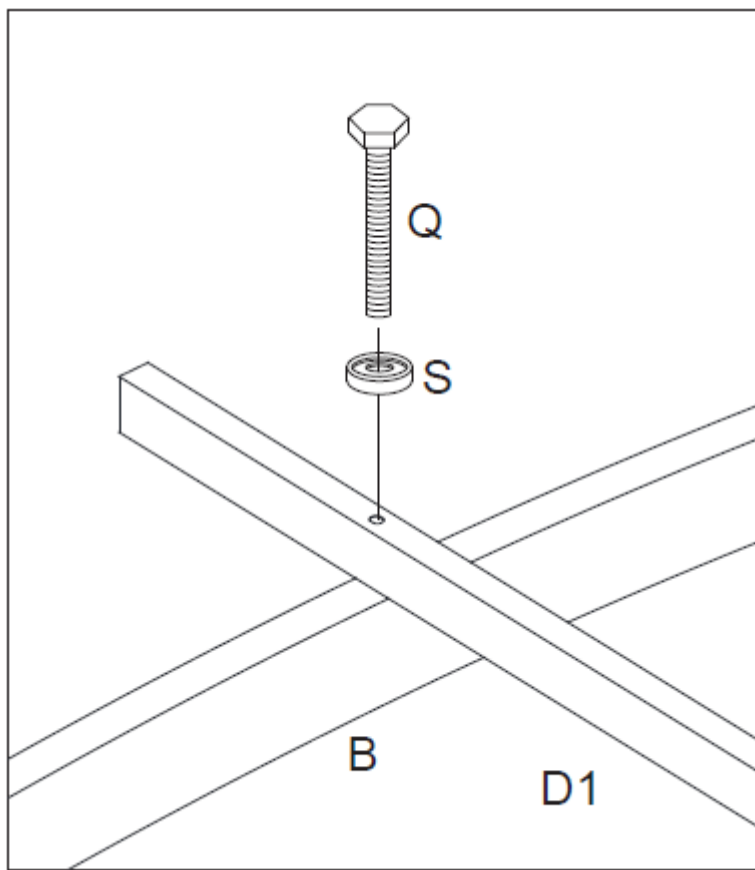

Figure 7-1

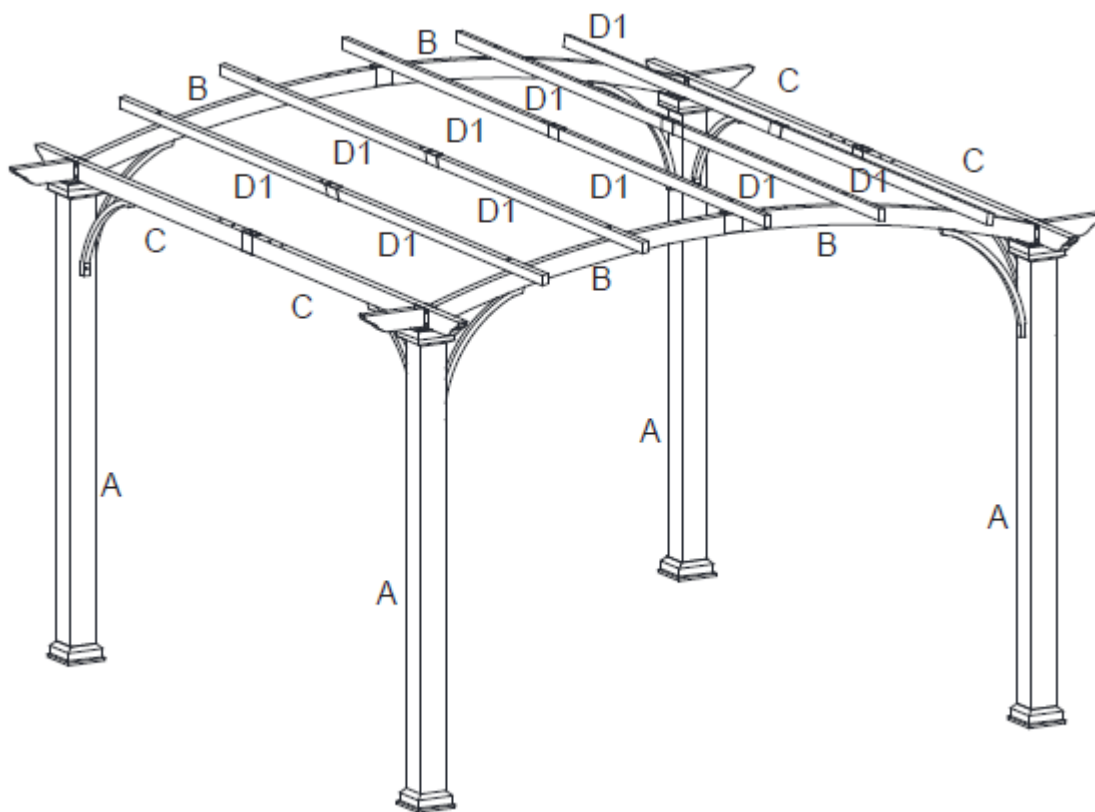

Figure 7-2

Step 8: Place the Canopy (M) on the top of the pergola. Attach the Short Canopy Support Bar (L1) to the Long Canopy Support Bar (L2). Insert the assembled tubes (L1/L2) into the hemline of the canopy. Secure the canopy to the Corner Posts with the Tie Strap. See Figure 8.

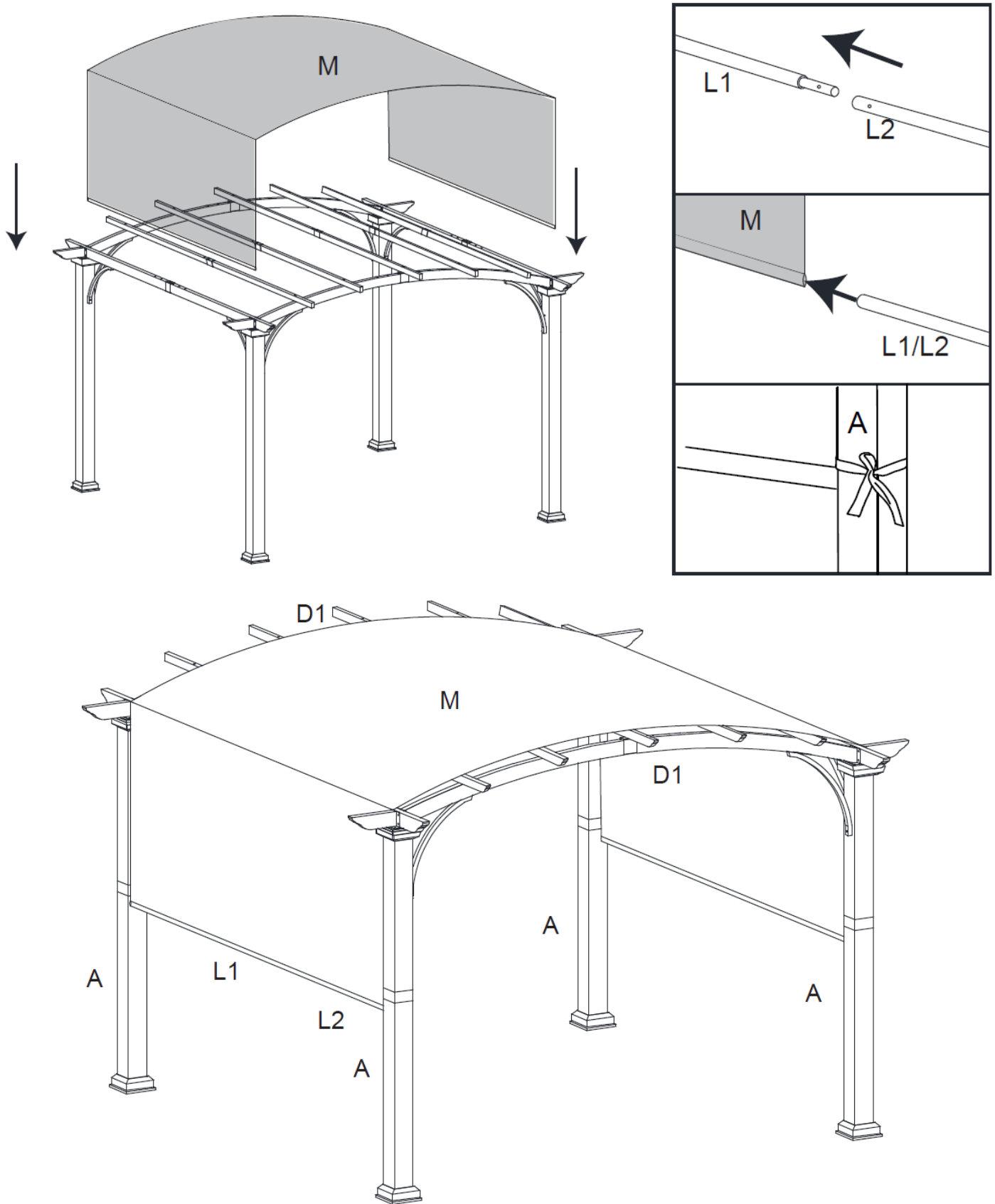

Figure 8

Step 9: Lift the Base Cover (J) and secure the assembled pergola with Ground Stake (V). See Figure 9.

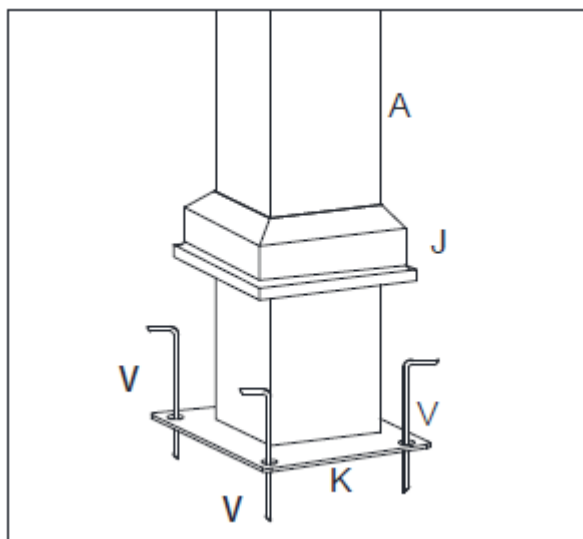
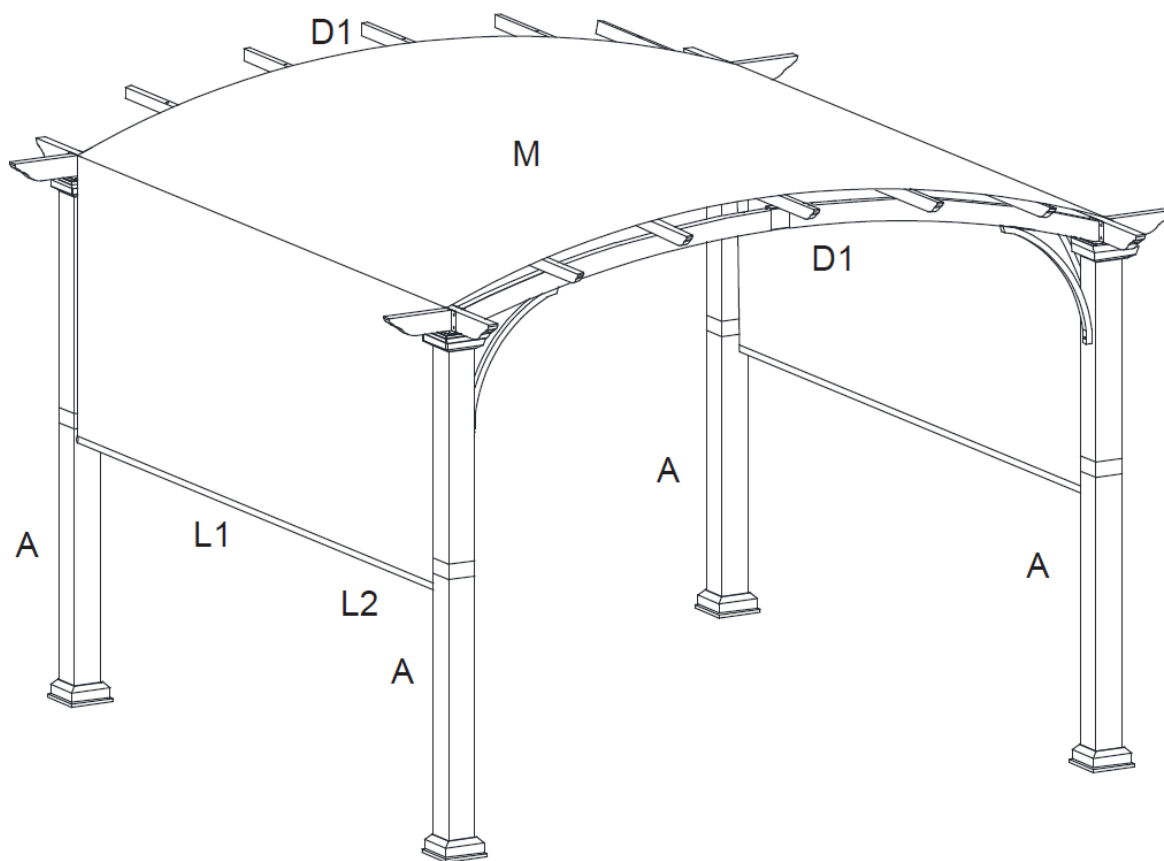

Figure 9



Note: Please see our video for additional assembly assistance:

<https://shadenshelters.com/10x10-shorewood-pergola>

Care & Maintenance

Maintain your outdoor pergola by removing the canopy and storing out of the elements when not in use, or during hazardous weather conditions (wind, rain, snow, etc.). Please visit: <https://shadenshelters.com> to purchase replacement canopy.

Frame: Clean frames with a mild soap and warm water. Do not use abrasive materials, cleaners or bleach. Rinse with clean water and dry thoroughly.

Fabric: Canopy may be cleaned by hand with a mild solution of soap and water. Rinse thoroughly and allow to drip dry. Do not use bleach or solvents on fabrics.

Warranty

You must retain the original receipt to obtain warranty service.

What is covered?

Frame: Frame is warranted against rusting for 1-year

Finish: Frame Finish is warranted against peeling, cracking or blistering for 1-year if the product has not been scratched or abrade.

Fabric: Canopy are covered by a 1-year warranty against manufacturing defects.

What is not covered?

EXCLUSIONS: Pergola use for commercial, contract, or other non-residential purposes, damage due to acts of nature, vandalism, misuse, or improper assembly are not covered. Discoloration or fading of the finish or fabrics as a result of chemicals or spills, pool water chemicals or salt water is not covered. Mildew of fabric is not covered. Corrosion and rusting of frames resulting from scratches are not covered. If within the stated warranty period this product is found to be defective in material or workmanship, the purchaser must contact the manufacturer's customer service department. The manufacturer, at its option, will repair or replace the defective parts. Proof of purchase (dated register receipt) is required for warranty claims. It remains the customer's responsibility to pay for freight and packing charges to and from the service center. Warranty is to the original purchaser and is non-transferable. Any replacement of warranted items will be in the original style and color, or similar style and color if the original is unavailable or has been discontinued.

Questions, problems, missing or damaged part? Before returning to the store call or email our Customer Service.

Customer Service Contact Information:

Hours: Monday - Friday 8:00 a.m. - 5:00 p.m. Central Time (CT)

Phone: 1-888-607-4417

Email: service@shadenshelters.com