



# Owner's Manual

## Conley

### 10' x 10' Gazebo with Awning and Bar

Model Number: CON-1010-21

SKU Number: 272-1939



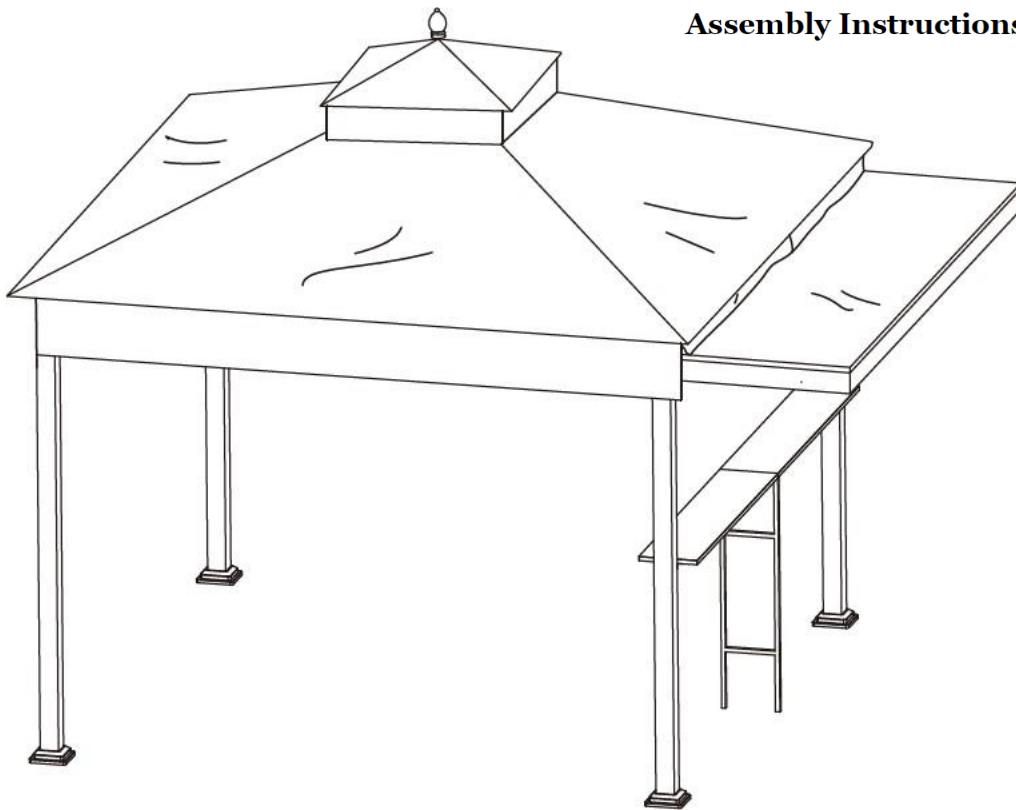

Scan For Video  
Assembly Instructions!





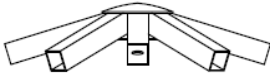
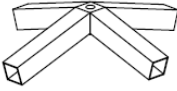
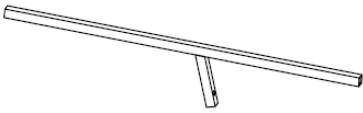



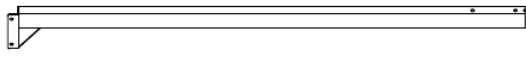
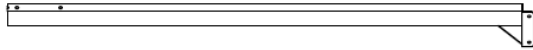
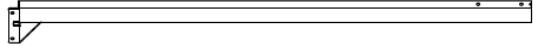
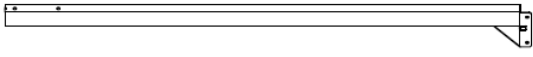

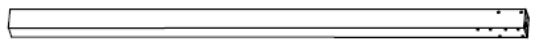

Note: This gazebo frame is designed to be used as a permanent fixture. Remove the main canopy and awning when not in use or during high winds, rain or snow.

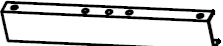

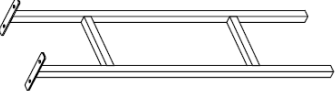
# Parts List

## 10' x 10' Gazebo with Awning and Bar

Letter	Illustration	Description	Qty.
A		Main Roof Connector	1
A1		Upper Roof Connector	1
A2		Upper Roof Support	4
A3		Finial	1
B		Main Roof Corner Support	4
B1		Main Roof Corner Support Extension	4
C		Main Roof Side Support	4
D		Cross Beam	3
D1		Cross Beam	3
D2		Cross Beam	1
D3		Cross Beam	1

Letter	Illustration	Description	Qty.
E		Corner Post	2
E1		Corner Post	1
E2		Corner Post	1
F		U-Shaped Connector	8
F1		Cross Beam Corner Plate	4
G		Cross Beam Center Connector Plate	4
H		Bar Shelf	2
H1		Bar Support Stand	1
H2		Bar Connector	2
I		Awning Frame - Left Side	1
I1		Awning Frame - Right Side	1
I2		Awning Corner Connector	2

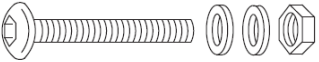
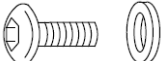
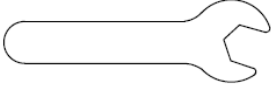
Letter	Illustration	Description	Qty.
J		Awning Frame - Left (Front and Back)	2
J1		Awning Frame - Right (Front and Back)	2
K		Awning Frame - Center	1
L		Awning Hydraulic Rod	2
M		Awning Lock	1
N		Base Plate	4
O		Base Cover	4
P		Main Roof Canopy	1
P1		Upper Roof Vent Canopy	1
Q		Awning Canopy	1
R		M6 x 15 mm Bolt with Washer	112
S		M6 x 32 mm Bolt with Nut and Washers	8

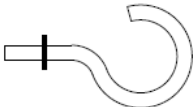
Letter	Illustration	Description	Qty.
T		M6 x 50 mm Bolt with Nut and Washers	2
U		M6 x 15mm Bolt with Washer	8
V		M6 Hex Wrench	2
W		Allen Wrench	1
X		Ground Stake	16
Y		Accessory Hook	1

# Assembly Instructions

## 10' x 10' Gazebo with Awning and Bar

Note: For video instructions please visit:

<https://shadenshelters.com/conley-gazebo-with-awning>

### Important:

- Read all the instructions before assembly. Failure to do so may result in faulty assembly and potential injury.
- Before assembling the product, remove all protective materials, hardware kit(s), and identify all parts packed in the carton are present. (Note: If any part is missing or damaged, do not attempt to assemble). Contact InSide Out Customer Support. See page 19.
- Assemble on a stable level surface to avoid damage to gazebo and possible injury.
- Two people are required to assemble this product.
- Gazebo dimensions are measured from end of corner post base covers.

**WARNING: DO NOT TIGHTEN BOLTS UNTIL NOTED AFTER EACH STEP!**

**Step 1:** Insert Corner Posts (E/E1/E2) into Base Cover (O) and raise them up. Attach Base Plate (N) to Corner Posts (E/E1/E2) using Bolt and Washer (R). See Figure 1. **Tighten Bolts.**

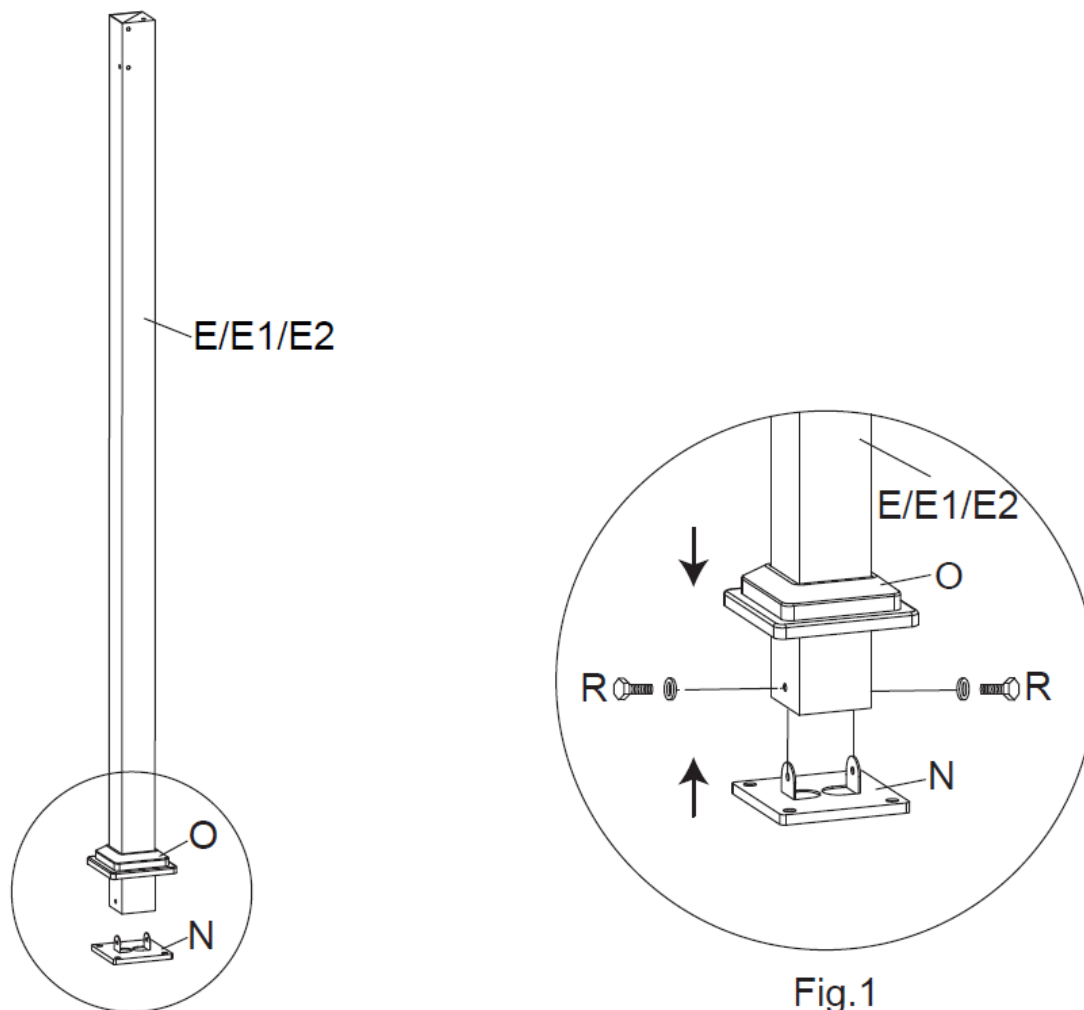

**Step 2:** Insert Cross Beam Center Connector Plate (G) into Cross Beam (D/D1) using Bolt and Washer (R). Repeat for remaining cross beams (D/D1). Insert Cross Beam Center Connector Plate (G) into Cross Beam (D2/D3) using Bolt and Washer (R). See Figure 2. **Tighten Bolts.**

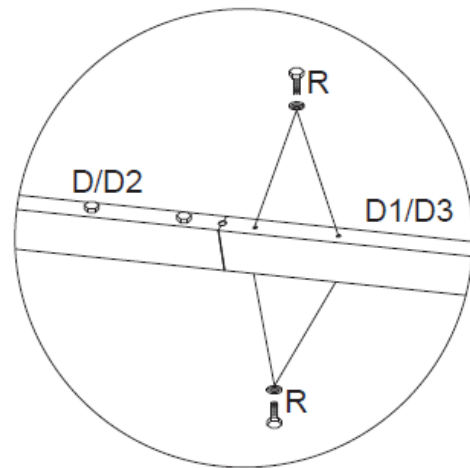
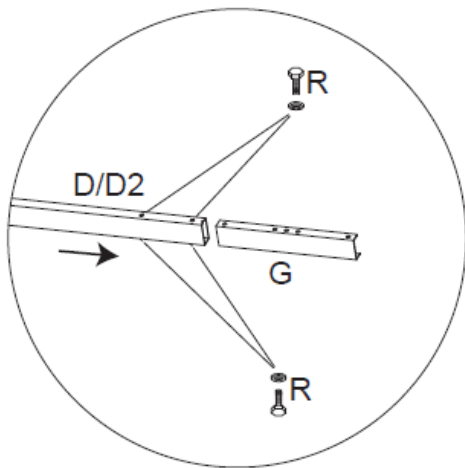
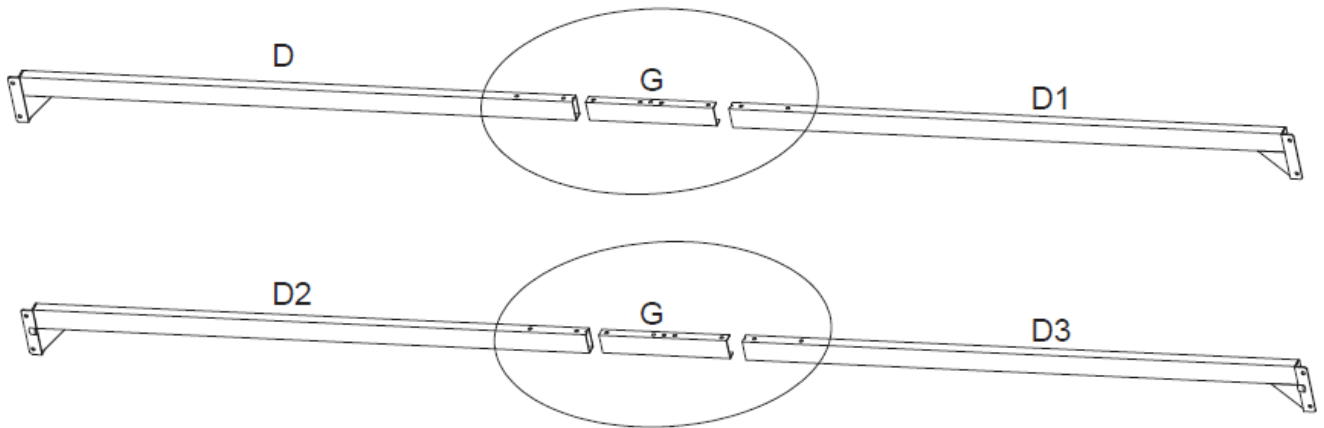

Fig.2

**Step 3A:** Attach Cross Beams (D/D1) to Corner Posts (E/E) using Bolt and Washer (R). Repeat for corner Posts (E/E1) and (E/E2). See Figure 3 and Figure 4.

**DO NOT TIGHTEN BOLTS UNTIL AFTER STEP 4**

**Step 3B:** Attach Cross Beams (D2/D3) to Corner Post (E1/E2) using Bolt and Washer (R). See Figure 3 and Figure 4.

Note: Bar Shelf connector holes must face each other on Corner Posts (E1/E2). See Figure 4A. This is required for installing bar shelves.

**DO NOT TIGHTEN BOLTS UNTIL AFTER STEP 4**

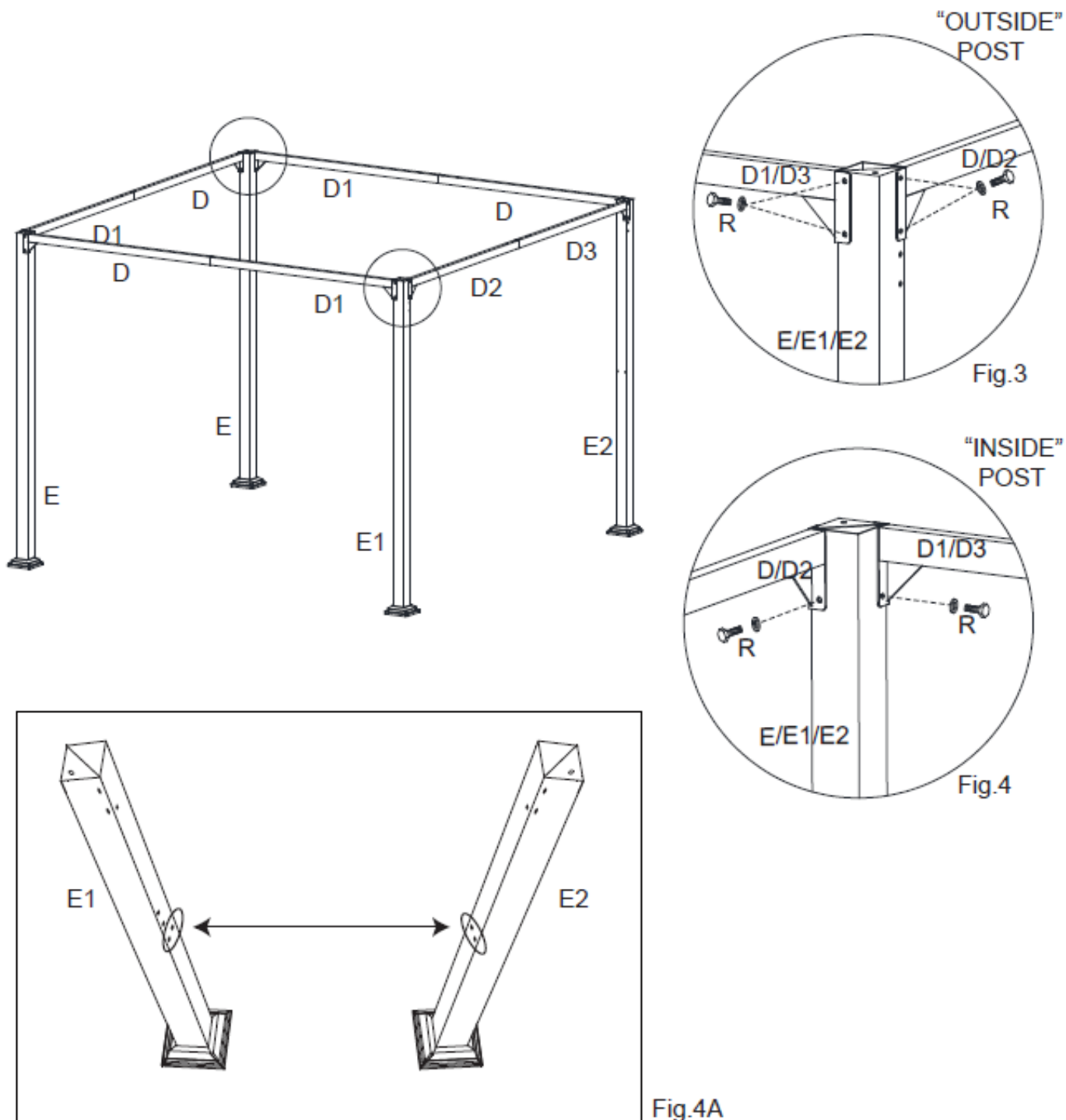



**Step 4A:** Connect the U-Shaped Connector (F) to the top of the Corner Posts using Bolt and Washer (U).  
Repeat for three remaining corner posts. See Figure 5.1.

**Step 4B:** Connect the U-Shaped Connector (F) to the center of the Cross Beams using Bolt and Washer (U).  
Repeat for three remaining Cross Beams. See Figure 5.2.

**Step 4C:** Connect Cross Beam Corner Plates (F1) across the top of the beams using Bolt and Washer (R).  
Repeat for each corner. See Figure 6.

**TIGHTEN ALL BOLTS FROM STEP 3 AND STEP 4**

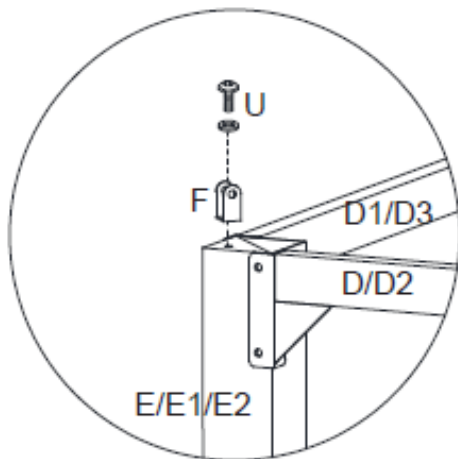
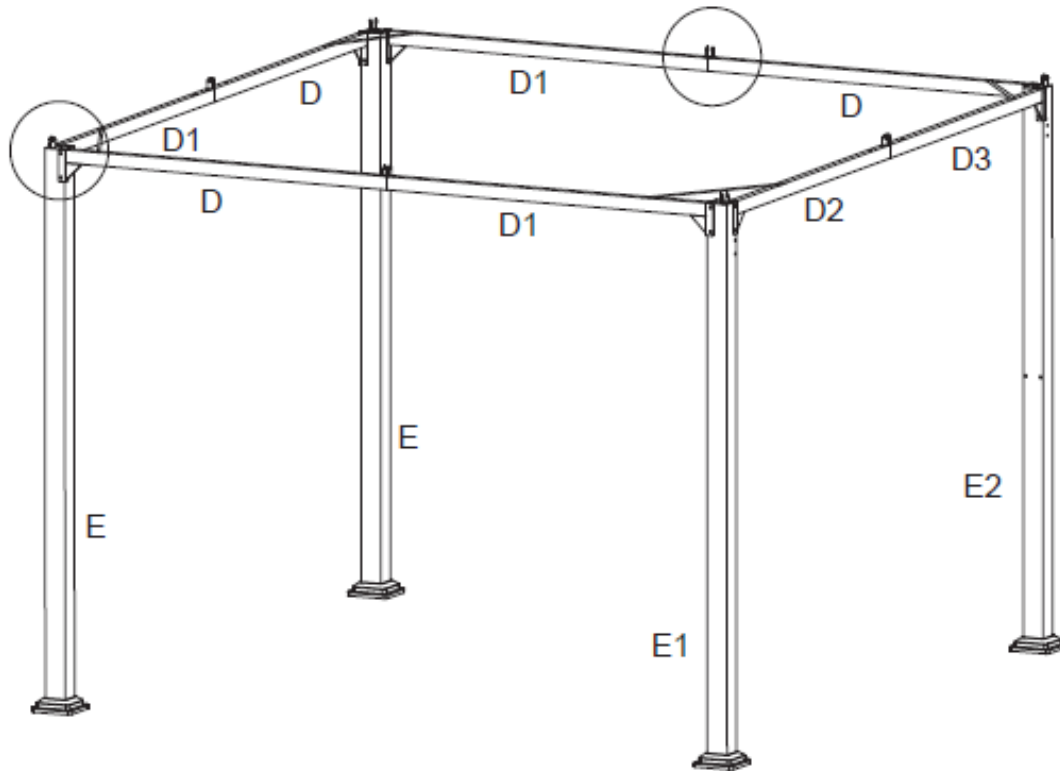

Fig.5.1

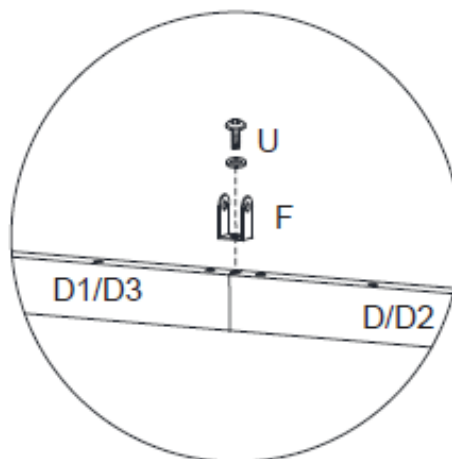

Fig.5.2

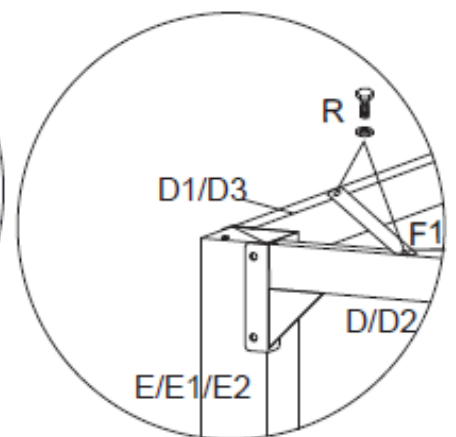

Fig.6

**Step 5A:** Screw the Accessory Hook (Y) into the Main Roof Connector (A). Insert the Main Corner Roof Support (B) into Main Roof Connector (A) until the "push button" lock clicks. Repeat for the three remaining Main Roof Corner Supports (B). See Figure 7.

**Step 5B:** This step requires two people. One person (with the use of a ladder) holds the Main Roof Connector (A) and the corner supports (above the cross beams) while the second person inserts one Main Roof Corner Support Extension (B1) into a Main Roof Corner Support (B) and attaches it to the U-Shaped Connector (F) on top of the Corner Posts using Bolt, Nut, and Washers (S). Repeat for three remaining extensions (B1). See Figure 8. **TIGHTEN BOLTS.**

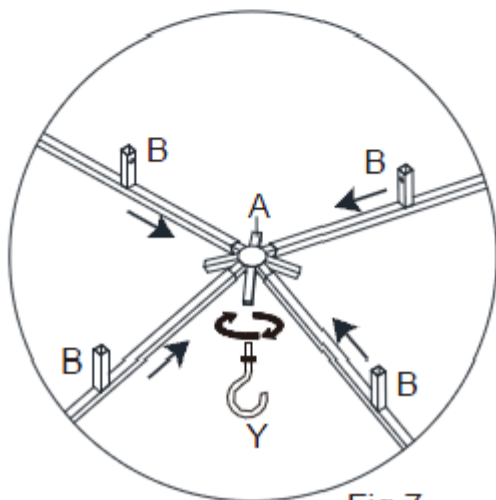
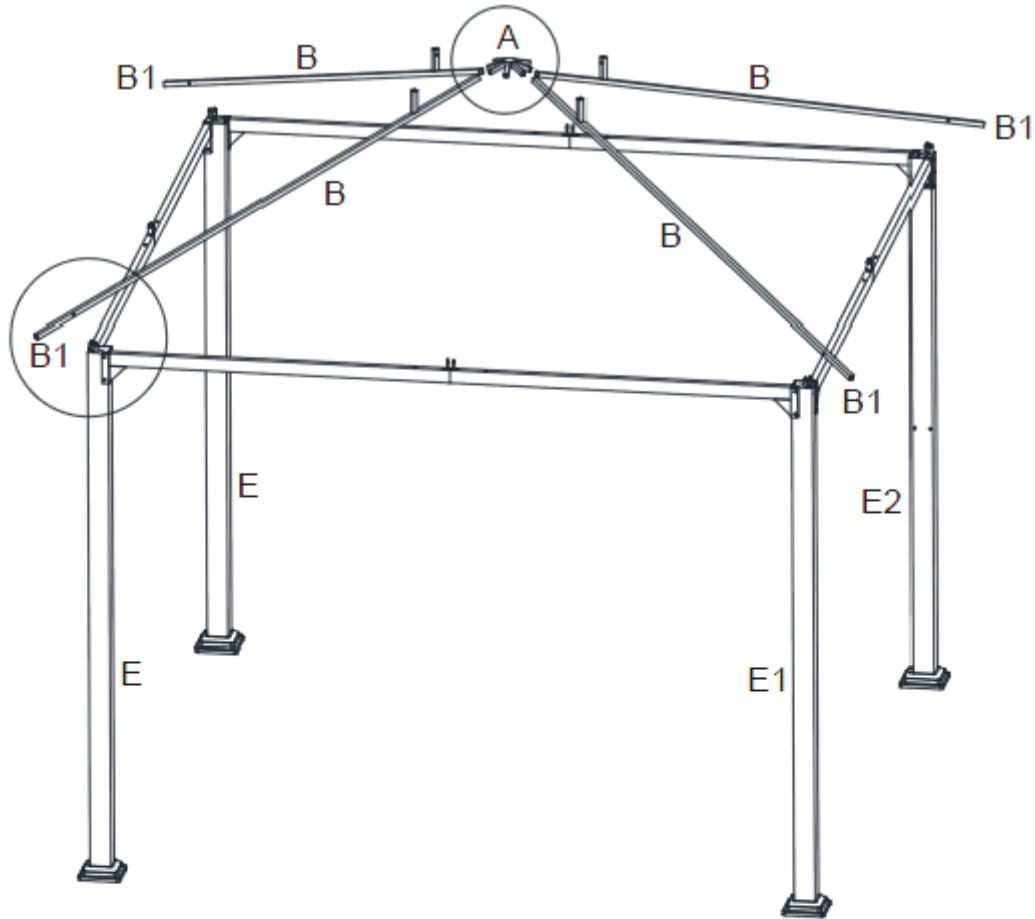

Fig.7

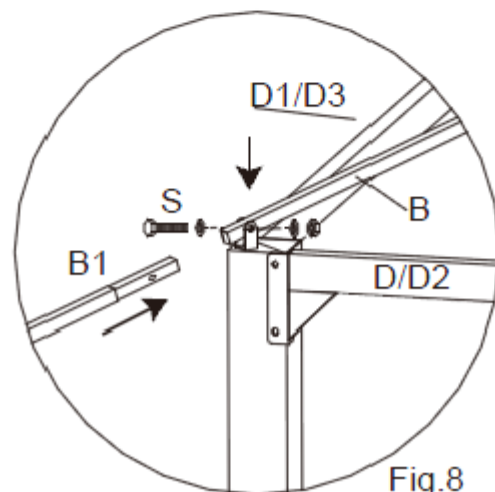

Fig.8

**Step 6:** Insert Main Roof Side Support (C) into the Main Roof Connector (A) until the "push button" lock clicks. Attach the opposite end of the Main Roof Side Support (C) to the U-Shaped Connector (F) in the center of the cross beam using Bolt, Nut, and Washers (S). Repeat for three remaining Side Supports (C). See Figure 9 and Figure 10. **TIGHTEN BOLTS.**

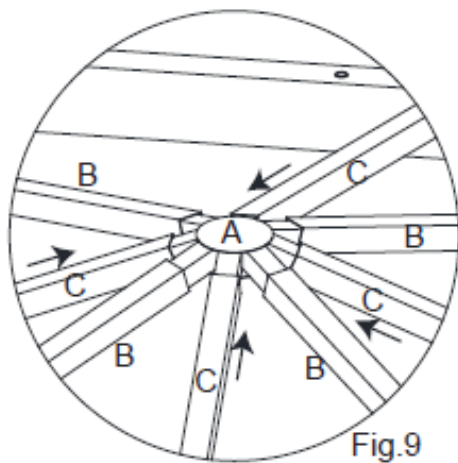
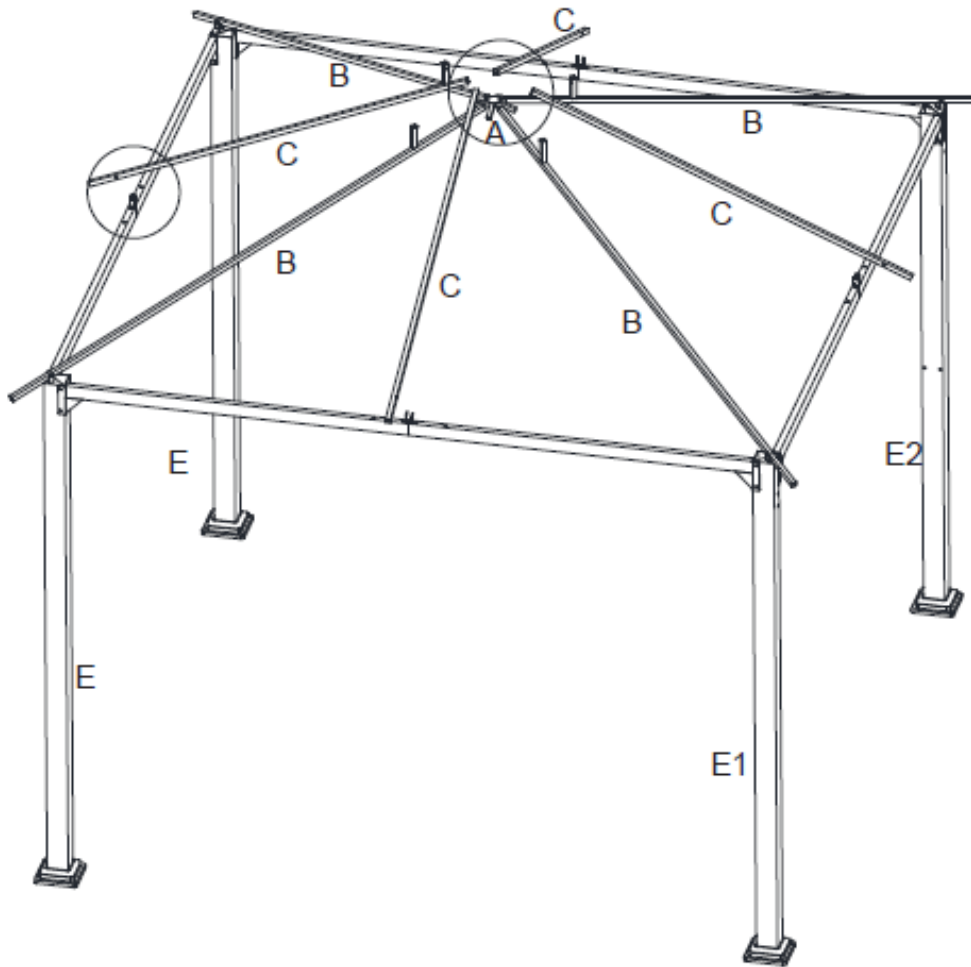

Fig.9

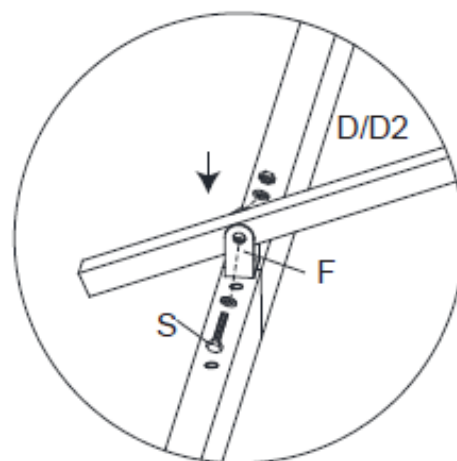
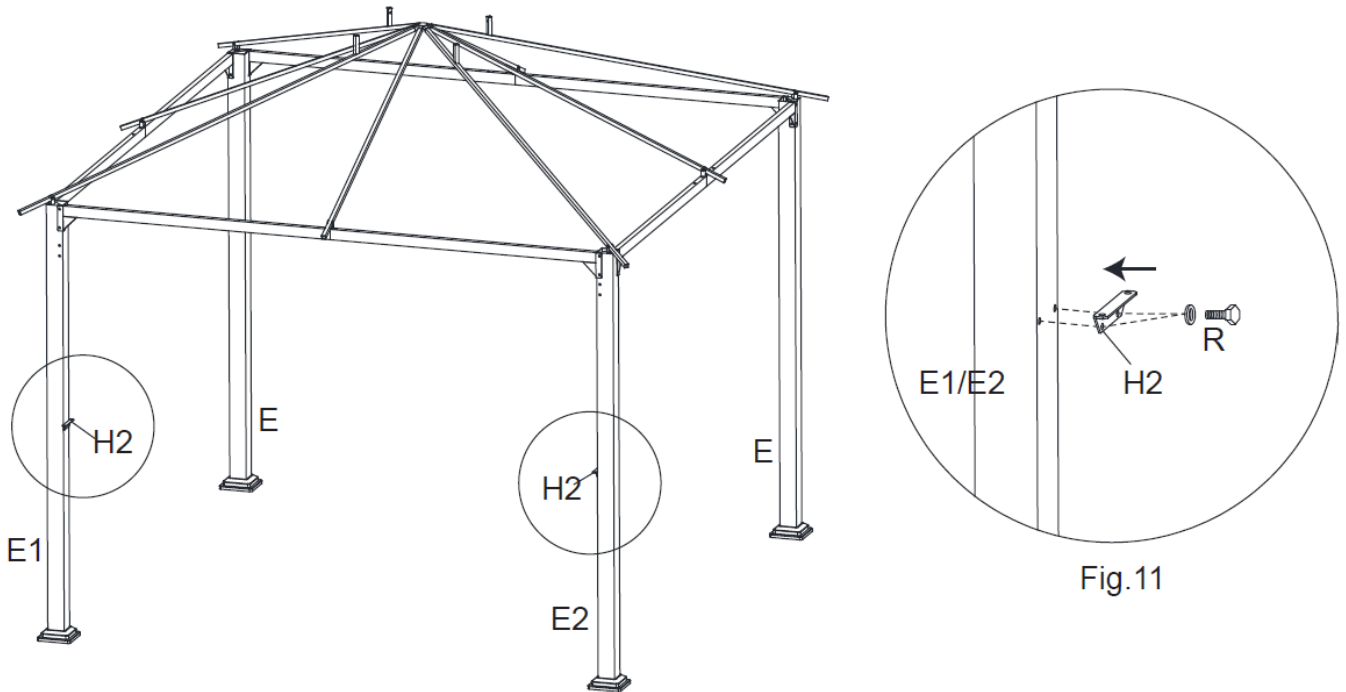
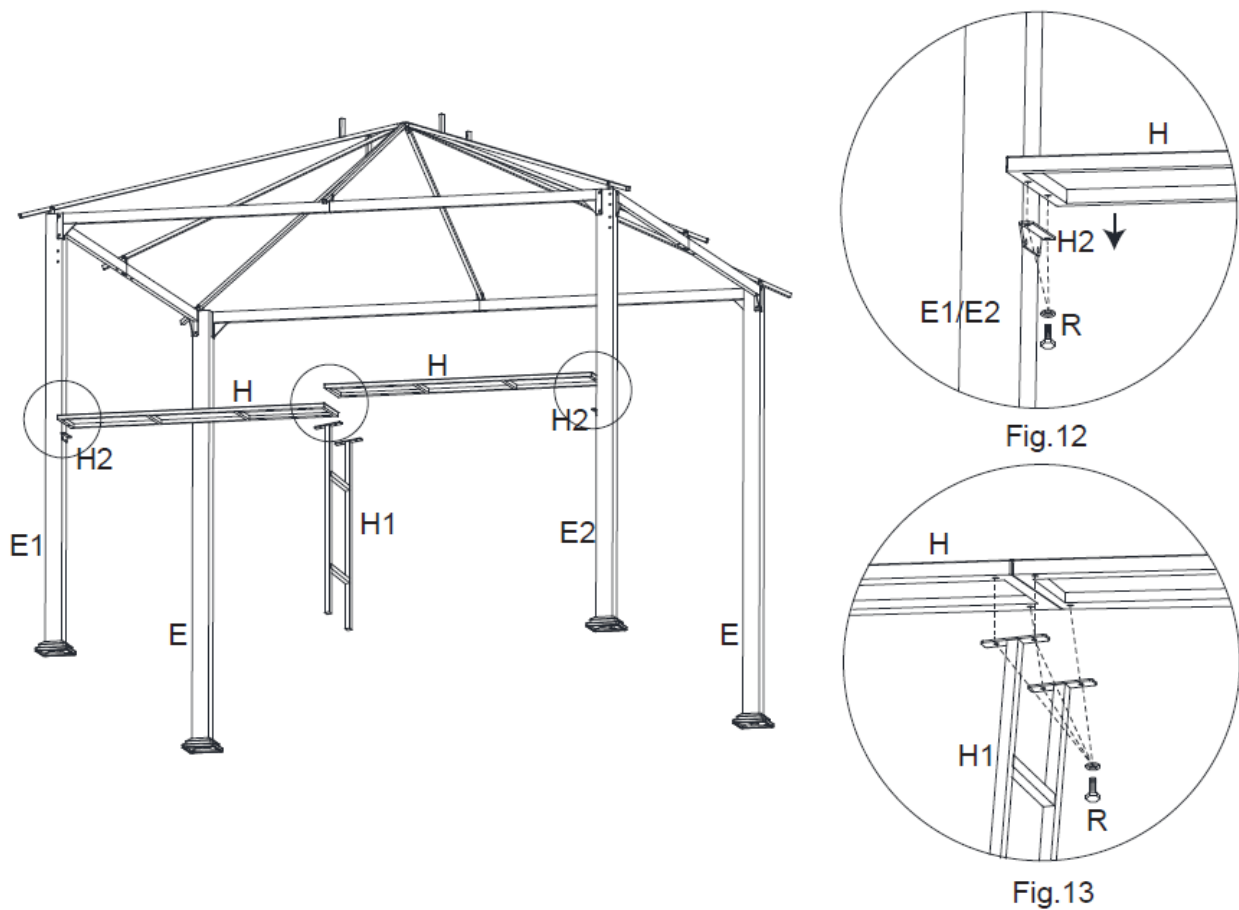

Fig.10

**Step 7:** Connect the Bar Connector (H2) to the Corner Post (E1/E2) and tighten with Bolt and Washer (R). See Figure 11. **TIGHTEN BOLTS.**



**Step 8:** Using two people connect one end of the Bar Shelf (H) to Bar Connector (H2) using Bolt and Washer (R). Attach opposite end to the Bar Support Stand (H1) using Bolt and Washer (R). Repeat for second Bar Shelf (H). See Figure 12 and Figure 13. **TIGHTEN BOLTS.**



**Step 9:** Assemble Upper Roof Frame:

Insert Upper Roof Support (A2) to Upper Roof Connector (A1) until "push button" lock clicks.

Repeat for three remaining supports.

Attach Upper Roof Vent Canopy (P1) to the upper roof frame. See Figure 14.

Screw the Finial (A3) into the upper roof frame. See Figure 15.

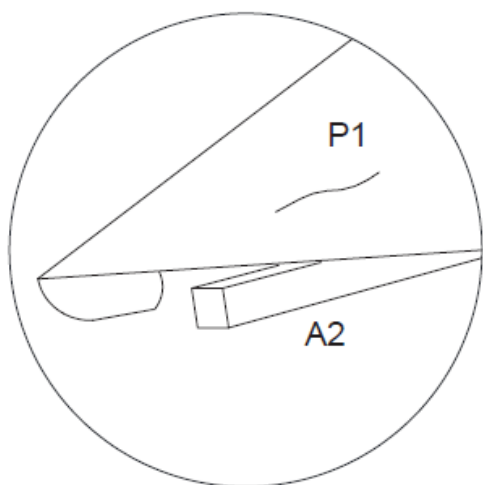
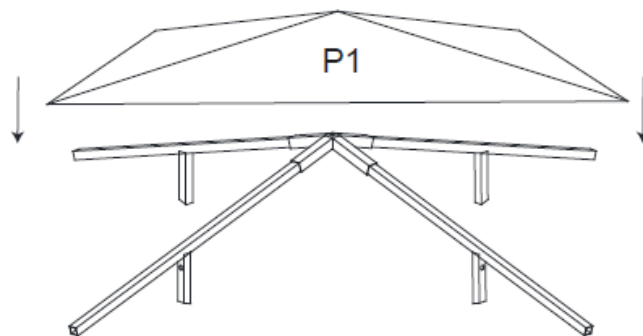
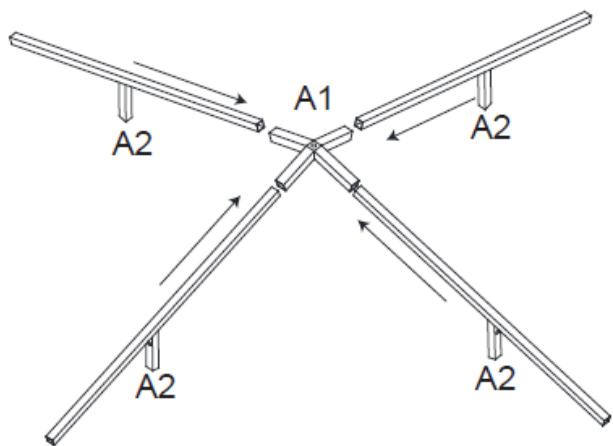

Fig.14

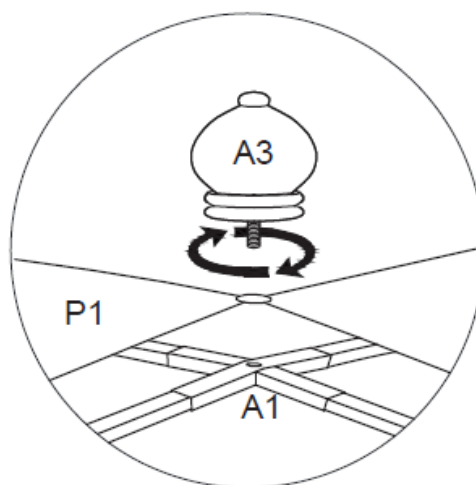
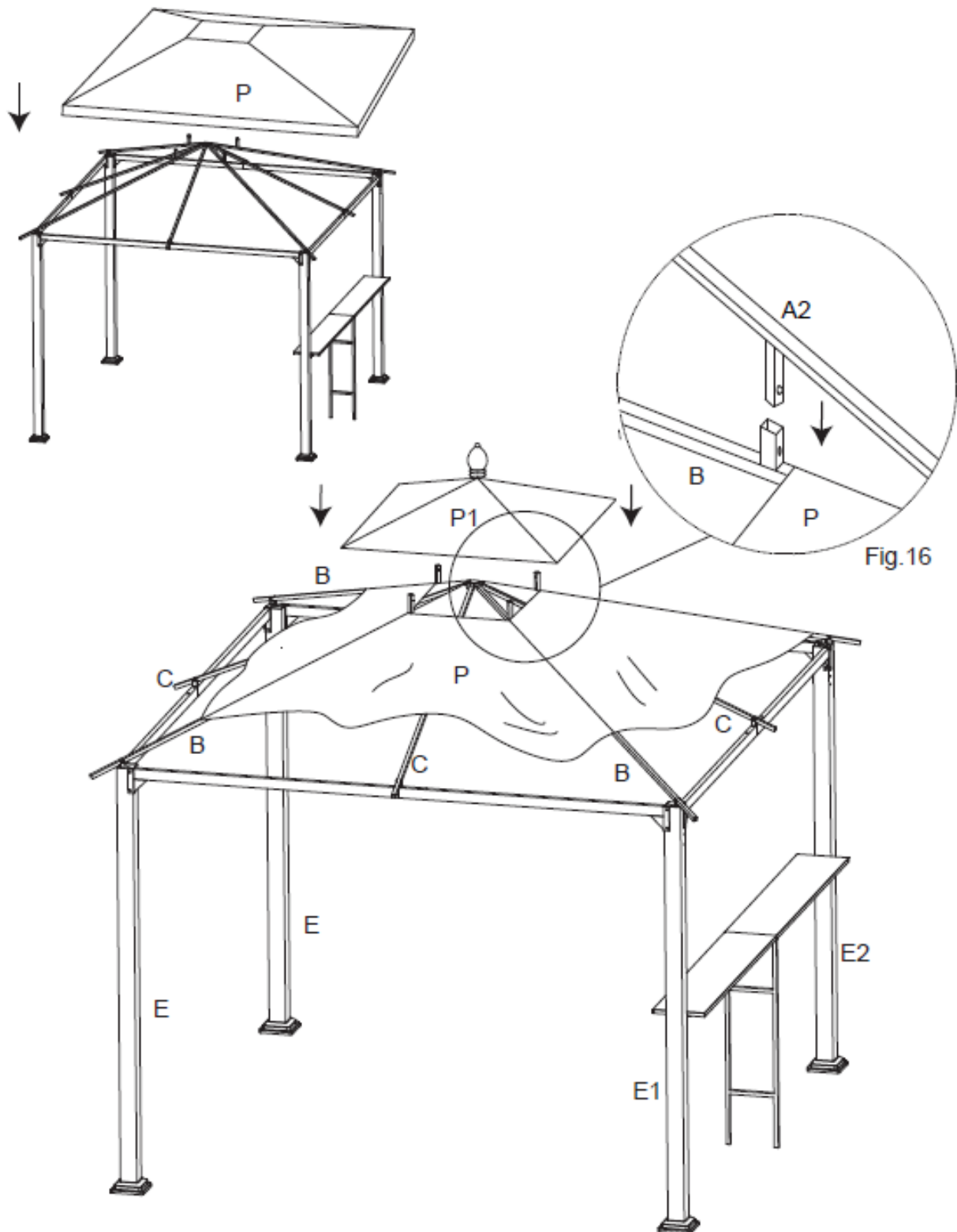

Fig.15

**Step 10A:** Place Main Roof Canopy (P) over main roof frame.

Note: The Main Roof Canopy (P) has two "open" corner seams. The "open" corner seams are placed over Corner Posts (E1/E2). Do not secure the Main Roof Canopy (P) until the upper roof frame is installed.

**Step 10B:** Attach assembled upper roof frame by inserting the Upper Roof Support (A2) into the Main Roof Corner Supports (B) until the "push button" lock clicks. Repeat for each corner. See Figure 16.



**Step 11A:** Secure the Main Roof Canopy (P) to the four Main Roof Corner Support Extensions (B1). See Figure 17.

**Step 11B:** Secure the Main Roof Canopy (P) to the four Main Roof Side Supports (C). See Figure 18.  
Note: Canopy will be tight once secured to the roof frame.

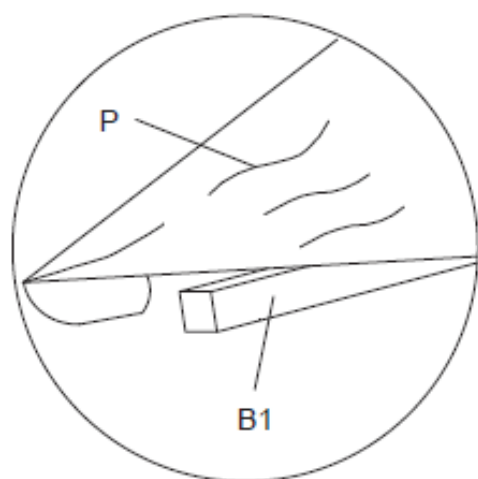
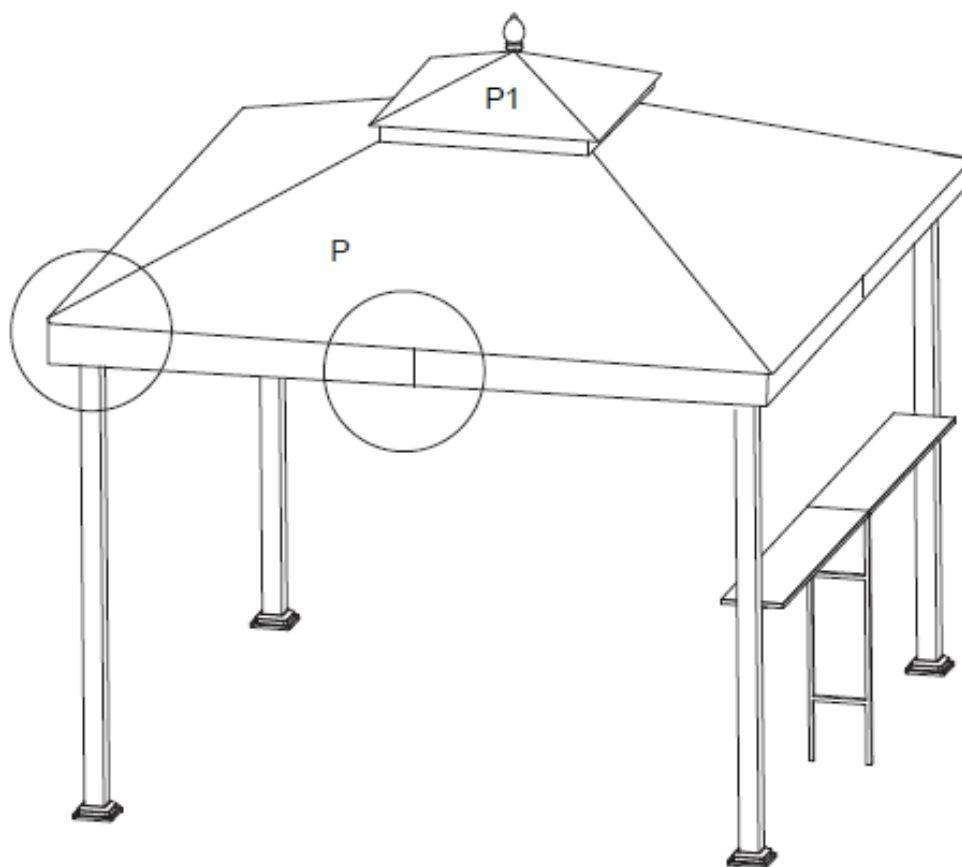

Fig.17

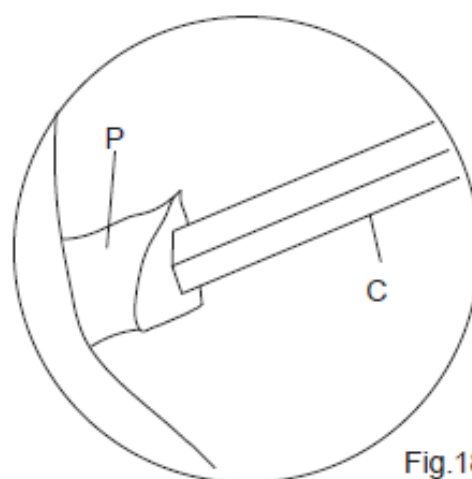

Fig.18

**Step 12:** Awning Assembly

**Note:** Assemble awning frame before attaching awning canopy (Q).

**Step 12A:** Attach Left Awning Frame (I) to Back Awning Frame (J) with Bolts and Washers (R). Repeat for Right Awning Frame (I1) and Back Awning Frame (J1). See Figure 19.

**Step 12B:** Attach Back Awning Frame (J) to the Back Awning Frame (J1) and the Center Awning Frame (K) with Bolts and Washers (R). Repeat for the front awning frame. See Figure 20 and Figure 21.

**Step 12C:** Attach Awning Corner Connector (I2) to Right Side Awning Frame (I1) and Front Awning Frame (J1) using Bolts and Washers (R). See Figure 22.

Repeat for second Awning Corner Connector (I2) to Left Side Awning Frame (I) and Front Awning Frame (J) using Bolts and Washers (R). **TIGHTEN BOLTS.**

**Step 12D:** Place Awning Canopy (Q) over assembled awning frame and secure with velcro.

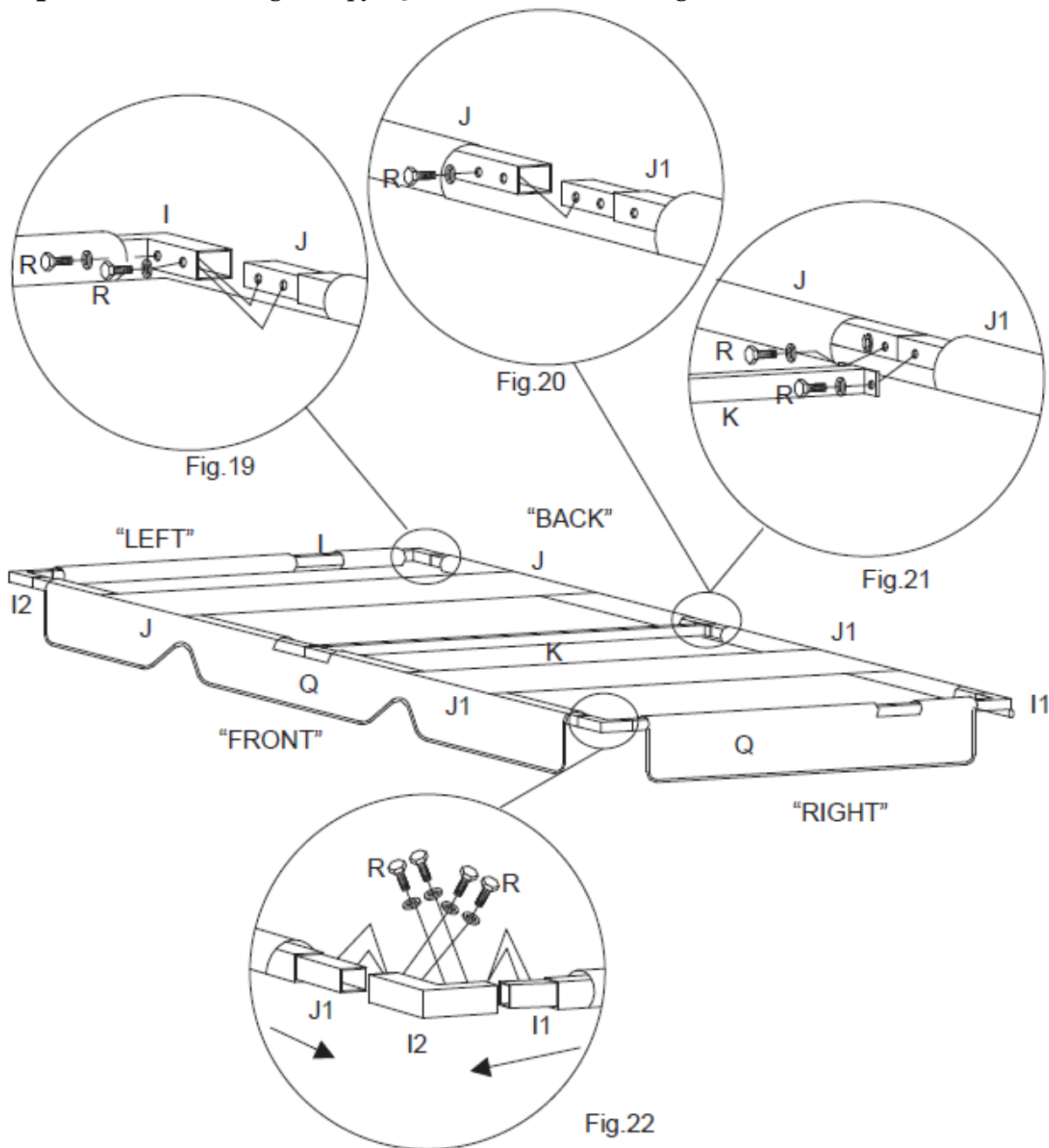



**Step 13:** Using two people attach assembled awning to gazebo.

**Step 13A:** Connect the back of awning to Corner Posts (E1 and E2) using Bolt, Nut and Washer (T). See Figure 23.1.

**Step 13B:** Connect one end of the Awning Hydraulic Rod (L) to Corner Post (E1) and the opposite end to awning frame using Bolts and Washers (R). Repeat for second Hydraulic Rod (L) on Corner Post (E2). See Figure 23.2.

**Step 13C:** Attach the Awning Lock (M) to Corner Posts (E1) using Bolts and Washers (R). See Figure 24.1. **TIGHTEN BOLTS.**

**Step 13D:** When awning is in the closed position use the Awning Lock (M) to secure awning to gazebo frame. See Figure 24.2.

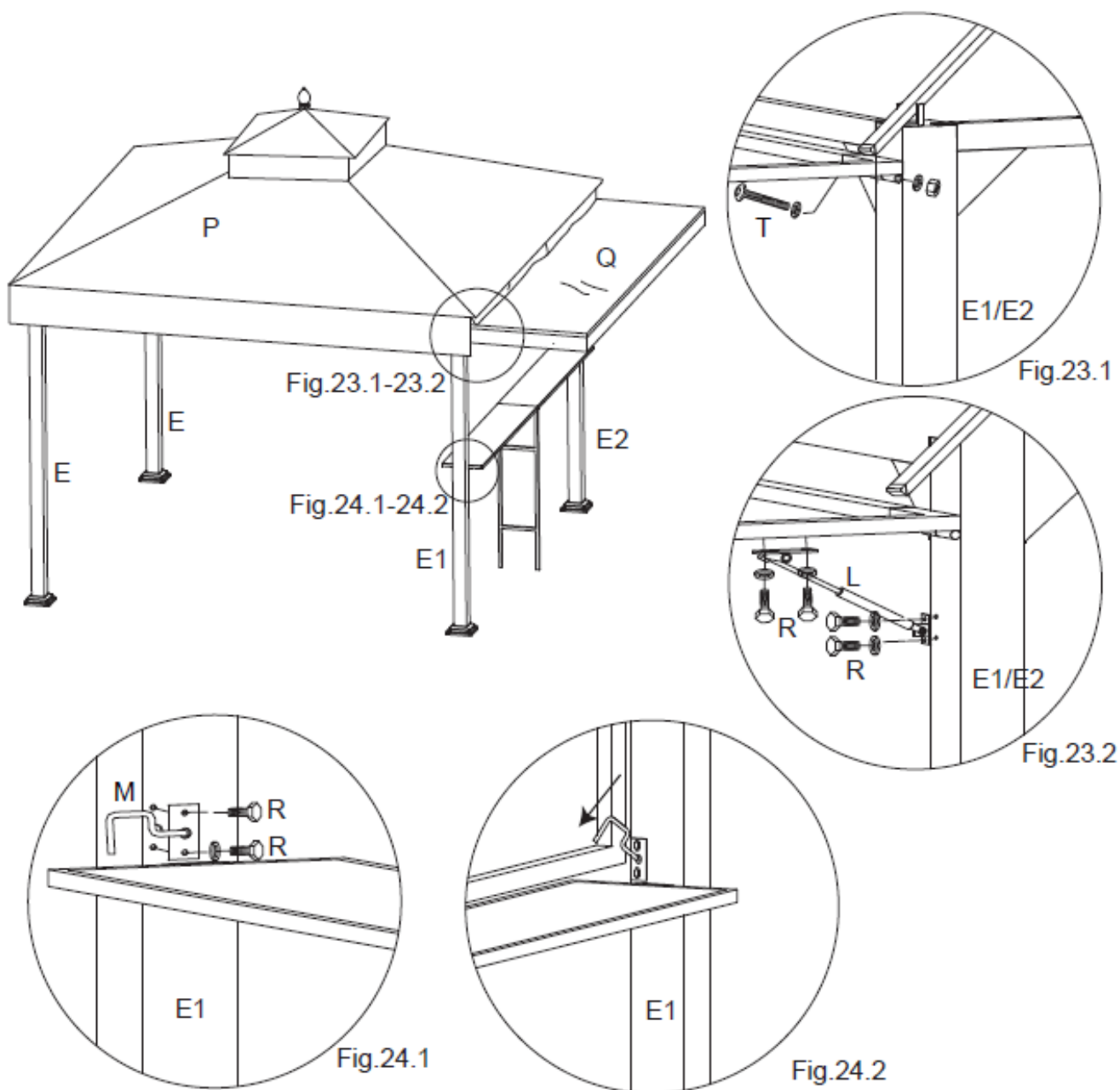

**Step 14:** Insert four Stakes (X) into the ground through the Base Plate (N). Repeat for each corner. See Figure 25.

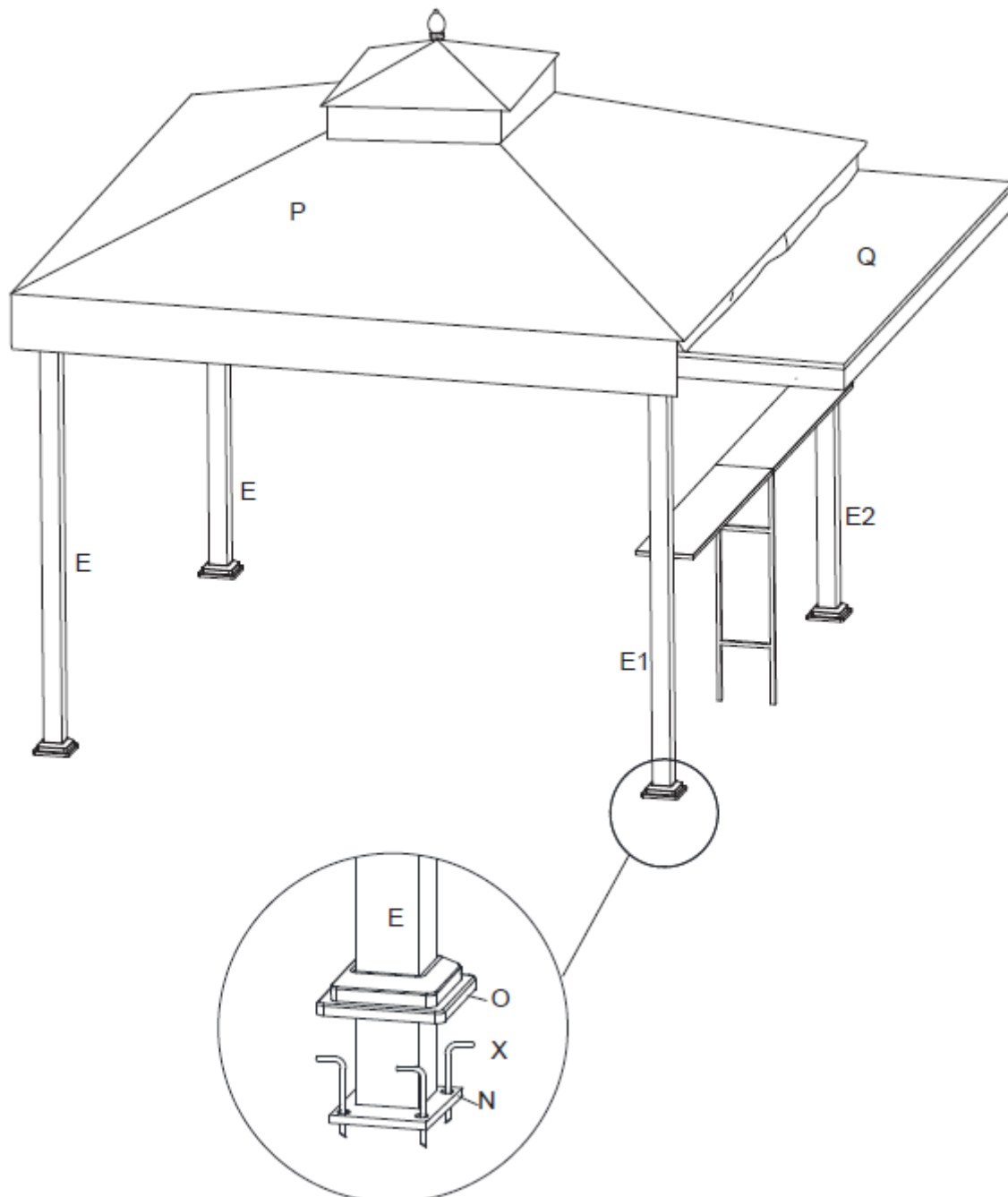

Fig.25

**Note: Please see our video for additional assembly assistance:**  
<https://shadenshelters.com/conley-gazebo-with-awning>

## **Care & Maintenance**

Maintain your outdoor gazebo by removing the canopies and storing out of the elements when not in use, or during hazardous weather conditions (wind, rain, snow, etc.).

**Frame:** Clean frames with a mild soap and warm water. Do not use abrasive materials, cleaners or bleach. Rinse with clean water and dry thoroughly. Always clean, drain and dry thoroughly before storing for the winter.

**Fabric:** Main roof canopy, upper roof vent canopy, and awning canopy may be cleaned by hand with a mild solution of soap and water. Rinse canopies thoroughly and allow to drip dry. Do not machine wash or tumble dry, as canopies may shrink. Do not use bleach or solvents on canopies.

## **Warranty**

You must retain the original receipt to obtain warranty service.

### **What is covered?**

**Frame:** Frame is warranted against rusting for 1-year

**Finish:** Frame finish is warranted against peeling, cracking or blistering for 1-year if the product has not been scratched or abraded.

**Fabric:** Main roof canopy, upper roof vent canopy, and awning canopy are covered by a 1-year warranty against manufacturing defects.

### **What is not covered?**

**EXCLUSIONS:** Gazebo use for commercial, contract, or other non-residential purposes, damage due to acts of nature, vandalism, misuse, or improper assembly are not covered. Discoloration or fading of the finish or fabrics as a result of chemicals or spills, pool water chemicals or salt water is not covered. Mildew of fabric is not covered. Corrosion and rusting of frames and hardware is not covered. If within the stated warranty period this product is found to be defective in material or workmanship, the purchaser must contact the manufacturer's customer service department. The manufacturer, at its option, will repair or replace the defective parts. Proof of purchase (dated register receipt) is required for warranty claims. It remains the customer's responsibility to pay for freight and packaging charges to and from the service center. Warranty is to the original purchaser and is non-transferable. Any replacement or warranted items will be in the original style and color, or similar style and color if the original is unavailable or has been discontinued.

Questions, problems, missing or damaged part? Before returning to the store call or email our Customer Service.

Customer Service Contact Information:

**Hours: Monday - Friday 8:00 a.m. - 5:00 p.m. Central Time (CT)**

**Phone: 1-888-607-4417**

**Email: [service@shadenshelters.com](mailto:service@shadenshelters.com)**