

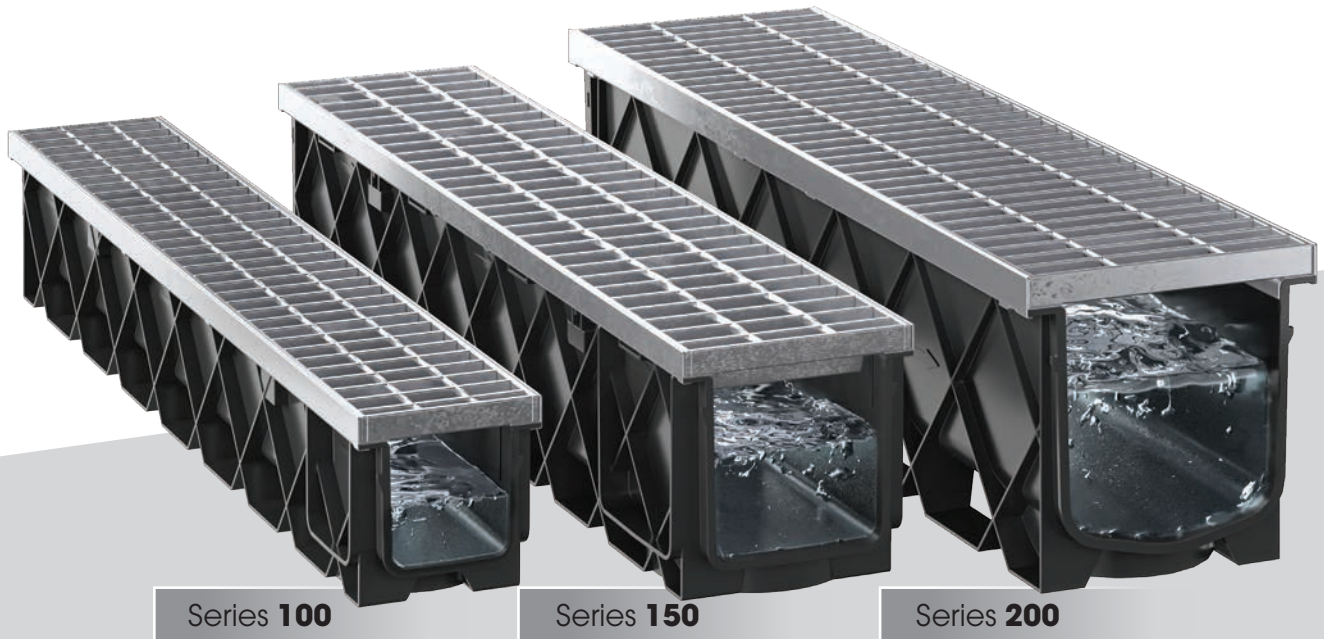

Storm Drain Pro™ Complete Trade Range



Series 100

Series 150

Series 200

Designed for professionals needing a reliable, easy to install surface water solution

RELN Storm Drain Pro™ Series is our newest addition to our surface water drainage range, perfect for large domestic and light commercial applications. With a selection of large profiles, Storm Drain Pro™ effectively collects and distributes substantial volumes of surface water. The Series 100 and Series 150 channels innovative design features an integral side flange to create corners and intersections, removing the need to source additional fittings.

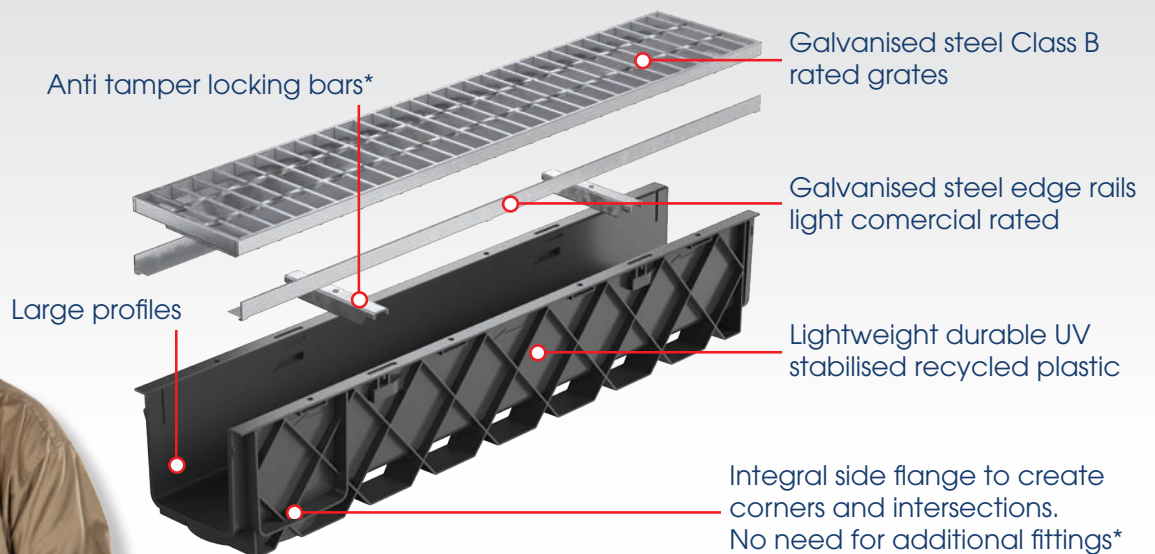

5
YEAR
CHANNEL

1
YEAR
GRATE

PRODUCT
WARRANTY



100%
UV STABILISED
RECYCLED PLASTIC



*Series 100 - 150 only

Series 100



Bottom Outlet Pipe size
DN90mm & DN100mm

Integral Side Flange
Both sides

Product Code
210041 Series 100 c/w Gal Class B Grate
210043 Series 100 c/w H/Guard Class B Grate



Series 150



Bottom Outlet Pipe size
DN90mm, DN100mm & DN150mm

Integral Side Flange
Both sides

Product Code
210010 Series 150 c/w Gal Class B Grate
210012 Series 150 c/w H/Guard Class B Grate



Series 200

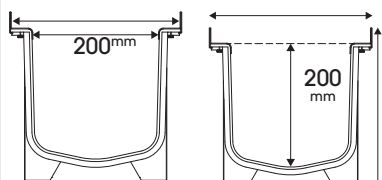

Bottom Outlet Pipe size
DN150mm

Corner & Inline Pit available

Product Code
210071 Series 200 c/w Gal Class B Grate
210073 Series 200 c/w H/Guard Class C Grate

BENEFITS OF STORM DRAIN PRO™

Trade Range – Higher specified range designed to withstand larger load ratings

Durability – Made in Australia from tough, durable, and lightweight UV stabilised recycled plastic

Easy to install – Storm Drain Pro™ is a breeze to install with its easy connecting channels, interchangeable clip-in grates and hold down feet to stop floatation during the pouring of concrete

Galvanised steel edges – Rated to light commercial traffic

Complete drainage solution – With a range of accessories and grate options, Storm Drain Pro™ is perfect for paths, driveways, and domestic areas

Complies to Australian Standard AS3996 Class B and Class C Load Rating – Storm Drain Pro™ is available in two grate options that comply with the AS3996 Class B & Class C Load Ratings