



Heavy Duty Commercial Pits

- Ideal for driveways, carparks and any trafficable areas
- Easy to maintain
- Lock down security grate kits available for Series 450/600
- Australian Made from 100% recycled plastic
- Class A and B grates available & comply to Australian Standards



Large range of grates available, including NEW Anti-Slip Heel Guard Galvanised Steel grate (above), to suit your needs

Series 410



410 Series also available as a RELN Nviro Pit, suitable for domestic stormwater lines where silt and leaves need to be prevented from entering the environment

Series 450



Lock down security kits available for Series 450/600

Risers available for all commercial pits

Series 600

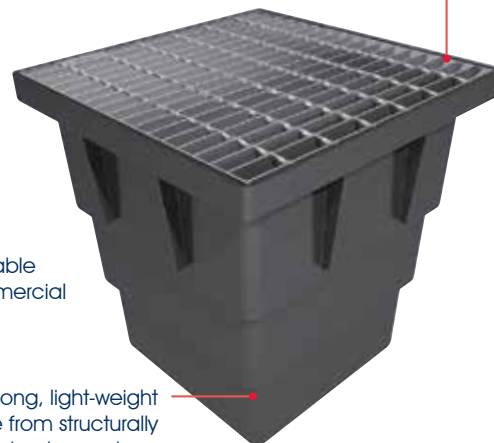

Super-strong, light-weight base made from structurally foamed polypropylene



Heavy Duty Commercial Pits

RELN Heavy Duty Commercial Traditional Pits is a complete range of square and environmental pits with conventional and security grates to suit every heavy commercial application. The range has been designed as a total solution to the environmental and safety hazards commonly associated with commercial drainage.

> Series 410 - Capacity: 75L (460 x 460 x 625mm)

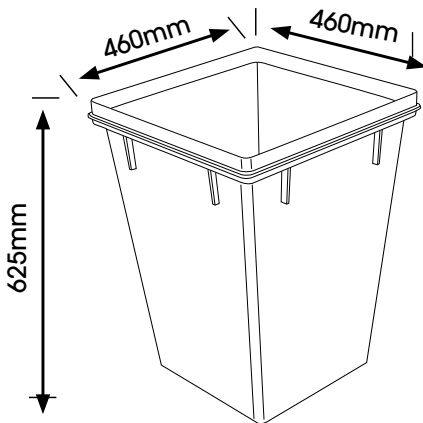

- Ideal for driveways and car parks
- Deep commercial pit
- Preferred where plenty of fall in the stormwater pipes is required

Grate Options: (435 x 435 x 20mm)
Light Duty Galvanised Steel Class A, Anti-Slip Heel Guard Galvanised Steel Class A, Medium Duty Galvanised Steel Class B, Medium Duty Galvanised Steel Checker Plate Cover Class B

Risers: Height 350mm

Accessories: Galvanised Trash Screen with handle.

Display: Brochure Available

> Series 450 - Capacity: 76L (560 x 560 x 510mm)

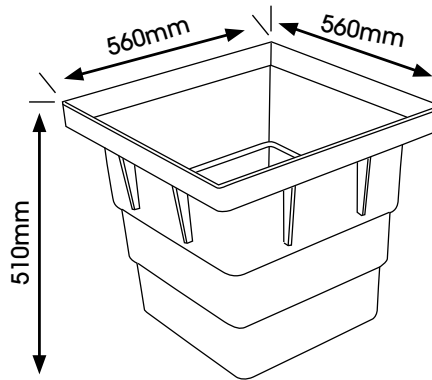

- Ideal for driveways, car parks and any trafficable areas
- Medium heavy duty commercial Pit

Grate Options: (540 x 540 x 50mm)
Light Duty Galvanised Steel Class A, Light Duty Heel Guard Galvanised Steel Class A, Medium Duty Anti-Slip Galvanised Steel Class B, Medium Duty Anti-Slip Heel Guard Galvanised Steel Class B, Medium Duty Galvanised Steel Checker Plate Cover Class B

Risers: Height 300mm

Accessories: Galvanised Trash Screen with handle, Series 450/600 Pit Grate Security Kit

Display: Brochure Available

> Series 600 Deep - Capacity: 175L (710 x 710 x 660mm)

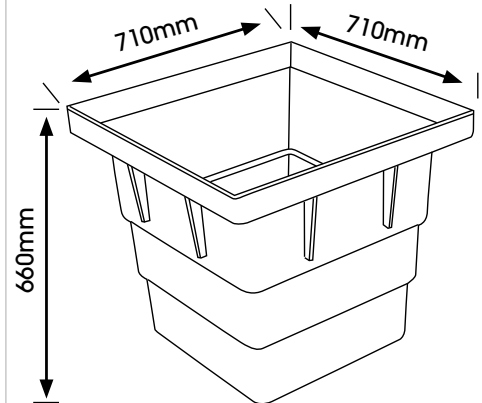

- Ideal for driveways, car parks and trafficable areas
- Large heavy duty commercial pit
- Ideal junction box where large bore pipe is used

Grate Options: (685 x 685 x 50mm)
Light Duty Anti-Slip Galvanised Steel Class A, Light Duty Galvanised Steel Class A, Medium Duty Galvanised Steel Class B, Medium Duty Anti-Slip Heel Guard Galvanised Steel Class B, Medium Duty Galvanised Steel Checker Plate Class B

Risers: Height 300mm

Accessories: Galvanised Trash Screen with handle, Series 450/600 Pit Grate Security Kit

Display: Brochure Available

> Frequently Asked Questions

Q1. What does the Nviro Pit do?

A. The RELN Nviro Pit protects our stormwater systems, wetlands, rivers and watercourses from pollutants, plastic bags, cigarette butts and aluminium cans entering the stream.

Q2. What does the Nviro Pit come with?

A. The RELN Nviro Pit comes with pit base, inner basket and diffuser with either a Light Duty Class A Galvanised grate or a Medium Duty Class B Galvanised grate.

Q3. What size pipes can connect to the pits?

A. Traditional Pits run on a horizontal pipework and can connect to 90mm and 100mm PVC pipe. (Larger PVC stormwater pipes can run through the pits, just cut hole to size).

Q4. What Risers are available?

A. Risers are available for Series 300 (short and deep), 410, 450, 600 Pits. Series 250 Pit uses another Series 250 Pit with bottom cut out. Uni-Pit Vortex require no risers as they connect to vertical pipework. Polymer Concrete pits have their own risers.

Q5. How do I fit the PVC pipe to the Traditional Pits?

A. Use silicon to seal and secure pipework to Traditional Pits. Only Uni-Pit Vortex can be easily secured with silicon glue as well.

Q6. What is the load rating of the grates?

A. See our Class Load Rating table for more information.



Series 410 (Base Only) / Series 410 complete with Grate / Grate Only / Series 410 Pit Accessories

Series 410 Pit complete with Galvanised Steel Class A Grate



Product Code: 001065

Weight: 11kg

Load Rating:

CLASS > A

330kg Light Duty



9 319022 010654

Series 410 Pit complete with Galvanised Steel Class B Grate



Product Code: 001058

Weight: 13.5kg

Load Rating:

CLASS > B

2670kg Medium Duty



9 319022 010586

Series 410 pit Base Only



Product Code: 001072

Weight: 5.5kg

Load Rating:

N/A



9 319022 010722

Series 410 Pit Galvanised Steel Class A Grate Only



Product Code: 001096

Weight: 5.5kg

Load Rating:

CLASS > A

330kg Light Duty



9 319022 010968

Perfect for light commercial applications

Series 410 Pit Galvanised Steel Class B Grate Only



Product Code: 001089

Weight: 8kg

Load Rating:

CLASS > B

2670kg Medium Duty



9 319022 010890

Perfect for commercial applications

Series 410 Pit Checker Plate Galvanised Class B Cover Only



Product Code: 001090

Weight: 10.72kg

Load Rating:

CLASS > B

2670kg Medium Duty



9 319022 010906

Perfect for commercial applications

Series 410 Riser - 350mm



Product Code: 001006

Weight: 2kg



9 319022 010067

Series 410 Pit Galvanised Steel Trash Screen



Product Code: 001097

Weight: 2.87kg



9 319022 010975

**Reln Nviro Pit complete
with Galvanised Steel
Class A Grate**
Product Code: 001000

Weight: 1.2kg

Load Rating:
CLASS >A
 330kg Light Duty

9 319022 010005

**Reln Nviro Pit complete
with Galvanised Steel
Class B Grate**
Product Code: 001017

Weight: 1.7kg

Load Rating:
CLASS >B
 2670kg Medium Duty

9 319022 010173

Series 450 Nviro Pit protects our waterways.

Installation Instructions

Preparation

1. Dig a suitable hole approx 700mm deep and 650mm square inline with stormwater pipeline **(See diagram B)**
 - For best performance the Nviro Pit™ inlet and outlet should be diagonally opposed to the right hand side and we recommend this for all new installations. **(See Diagram B)**.
2. Cut 2 x 90mm holes (diagonally opposite) for inlet and outlet of stormwater pipe. Hole centres should be 430mm from the base. **(See Diagram B)**.
 - Bed the base of the pit approx 70mm of sand. **(See Diagram B)**.
 - Position pit into hole.

Installation

3. Fit stormwater inlet pipe into pit. Seal with silicone. The inside of the inlet pipe must be flush with the wall of the pit (This allows easy Collection Basket removal). If collecting surface water from drainage channel, use an end cap and connect a stormwater pipe into the Nviro Pit.™
4. Fit stormwater outlet pipe allowing a 25–30mm protrusion into pit. This allows for fitting of the Diffuser Elbow and removal of collection basket **(See Diagram C)**.
5. Fit collection basket firmly and flush into the base of the pit. The Collection Basket Handle is to fit into the moulded recess.
6. Fit the Diffuser Elbow to outlet pipe inside the pit facing down –DO NOT GLUE. (The Diffuser Elbow must be removed to allow removal of Collection basket) **(See Diagram C)**.
7. When the Nviro Pit™ is set and pipes connected, backfill the hole with sand.
8. Set a collar of concrete around top of pit, minimum of 150mm deep and 150mm wide surrounding the pit. The Nviro Pit™ grate is Class A and is suitable for domestic vehicular traffic. **(See Diagram A)**.

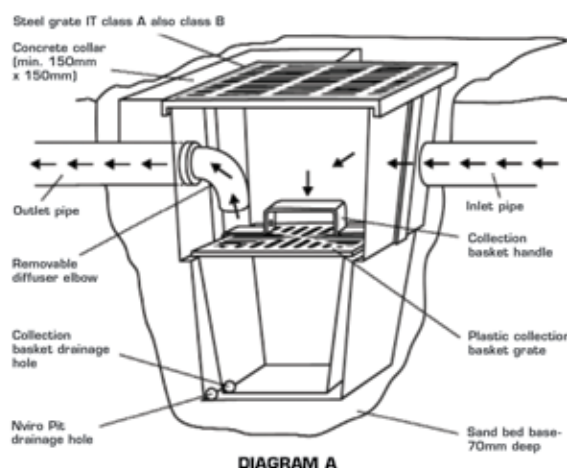
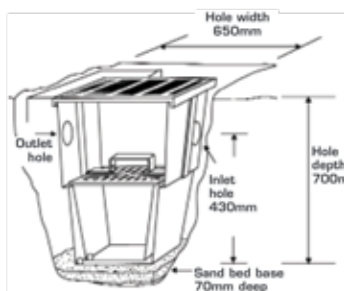
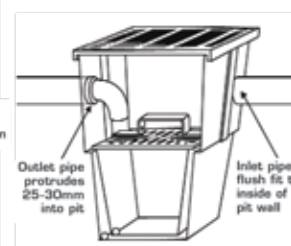
DIAGRAM A

**DIAGRAM B
PREPARATION**

**DIAGRAM C
INSTALLATION**

Product Specifications.

O/A Size: 460 x 460 x 625mm

Capacity: 75Litres

All up weight with Class A grate 16kg

All up weight with Class B grate 20kg

Galvanised Steel Class A Grate (1 Ton)

Galvanised Steel Class B Grate (8 Ton)

(All dimensions approximate)



Series 450 pit Grate Only / Series 450 pit Accessories

Series 450 Pit complete with Galvanised Steel Class A Grate



Product Code: 001110

Weight: 16.65kg

Load Rating:

CLASS **A**

330kg Light Duty



Series 450 Pit complete with Galvanised Steel Class B Grate



Product Code: 001111

Weight: 20.20kg

Load Rating:

CLASS **B**

2670kg Medium Duty



Series 450 Pit complete with Galvanised Steel Flat Bar Heel Guard Class A Grate



Product Code: 001123

Weight: N/A

Load Rating:

CLASS **A**

330kg Light Duty



Series 450 Pit Checker Plate Gal Class B Cover Only



Product Code: 001091

Weight: 16kg

Load Rating:

CLASS **B**

2670kg Medium Duty



Perfect for commercial applications

Series 450 Pit Base Only



Product Code: 001109

Weight: 6.5kg

Load Rating:

Residential

Light Duty



Series 450 Pit Galvanised Steel Class A Grate Only



Product Code: 001112

Weight: 10.2kg

Load Rating:

CLASS **A**

330kg Light Duty



Perfect for light commercial applications

Series 450 Pit Galvanised Steel Class B Grate Only



Product Code: 001113

Weight: 13.8kg

Load Rating:

CLASS **B**

2670kg Medium Duty



Perfect for commercial applications

Series 450 Riser - 300mm



Product Code: 001093

Weight: 5kg





Series 600 pit (Base Only) / Series 600 pit complete with Grate / Series 600 pit Grate only

Series 450 Pit Anti-Slip Heel Guard Galvanised Steel Class A Grate Only



Product Code: 001144

Weight: 13kg

Load Rating:

CLASS >A

330kg Light Duty



Perfect for light commercial and pedestrian applications

Series 450 Pit Anti-Slip Heel Guard Galv Steel Class B Grate Only



Product Code: 001145

Weight: 15kg

Load Rating:

CLASS >B

2670kg Medium Duty



Perfect for commercial applications

Series 450 Pit Galvanised Steel Trash Screen



Product Code: 001098

Weight: 2.8kg



Perfect for commercial applications

Series 450/Series 600 Pit Grate Security Kit



Product Code: 002270

Weight: 0.12kg



	Class Loading	Typical Use	Nominal Wheel Loading kg	Serviceability Design Load kN	Ultimate Limit State Design Load kN
	RESIDENTIAL	Non-rated usage. Designed for residential applications such as pathways and driveways.	N/A	N/A	N/A
	CLASS >A	Areas (including paths) accessible only to pedestrians and pedal cyclists and closed to other traffic.	330	6.7	10
	CLASS >B	Areas (including paths and light tractor paths) accessible to vehicles (excl. commercial vehicles) or livestock.	2670	53	80
	CLASS >C	Malls and areas open to slow moving commercial vehicles.	5000	100	150
	CLASS >D	Carriageways of roads and areas open to commercial vehicles.	8000	140	210
	CLASS >E	General docks and aircraft pavements.	13 700	267	400
	CLASS >F	Docks and aircraft pavements subject to high wheel loads.	20 000	400	600
	CLASS >G	Docks and aircraft pavements subject to very high wheel loads.	30 000	600	900

Series 600 pit complete with Galvanised Steel Class A Grate



Product Code: 001115

Weight: 24.8kg

Load Rating:

CLASS > A

330kg Light Duty



9 319022 011156

Series 600 pit complete with Galvanised Steel Class B Grate



Product Code: 001116

Weight: 33.2kg

Load Rating:

CLASS > B

2670kg Medium Duty



9 319022 011163

Series 600 pit complete with Galvanised Steel Flat Bar Heel Guard Class A Grate



Product Code: 001131

Weight: 32kg

Load Rating:

CLASS > A

330kg Light Duty



9 319022 011316

Series 600 pit complete with Galvanised Steel Flat Bar Heel Guard Class B Grate



Product Code: 001139

Weight: 34kg

Load Rating:

CLASS > B

2670kg Medium Duty



9 319022 011392

Series 600 Pit Base Only



Product Code: 001117

Weight: 12.5kg

Load Rating:

N/A



9 319022 011170

Series 600 pit Galvanised Steel Class A Grate Only



Product Code: 001120

Weight: 12.3kg

Load Rating:

CLASS > A

330kg Light Duty



9 319022 011200

Perfect for light commercial applications

Series 600 pit Galvanised Steel Class B Grate Only



Product Code: 001118

Weight: 20.7kg

Load Rating:

CLASS > B

2670kg Medium Duty



9 319022 011187

Perfect for commercial applications

Series 600 pit Checker Plate Gal Class A Cover Only



Product Code: 001092

Weight: 24.78kg

Load Rating:

CLASS > A

330kg Light Duty



9 319022 010920

Perfect for light commercial applications



Series 600 pit Grate Only / Series 600 pit Accessories

Series 600 pit Anti-Slip Heel Guard Galvanised Steel Class A Grate Only



Product Code: 001146

Weight: 18.46kg

Load Rating:

CLASS **A**

330kg Light Duty



Perfect for light commercial and pedestrian applications

Series 600 pit Anti-Slip Heel Guard Gal Class B Grate Only



Product Code: 001147

Weight: 24kg

Load Rating:

CLASS **B**

2670kg Medium Duty



Perfect for commercial and pedestrian applications

Series 600 Riser - 300mm



Product Code: 001122

Weight: 8kg



Series 600 Pit Galvanised Steel Trash Screen



Product Code: 001099

Weight: 4.29kg



Perfect for commercial applications

Series 450/Series 600 Pit Grate Security Kit



Product Code: 002270

Weight: 0.12kg

