



TM



TECHNICAL CATALOGUE

TABLE OF CONTENTS

SECTION 1 - INTRODUCTION

1.1 - Company Overview	3
1.2 - Product Introduction	3
1.3 - Key Features & Benefits	4

SECTIONS 2 – DESIGN POINTS

2.1 - Tube	5
2.2 - Fittings	5
2.3 - O-Rings	5
2.4 - Gaskets	7
2.5 - Applications	7
2.6 - Thermal Expansion	8
2.7 - Corrosion Resistance	9
2.8 - Insulation - Acoustic and Thermal	10
2.9 - Connecting to Different Metals	10
2.10 – Pressure Loss & Flow Rates	11
2.11 - Recommended Water Velocities	12
2.12 - Design Pressures	12
2.13 - Vacuum Applications	12

SECTION 3 – TOOLING

3.1 - Recommended Press Tooling	13
3.2 - Tool Selection	13
3.3 - Operating Instructions	14
3.4 - Tooling Safety and Maintenance	14

SECTION 4 - INSTALLATION OVERVIEW

4.1 - Handling and storage	15
4.2 - Tube Cutting and De-Burring	15
4.3 - Tube Bending	15
4.4 - Insertion Depths	15
4.5 - Distances Between Fittings	16
4.6 - Press Tool Space Requirements	16
4.7 - Installation	17
4.8 - Tube Fixing & Support	19

SECTION 5 – COMMISSIONING, MAINTENANCE AND WARRANTIES

5.1 - Testing	20
5.2 – Disinfection	20
5.3 – De-Scaling	20
5.4 - Commissioning	20
5.5 - Forza Stainless Steel Press Tube & Fittings Warranties	21

SECTION 6 – PRODUCT RANGE PRODUCT CODE/SIZES

6.1 - Fittings: Image/Line Drawing/Dimensions/Product Code/Sizes	25
6.2 - O-Ring Seals: Image/Line Drawing/Dimensions/Product Code/Sizes	46
6.3 - Barrel Union: Image/Line Drawing/Dimensions/Product Code/Sizes	47

SECTION 7 – FREQUENTLY ASKED QUESTIONS

	51
--	----

SECTION 8 – NOTES

	52
--	----

SECTION 1 – INTRODUCTION



1.1 COMPANY OVERVIEW

Forza Global is an Australian owned and operated business that provides exceptional service and quality products to their customers throughout Australia and New Zealand.

Our highly trained staff have the expertise and experience to manage projects of any size across a range of sectors such as commercial and residential construction, oil and gas, industrial, mechanical services, mining, health, education, marine, defense and government sectors.



Through expert category management, we assist our customers to reduce supply chain risk and deliver large, long term projects in sectors with rigorous compliance requirements.

Our extensive range of products allows us to provide solutions to our customers varying needs through the availability of specialty goods that cover a wide range

of traditional and niche markets, giving us the ability to provide a unique value proposition to our customers.

We pride ourselves on unrivalled service and have an on-going commitment to product development for our customers in the Australian and New Zealand markets and have worked diligently with our customers to have our products specified with a number of the largest construction and plumbing companies in Australasia.

1.2 PRODUCT INTRODUCTION

Forza Global in partnership with one of the world's leading stainless steel manufacturers has developed a stainless press system that is fit for purpose for the Australian and New Zealand markets.

Forza Stainless Press is available in sizes DN15 through to DN168 with applications that are extensive due to a range of O-rings capable of use within; heavy industry, chemical, high temperature, water or gas in either 304L and 316L grade depending on system parameters.

1.3 KEY FEATURES & BENEFITS



QUICK & EASY TO INSTALL

- Fast & Clean to install
- Lower installation hours on site
- Reduced installation costs



FLAME-FREE, HEAT-FREE, SAFE CONNECTIONS

- No welding required
- No Hot Works Permits required
- Ideal for use in Retrofit Projects



NO CONSUMABLES

- No welding gas
- No oxy acetylene
- No Silver solder
- No Welding wires
- No cleaning products



ENVIRONMENTALLY FRIENDLY WHEN INSTALLING

- No smoke
- No dangerous gases
- No toxic substances



PERFORMANCE CONSISTENCY

- Uniform connection throughout installation
- Removes issues of welding and joint imperfections
- Simple, quick and reliable installation process
- Secure, permanent joint with encapsulated O-ring



APPROVED

- Australian Watermark Approval: AS 3688:2016 : AS 4020
- Australian Watermark Approval: ATS 5200.053:2008



EASY TO USE TOOLING

- Portable, user friendly tooling
- Compact battery operation



OH&S FRIENDLY

- No ignition – spark
- No open flame
- No risk to others



EXTENSIVE RANGE

- Tube sizes from 15mm to 168mm
- Fitting sizes from 15mm to 168mm



MAINTENANCE FREE

- Long service life



PERFORMANCE

- Up to 40 bar working pressure rating
- Temperature rated to 200 degrees C
- Leak Detection O-rings up to 54mm

SECTION 2 – DESIGN POINTS

2.1 TUBE

Forza Stainless Steel tube has a Watermark license/certificate and is compliant to ATS5200.053:2008 – plumbing and drainage products - Stainless Steel pipes and tubes for pressure application and AS/NZS 4020:2005 - Testing of products for use in contact with drinking water.

Forza Stainless Steel tube combines low carbon, at less than 0.03%, with a minimum molybdenum content of 2%-3% for improved corrosion resistance. Low carbon, austenitic stainless steel is roll formed and then longitudinally plasma-inert gas-welded to precisely form the tubes. Forza Stainless tubes are bright annealed and solution heat-treated, resulting in an attractive, hygienic and durable product.

Tube Specification Table

FORZA STAINLESS TUBE CHART 316L

CODE	SIZE	DRY WEIGHT KG/M	WET WEIGHT, KG/M	VOLUME l/m	LENGTH	MASS PER 6M	WALL THICKNESS
FST15316L	15mm	0.351	0.484	0.133	6M	2.11 KG	1.0mm
FST22316L	22mm	0.625	0.928	0.302	6M	3.75 KG	1.2mm
FST28316L	28mm	0.805	1.321	0.515	6M	4.83 KG	1.2mm
FST35316L	35mm	1.258	2.064	0.804	6M	7.55 KG	1.5mm
FST42316L	42mm	1.521	2.718	1.195	6M	9.13 KG	1.5mm
FST54316L	54mm	1.972	4.017	2.043	6M	11.83 KG	1.5mm
FST76316L	76.1mm	3.711	7.798	4.083	6M	22.27 KG	2.0mm
FST108316L	108mm	5.308	13.810	8.495	6M	31.85 KG	2.0mm
FST168316L	168mm	8.400	29.600		6M	50.30 KG	2.0mm

FORZA STAINLESS TUBE CHART 304L

CODE	SIZE	DRY WEIGHT KG/M	WET WEIGHT, KG/M	VOLUME l/m	LENGTH	MASS PER 6M	WALL THICKNESS
FST15304L	15mm	0.351	0.484	0.133	6M	2.11 KG	1.0mm
FST22304L	22mm	0.625	0.928	0.302	6M	3.75 KG	1.2mm
FST28304L	28mm	0.805	1.321	0.515	6M	4.83 KG	1.2mm
FST35304L	35mm	1.258	2.064	0.804	6M	7.55 KG	1.5mm
FST42304L	42mm	1.521	2.718	1.195	6M	9.13 KG	1.5mm
FST54304L	54mm	1.972	4.017	2.043	6M	11.83 KG	1.5mm
FST76304L	76.1mm	3.711	7.798	4.083	6M	22.27 KG	2.0mm
FST108304L	108mm	5.308	13.810	8.495	6M	31.85 KG	2.0mm

2.2 FITTINGS

Forza Stainless Press has a Watermark license / certificate and is compliant to AS3688:2016 Water Supply and gas systems-Metallic fittings and end connectors and AS4020.

All Forza fittings are optimally designed to ensure the most effective and consistent joint formation, achieving or exceeding the hydraulic and structural requirements of standards. Forza Stainless fittings up to and including 54mm have a leading lip, whereas, the 76.1 mm, 108mm and 168 mm press fittings do not.

2.3 O-RINGS

Forza Stainless Press fittings are available in three separate O-ring types each designed for varying applications. EPDM (Ethylene Propylene Diene Monomer) black O-rings, FKM-R (Fluorocarbon) red O-rings and HNBR (Hydrogenated Nitrile Butadiene Rubber) yellow O-rings.

EPDM (Ethylene Propylene Diene Monomer) possesses excellent resistance to ozone, sunlight and weathering, has very good flexibility at low temperature and good chemical resistance, such as to many dilute acids and alkalis and polar solvents. This O-ring is suitable for hot

and cold potable water applications and some industrial applications. It is not suitable for aromatic hydrocarbons, di-ester based lubricants, halogenated solvents or petroleum based oils and greases.

It is not suitable for any applications with temperatures exceeding 120°C.

FKM-R (Fluorocarbon) O-Ring has excellent resistance to high temperatures up to 200°C (depending on the medium), ozone, weather, oxygen, mineral oil, fuels, hydraulic fluids, aromatics and many organic solvents and chemicals. It is ideal for petroleum products, fuels including those blended with ethanol or methanol, diesel, biodiesel, mineral oils and greases, silicone oils and greases, high vacuum, strong acids, ozone, weather and very high temperatures.

It isn't suitable for ketones, low molecular weight organic acids (e.g. Formic and acetic), super-heated steam, low molecular weight esters and ethers or phosphate based hydraulic fluids. Industry fittings have a red coloured O-ring.

HNBR (Hydrogenated Nitrile Butadiene Rubber) O-ring sealing element are utilised for the Gas press fittings. HNBR, compared to standard Nitrile, possesses superior mechanical properties and improved resistance to heat, ozone and chemicals. It is suited to propane, butane and natural gas (methane). It is not suitable for drinking water. Gas press fittings have a yellow O-ring and are clearly marked with a distinctive yellow colour and the word GAS. Whilst fuel gas standards call for working temperatures of up to 70°C, the Forza Stainless HNBR gas O-ring is certified for operating temperatures up to 100°C.

O-RING SELECTION CHART

MEDIUM APPLICATIONS	WATER EPDM	HT FKM	GAS HNBR	INDUSTRY APPLICATIONS	WATER EPDM	HT FKM	GAS HNBR
POTABLE WATER	●	●		MANUFACTURING	●	●	
NON-POTABLE WATER	●	●		SHIP BUILDING AND RAIL	●	●	●
SOLAR SYSTEM		●		INDUSTRY GENERAL AND HEAVY	●	●	●
FLOW & RETURN INDUSTRIAL FLUIDS	●	●		AUTOMOTIVE	●	●	
FUEL AND NATURAL GAS			●	MEDICAL	●	●	●
SPECIALIST AND LIQUID GAS	●	●	●	CHEMICAL	●	●	●
FIRE SPRINKLER	●			CO-GENERATION ENERGY	●	●	
FUEL OIL/HYDROCARBON		●		MINING	●	●	●
COMPRESSED AIR	●	●		FOOD AND BEVERAGE	●	●	●
STEAM		●		PULP AND PAPER	●	●	

EPDM - Ethylene Propylene Diene Monomer

FKM - Fluorocarbon Rubber

HNBR - Hydrogenated Nitrile Butadiene Rubber

2.4 GASKETS

Adaptor flange sealing, asbestos free, suitable up to maximum 400°C, resistant against water, steam, fuel, depleted liquor, oils and gases.

Please ensure that you select the appropriate gasket suitable for the application of your project.

If you are unsure of the appropriate gasket for your project, please contact the Forza Global Technical Department.

DIMENSION	STANDARD	INDUSTRY	GAS
15mm	✓	✓	✓
22 mm	✓	✓	✓
28 mm	✓	✓	✓
35 mm	✓	✓	✓
42 mm	✓	✓	✓
54 mm	✓	✓	✓
76.1 mm	✓	✓	✓
108 mm	✓	✓	✓

2.5 APPLICATIONS

To ensure the correct use of Forza Stainless Steel Press tube and fittings, please confirm with Forza Global that the tube and proposed O-ring seal materials are suitable for the application. Some typical applications are listed below:

- Fluids (cold and hot water systems, fire and sprinkler systems, fuel and oil)
- Gases (including natural gas, inert gas, fuel gas, technical gases, compressed air)
- Chemical installations
- Industrial installations (such as pump lines, brine lines, vacuum piping, oils, industrial mixtures)
- Solar installations
- Electrical conduits, and much more



2.6 THERMAL EXPANSION

Tube lines conveying hot, cold, or media of varying temperature and lines which are exposed to a high level of heat radiation, expand and contract, generating thermal movement of the system.

If the lines are constrained and subject to thermal movement, damage can result mostly in the form of fatigue failures. It is important to avoid stress concentrations between fixed points, typically found at valves and other fittings within the system.

In order to maximise the design life of the system and reduce repair and maintenance costs, sufficient space for thermal movement must be allowed for in the design and installation of the system.

The basic principle is that sufficient movement potential must always be available between two fixed points. If the line routing does not enable sufficient compensation for thermal movement, installation of specific component parts, such as axial compensator's may be considered. Incorporating expansion loops, offsets and horseshoe expansion links into the system are also a cost-effective way to accommodate thermal expansion. To enable regular maintenance inspections the installation location should be visible and easily accessible for these items.

EXPANSION DEVICES

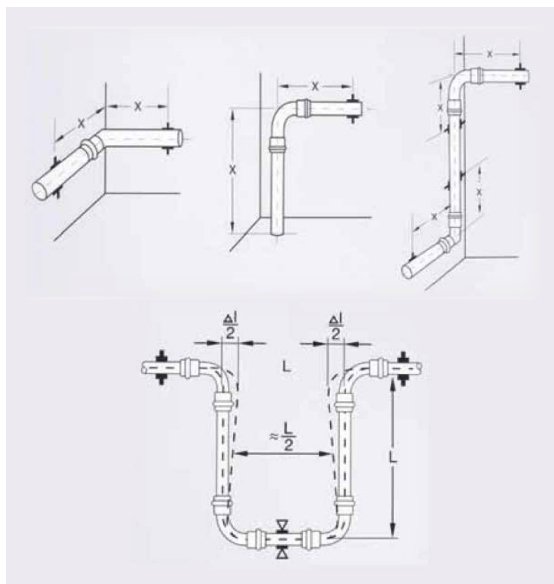

MINIMUM SIDE LENGTH "L" OF A U-BEND EXPANSION ELEMENT FOR

Tube Diameter d (mm)	Temperature Differential AL						
	10mm	20mm	30mm	40mm	50mm	60mm	70mm
15	0.33	0.46	0.57	0.65	0.73	0.80	0.87
22	0.40	0.56	0.69	0.79	0.89	0.97	1.05
28	0.45	0.63	0.77	0.89	1.00	1.10	1.18
35	0.50	0.71	0.87	1.00	1.12	1.22	1.32
42	0.55	0.77	0.95	1.10	1.22	1.34	1.45
54	0.62	0.88	1.08	1.24	1.39	1.52	1.64
76.1	0.74	1.04	1.28	1.47	1.65	1.81	1.95
108	0.88	1.24	1.52	1.76	1.96	2.15	2.32
168							

MINIMUM DISTANCE "X" TO SLIDING SUPPORTS (M) TO ALLOW FOR THERMAL EXPANSION

Tube Diameter d (mm)	Temperature Differential AL						
	10mm	20mm	30mm	40mm	50mm	60mm	70mm
15	0.57	0.80	0.98	1.13	1.27	1.39	1.50
22	0.69	0.97	1.19	1.37	1.54	1.68	1.82
28	0.77	1.10	1.34	1.55	1.73	1.90	2.05
35	0.87	1.22	1.50	1.73	1.94	2.12	2.29
42	0.95	1.35	1.64	1.90	2.12	2.32	2.51
54	1.08	1.52	1.86	2.15	2.41	2.63	2.85
76.1	1.28	1.81	2.21	2.55	2.86	3.13	3.38
108	1.52	2.15	2.63	3.04	3.40	3.73	4.02
168							

LINEAR EXPANSION FORMULA

Below table is based on potable water.

$$\Delta L = (L) (\alpha) (\Delta T)$$

ΔL = Tube Length Change in mm

L = Pipeline/Tube Length

α = Linear Thermal Expansion Coefficient (16.5×10^{-6} per °C change, for stainless steel from +20°C to +200°C)

Tube Length m	Temperature difference Δt °C							
	$\Delta t=30^\circ$	$\Delta t=40^\circ$	$\Delta t=50^\circ$	$\Delta t=60^\circ$	$\Delta t=70^\circ$	$\Delta t=80^\circ$	$\Delta t=90^\circ$	$\Delta t=100^\circ$
0.1	0.05	0.06	0.08	0.10	0.11	0.13	0.14	0.16
0.2	0.10	0.13	0.16	0.19	0.22	0.26	0.30	0.32
0.3	0.14	0.20	0.24	0.30	0.34	0.40	0.43	0.50
0.4	0.20	0.26	0.32	0.40	0.45	0.50	0.60	0.64
0.5	0.24	0.30	0.40	0.50	0.56	0.64	0.72	0.80
0.6	0.30	0.40	0.50	0.58	0.67	0.77	0.86	0.96
0.7	0.34	0.45	0.56	0.67	0.80	0.90	1.01	1.12
0.8	0.40	0.50	0.64	0.77	0.90	1.02	1.15	1.30
0.9	0.43	0.57	0.72	0.86	1.01	1.15	1.30	1.44
1.0	0.50	0.64	0.80	0.96	1.12	1.30	1.44	1.60
2.0	0.96	1.30	1.60	1.92	2.24	2.60	2.90	3.20
3.0	1.44	1.92	2.40	2.90	3.40	3.84	4.32	4.80
4.0	1.92	2.60	3.20	3.80	4.50	5.12	5.76	6.40
5.0	2.40	3.20	4.00	4.80	5.60	6.40	7.20	8.00
10.0	4.80	6.40	8.00	9.60	11.20	12.80	14.40	16.00
15.0	7.20	9.60	12.00	14.40	16.80	19.20	21.60	24.00
20.0	9.60	12.80	16.00	19.20	22.40	25.60	28.80	32.00
25.0	12.00	16.00	20.00	24.00	28.00	32.00	36.00	40.00

2.7 CORROSION RESISTANCE

INTERNAL CORROSION

Stainless steel pipework systems have a passive layer, mostly formed from chromic oxide created upon contact with oxygen or oxygenated water (i.e. drinking water). This layer inhibits corrosion from occurring and provides excellent levels of hygiene, durability and water quality.

If there are chloride levels above those deemed acceptable, a breakdown of the passive layer may occur allowing corrosion to form, pitting, crevice or stress corrosion. Crevice corrosion rarely occurs on grade 316 steel especially where the concentrations of chloride are under 1000ppm in supply and wastewater systems.

An increase with temperature has also been proven to aid in crevice and pitting corrosion. Normal potable water systems with everyday temperatures and chloride levels, should not cause a problem to the system.

Borehole water may have increased levels of chlorine, meaning more care needs to be taken ensuring the levels are within the tolerable range.

EXTERNAL CORROSION

External corrosion of stainless steel pipework occurs when exposed to high levels of chloride. Forza Stainless Press tube and fittings should not be installed in this situation. However, if there are parts of the system where this is unavoidable, appropriate precautions must be taken to minimise the risk.

Protection of External Surfaces

In areas at risk of unsuitable external conditions, protecting the piping system is of high importance. Other issues such as direct contact can be resolved by using off-set brackets, separation spacers and or other 'material separation' solutions. Covering the external surface can protect and insulate the surface from contaminants. Protection against external contaminants must be waterproof and non-porous, resistant to heat/ageing and be continuous (no gaps or damage).



2.8 INSULATION – ACOUSTIC AND THERMAL

Any lagging or insulation materials applied to the stainless steel tubes must not have a water soluble chloride ion content exceeding 0.05% by weight. Failure to ensure this may result in corrosion and a shortened life of the installed system.

Any lagging or insulation materials applied to the stainless steel tubes must not have a water soluble chloride ion content exceeding 0.05% by weight. Failure to ensure this may result in corrosion and a shortened life of the installed system.

ACOUSTIC INSULATION

Acoustic insulation is to be implemented according to standards and codes, including the National Construction Code in Australia. Tubes, including fittings, in isolation generate no noise, but supports that are poorly constructed or poorly sized can generate noise that will be transmitted on the tube work. Tubes should always be acoustically insulated against structure borne noise in wall break-through penetrations, or on installation walls using clamps with acoustic insulation. An additional option is for these lines to be run through utility shafts.

THERMAL INSULATION

Thermal insulation of tubes is to be implemented according to standards and codes, including the National Construction Code in Australia.

The thermal insulations of tubes should be implemented in accordance with national codes and standards including AS 4426.

Additionally, the following design considerations should be observed. Tube lines for cold drinking water are to be laid so that the drinking water quality is not impaired by the heat influence of the environment. A sufficient separation distance to heat sources is to be maintained, so that the lines are not influenced by these heat sources. If this is not possible, the cold water lines must be insulated against unwanted heating. In refrigeration systems, to decrease energy losses and to avoid unwanted water condensate, these lines must be water-blocking thermally-insulated. These requirements apply not only for newly built systems, but also for those laid during renovation in existing applications.

2.9 CONNECTING TO DIFFERENT METALS

Connections made between two different metals can sometimes result in what is known as a bimetallic reaction. This can be caused not only with a direct connection but water passing from one material to another. This bimetallic reaction can effect some metals.

While stainless is generally not effected by the flow rule with potable water and other nonferrous metals it is not a preferred method of installation. To combat this reaction an inert section is used to separate the other two metals another method is to use a valve made of non-ferrous material.

Stainless steel, copper and copper alloys can easily be combined without the risk of corrosion. Please note carbon steel should not be directly connected to stainless steel as this will cause corrosion. A spacer connector of brass material should be used to separate the two dissimilar materials by at least 50mm. Flow of water should be in the direction from carbon steel to stainless steel and not vice versa.

Deposits of other metals may leave a stain or discolour the tube but does not necessarily indicate corrosion.

2.10 PRESSURE LOSS & FLOW RATES

CONTINUOUS PRESSURE DROP

To calculate the resistance of a fluid flow in a straight section of a piping system, first determine the resistance in a unit of length and then multiply the total length by this value. This value can be determined analytically using the Hazen-Williams formula.

$$P = \frac{6.05 \times 10^5}{C^{1.85} \times di^{4.87}} \times Q^{1.85}$$

p = pressure drop in the pipe [bar/m]
 Q = flow through the pipe [l/min]
 di = mean internal diameter of the pipe [mm]
 C = constant for type and condition of the pipe
 (140 for Stainless Steel and Galvanised Steel)

If you wish to perform these calculations, please consult the relevant specialised literature. For the normal installation calculations, the appropriate diagrams, such as those given in the diagram on page 19, can be used to solve this problem. The unit pressure drop [R] and the flow velocity [m/s] for a given water flow rate can be determined simply and quickly in this way.

Once [R] and the actual or equivalent length of the piping system are known, the total pressure drop over the particular segment can be calculated. The diagram on page 19 gives the values that apply to water with a temperature of 80°C. It can be seen that [R] changes with temperature and, as such, a correction is needed. Graphs can be prepared for the different operating temperatures and various velocity ranges.

In addition to the temperature, water additives e.g. anti-freeze, will affect the value [R] and will need to be corrected accordingly. It would be too complex to use several diagrams to perform a calculation for each temperature. That is why the nomogram in figure 16 can be used. It gives the correction factor.

[Kc] that needs to be applied to [R] for the actual temperature of the fluids. The following example explains the use of the nomo-gram. If we assume a flow rate of 700 l/h for pipe of 22 x 1.2 mm, the value of R is 27 WS/m (± 270Pa/m) for a temperature of 80°C. Imagine that we want to calculate the value of [R] for a water temperature of 40°C. We must first find the value of [R] for this temperature and then multiply that value by the correction factor [Kc] for a temperature of 40°C.

$$R = (27 / 0.82) \times 0.89 = 29.3 \text{ mm WS/m [293 Pa/m]}$$

Pipe sizing and pressure losses

Galvanised Steel and Stainless Steel pipe:
 d 15, 18, 22, 28, 35, 42, 54, 76, 89, 108, 168

The pressure losses are calculated according to the Nikuradse formula:

$$R = 8,48455 \cdot 109 \cdot m^{1,7749} \cdot di^{-4,807}$$

Surface roughness: 0,01 mm

- R = pressure loss (Pa/m)
- \dot{m} = flow rate (l/h)
- di = pipe insider diameter (mm)

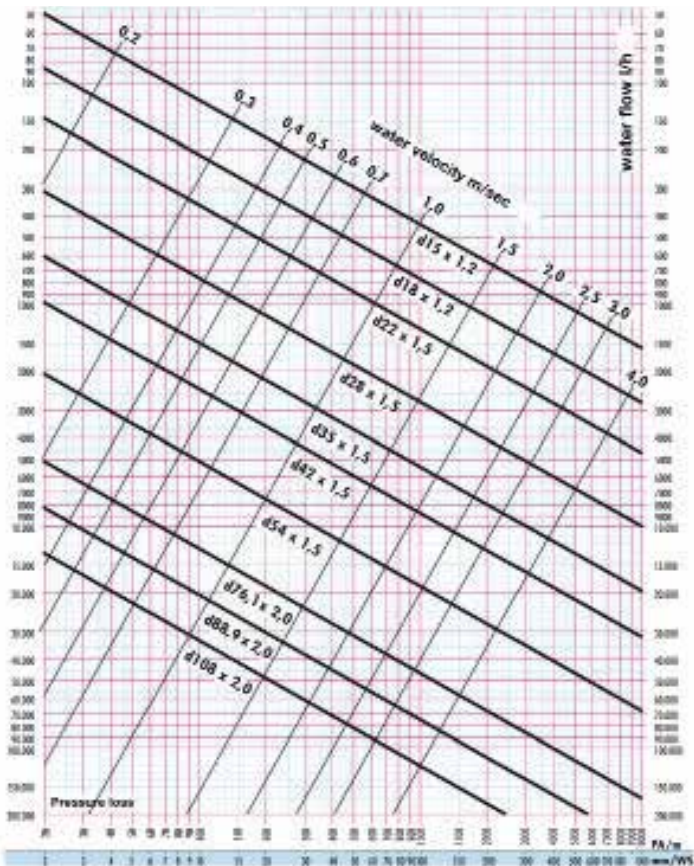

2.11 RECOMMENDED WATER VELOCITIES

Please note the maximum allowances for water velocities are per the relevant national standards and codes, which includes AS/NZS 3500.

2.12 DESIGN PRESSURES

Depending on the application variables, including the medium being conveyed, pressures and temperatures, the use of high pressure pressing tools and special jaws and slings may be required to achieve these higher pressures.

Technical applications need to be assessed by our technical department. Please provide details of required system sizing, temperature and operating pressure, medium to be conveyed plus other relevant details for an analysis and resultant recommendation.

Using other manufactures press tools could affect pressure ratings & guarantees. Forza Press Stainless Steel may be pressed with other manufacturers press tools however Forza Global gives NO guarantee for the tightness of the

press tools. The system could potentially only be rated to 16 bar. The press tools must be maintained according to the respective manufacturer guidelines.

Forza Press Stainless is safely operational at pressures in excess of the standard pressure ratings. These special applications need to be assessed by the Forza Global technical department. Please provide details of required system sizing, temperature and operating pressure, medium to be conveyed plus other relevant details for an analysis and resultant recommendation. Any Forza Press Stainless system operating above standard pressure, MUST be pressed using recommended (HP) equipment and have safety control measures installed in the system. Systems should be designed and installed suitable for the application to maintain integrity in accordance with the manufacture recommendation.

2.13 VACUUM APPLICATIONS

Forza Stainless Steel Press has been tested and approved to operate safely at up to -0.85 bar for vacuum applications.

2.14 MATERIAL COMPOSITION

316L CHEMICAL COMPOSITION		
ELEMENT		PERCENT BY WEIGHT
C	Carbon	0.030 max
Mn	Manganese	2.00 max
Si	Silicon	0.75 max
Cr	Chromium	16.00 – 18.00
Ni	Nickel	10.00 – 14.00
Mo	Molybdenum	2.00 – 3.00
P	Phosphorus	0.045 max
S	Sulfur	0.030 max
Fe	Iron	Bal.

304L CHEMICAL COMPOSITION		
ELEMENT		PERCENT BY WEIGHT
C	Carbon	0.030 max
Mn	Manganese	2.00 max
P	Phosphorus	0.045 max
S	Sulfur	0.030 max
Si	Silicon	0.75 max
Cr	Chromium	18.00 – 20.00
Ni	Nickel	8.00 – 12.00
N	Nitrogen	0.10 max
Fe	Iron	Bal.

SECTION 3 – TOOLING

3.1 RECOMMENDED PRESS TOOLING

Forza recommends the use of Novopress pressing tools for use with the Forza Stainless Steel Press system. Forza has a range of tools available which can be hired through any Forza branch throughout Australia.

High pressure applications are subject to approval by Forza Global and may require special press tools, jaws and slings.

These pressing tools and associated attachments are maintained according to the respective manufacturer's guidelines.

Forza Global assembly instructions for the system must be observed at all times.

The same tools are used for the Forza Copper V Press system, simply change adaptors and slings to suit material and press profile as required.

3.2 TOOL SELECTION

The right tool for the job...

Our fleet of tools are designed to install Forza stainless steel press-fit quickly & consistently without the need for welding or threading to form a permanent join.

We offer hire, purchasing and servicing for our Press Tools.

Our trained Sales Team can meet onsite for Press Tool training to meet your OH&S requirements and we maintain records of attendees.

Ensure the inner press surfaces are lubricated with Inox for a smooth consistent press. Reapply as needed.

PLEASE NOTE:

This chart is a guide and full specifications and instructions are available on request.

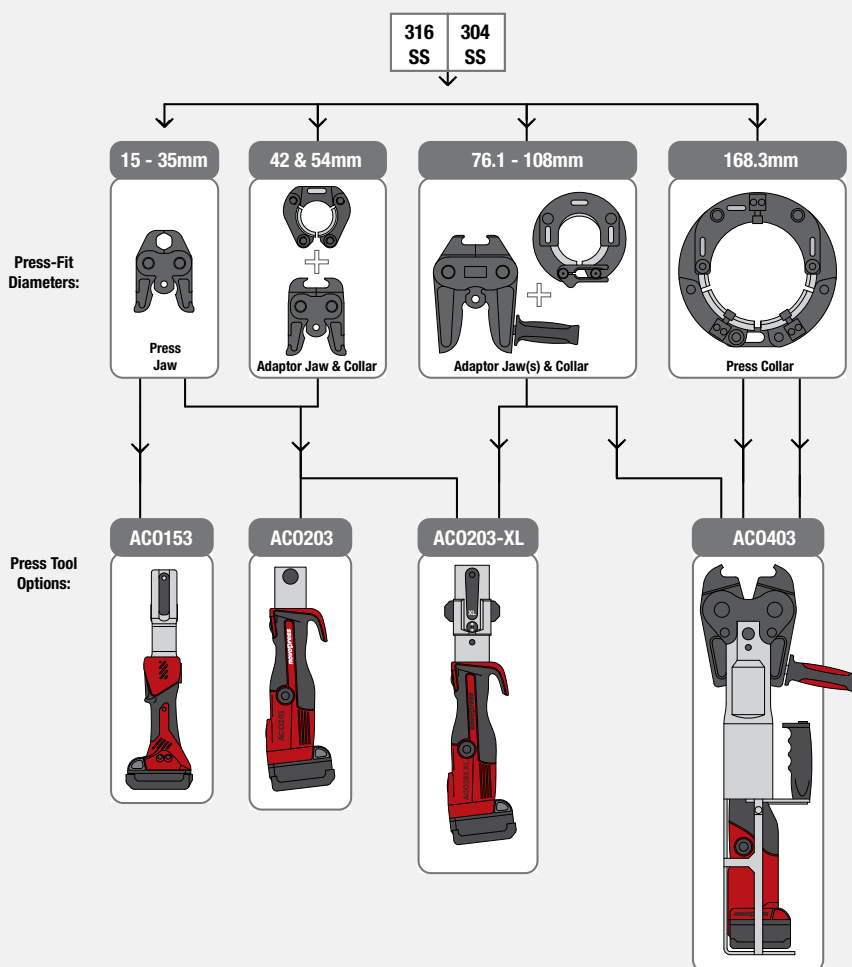

3.3 OPERATING INSTRUCTIONS

Holding the tool securely, press and hold the start button for approximately 3 seconds to begin the automatic press cycle (the green LED will go out). Release the start button and continue to hold the tool securely. The green LED will light when the press cycle is complete. To cancel the automatic press cycle, press and hold the release button on the side of the tool until the tool turns off. If the red

LED lights up, press the start button. If the tool does not run, call Forza for advice. If the red and green LEDs flash alternately, the tool is ready for a service, contact Forza to arrange. The tool will turn off automatically after 30 minutes of no use. Turn the tool ON by quickly pressing and releasing the start button and open the jaws around the fitting.

3.4 TOOLING SAFETY AND MAINTENANCE

Press tools should only be used as directed, by trained persons. Always remove the battery before performing regular cleaning and maintenance work. Keep hands away from jaws and slings while tool is in use and never operate the tool without jaws/slugs attached. Crush injuries to hands and fingers may result.

Novopress tools, jaws and slings are low maintenance, however, to ensure optimal performance and safety there are some minimum precautions and maintenance procedures that need to be followed. Carry out basic inspection of the pressing device and attachments (jaws, adaptors and slings) prior to each use to ensure they are clean and free from debris and dirt. The attachments should be visually inspected to ensure there are no cracks. If there are any cracks, do not use them, as there is risk of the attachments shattering and potential injury from flying fragments.

It is recommended to always wear appropriate eye protection whenever using the pressing device. When inspecting the pressing jaws and slings, also ensure that there are no foreign material deposits and that the contours of the pressing surfaces are in order. Failure to do this may result in incorrect joint formation and damage to the attachments and/or the pressing device. Regular application of light machine oil to the moving parts of jaws, adaptors and slings and a general application of an anti-corrosive spray is recommended to maintain serviceable condition and function.

The pressing device, attachments and batteries must be serviced at least within 35,000 presses for the Novopress. It is recommended to have the press tool, jaws, adaptor jaws and slings inspected at least once per year. There are costs associated with this service work. Failure to have the required services carried out may affect the warranty.

Any service or repair of the Novopress® pressing tool or jaws, requiring opening the device, or mechanical repairs, shall only be carried out by an authorised agent. Failure to do so may void the warranty.

The Forza service and repair program is easy, ensures minimal down time and provides known maximum costs for repairs.

The key components of the program include:

- Loan tools available while your tool is being serviced/ repaired
- Convenient and easy process for lodging your tool for service/repair via Forza
- You will be notified of the cost of service/repair for confirmation before any work is commenced

SECTION 4 – INSTALLATION GUIDELINES

4.1 HANDLING AND STORAGE

In the storage and transport of tubes and fittings, damage and contamination, including physical damage from building site activity, swarf, other building materials, soil and stormwater must be avoided. It is recommended to transport and store the tubes carefully, preferably on squared timbers and ensuring no risk of damage from heavy objects falling or resting on them. The tubes and fittings shall be stored dry and not placed directly on the ground. Fittings are to be taken from the original packaging only directly prior to installation.

4.2 TUBE CUTTING AND DE-BURRING

It is recommended to use a tube cutter to cut Forza Stainless Steel tubes to ensure a clean and right angled cut. The tube cutter shall not have been used for cutting carbon steel/ferrous metals and should have a Stainless Steel cutting blade. Failure to ensure this may result in a corrosion failure point. If electrical saws are used for cutting Forza Stainless tubes, the cutting speed needs to be carefully controlled to ensure no sensitization of the material occurs.

Experience indicates that even a straw-yellow discoloration of the stainless steel can indicate a sensitization of the material. If annealing colours appear, the affected sections must be eliminated and the remaining stainless steel tube surfaces shall be carefully checked. Purpose designed planetary saws, for cutting stainless steel tubes, are ideal for cutting higher volumes of tubes and larger sizes, as they simultaneously de-burr as they cut. The utilization of high speed cutting disks, angle grinders or flame cutters is not allowed for cutting stainless steel tubes. After cutting, the tube ends are to be carefully de-burred inside and outside using a tube de-burring tool or suitable hand file.

4.3 TUBE BENDING

Hot bending of stainless steel tubes is not allowed as it will adversely affect the composition of the stainless steel, compromising performance. Forza Stainless tubes up to and including dimension 28 mm must be cold bent with suitable bending tools. A bending radius of at least $r = 3.5 \times d$ is to be maintained. After bending, a sufficiently long tube section is required to fit connections. Larger size tubes are not to be bent.

4.4 INSERTION DEPTHS

There are minimum spacing insertion depths to be adhered to with the Forza Stainless press fittings. These minimum distances are required to ensure correct formation of the joints. Please refer to the following drawings and tables.

FORZA INSERTION DEPTH	
TUBE OD MM	INSERTION DEPTH MM
15	22
22	24
28	24
35	28
42	38
54	41
76.1	60
108	75
168	116

4.5 DISTANCES BETWEEN FITTINGS

There minimum spacing requirements between two press fittings and from wall/floor penetrations to press fittings. These minimum distances are required to ensure proper use of the pressing tools and to facilitate correct formation of the joints. Please refer to the following drawings and tables.

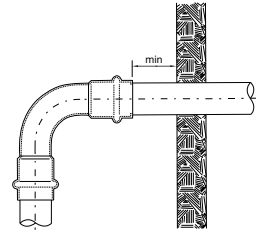
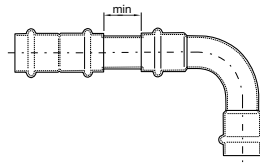

CLEARANCE BETWEEN TWO PRESS FITTINGS

FITTING SIZE	MINIMUM CLEARANCE MM
DN15	10
DN22	10
DN28	10
DN35	10
DN42	20
DN54	20
DN76.1	30
DN108	30
DN168	60

CLEARANCE BETWEEN PRESS FITTING AND WALL

FITTING SIZE	MINIMUM CLEARANCE MM
DN15	60
DN22	60
DN28	60
DN35	60
DN42	60
DN54	60
DN76.1	60
DN108	60
DN168	70

4.6

PRESS TOOL SPACE REQUIREMENTS

The illustration and table below provides information regarding the required space to safely and effectively complete press cycles with tools using either jaws and slings during the installation of the Forza Stainless press tubes and fittings.

TOOL SPACE REQUIREMENTS RELATIVE TO WALLS AND OTHER TUBES

Tube Size OD mm	A mm	B mm	C mm	D mm	E mm	F mm
15 Jaw	20	56	32	40	80	155
22 Jaw	25	65	32	50	82	175
28 Jaw & HP Sling	25	75	32	54	82	182
35 Jaw	30	83	32	65	85	205
35 HP Sling	75	95	75	75	95	205
42 HP Sling	75	140	85	110	155	375
54 HP Sling	85	150	90	110	155	375
76.1 HP Sling	115	220	120	200	220	650
108 HP Sling	150	255	150	200	255	650
168 Sling	200	335	200	200	335	850

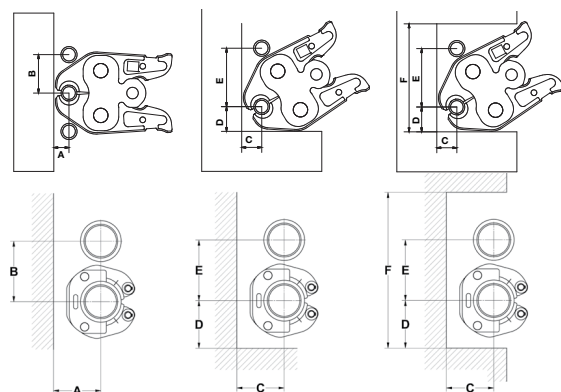

4.7 INSTALLATION

The procedure for coupling Forza Stainless tube and Forza Stainless fittings is shown in images below. Please note that for high pressure applications specific press tools, jaws and HP slings may be required. The tube ends must be clean for the

creation of trouble-free press connections. The tube exterior surfaces shall have no scratches or grooves in the section of tube end being inserted into a socket for press fitting.

DN15-54



With the use of a tube cutter, cut stainless tube to the desired length.

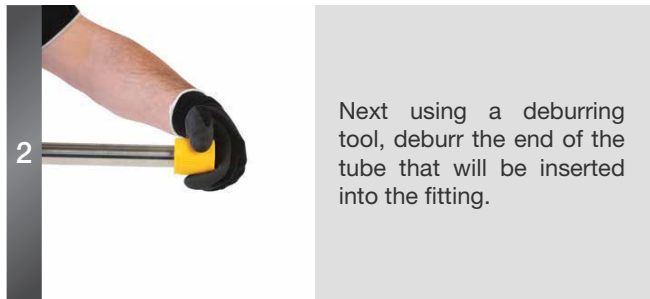

Next using a deburring tool, deburr the end of the tube that will be inserted into the fitting.



Check that you have the correct fitting for the application. Water will have a black 'O' ring, gas will have a yellow 'O' ring and High temp. will have a red 'O' ring.



Line up tube with fitting and place a mark on the tube at the correct insertion depth.

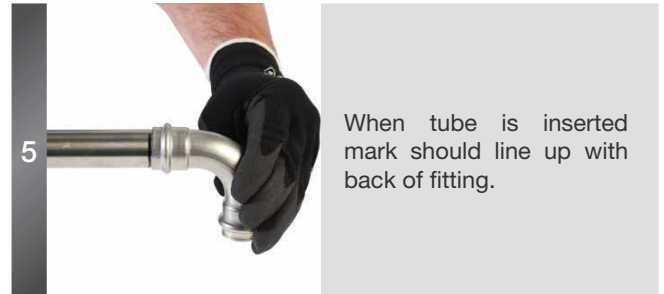

When tube is inserted mark should line up with back of fitting.



Insert the correct size press jaw for the size of fitting being pressed. Ensure jaw is clean and moves freely.



Line up the jaw of the tool so the centre of the jaw lines up with the raised section of the fitting.



Press the trigger on the tool, hold down until jaws fully close and an audible click is heard. This completes the pressing process.

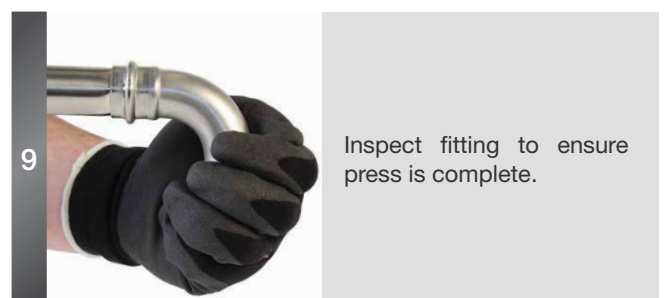

Inspect fitting to ensure press is complete.

DN76.1 - 168



1 Using a fine tooth saw or tube cutter, cut stainless tube to the desired length.



2 Using a smooth file deburr and clean the end of the tube both internally and externally to minimise turbulence and pressure loss. This will also avoid damage to the O-ring.



3 Check fitting to ensure it is suitable for the application. Confirm that fitting is clean and the O-ring is free from debris.



4 Line up the fitting with the tube and place a mark on the tube at the correct insertion depth.



5 Place fitting onto tube ensuring the mark on the tube lines up with the outer edge of the fitting.



6 Select the correct sized collar, making sure that pressing area is clean and smooth.

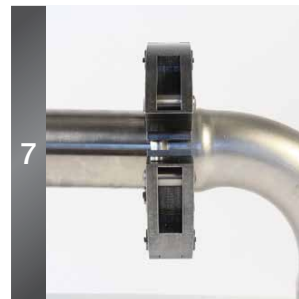

7 Place the collar over the fitting and check that the fitting sits squarely inside the pressing area of collar.



8 Place the adaptor jaw in the tool and ensure pin is pushed into place to hold jaw.



9 Place the adaptor jaw over the pins on the collar, check that the fitting is still matching up to the insertion depth mark on the tube. Press the trigger on the tool and hold down until piston retracts. Remove the adaptor jaw from the collar, then the collar from the fitting.

4.8 TUBE FIXING AND SUPPORT

Please refer to the relevant national standards and/or codes, such as AS/NZS 3500, to determine the requirements for tube fixing and support. Tubes are to be connected directly to the building by means of standard brackets, clips and hangers and must not be attached to other lines. In order to fulfil acoustic protection requirements, clamps with appropriate elastomeric inserts are to be employed. Clamps are always to be attached on the tube only, not on the fittings.



SECTION 5 – COMMISSIONING, MAINTENANCE & WARRANTIES

5.1 TESTING

All testing of the system needs to be in accordance with AS/NZS 3500 as mentioned in the installation instructions. If the system needs to be drained after testing it is not advisable to test with water. Air is the preference as this will lower the risk of the test causing unwanted pitting and corrosion. The following two options are preferred methods. The one you choose will depend on which test is best suited to the installation.

1. Testing with Water: Potable water is recommended.

Flush the system then fill with potable water so that it is free from air pockets before commencing the test. If connecting to an existing water supply, flush any connecting pipework before connection to prevent the introduction of dirt, swarf or contaminants.

It is important to ensure that the system remains full following a water pressure test, systems that are drained or partially drained will have increased risk of pitting corrosion.

2. Testing with Air: Use oil-free air or an inert gas such as carbon dioxide or nitrogen.

(For safety reasons oxygen or other flammable gasses are not to be used.)

3. LPG and Natural Gas Systems: Conduct the pressure test of the system in accordance with AS/NZ 5601. Water is not a suitable medium for testing, utilise the air testing method outlined above.

5.2 DISINFECTION

Stainless steel tubes can be disinfected with hydrogen peroxide H₂O₂ as per the Australian Drinking Water Guidelines(ADWG), although disinfection with *chlorine is possible.

*Correct guidelines for using chlorine in a stainless system must be used

The thermal disinfection of stainless steel lines can be carried out at high temperatures. The temperature is limited to 120°C in case of standard Forza Stainless fittings because of the EPDM O-rings. However, there is no restriction on the disinfection duration.

5.3 DE-SCALING

Lime scale on the inside bore of tubes can be caused by a variety of service conditions including, high water temperatures or excessively hard water quality.

Additives for de-scaling tubes must be checked for suitability with the pipe material, rubber seal ring and approved for use with Forza before use.

When using any solution, ensure the system is flushed correctly and the manufacturer's instructions are followed in an accurate and safe manner at all times.

5.4 COMMISSIONING

The user, or owner, of the system is under an obligation to ensure the system is maintained in a serviceable and safe condition at all times.

The system must be operated in such a way that faults and other factors affecting the reliability of the system are resolved before a hazard or issue occurs.

Ongoing maintenance includes the assessment of both the exterior and interior of the pipework with regular inspections and timely, effective rectification if required.

Avoid damage by keeping the system clean and free of contaminants, protect from sparks, grindings and confirm changes in media before making changes to operating conditions.

It is recommended that the user enter into a maintenance agreement with an installation contractor who is familiar with the product and application installed.



5.5 FORZA STAINLESS STEEL PRESS TUBE AND FITTINGS WARRANTY



**ApprovalMark
International**

CERTIFICATE OF CONFORMITY

ApprovalMark International hereby grants:

Forza Global Pty Ltd
2/8 Barclay Road,
Derrimut 3030
AUSTRALIA

WaterMark Certificate of Conformity – Level 1
Evaluated to:
ATS 5200.053: 2008 - Plumbing and drainage products - Stainless steel pipes and tubes for pressure application

The WaterMark licensee shall comply with all the terms and conditions as stipulated by the governance of the operating rules of WaterMark, and shall comply with standard requirement at all times including when standard is amended. The WaterMark license only covers the product which is identified in the product schedule.

Certificate No. WM 74655

Issued: 14th December 2016	Originally Certified: 14th December 2016
Expires: 14th December 2021	Current Certification: 14th December 2016



John PRASAD
Certification Manager



ApprovalMark Certification



WaterMark

ApprovalMark



CERTIFICATE OF CONFORMITY

ApprovalMark International hereby grants:

Forza Global Pty Ltd
2/8 Barclay Road,
Derrimut 3030
AUSTRALIA

WaterMark Certificate of Conformity – Level 1

Evaluated to:

AS 3688: 2016 - Water supply and gas systems - Metallic fittings and end-connectors

The WaterMark licensee shall comply with all the terms and conditions as stipulated by the governance of the operating rules of WaterMark, and shall comply with standard requirement at all times including when standard is amended. The WaterMark license only covers the product which is identified in the product schedule.

Certificate No. WM 74656

Issued: 6th December 2016

Expires: 6th December 2021

Originally Certified: 6th December 2016

Current Certification: 6th December 2016

John PRASAD
Certification Manager



ApprovalMark Certification



WaterMark

ApprovalMark



Forza Stainless "V" Press tube and fittings are guaranteed against manufacturing defects for a period of 25 YEARS when installed and used in accordance of the Australian Plumbing code and or the LOCAL or STATE Authority and when installed by a licensed PLUMBER.



Forza Stainless tube complies with the standards as set out in AS5200.53:2008 Stainless steel pipes and tubes for pressure applications.

Forza Stainless "V" Press fittings complies with the standards as set out in AS3688:2016 Water Supply and gas systems - Metallic fittings and end connectors.

a product by



Certificate of Currency

PUBLIC AND PRODUCTS LIABILITY POLICY

INSURED: Forza Global Pty Ltd
BUSINESS ACTIVITY: Import and wholesale of plumbing fixtures, pipes, valves and tools
POLICY NUMBER: BXLC-LIM-2018-002733
PERIOD OF INSURANCE: 22/01/20 to 22/01/21 At 4pm Local Time
LIMIT OF INDEMNITY:

	Limit	Excess
Public Liability	\$50,000,000 any one occurrence	\$2,500 each and every Claim (inclusive of costs and expenses)
Products Liability	\$50,000,000 any one occurrence and in the aggregate for all Injury or Damage occurring during the Period of Insurance	\$2,500 each and every Claim (inclusive of costs and expenses)
Special Excess	\$25,000 each and every occurrence (inclusive of costs and expenses) in respect of Injury to Contractors, Sub-Contractors or Labour Hire Personnel	

Signed for and on behalf of XL Insurance Company SE, Australia branch (ABN 36 083 570 441), trading as Brooklyn Underwriting:

T: +61 2 8270 1790
 F: +61 2 9252 2538
 W: brooklynunderwriting.com.au

GPO Box 4668
 Sydney NSW 2001

Angel Place, Level 28
 123 Pitt Street
 Sydney NSW 2000

XL Insurance Company SE, Australia branch (ABN 36 083 570 441), trading as Brooklyn Underwriting

SECTION 6 – PRODUCT RANGE

6.1 FITTINGS

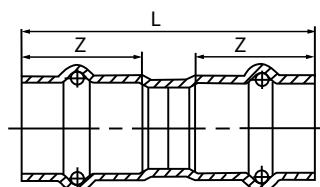

COUPLING

SIZE	EPDM CODE 304	FKM-R CODE 304	HNBR CODE 304	EPDM CODE 316	FKM-R CODE 316	HNBR CODE 316	L	Z
15mm	FSPWC15.2	FSPHTC15.2	FSPGC15.2	FSPWC15.1	FSPHTC15.1	FSPGC15.1	57	22
22mm	FSPWC22.2	FSPHTC22.2	FSPGC22.2	FSPWC22.1	FSPHTC22.1	FSPGC22.1	59	24
28mm	FSPWC28.2	FSPHTC28.2	FSPGC28.2	FSPWC28.1	FSPHTC28.1	FSPGC28.1	61	24
35mm	FSPWC35.2	FSPHTC35.2	FSPGC35.2	FSPWC35.1	FSPHTC35.1	FSPGC35.1	71	28
42mm	FSPWC42.2	FSPHTC42.2	FSPGC42.2	FSPWC42.1	FSPHTC42.1	FSPGC42.1	92	38
54mm	FSPWC54.2	FSPHTC54.2	FSPGC54.2	FSPWC54.1	FSPHTC54.1	FSPGC54.1	99	41

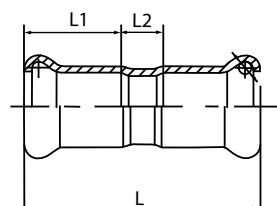

COUPLING

SIZE	EPDM CODE 304	FKM-R CODE 304	HNBR CODE 304	EPDM CODE 316	FKM-R CODE 316	HNBR CODE 316	L	L1	L2
76mm	FSPWC76.2	FSPHTC76.2	FSPGC76.2	FSPWC76.1	FSPHTC76.1	FSPGC76.1	149	60	28
108mm	FSPWC108.2	FSPHTSC108.2	FSPGC108.2	FSPWC108.1	FSPHTC108.1	FSPGC108.1	195	75	44
168mm	-	-	-	FSPWC168.1	FSPHTC168.1	FSPGC168.1	300	116	68

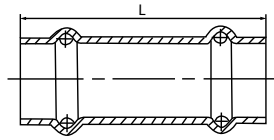

SLIP COUPLING

SIZE	EPDM CODE 304	FKM-R CODE 304	HNBR CODE 304	EPDM CODE 316	FKM-R CODE 316	HNBR CODE 316	L
15mm	FSPWSC15.2	FSPHTSC15.2	FSPGSC15.2	FSPWSC15.1	FSPHTSC15.1	FSPGSC15.1	81
22mm	FSPWSC22.2	FSPHTSC22.2	FSPGSC22.2	FSPWSC22.1	FSPHTSC22.1	FSPGSC22.1	86
28mm	FSPWSC28.2	FSPHTSC28.2	FSPGSC28.2	FSPWSC28.1	FSPHTSC28.1	FSPGSC28.1	96
35mm	FSPWSC35.2	FSPHTSC35.2	FSPGSC35.2	FSPWSC35.1	FSPHTSC35.1	FSPGSC35.1	109
42mm	FSPWSC42.2	FSPHTSC42.2	FSPGSC42.2	FSPWSC42.1	FSPHTSC42.1	FSPGSC42.1	122
54mm	FSPWSC54.2	FSPHTSC54.2	FSPGSC54.2	FSPWSC54.1	FSPHTSC54.1	FSPGSC54.1	135

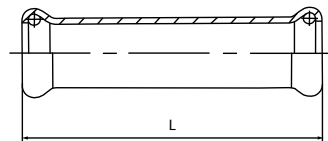

SLIP COUPLING

SIZE	EPDM CODE 304	FKM-R CODE 304	HNBR CODE 304	EPDM CODE 316	FKM-R CODE 316	HNBR CODE 316	L
76mm	FSPWSC76.2	FSPHTSC76.2	FSPGSC76.2	FSPWSC76.1	FSPHTSC76.1	FSPGSC76.1	149
108mm	FSPWSC108.2	FSPHTSC108.2	FSPGSC108.2	FSPWSC108.1	FSPHTSC108.1	FSPGSC108.1	195

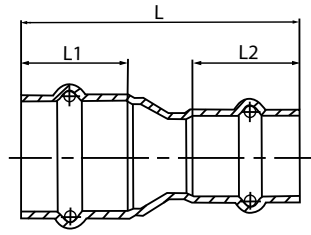

REDUCING COUPLING

SIZE	EPDM CODE 304	FKM-R CODE 304	HNBR CODE 304	EPDM CODE 316	FKM-R CODE 316	HNBR CODE 316	L	L1	L2
22x15mm	FSPWRC2215.2	FSPHTRC2815.2	FSPGRC2215.2	FSPWRC2215.1	FSPHTRC2215.1	FSPGRC2215.1	68	24	22
28x15mm	FSPWRC2815.2	FSPHTRC2815.2	FSPGRC2815.2	FSPWRC2815.1	FSPHTRC2815.1	FSPGRC2815.1	70	24	22
28x22mm	FSPWRC2822.2	FSPHTRC2822.2	FSPGRC2822.2	FSPWRC2822.1	FSPHTRC2822.1	FSPGRC2822.1	74	24	24
35x22mm	FSPWRC3522.2	FSPHTRC3522.2	FSPGRC3522.2	FSPWRC3522.1	FSPHTRC3522.1	FSPGRC3522.1	93	28	24
35x28mm	FSPWRC3528.2	FSPHTRC3528.2	FSPGRC3528.2	FSPWRC3528.1	FSPHTRC3528.1	FSPGRC3528.1	81	28	24
42x22mm	FSPWRC4222.2	FSPHTRC4222.2	FSPGRC4222.2	FSPWRC4222.1	FSPHTRC4222.1	FSPGRC4222.1	87	38	24
42x28mm	FSPWRC4228.2	FSPHTRC4228.2	FSPGRC4228.2	FSPWRC4228.1	FSPHTRC4228.1	FSPGRC4228.1	111	38	24
42x35mm	FSPWRC4235.2	FSPHTRC4235.2	FSPGRC4235.2	FSPWRC4235.1	FSPHTRC4235.1	FSPGRC4235.1	99	38	28
54x28mm	FSPWRC5428.2	FSPHTRC5428.2	FSPGRC5428.2	FSPWRC5428.1	FSPHTRC5428.1	FSPGRC5428.1	91	41	24
54x35mm	FSPWRC5435.2	FSPHTRC5435.2	FSPGRC5435.2	FSPWRC5435.1	FSPHTRC5435.1	FSPGRC5435.1	96	41	28
54x42mm	FSPWRC5442.2	FSPHTRC5442.2	FSPGRC5442.2	FSPWRC5442.1	FSPHTRC5442.1	FSPGRC5442.1	110	36	31

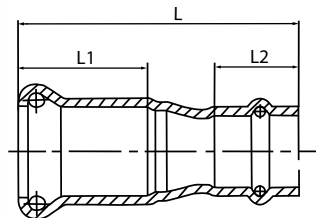

REDUCING COUPLING

SIZE	EPDM CODE 304	FKM-R CODE 304	HNBR CODE 304	EPDM CODE 316	FKM-R CODE 316	HNBR CODE 316	L	L1	L2
76x54mm	FSPWRC7654.2	FSPHTRC7654.2	FSPGRC7654.2	FSPWRC7654.1	FSPHTRC7654.1	FSPGRC7654.1	159	60.5	41
108x54mm	FSPWRC10854.2	FSPHTRC10854.2	FSPGRC10854.2	FSPWRC10854.1	FSPHTRC10854.1	FSPGRC10854.1	195	75.5	41

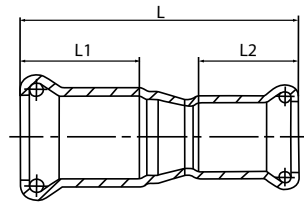

REDUCING COUPLING

SIZE	EPDM CODE 304	FKM-R CODE 304	HNBR CODE 304	EPDM CODE 316	FKM-R CODE 316	HNBR CODE 316	L	L1	L2
108x76mm	FSPWRC10876.2	FSPHTRC10876.2	FSPGRC10876.2	FSPWRC10876.1	FSPHTRC10876.1	FSPGRC10876.1	217	75.5	60

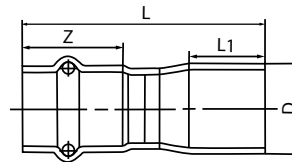

REDUCER

SIZE	EPDM CODE 304	FKM-R CODE 304	HNBR CODE 304	EPDM CODE 316	FKM-R CODE 316	HNBR CODE 316	L	L1	L2	D
22x15mm	FSPWRMF2215.2	FSPHTRMF2215.2	FSPGRMF2215.2	FSPWRMF2215.1	FSPHTRMF2215.1	FSPGRMF2215.1	66	22	30	22
28x15mm	FSPWRMF2815.2	FSPHTRMF2815.2	FSPGRMF2815.2	FSPWRMF2815.1	FSPHTRMF2815.1	FSPGRMF2815.1	75	22	31	28
28x22mm	FSPWRMF2822.2	FSPHTRMF2822.2	FSPGRMF2822.2	FSPWRMF2822.1	FSPHTRMF2822.1	FSPGRMF2822.1	66	24	31	28
35x22mm	FSPWRMF3522.2	FSPHTRMF3522.2	FSPGRMF3522.2	FSPWRMF3522.1	FSPHTRMF3522.1	FSPGRMF3522.1	77	24	34	35
35x28mm	FSPWRMF3528.2	FSPHTRMF3528.2	FSPGRMF3528.2	FSPWRMF3528.1	FSPHTRMF3528.1	FSPGRMF3528.1	73	24	34	35
42x22mm	FSPWRMF4222.2	FSPHTRMF4222.2	FSPGRMF4222.2	FSPWRMF4222.1	FSPHTRMF4222.1	FSPGRMF4222.1	93	24	44	42
42x28mm	FSPWRMF4228.2	FSPHTRMF4228.2	FSPGRMF4228.2	FSPWRMF4228.1	FSPHTRMF4228.1	FSPGRMF4228.1	92	24	44	42
42x35mm	FSPWRMF4235.2	FSPHTRMF4235.2	FSPGRMF4235.2	FSPWRMF4235.1	FSPHTRMF4235.1	FSPGRMF4235.1	88	28	44	42
54x28mm	FSPWRMF5428.2	FSPHTRMF5428.2	FSPGRMF5428.2	FSPWRMF5428.1	FSPHTRMF5428.1	FSPGRMF5428.1	100	24	51	54
54x35mm	FSPWRMF5435.2	FSPHTRMF5435.2	FSPGRMF5435.2	FSPWRMF5435.1	FSPHTRMF5435.1	FSPGRMF5435.1	108	28	48	54
54x42mm	FSPWRMF5442.2	FSPHTRMF5442.2	FSPGRMF5442.2	FSPWRMF5442.1	FSPHTRMF5442.1	FSPGRMF5442.1	113	38	48	54
76x54mm	FSPWRMF7654.2	FSPHTRMF7654.2	FSPGRMF7654.2	FSPWRMF7654.1	FSPHTRMF7654.1	FSPGRMF7654.1	146	41	75	76.1
108x54mm	FSPWRMF10854.2	FSPHTRMF10854.2	FSPGRMF10854.2	FSPWRMF10854.1	FSPHTRMF10854.1	FSPGRMF10854.1	210	41	90	108

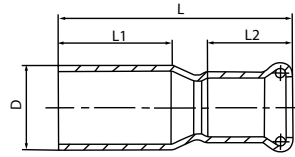

REDUCER

SIZE	EPDM CODE 304	FKM-R CODE 304	HNBR CODE 304	EPDM CODE 316	FKM-R CODE 316	HNBR CODE 316	L	L2	L1	D
108x76mm	FSPWRMF10876.2	FSPHTRMF10876.2	FSPGRMF10876.2	FSPWRMF10876.1	FSPHTRMF10876.1	FSPGRMF10876.1	196	60	90	108
168x108mm	-	-	-	FSPWRMF168108.1	FSPHTRMF168108.1	FSPGRMF168108.1	375	75.5	170	168

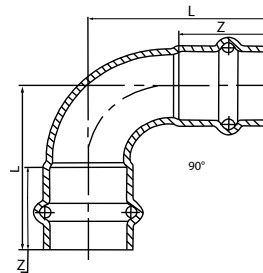

ELBOW

SIZE	EPDM CODE 304	FKM-R CODE 304	HNBR CODE 304	EPDM CODE 316	FKM-R CODE 316	HNBR CODE 316	L	Z
15mm	FSPWE15.2	FSPHTE15.2	FSPGE15.2	FSPWE15.1	FSPWE15.2	FSPGE15.1	46	22
22mm	FSPWE22.2	FSPHTE22.2	FSPGE22.2	FSPWE22.1	FSPWE22.2	FSPGE22.1	55	24
28mm	FSPWE28.2	FSPHTE28.2	FSPGE28.2	FSPWE28.1	FSPWE28.2	FSPGE28.1	66	24
35mm	FSPWE35.2	FSPHTE35.2	FSPGE35.2	FSPWE35.1	FSPWE35.2	FSPGE35.1	79	28
42mm	FSPWE42.2	FSPHTE42.2	FSPGE42.2	FSPWE42.1	FSPWE42.2	FSPGE42.1	101	38
54mm	FSPWE54.2	FSPHTE54.2	FSPGE54.2	FSPWE54.1	FSPWE54.2	FSPGE54.1	120	41

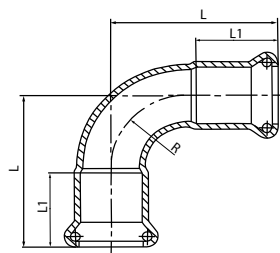

ELBOW

SIZE	EPDM CODE 304	FKM-R CODE 304	HNBR CODE 304	EPDM CODE 316	FKM-R CODE 316	HNBR CODE 316	L	L1
76mm	FSPWE76.2	FSPHTE76.2	FSPGE76.2	FSPWE76.1	FSPHTE76.1	FSPGE76.1	188.5	60.5
108mm	FSPWE108.2	FSPHTE108.2	FSPGE108.2	FSPWE108.1	FSPHTE108.1	FSPGE108.1	259.5	75.5
168mm	-	-	-	FSPWE168.1	FSPHTE168.1	FSPGE168.1	375	116

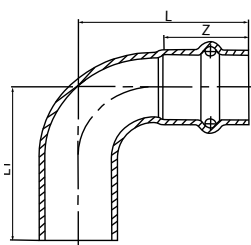

ELBOW M + F

SIZE	EPDM CODE 304	FKM-R CODE 304	HNBR CODE 304	EPDM CODE 316	FKM-R CODE 316	HNBR CODE 316	L	Z	L1
15mm	FSPWEMF15.2	FSPHTEMF15.2	FSPGEMF15.2	FSPWEMF15.1	FSPHTEMF15.1	FSPGEMF15.1	46	22	53
22mm	FSPWEMF22.2	FSPHTEMF22.2	FSPGEMF22.2	FSPWEMF22.1	FSPHTEMF22.1	FSPGEMF22.1	55	24	63
28mm	FSPWEMF28.2	FSPHTEMF28.2	FSPGEMF28.2	FSPWEMF28.1	FSPHTEMF28.1	FSPGEMF28.1	66	24	74
35mm	FSPWEMF35.2	FSPHTEMF35.2	FSPGEMF35.2	FSPWEMF35.1	FSPHTEMF35.1	FSPGEMF35.1	79	28	85
42mm	FSPWEMF42.2	FSPHTEMF42.2	FSPGEMF42.2	FSPWEMF42.1	FSPHTEMF42.1	FSPGEMF42.1	101	38	107
54mm	FSPWEMF54.2	FSPHTEMF54.2	FSPGEMF54.2	FSPWEMF54.1	FSPHTEMF54.1	FSPGEMF54.1	120	41	125

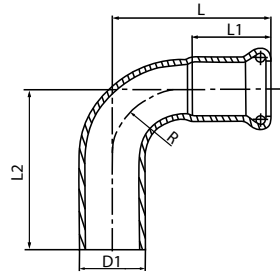

ELBOW M + F

SIZE	EPDM CODE 304	FKM-R CODE 304	HNBR CODE 304	EPDM CODE 316	FKM-R CODE 316	HNBR CODE 316	D1	L	L1	L2
76mm	FSPWEMF76.2	FSPHTEMF76.2	FSPGEMF76.2	FSPWEMF76.1	FSPHTEMF76.1	FSPGEMF76.1	76.1	188.5	60.5	189
108mm	FSPWEMF108.2	FSPHTEMF108.2	FSPGEMF108.2	FSPWEMF108.2	FSPHTEMF108.1	FSPGEMF108.1	108	259.5	75.5	252

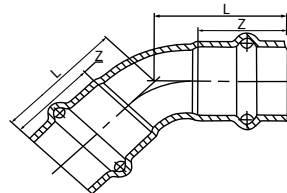

45° ELBOW

SIZE	EPDM CODE 304	FKM-R CODE 304	HNBR CODE 304	EPDM CODE 316	FKM-R CODE 316	HNBR CODE 316	L	Z
15mmx45°	FSPW45E15.2	FSPHT45E15.2	FSPG45E15.2	FSPW45E15.1	FSPHT45E15.1	FSPG45E15.1	35	22
22mmx45°	FSPW45E22.2	FSPHT45E22.2	FSPG45E22.2	FSPW45E22.1	FSPHT45E22.2	FSPG45E22.1	40	24
28mmx45°	FSPW45E28.2	FSPHT45E28.2	FSPG45E28.2	FSPW45E28.1	FSPHT45E28.1	FSPG45E28.1	45	24
35mmx45°	FSPW45E32.2	FSPHT45E32.2	FSPG45E35.2	FSPW45E32.1	FSPHT45E32.1	FSPG45E35.1	70	28
42mmx45°	FSPW45E42.2	FSPHT45E42.2	FSPG45E42.2	FSPW45E42.1	FSPHT45E42.1	FSPG45E42.1	70	38
54mmx45°	FSPW45E54.2	FSPHT45E54.2	FSPG45E54.2	FSPW45E54.1	FSPHT45E54.1	FSPG45E54.1	81	41

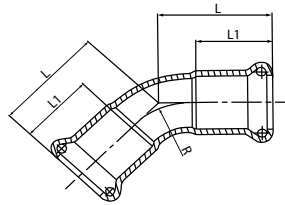

45° ELBOW

SIZE	EPDM CODE 304	FKM-R CODE 304	HNBR CODE 304	EPDM CODE 316	FKM-R CODE 316	HNBR CODE 316	L	L1
76mmx45°	FSPW45E76.2	FSPW45E76.2	FSPG45E76.2	FSPW45E76.1	FSPHT45E76.1	FSPG45E76.1	121.5	60.5
108mmx45°	FSPW45E108.2	FSPW45E108.2	FSPG45E108.2	FSPW45E108.1	FSPHT45E108.1	FSPG45E108.1	164.5	75.5
168mmx45°	-	-	-	FSPW45E168.1	FSPHT45E168.1	FSPG45E168.1	241	116

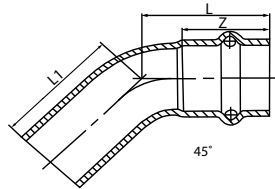

45° ELBOW M + F

SIZE	EPDM CODE 304	FKM-R CODE 304	HNBR CODE 304	EPDM CODE 316	FKM-R CODE 316	HNBR CODE 316	L	Z	L1
15mmx45°	FSPW45EMF15.2	FSPHT45EMF15.2	FSPG45EMF15.2	FSPW45EMF15.1	FSPHT45EMF15.1	FSPG45EMF15.1	35	22	42
22mmx45°	FSPW45EMF22.2	FSPHT45EMF22.2	FSPG45EMF22.2	FSPW45EMF22.1	FSPHT45EMF22.1	FSPG45EMF22.1	40	24	47
28mmx45°	FSPW45EMF28.2	FSPHT45EMF28.2	FSPG45EMF28.2	FSPW45EMF28.1	FSPHT45EMF28.1	FSPG45EMF28.1	45	24	52
35mmx45°	FSPW45EMF35.2	FSPHT45EMF35.2	FSPG45EMF35.2	FSPW45EMF35.1	FSPHT45EMF35.1	FSPG45EMF35.1	53	28	59
42mmx45°	FSPW45EMF42.2	FSPHT45EMF42.2	FSPG45EMF42.2	FSPW45EMF42.1	FSPHT45EMF42.1	FSPG45EMF42.1	70	38	75
54mmx45°	FSPW45EMF54.2	FSPHT45EMF54.2	FSPG45EMF54.2	FSPW45EMF54.1	FSPHT45EMF54.1	FSPG45EMF54.1	81	41	85

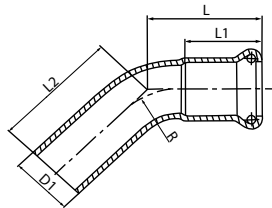

45° ELBOW M + F

SIZE	EPDM CODE 304	FKM-R CODE 304	HNBR CODE 304	EPDM CODE 316	FKM-R CODE 316	HNBR CODE 316	D1	L	L1	L2
76mmx45°	FSPW45EMF76.2	FSPHT45EMF76.2	FSPG45EMF76.2	FSPW45EMF76.1	FSPHT45EMF76.2	FSPG45EMF76.1	76.1	121.5	60.5	122
108mmx45°	FSPW45EMF108.2	FSPHT45EMF108.2	FSPG45EMF108.2	FSPW45EMF108.1	FSPHT45EMF108.2	FSPG45EMF108.1	108	164.5	75.5	157

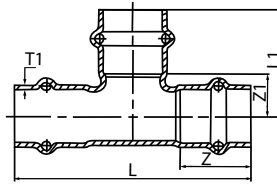

EQUAL TEE

SIZE	EPDM CODE 304	FKM-R CODE 304	HNBR CODE 304	EPDM CODE 316	FKM-R CODE 316	HNBR CODE 316	L	Z	L1	Z1
15mm	FSPWET15.2	FSPHTET15.2	FSPGET15.2	FSPWET15.1	FSPHTET15.1	FSPGET15.1	83	22	39	17
22mm	FSPWET22.2	FSPHTET22.2	FSPGET22.2	FSPWET22.1	FSPHTET22.1	FSPGET22.1	89	24	44	20
28mm	FSPWET28.2	FSPHTET28.2	FSPGET28.2	FSPWET28.1	FSPHTET28.1	FSPGET28.1	97	24	47	23
35mm	FSPWET35.2	FSPHTET35.2	FSPGET35.2	FSPWET35.1	FSPHTET35.1	FSPGET35.1	110	28	56	28
42mm	FSPWET42.2	FSPHTET42.2	FSPGET42.2	FSPWET42.1	FSPHTET42.1	FSPGET42.1	136	38	70	32
54mm	FSPWET54.2	FSPHTET54.2	FSPGET54.2	FSPWET54.1	FSPHTET54.1	FSPGET54.1	157	41	80	39

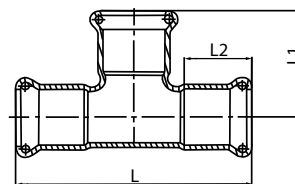

EQUAL TEE

SIZE	EPDM CODE 304	FKM-R CODE 304	HNBR CODE 304	EPDM CODE 316	FKM-R CODE 316	HNBR CODE 316	L	L1	L2
76mm	FSPWET76.2	FSPHTET76.2	FSPGET76.2	FSPWET76.1	FSPHTET76.1	FSPGET76.1	227.5	117.5	60.5
108mm	FSPWET108.2	FSPHTET108.2	FSPGET108.2	FSPWET108.1	FSPHTET108.1	FSPGET108.1	301	157.5	75.5
168mm	-	-	-	FSPWET168.1	FSPHTET168.1	FSPGET168.1	512	242	116

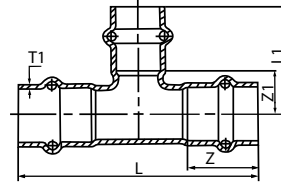

REDUCING TEE

SIZE	EPDM CODE 304	FKM-R CODE 304	HNBR CODE 304	EPDM CODE 316	FKM-R CODE 316	HNBR CODE 316	L	Z	L1	Z1
22 x 22 x 15mm	FSPWRT222215.1	FSPHTRT222215.1	FSPGRT222215.2	FSPWRT222215.1	FSPHTRT222215.1	FSPGRT222215.1	89	24	43	21
28 x 28 x 15mm	FSPWRT282815.1	FSPHTRT282815.1	FSPGRT282815.2	FSPWRT282815.1	FSPHTRT282815.1	FSPGRT282815.1	7	24	55	34
28 x 28 x 22mm	FSPWRT282822.1	FSPHTRT282822.1	FSPGRT282822.2	FSPWRT282822.1	FSPHTRT282822.1	FSPGRT282815.1	7	24	58	36
35 x 35 x 15mm	FSPWRT353515.1	FSPHTRT353515.1	FSPGRT282822.2	FSPWRT353515.1	FSPHTRT353515.1	FSPGRT353515.1	110	28	59	38
35 x 35 x 22mm	FSPWRT353522.1	FSPHTRT353522.1	FSPGRT353522.2	FSPWRT353522.1	FSPHTRT353522.1	FSPGRT353522.1	110	28	62	40
35 x 35 x 28mm	FSPWRT353528.1	FSPHTRT353528.1	FSPGRT353528.2	FSPWRT353528.1	FSPHTRT353528.1	FSPGRT353528.1	110	28	51	27
42 x 42 x 22mm	FSPWRT424222.1	FSPHTRT424222.1	FSPGRT424222.2	FSPWRT424222.1	FSPHTRT424222.1	FSPGRT353528.1	136	38	54	30
42 x 42 x 28mm	FSPWRT424228.1	FSPHTRT424228.1	FSPGRT424228.2	FSPWRT424228.1	FSPHTRT424228.1	FSPGRT424228.1	136	38	55	31
42 x 42 x 35mm	FSPWRT424235.1	FSPHTRT424235.1	FSPGRT424235.2	FSPWRT424235.1	FSPHTRT424235.1	FSPGRT424235.1	136	38	60	32
54 x 54 x 22mm	FSPWRT545422.1	FSPHTRT545422.1	FSPGRT545422.2	FSPWRT545422.1	FSPHTRT545422.1	FSPGRT545422.1	157	41	60	36
54 x 54 x 28mm	FSPWRT545428.1	FSPHTRT545428.1	FSPGRT545428.2	FSPWRT545428.1	FSPHTRT545428.1	FSPGRT545428.1	157	41	61	37
54 x 54 x 35mm	FSPWRT545435.1	FSPHTRT545435.1	FSPGRT545435.2	FSPWRT545435.1	FSPHTRT545435.1	FSPGRT545435.1	157	41	66	38
54 x 54 x 42mm	FSPWRT545442.1	FSPHTRT545442.1	FSPGRT545442.2	FSPWRT545442.1	FSPHTRT545442.1	FSPGRT545442.1	157	41	76	38

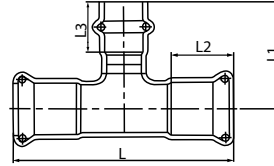

REDUCING TEE

SIZE	EPDM CODE 304	FKM-R CODE 304	HNBR CODE 304	EPDM CODE 316	FKM-R CODE 316	HNBR CODE 316	L	L1	L2	L3
76 x 76 x 22mm	FSPWRT767622.2	FSPHTRT767622.2	FSPGRT767622.2	FSPWRT767622.1	FSPHTRT767622.1	FSPGRT767622.1	227.5	71.5	60	24
76 x 76 x 28mm	FSPWRT767628.2	FSPHTRT767628.2	FSPGRT767628.2	FSPWRT767628.1	FSPHTRT767628.1	FSPGRT767628.1	227.5	71.5	60	24
76 x 76 x 35mm	FSPWRT767635.2	FSPHTRT767635.2	FSPGRT767635.2	FSPWRT767635.1	FSPHTRT767635.1	FSPGRT767635.1	227.5	77	60	28
76 x 76 x 42mm	FSPWRT767642.2	FSPHTRT767642.2	FSPGRT767642.2	FSPWRT767642.1	FSPHTRT767642.1	FSPGRT767642.1	227.5	87.5	60	38
76 x 76 x 54mm	FSPWRT767654.2	FSPHTRT767654.2	FSPGRT767654.2	FSPWRT767654.1	FSPHTRT767654.1	FSPGRT767654.1	227.5	90.5	60	41
108 x 108 x 22mm	FSPWRT10810822.2	FSPHTRT10810822.2	FSPGRT10810822.2	FSPWRT10810822.1	FSPHTRT10810822.1	FSPGRT10810822.1	301	89.5	75	24
108 x 108 x 28mm	FSPWRT10810828.2	FSPHTRT10810828.2	FSPGRT10810828.2	FSPWRT10810828.1	FSPHTRT10810828.1	FSPGRT10810828.1	301	88.5	75	24
108 x 108 x 35mm	FSPWRT10810835.2	FSPHTRT10810835.2	FSPGRT10810835.2	FSPWRT10810835.1	FSPHTRT10810835.1	FSPGRT10810835.1	301	94	75	25
108 x 108 x 42mm	FSPWRT10810842.2	FSPHTRT10810842.2	FSPGRT10810842.2	FSPWRT10810842.1	FSPHTRT10810842.1	FSPGRT10810842.1	301	104.5	75	38
108 x 108 x 54mm	FSPWRT10810854.2	FSPHTRT10810854.2	FSPGRT10810854.2	FSPWRT10810854.1	FSPHTRT10810854.1	FSPGRT10810854.1	301	107.5	75	41

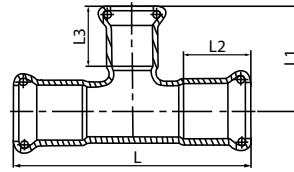

REDUCING TEE

SIZE	EPDM CODE 304	FKM-R CODE 304	HNBR CODE 304	EPDM CODE 316	FKM-R CODE 316	HNBR CODE 316	L	L1	L2	L3
108 x 108 x 76mm	FSPWRT10810876.2	FSPHTRT10810876.2	FSPGRT10810876.2	FSPWRT10810876.1	FSPHTRT10810876.1	FSPGRT10810876.1	301	134.50	75	60.5
168 x 168 x 108mm	-	-	-	FSPWRT168168108.1	FSPHTRT168168108.1	FSPGRT168168108.1	512	242	116	75

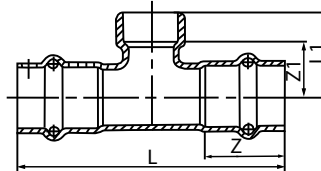

FEMALE CENTRE TEE

SIZE	EPDM CODE 304	FKM-R CODE 304	HNBR CODE 304	EPDM CODE 316	FKM-R CODE 316	HNBR CODE 316	L	Z	L1	Z1
15 x 15 mm x 1/2 FI	FSPWFT151515.2	FSPHTFT151515.2	FSPGFT151515.2	FSPWFT151515.1	FSPHTFT151515.2	FSPGFT151515.1	83	22	36	21
22 x 22 mm x 1/2 FI	FSPWFT222215.2	FSPHTFT222215.2	FSPGFT222215.2	FSPWFT222215.1	FSPHTFT222215.2	FSPGFT222215.1	89	24	40	25
22 x 22 mm x 3/4 FI	FSPWFT222220.2	FSPHTFT222220.2	FSPGFT222220.2	FSPWFT222220.1	FSPHTFT222220.2	FSPGFT222220.1	89	24	42	26
28 x 28mm x 1/2 FI	FSPWFT282815.2	FSPHTFT282815.2	FSPGFT282815.2	FSPWFT282815.1	FSPGFT545415.1	FSPGFT282815.1	97	24	42	27
28 x 28mm x 3/4 FI	FSPWFT282820.2	FSPHTFT282820.2	FSPGFT282820.2	FSPWFT282820.1	FSPHTFT282820.2	FSPGFT282820.1	97	24	44	28
28 x 28mm x 1 FI	FSPWFT282825.2	FSPHTFT282825.2	FSPGFT282820.2	FSPWFT282825.1	FSPHTFT282825.2	FSPGFT282820.1	97	24	48	29
35 x 35mm x 1/2 FI	FSPWFT353515.2	FSPHTFT353515.2	FSPGFT353515.2	FSPWFT353515.1	FSPHTFT353515.2	FSPGFT353515.1	110	28	46	31
35 x 35mm x 1-1/4 FI	FSPWFT353532.2	FSPHTFT353532.2	FSPGFT353520.2	FSPWFT353532.1	FSPHTFT353532.2	FSPGFT353520.1	110	28	56	35
42 x 42mm x 1/2 FI	FSPWFT424215.2	FSPGFT424215.2	FSPGFT353532.2	FSPWFT424215.1	FSPGFT424215.1	FSPGFT353532.1	136	38	60	39
54 x 54mm x 1/2 FI	FSPWFT545415.2	FSPHTFT545415.2	FSPGFT545415.2	FSPWFT545415.1	FSPHTFT545415.2	FSPGFT545415.1	157	41	56	41
54 x 54mm x 3/4 FI	FSPWFT545420.2	FSPHTFT545420.2	FSPGFT545420.2	FSPWFT545420.1	FSPHTFT545420.1	FSPGFT545420.1	157	41	56	41
54 x 54mm x 2 FI	FSPWFT545450.2	FSPHTFT545450.2	FSPGFT545450.2	FSPWFT545450.1	FSPHTFT545450.2	FSPGFT545450.1	157	41	72	46



FEMALE CENTRE TEE

SIZE	EPDM CODE 304	FKM-R CODE 304	HNBR CODE 304	EPDM CODE 316	FKM-R CODE 316	HNBR CODE 316	L	Z	L1	Z1
76 x 76mm x 3/4 FI	FSPWFT767620.2	FSPHTFT767620.2	FSPGFT767620.2	FSPWFT767620.1	FSPHTFT767620.1	FSPGFT767620.1	227.5	60		
76 x 76mm x 2 FI	FSPWFT767650.2	FSPHTFT767650.2	FSPGFT767650.2	FSPWFT767650.1	FSPHTFT767650.1	FSPGFT767650.1	227.5	60		
108 x 108mm x 3/4 FI	FSPWFT10810820.2	FSPHTFT10810820.2	FSPGFT10810820.2	FSPWFT10810820.1	FSPHTFT10810820.1	FSPGFT10810820.1	301	75		
108mm x 108mm x 2 FI	FSPWFT10810850.2	FSPHTFT10810850.2	FSPGFT10810850.2	FSPWFT10810850.1	FSPHTFT10810850.1	FSPGFT10810850.1	301	75		

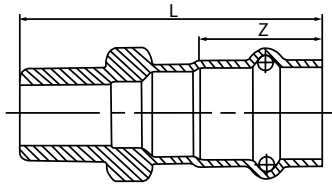

MALE STRAIGHT CONNECTOR

SIZE	EPDM CODE 304	FKM-R CODE 304	HNBR CODE 304	EPDM CODE 316	FKM-R CODE 316	HNBR CODE 316	L	Z
15mm x 1/2 MI	FSPWMSC1515.2	FSPHTMSC1515.2	FSPGMSC1515.2	FSPWMSC1515.1	FSPHTMSC1515.1	FSPGMSC1515.1	55	22
15mm x 3/4 MI	FSPWMSC1520.2	FSPHTMSC1520.2	FSPGMSC1520.2	FSPWMSC1520.1	FSPHTMSC1520.1	FSPGMSC1520.1	58	22
22mm x 1/2 MI	FSPWMSC2215.2	FSPHTMSC2215.2	FSPGMSC1520.2	FSPWMSC2215.1	FSPHTMSC2215.1	FSPGMSC1520.1	56	24
22mm x 3/4 MI	FSPWMSC2220.2	FSPHTMSC2220.2	FSPGMSC2215.2	FSPWMSC2220.1	FSPHTMSC2220.1	FSPGMSC2215.1	58	24
22mm x1 MI	FSPWMSC2225.2	FSPHTMSC2225.2	FSPGMSC2225.2	FSPWMSC2225.1	FSPHTMSC2225.1	FSPGMSC2225.1	60	24
28mm x 3/4 MI	FSPWMSC2820.2	FSPHTMSC2820.2	FSPGMSC2820.2	FSPWMSC2820.1	FSPHTMSC2820.1	FSPGMSC2820.1	60	24
28mm x 1 MI	FSPWMSC2825.2	FSPHTMSC2825.2	FSPGMSC2220.2	FSPWMSC2825.1	FSPHTMSC2825.1	FSPGMSC2220.1	62	24
35mm x 1 MI	FSPWMSC3525.2	FSPHTMSC3525.2	FSPGMSC3525.2	FSPWMSC3525.1	FSPHTMSC3525.1	FSPGMSC3525.1	70	28
35mm x 1-1/4 MI	FSPWMSC3532.2	FSPHTMSC3532.2	FSPGMSC2225.2	FSPWMSC3532.1	FSPHTMSC3532.1	FSPGMSC2225.1	71	28
42mm x 1-1/2 MI	FSPWMSC4240.2	FSPHTMSC4240.2	FSPGMSC2820.2	FSPWMSC4240.1	FSPHTMSC4240.1	FSPGMSC2820.1	82	38
54mm x 2 MI	FSPWMSC5450.2	FSPHTMSC5440.2	FSPGMSC2825.2	FSPWMSC5440.1	FSPHTMSC5440.1	FSPGMSC2825.1	92	42

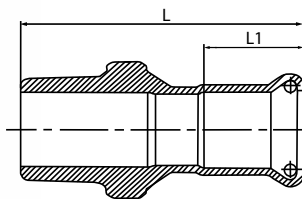

MALE STRAIGHT CONNECTOR

SIZE	EPDM CODE 304	FKM-R CODE 304	HNBR CODE 304	EPDM CODE 316	FKM-R CODE 316	HNBR CODE 316	L	Z
76mm x 2-1/2 MI	FSPWMSC7665.2	FSPHTMSC7665.2	FSPGMSC7665.2	FSPWMSC7665.1	FSPHTMSC7665.1	FSPGMSC7665.1	121	60
76mm x 3 MI	FSPWMSC7680.2	FSPHTMSC7680.2	FSPGMSC7680.2	FSPWMSC7680.1	FSPHTMSC7680.1	FSPGMSC7680.1	124	60
108mm x 4 MI	FSPWMSC108100.2	FSPHTMSC108100.2	FSPGMSC108100.2	FSPWMSC108100.1	FSPHTMSC108100.1	FSPGMSC108100.1	157	65

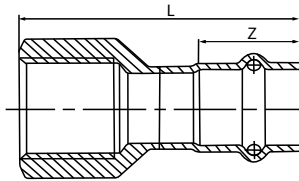

FEMALE STRAIGHT CONNECTOR

SIZE	EPDM CODE 304	FKM-R CODE 304	HNBR CODE 304	EPDM CODE 316	FKM-R CODE 316	HNBR CODE 316	L	Z
15mm x 1/2 FI	FSPWFSC1515.2	FSPHTFSC1515.2	FSPGFSC1515.2	FSPWFSC1515.1	FSPWFSC1515.1	FSPGFSC1515.1	51	22
15mm x 3/4 FI	FSPWFSC1520.2	FSPHTFSC1520.2	FSPGFSC1520.2	FSPWFSC1520.1	FSPHTFSC1520.1	FSPGFSC1520.1	52	22
22mm x 1/2 FI	FSPWFSC2215.2	FSPHTFSC2215.2	FSPGFSC1520.2	FSPWFSC2215.1	FSPWFSC2215.1	FSPGFSC1520.1	52	24
22mm x 3/4 FI	FSPWFSC2220.2	FSPHTFSC2220.2	FSPGFSC2215.2	FSPWFSC2220.1	FSPWFSC2220.1	FSPGFSC2215.1	54	24
22mm x 1 FI	FSPWFSC2225.2	FSPHTFSC2225.2	FSPGFSC2225.2	FSPWFSC2225.1	FSPHTFSC2225.1	FSPGFSC2225.1	59	24
28mm x 3/4 FI	FSPWFSC2820.2	FSPHTFSC2820.2	FSPGFSC2820.2	FSPWFSC2820.1	FSPHTFSC2820.1	FSPGFSC2820.1	54	24
28mm x 1 FI	FSPWFSC2825.2	FSPHTFSC2825.2	FSPGFSC2220.2	FSPWFSC2825.1	FSPWFSC2825.1	FSPGFSC2220.1	59	24
35mm x 1-1/4 FI	FSPWFSC3532.2	FSPHTFSC3532.2	FSPGFSC2225.2	FSPWFSC3532.1	FSPWFSC3532.1	FSPGFSC2225.1	68	28
42mm x 1-1/2 FI	FSPWFSC4240.2	FSPHTFSC4240.2	FSPGFSC2820.2	FSPWFSC4240.1	FSPWFSC4240.1	FSPGFSC2820.1	80	38
54mm x 2 FI	FSPWFSC5450.2	FSPHTFSC5450.2	FSPGFSC2825.2	FSPWFSC5450.1	FSPWFSC5450.1	FSPGFSC2825.1	88	41

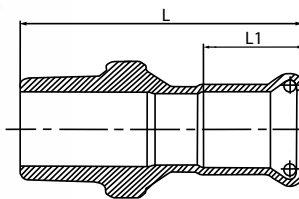

FEMALE STRAIGHT CONNECTOR

SIZE	EPDM CODE 304	FKM-R CODE 304	HNBR CODE 304	EPDM CODE 316	FKM-R CODE 316	HNBR CODE 316	L	Z
76mm X 2-1/2 FI	FSPWFSC7665.2	FSPHTFSC7665.2	FSPGMSC7665.2	FSPWFSC7665.2	FSPGFSC7680.1	FSPGMSC7665.1	118	60
76mm X 3 FI	FSPWFSC7680.2	FSPHTFSC7680.2	FSPGMSC7680.2	FSPWFSC7680.2	FSPHTFSC7680.2	FSPGMSC7680.1	124	60
108mm X 4 FI	FSPWFSC108100.2	FSPHTFSC108100.2	FSPGMSC108100.2	FSPWFSC108100.2	FSPHTFSC108100.2	FSPGMSC108100.1	147	65

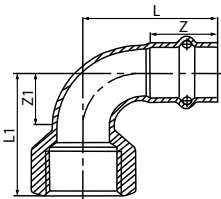

FEMALE ELBOW

SIZE	EPDM CODE 304	FKM-R CODE 304	HNBR CODE 304	EPDM CODE 316	FKM-R CODE 316	HNBR CODE 316	L	Z	L1	Z1
15mm x 1/2 FI	FSPWFE1515.2	FSPHTE1515.2	FSPGFE1515.2	FSPWFE1515.1	FSPHTE1515.1	FSPGFE1515.1	46	22	47	19
22mm x 3/4 FI	FSPWFE2220.2	FSPHTE2220.2	FSPGFE2220.2	FSPWFE2220.1	FSPHTE2220.1	FSPGFE2220.1	55	24	57	27
28mm x 1 FI	FSPWFE2825.2	FSPHTE2825.2	FSPGFE2825.2	FSPWFE2825.1	FSPHTE2825.1	FSPGFE2825.1	66	24	69	36
35mm x 1-1/4 FI	FSPWFE3532.2	FSPHTE3532.2	FSPGFE3532.2	FSPWFE3532.1	FSPHTE3532.1	FSPGFE3532.1	79	28	82	45
42mm x 1-1/2 FI	FSPWFE4240.2	FSPHTE4240.2	FSPGFE4240.2	FSPWFE4240.1	FSPHTE4240.1	FSPGFE4240.1	101	38	90	53
54mm x 2 FI	FSPWFE5450.2	FSPHTE5450.2	FSPGFE5450.2	FSPWFE5450.1	FSPHTE5450.1	FSPGFE5450.1	120	41	111	67

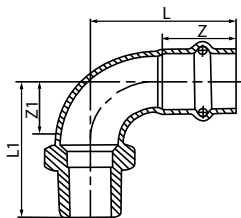

MALE ELBOW

SIZE	EPDM CODE 304	FKM-R CODE 304	HNBR CODE 304	EPDM CODE 316	FKM-R CODE 316	HNBR CODE 316	L	Z	L1	Z1
15mm x 1/2 MI	FSPWME1515.2	FSPHTE1515.2	FSPGME1515.2	FSPWME1515.1	FSPHTE1515.1	FSPGME1515.1	46	22	47	19
22mm x 3/4 MI	FSPWME2220.2	FSPHTE2220.2	FSPGME2220.2	FSPWME2220.1	FSPHTE2220.1	FSPGME2220.1	55	24	57	27
28mm x 1 MI	FSPWME2825.2	FSPHTE2825.2	FSPGME2825.2	FSPWME2825.1	FSPHTE2825.1	FSPGME2825.1	66	24	69	36
35mm x 1-1/4 MI	FSPWME3532.2	FSPHTE3532.2	FSPGME3532.2	FSPWME3532.1	FSPHTE3532.1	FSPGME3532.1	79	28	82	45
42mm x 1-1/2 MI	FSPWME4240.2	FSPHTE4240.2	FSPGME4240.2	FSPWME4240.1	FSPHTE4240.1	FSPGME4240.1	101	38	90	53
54mm x 2 MI	FSPWME5450.2	FSPHTE5450.2	FSPGME5450.2	FSPWME5450.1	FSPHTE5450.1	FSPGME5450.1	120	41	111	67

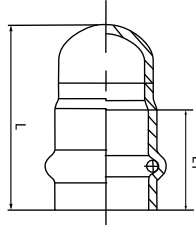

END CAP

SIZE	EPDM CODE 304	FKM-R CODE 304	HNBR CODE 304	EPDM CODE 316	FKM-R CODE 316	HNBR CODE 316	L	L1
15mm	FSPWEC15.2	FSPHTEC15.2	FSPGEC15.2	FSPWEC15.1	FSPHTEC15.1	FSPGEC15.1	32	22
22mm	FSPWEC22.2	FSPHTEC22.2	FSPGEC22.2	FSPWEC22.1	FSPHTEC22.1	FSPGEC22.1	34	24
28mm	FSPWEC28.2	FSPHTEC28.2	FSPGEC28.2	FSPWEC28.1	FSPHTEC28.1	FSPGEC28.1	35	24
35mm	FSPWEC35.2	FSPHTEC35.2	FSPGEC35.2	FSPWEC35.1	FSPHTEC35.1	FSPGEC35.1	40	28
42mm	FSPWEC42.2	FSPHTEC42.2	FSPGEC42.2	FSPWEC42.1	FSPHTEC42.1	FSPGEC42.1	52	38
54mm	FSPWEC54.2	FSPHTEC54.2	FSPGEC54.2	FSPWEC54.1	FSPHTEC54.1	FSPGEC54.1	56	41
76mm	FSPWEC76.2	FSPHTEC76.2	FSPGEC76.2	FSPWEC76.1	FSPHTEC76.1	FSPGEC76.1	105.5	60
108mm	FSPWEC108.2	FSPHTEC108.2	FSPGEC108.2	FSPWEC108.1	FSPHTEC108.1	FSPGEC108.1	137	75

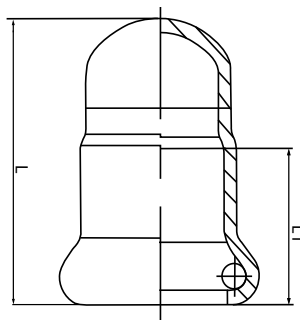

END CAP

SIZE	EPDM CODE 304	FKM-R CODE 304	HNBR CODE 304	EPDM CODE 316	FKM-R CODE 316	HNBR CODE 316	L	L1
76mm	FSPWEC76.2	FSPHTEC76.2	FSPGEC76.2	FSPWEC76.1	FSPHTEC76.1	FSPGEC76.1	105.5	60
108mm	FSPWEC108.2	FSPHTEC108.2	FSPGEC108.2	FSPWEC108.1	FSPHTEC108.1	FSPGEC108.1	137	75

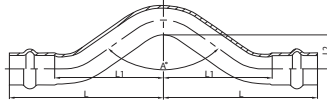

FULL CROSS OVER

SIZE	EPDM CODE 304	FKM-R CODE 304	HNBR CODE 304	EPDM CODE 316	FKM-R CODE 316	HNBR CODE 316	L	L1	L2	A
15mm	FSPWFC015.2	FSPHTFC015.2	FSPGC015.2	FSPWFC015.1	FSPHTFC015.1	FSPGC015.1	75	53	21	100°
22mm	FSPWFC022.2	FSPHTFC022.2	FSPGC022.2	FSPWFC022.1	FSPHTFC022.1	FSPGC022.1	95	65	26	100°
28mm	FSPWFC028.2	FSPHTFC028.2	FSPGC028.2	FSPWFC028.1	FSPHTFC028.1	FSPGC028.1	105	85	28	100°

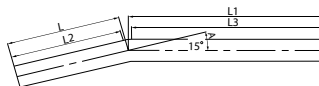

15° PIPE BRIDGE

SIZE	CODE 304	CODE 316	A	L	L1	L2	L3
15mm X 15D	FSPW15TBP15.2	FSPW15TBP15.1	15	66	125	62	122
22mm X 15D	FSPW15TBP22.2	FSPW15TBP22.1	15	75	150	71	146
28mm X 15D	FSPW15TBP28.2	FSPW15TBP28.1	15	85	200	79.5	194.5
35mm X 15D	FSPW15TBP35.2	FSPW15TBP35.1	15	92	225	85	218
42mm X 15D	FSPW15TBP42.2	FSPW15TBP42.1	15	113	250	105	242
54mm X 15D	FSPW15TBP54.2	FSPW15TBP54.1	15	131	300	120.5	289.5
76mm X 15D	FSPW15TBP76.2	FSPW15TBP76.1	15	162	350	147	335
108mm X 15D	FSPW15TBP108.2	FSPW15TBP108.1	15	231	350	210	329

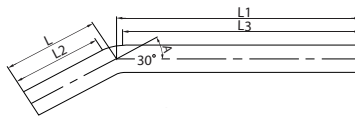

30° PIPE BRIDGE

SIZE	CODE 304	CODE 316	A	L	L1	L2	L3
15mm X 30D	FSPW30TBP15.2	FSPW30TBP15.1	30	66	125	60	119
22mm X 30D	FSPW30TBP22.2	FSPW30TBP22.1	30	75	150	66	141
28mm X 30D	FSPW30TBP28.2	FSPW30TBP28.1	30	85	200	74	189
35mm X 30D	FSPW30TBP35.2	FSPW30TBP35.1	30	92	225	78	211
42mm X 30D	FSPW30TBP42.2	FSPW30TBP42.1	30	113	250	96	233
54mm X 30D	FSPW30TBP54.2	FSPW30TBP54.1	30	131	300	109	278
76mm X 30D	FSPW30TBP76.2	FSPW30TBP76.1	30	162	350	131.5	319.5
108mm X 30D	FSPW30TBP108.2	FSPW30TBP108.1	30	231	350	187.5	306.5

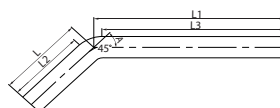

45° PIPE BRIDGE

SIZE	CODE 304	CODE 316	A	L	L1	L2	L3
15mm X 45D	FSPW45TBP15.2	FSPW45TBP15.1	45	66	125	57	116
22mm X 45D	FSPW45TBP22.2	FSPW45TBP22.1	45	75	150	61.5	136.5
28mm X 45D	FSPW45TBP28.2	FSPW45TBP28.1	45	85	200	67.5	182.5
35mm X 45D	FSPW45TBP35.2	FSPW45TBP35.1	45	92	225	70.5	203.5
42mm X 45D	FSPW45TBP42.2	FSPW45TBP42.1	45	113	250	87	224
54mm X 45D	FSPW45TBP54.2	FSPW45TBP54.1	45	131	300	97.5	266.5
76mm X 45D	FSPW45TBP76.2	FSPW45TBP76.1	45	162	350	115	303
108mm X 45D	FSPW45TBP108.2	FSPW45TBP108.1	45	231	350	164	283

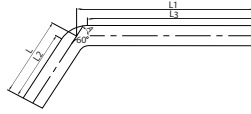

45° PIPE BRIDGE

SIZE	CODE 304	CODE 316	A	L	L1	L2	L3
15mm X 60D	FSPW60TBP15.2	FSPW60TBP15.1	60	66	125	53	112
22mm X 60D	FSPW60TBP22.2	FSPW60TBP22.1	60	75	150	56	131
28mm X 60D	FSPW60TBP28.2	FSPW60TBP28.1	60	85	200	61	176
35mm X 60D	FSPW60TBP35.2	FSPW60TBP35.1	60	82	225	62	195
42mm X 60D	FSPW60TBP42.2	FSPW60TBP42.1	60	113	250	77	214
54mm X 60D	FSPW60TBP54.2	FSPW60TBP54.1	60	131	300	84	253
76mm X 60D	FSPW60TBP76.2	FSPW60TBP76.1	60	162	350	96	284
108mm X 60D	FSPW60TBP108.2	FSPW60TBP108.1	60	231	350	137.5	256.5

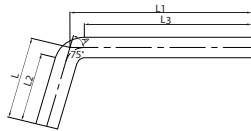

75° PIPE BRIDGE

SIZE	CODE 304	CODE 316	A	L	L1	L2	L3
15mm X 75D	FSPW75TBP15.2	FSPW75TBP15.1	75	66	125	49	108
22mm X 75D	FSPW75TBP22.2	FSPW75TBP22.1	75	75	150	50	125
28mm X 75D	FSPW75TBP28.2	FSPW75TBP28.1	75	85	200	53	168
35mm X 75D	FSPW75TBP35.2	FSPW75TBP35.1	75	92	225	52	185
42mm X 75D	FSPW75TBP42.2	FSPW75TBP42.1	75	113	250	65	202
54mm X 75D	FSPW75TBP54.2	FSPW75TBP54.1	75	131	300	69	238
76mm X 75D	FSPW75TBP76.2	FSPW75TBP76.1	75	162	350	74.5	262.5
108mm X 75D	FSPW75TBP108.2	FSPW75TBP108.1	75	231	350	107	226

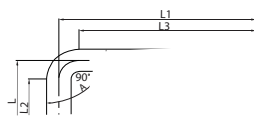

90° PIPE BRIDGE

SIZE	CODE 304	CODE 316	A	L	L1	L2	L3
15mm X 90D	FSPW90TBP15.2	FSPW90TBP15.1	90	62	125	39.5	102.5
22mm X 90D	FSPW90TBP22.2	FSPW90TBP22.1	90	73	150	40	117
28mm X 90D	FSPW90TBP28.2	FSPW90TBP28.1	90	85	200	43	158
35mm X 90D	FSPW90TBP35.2	FSPW90TBP35.1	90	92	225	39.5	172.5
42mm X 90D	FSPW90TBP42.2	FSPW90TBP42.1	90	113	250	50	187
54mm X 90D	FSPW90TBP54.2	FSPW90TBP54.1	90	131	300	50	219
76mm X 90D	FSPW90TBP76.2	FSPW90TBP76.1	90	162	350	48	236
108mm X 90D	FSPW90TBP108.2	FSPW90TBP108.1	90	231	350	69	188

6.2 O-RING SEALS



FORZA STAINLESS PRESS 316L

	HIGH PRESSURE	STANDARD PRESSURE
	DIMENSION / HIGH PRESSURE	DIMENSION / STANDARD PRESSURE
EPDM BLACK 'O' RING	DN15-22MM / PN40	DN15-22MM / PN40
	DN28-35MM / PN40	DN28-35MM / PN25
	DN42-108MM / PN40	DN42-108MM / PN16
		DN168MM PN16
HNBR YELLOW 'O' RING	DN15-108MM / PN5	DN15-108MM / PN5
	DN15-22 / PN40	DN15-22MM / PN40
FKM RED 'O' RING	DN28-35MM / PN40	DN28-35MM / PN25
	DN42-108MM / PN40	DN42-108MM / PN16

FORZA STAINLESS PRESS 304L

	STANDARD PRESSURE
	DIMENSION / STANDARD PRESSURE
EPDM BLACK 'O' RING	DN15-22MM / PN40
	DN28-35MM / PN25
	DN42-108MM / PN16
	DN140-168MM PN16
HNBR YELLOW 'O' RING	DN15-108MM / PN5
	DN15-22MM / PN40
FKM RED 'O' RING	DN28-35MM / PN25
	DN42-108MM / PN16

Note: Only 316L pipe and fittings are rated to 4000 KPA. This rating is only achieved when using the purpose designed High Pressure jaws and tool.

O-RING SELECTION CHART

MEDIUM APPLICATIONS	WATER EPDM	HT FKM	GAS HNBR
POTABLE WATER	●	●	
NON-POTABLE WATER	●	●	
SOLAR SYSTEM		●	
FLOW AND RETURN INDUSTRIAL FLUIDS	●	●	
FUEL AND NATURAL GAS			●
SPECIALIST AND LIQUID GAS	●	●	●
FIRE SPRINKLER	●		
FUEL OIL/HYDROCARBON		●	
COMPRESSED AIR		●	

INDUSTRY APPLICATIONS

INDUSTRY APPLICATIONS	WATER EPDM	HT FKM	GAS HNBR
MANUFACTURING	●	●	
SHIP BUILDING AND RAIL	●	●	●
INDUSTRY GENERAL AND HEAVY	●	●	●
AUTOMOTIVE	●	●	
MEDICAL	●	●	●
CHEMICAL	●	●	●
CO-GENERATION ENERGY	●	●	
MINING	●	●	●
FOOD AND BEVERAGE	●	●	●
PULP AND PAPER	●	●	

EPDM - Ethylene Propylene Diene Monomer
 FKM - Fluorocarbon Rubber
 HNBR - Hydrogenated Nitrile Butadiene Rubber

6.3 BARREL UNION

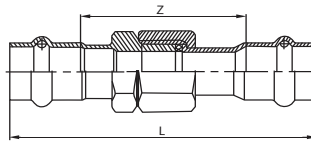

BARREL UNION

SIZE	EPDM CODE 304	FKM-R CODE 304	HNBR CODE 304	EPDM CODE 316	FKM-R CODE 316	HNBR CODE 316	L	Z
15mm	FSPWBU1515.2	FSPHTBU1515.2	FSPGBU1515.2	FSPWBU1515.1	FSPHTBU1515.2	FSPGBU1515.1	100	56
22mm	FSPWBU2222.2	FSPHTBU2222.2	FSPGBU2222.2	FSPWBU2222.1	FSPHTBU2222.2	FSPGBU2222.1	108	60
28mm	FSPWBU2828.2	FSPHTBU2828.2	FSPGBU2828.2	FSPWBU2828.1	FSPHTBU2828.2	FSPGBU2828.1	120	72
35mm	FSPWBU3535.2	FSPHTBU3535.2	FSPGBU3535.2	FSPWBU3535.1	FSPHTBU3535.2	FSPGBU3535.1	126	70
42mm	FSPWBU4242.2	FSPHTBU4242.2	FSPGBU4242.2	FSPWBU4242.1	FSPHTBU4242.2	FSPGBU4242.1	152	76
54mm	FSPWBU5454.2	FSPHTBU5454.2	FSPGBU5454.2	FSPWBU5454.1	FSPHTBU5454.2	FSPGBU5454.1	166	84

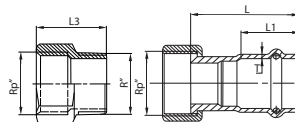

FEMALE BARREL UNION

SIZE	EPDM CODE 304	FKM-R CODE 304	HNBR CODE 304	EPDM CODE 316	FKM-R CODE 316	HNBR CODE 316	L	L1	L2
15mm x 1/2 FI	FSPWFBU1515.2	FSPHTFBU1515.2	FSPGFBU1515.2	FSPWFBU1515.1	FSPHTFBU1515.1	FSPGFBU1515.1	48	22	31
15mm x 3/4 FI	FSPWFBU1520.2	FSPHTFBU1520.2	FSPGFBU1520.2	FSPWFBU1520.1	FSPHTFBU1520.1	FSPGFBU1520.1	48	22	34.5
22mm x 3/4 FI	FSPWFBU2220.2	FSPHTFBU2220.2	FSPGFBU1520.2	FSPWFBU2220.1	FSPHTFBU2220.1	FSPGFBU1520.1	51	24	34.5
22mm x 1 FI	FSPWFBU2225.2	FSPHTFBU2225.2	FSPGFBU2225.2	FSPWFBU2225.1	FSPHTFBU2225.1	FSPGFBU2225.1	51	24	39
28mm x 3/4 FI	FSPWFBU2820.2	FSPHTFBU2820.2	FSPGFBU2820.2	FSPWFBU2820.1	FSPHTFBU2820.1	FSPGFBU2820.1	51	24	34.5
28mm x 1 FI	FSPWFBU2825.2	FSPHTFBU2825.2	FSPGFBU2220.2	FSPWFBU2825.1	FSPHTFBU2825.1	FSPGFBU2220.1	51	24	39
35mm x 1-1/4 FI	FSPWFBU3532.2	FSPHTFBU3532.2	FSPGFBU2225.2	FSPWFBU3532.1	FSPHTFBU3532.1	FSPGFBU2225.1	56	28	42
42mm x 2 FI	FSPWFBU4240.2	FSPHTFBU4240.2	FSPGFBU2820.2	FSPWFBU4240.1	FSPHTFBU4240.1	FSPGFBU2820.1	72	38	47.5
54mm x 2 FI	FSPWFBU5450.2	FSPHTFBU5450.2	FSPGFBU2825.2	FSPWFBU5450.1	FSPHTFBU5450.1	FSPGFBU2825.1	78	41	52.5

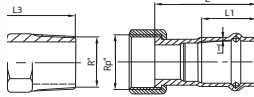

MALE BARREL UNION

SIZE	EPDM CODE 304	FKM-R CODE 304	HNBR CODE 304	EPDM CODE 316	FKM-R CODE 316	HNBR CODE 316	L	L1	L2
15mm x 1/2 MI	FSPWMBU1515.2	FSPHTFBU1515.2	FSPGMBU1515.2	FSPWMBU1515.1	FSPHTMBU1515.1	FSPGMBU1515.1	48	22	42
15mm x 3/4 MI	FSPWMBU1520.2	FSPHTMBU1520.2	FSPGMBU1520.2	FSPWMBU1520.1	FSPHTMBU1520.1	FSPGMBU1520.1	48	22	46
22mm x 3/4 MI	FSPWMBU2220.2	FSPHTFBU2220.2	FSPGMBU1520.2	FSPWMBU2220.1	FSPHTMBU2220.1	FSPGMBU1520.1	51	24	46
28mm x 1 MI	FSPWMBU2825.2	FSPHTFBU2825.2	FSPGMBU2220.2	FSPWMBU2825.1	FSPHTMBU2825.1	FSPGMBU2220.1	51	24	53
35mm x 1-1/4 MI	FSPWMBU3532.2	FSPHTFBU3532.2	FSPGMBU2825.2	FSPWMBU3532.1	FSPHTMBU3532.1	FSPGMBU2825.1	56	28	61
42mm x 2 MI	FSPWMBU4240.2	FSPHTFBU4240.2	FSPGMBU3532.2	FSPWMBU4240.1	FSPHTMBU4240.1	FSPGMBU3532.1	72	38	64
54mm x 2 MI	FSPWMBU5450.2	FSPHTFBU5450.2	FSPGMBU4240.2	FSPWMBU5450.1	FSPHTMBU5450.1	FSPGMBU4240.1	78	41	76

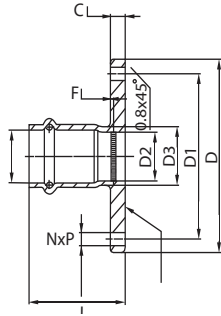

FLANGE ADAPTOR TABLE 'E'

FLANGE ADAPTOR TABLE 'E'

SIZE	EPDM CODE 304	FKM-R CODE 304	HNBR CODE 304	EPDM CODE 316	FKM-R CODE 316	HNBR CODE 316	L	D	D1	D2	D3	C	F	NxP	B	R
15mm	FSPWF4A15.2	FSPHTF4A15.2	FSPGF4A15.2	FSPWF4A15.1	FSPHTF4A15.1	FSPGF4A15.1	45	95	64	14.0	17.0	7.0	3.0	4 x 14	M12	2.0
22mm	FSPWF4A22.2	FSPHTF4A22.2	FSPGF4A22.2	FSPWF4A22.1	FSPHTF4A22.1	FSPGF4A22.1	48	100	73	21.0	24.0	7.0	3.0	4 x 14	M12	2.0
28mm	FSPWF4A28.2	FSPHTF4A28.2	FSPGF4A28.2	FSPWF4A28.1	FSPHTF4A28.1	FSPGF4A28.1	52	115	83	25.0	28.0	8.0	3.0	4 x 14	M12	2.0
35mm	FSPWF4A35.2	FSPHTF4A35.2	FSPGF4A35.2	FSPWF4A35.1	FSPHTF4A35.1	FSPGF4A35.1	59	120	87	32.0	35.0	9.5	3.0	4 x 14	M12	2.0
42mm	FSPWF4A42.2	FSPHTF4A42.2	FSPGF4A42.2	FSPWF4A42.1	FSPHTF4A42.1	FSPGF4A42.1	78	135	98	39.0	42.0	9.5	3.0	4 x 14	M12	2.0
54mm	FSPWF4A54.2	FSPHTF4A54.2	FSPGF4A54.2	FSPWF4A54.1	FSPHTF4A54.1	FSPGF4A54.1	99	150	114	51.0	54.0	10.0	3.0	4 x 18	M16	2.0
76mm	FSPWF4A76.2	FSPHTF4A76.2	FSPGF4A76.2	FSPWF4A76.1	FSPHTF4A76.1	FSPGF4A76.1	90	185	146	72.1	76.1	11.0	3.0	4 x 18	M16	2.5
108mm	FSPWF4A108.2	FSPHTF4A108.2	FSPGF8A108.2	FSPWF4A108.1	FSPHTF4A108.1	FSPGF8A108.1	116	215	178	104	108	13.0	3.0	8 x 18	M16	2.5

FLANGE STEM ADAPTOR TABLE 'E'

SIZE	CODE 304	CODE 316	L	D	D1	D2	D3	C	F	NxP	B	R
15mm	FSPWF4S15.2	FSPWF4S15.1	248	95	64	14.0	17.0	7.0	3.0	4 x 14	M12	2.0
22mm	FSPWF4S22.2	FSPWF4S22.1	248	100	73	21.0	24.0	7.0	3.0	4 x 14	M12	2.0
28mm	FSPWF4S28.2	FSPWF4S28.1	248	115	83	25.0	28.0	8.0	3.0	4 x 14	M12	2.0
35mm	FSPWF4S35.2	FSPWF4S35.1	251	120	87	32.0	35.0	9.5	3.0	4 x 14	M12	2.0
42mm	FSPWF4S42.2	FSPWF4S42.1	258	135	98	39.0	42.0	9.5	3.0	4 x 14	M12	2.0
54mm	FSPWF4S54.2	FSPWF4S54.1	260	150	114	51.0	54.0	10.0	3.0	4 x 18	M16	2.0
76mm	FSPWF4S76.2	FSPWF4S76.1	259	185	146	72.1	76.1	11.0	3.0	4 x 18	M16	2.5
108mm	FSPWF4S108.2	FSPWF4S108.1	254	215	178	104	108	13.0	3.0	8 x 18	M16	2.5

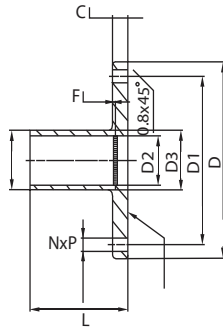

FLANGE ADAPTOR TABLE 'E'

SIZE	EPDM CODE 304	FKM-R CODE 304	HNBR CODE 304	HNBR CODE 316	EPDM CODE 316	FKM-R CODE 316	HNBR CODE 316	L	D	D1	D2	D3	C	F	NxP	B	R
76mm	FSPWF4A76.2	FSPHTF4A76.2	FSPGF4A76.2	FSPGF4A76.1	FSPWF4A76.1	FSPHTF4A76.1	FSPGF4A76.1	90	185	146	72.1	76.1	11.0	3.0	4 x 18	M16	2.5
108mm	FSPWF4A108.2	FSPHTF4A108.2	FSPGF8A108.2	FSPGF8A108.1	FSPWF4A108.1	FSPHTF4A108.1	FSPGF8A108.1	116	215	178	104	108	13.0	3.0	8 x 18	M16	2.5

FLANGE ADAPTOR TABLE 'E'

FREQUENTLY ASKED QUESTIONS

- Q. Can you rotate a Forza Stainless Steel Press fitting once installed? A. No, once pressed, they cannot be rotated.
- Q. Can Forza Stainless Steel Press be dismantled and reused? A. No, this is a permanent installation.
- Q. What is the recommended space between fittings? A. Please see 'distance between fittings' section on page 14.
- Q. Can Forza Stainless Steel Press handle suction or negative pressure? A. Yes, Forza Stainless Steel Press fittings are tested at a vacuum test pressure of - 85 kPa at ambient temperature.
- Q. Can Forza Press Stainless Steel fittings be installed on pipes where the mains line won't shut off? A. Yes, the fitting can be used in wet conditions and after pressing will provide a watertight joint.
- Q. Do I need to lubricate the O-ring? A. No, the O-ring is pre-lubricated. Additional lubricants could impact on the life of the O-ring and void the warranty. If the O-ring appears dry a small amount of water can be used to lubricate it.
- Q. Is Forza Press Stainless Steel certified for use in potable water systems? A. Yes Forza Press Stainless Steel is Watermark certified.
- Q. What stainless steel tubes can Forza Press Stainless Steel be used with? A. Forza Press Stainless Steel fittings can be used with all stainless steel tubes that comply with AS 5200.053 Series 2.
- Q. What other materials can be connected with stainless steel system? A. Stainless steel, copper and copper alloys can be combined without the risk of corrosion. Please note carbon steel should not be directly connected to stainless steel as this will cause corrosion. A spacer connector of brass material should be used to separate the two dissimilar materials by at least 50mm. Flow of water should be in the direction from carbon steel to stainless steel and not vice versa.
- Q. What is the warranty on Forza Press Stainless Steel fittings? A. The product has a 25 year limited warranty.
- Q. Are there any storage issues? A. Fittings should be stored in a cool dry place in their original packaging. This protects the fittings from contamination, damage and dirt and conserves the lubrication on the O-rings prior to installation
- Q. If a fitting leaks on installation, can you weld the fitting rather than cutting out the joint and having to replace missing tube? A. No, if a fitting that has been pressed is leaking, the fitting must be cut out and replaced. You should not attempt to weld the fitting as you will melt the O-ring destroying the sealing element.
- Q. Are there concerns with internal corrosion in stainless steel pipework? A. Within a stainless steel pipework system a passive layer, mostly formed from chromic oxide is created upon contact with oxygen or oxygenated water (i.e. drinking water). This layer restricts corrosion from occurring and provides high levels of hygiene, durability and water quality.
- Q. Are there any concerns with external corrosion in stainless steel pipework? A. External corrosion of stainless steel pipework is likely to occur when exposed to high levels of chloride. Forza Press Stainless Steel fittings should not be installed in this situation. However, if there are parts of the system where this is unavoidable, appropriate precautions must be taken to minimise the risk.
- Q. Can you press a fitting more than once? A. No, Forza Press Stainless Steel fittings can be pressed only once.



FORZA GLOBAL PTY LTD

**HEAD OFFICE
QUEENSLAND**

1/73 WENTWORTH PLACE
BANYO QLD 4014
T: (07) 3266 1001 F: (03) 9923 6324

VICTORIA

2/8 BARCLAY ROAD
DERRIMUT VIC 3030
T: (03) 8348 5704 F: (03) 9923 6324

ABN 42 161 669 549 ACN 161 669 549

WWW.FORZAGLOBAL.COM.AU

A dark grey gradient bar at the bottom of the page, transitioning from a lighter grey on the left to a darker grey on the right.