



FORZA
COPPER V PRESS

TM

SPECIFICATIONS &
INSTALLATION GUIDE
ANOTHER QUALITY
PRODUCT BY
FORZA GLOBAL

FORZA COPPER 'V' PRESS THE FORCE IN COPPER PRESS



Forza Global in partnership with one of the world's largest and most respected copper manufacturers has spent the last 2 years developing a Copper 'V' Press fitting system with a 25 Year Warranty that will prove to be the most reliable and economical system in the Australian and New Zealand markets.

Forza Copper 'V' Press is available in sizes DN15 through to DN100 with a range of over 170 different fittings for Water application, over 160 different fittings for Gas application and a full range of fittings for High Temperature Application.

WHY INSTALL FORZA COPPER 'V' PRESS?

- Forza 'V' Press Copper fittings are suitable to be used on all Hard Drawn, Hard Drawn BQ and Annealed Type A and B Copper Tube that complies with AS1432
- No welding required, eliminating the need for Hot Works permit
- All fittings work with Kempress, Viega and B- Press tooling
- Fittings profile are 'V' which is the most preferred profile by installers
- Largest overall range in the market across Water, Gas and High Temperature fittings
- The double press of each connection both in front and behind the O ring seal
- All fittings and packaging are colour coded to avoid any mistakes upon installation
- Fittings are fitted with Leak detection O rings to ensure that installers can't miss an unpressed fitting
- Fittings allow for cylindrical pipe insertion to avoid damaging the O rings during installation



TECH DATA AND SPECIFICATION

FITTINGS APPLICATION

The Forza Copper 'V' Press range exceeds over 340 fittings across Water, Gas and High Temperature. The leak detection O ring feature assures that leakage of liquids and gases will occur if the fitting is not pressed correctly. All fittings DN15-DN50 have leak detection O rings to suit specific installations and cannot be interchanged, all packaging and fittings are colour coded for different types of installation. All fittings DN65-DN100 have O rings and a Stainless-Steel grip ring which reinforces the joint when pressed. All fittings can be installed with Hard Drawn, Hard Drawn BQ and Annealed Type A and B Copper tube that complies with AS1432.

FITTING PRESS PROFILE

The 'V' profile design used by Forza is the most preferred profile in the market place. Because the fitting is double pressed it gives installers confidence that the connection will be long lasting as the installer can see that the fitting is pressed both in front and behind the O ring. The cylindrical pipe insertion when using 'V' profile fittings gives installers the peace of mind that there won't be any damage to the O ring seal.

APPROVED APPLICATIONS AND OPERATING PARAMETERS

- Potable Water
- Chilled Water
- Hydronic Heating
- Vacuum
- Non-Medical Gases
- Fire Services
- Low Pressure Steam

FITTING	O-RING MATERIAL	PRESSURE RATING KPA	TEMP. °C
WATER	EPDM	1600	120
GAS	HNBR	1600	100
HIGH TEMPERATURE	FKM	1600	200

CERTIFICATION & TESTING: FITTINGS

Forza Copper 'V' Press has a Watermark license/certificate and is compliant to AS3688:2016 Water Supply and gas systems- Metallic fittings and end connectors and AS4020.

Below is a list of tests performed to comply with watermark requirements:

WATER FITTINGS

- Leak tightness under internal pressure
- Strength of joint assembly (pressure cycling test)
- Resistance to pull-out of assembled joints
- Leaktightness under internal pressure while subjected to bending
- Method for determining compatibility of water fittings with pipe
- Vacuum test for leaktightness of joints with tube under vacuum
- Resistance of press fitting joints and tubes to vibration

GAS FITTINGS

- Resistance to pull-out of assembled joints
- Leaktightness under internal pressure whilst subjected to bending
- Vacuum test for leaktightness of joints with tube under vacuum
- Leaktightness under internal pneumatic pressure
- Resistance of gas press fittings to temperature cycling
- Resistance of press fitting joints and tubes to vibration
- Resistance of gas press fittings to high temperature





CERTIFICATE OF CONFORMITY

ApprovalMark International hereby grants:

Forza Global Pty Ltd

2/8 Barclay Road
Derrimut, VIC 3030
AUSTRALIA

WaterMark Certificate of Conformity – WMCS 2016

Evaluated to:

AS/NZS 3688:2016 – Water supply and gas systems – Metallic fittings and end connectors

The WaterMark licensee shall comply with all the terms and conditions as stipulated by the governance of the operating rules of WaterMark and shall comply with standard requirement at all times including when standard is amended. The WaterMark license only covers the product which is identified in the product schedule.

This certificate is issued by a JAS-ANZ accredited certification body. The ABCB and JAS-ANZ do not in any way warrant, guarantee or represent that the product the subject of this Certificate conforms to the WaterMark Certification Scheme Rules, nor accepts any liability arising out of the use of the product. The ABCB disclaims to the extent permitted by law, all liability (including negligence) for claims of losses, expenses, damages, and costs arising as a result of the use of the product(s) referred to in this certificate.

* This certificate may only be reproduced in its entirety.

Certificate No. WM 74718

Issued: 5th April 2022

Originally Certified: 13th April 2017

Expires: 13th April 2024

Current Certification: 5th April 2022

John PRASAD

Director

ApprovalMark International Pty Ltd
18/33 Holbeche Road, Arndell Park 2148, Australia
www.approvalmark.com



WWW.JAS-ANZ.ORG/REGISTER



ApprovalMark

CERTIFICATION & TESTING: TUBE

Forza Copper tube has a Watermark license/certificate and is compliant to AS1432:2004 – Copper tubes for plumbing, gas fitting and drainage applications and AS/NZS 4020:2005- Testing of products for use in contact with drinking water.

Below is a list of tests performed to comply with watermark requirements :

DIMENSIONS AND TOLERANCES

- Mean outside diameter
 - Thickness
 - Ovality
-

PERFORMANCE AND TEST METHODS

- Contamination of water (complies with AS/NZS 4020)
- Hardness test
- Internal surface quality
- Watertightness





CERTIFICATE OF CONFORMITY

ApprovalMark International hereby grants:

Forza Global Pty Ltd
2/8 Barclay Road
Derrimut, VIC 3030
AUSTRALIA

WaterMark Certificate of Conformity – WMCS 2016

Evaluated to:

AS 1432: 2004 - Copper tubes for plumbing, gasfitting and drainage applications

The WaterMark licensee shall comply with all the terms and conditions as stipulated by the governance of the operating rules of WaterMark and shall comply with standard requirement at all times including when standard is amended. The WaterMark license only covers the product which is identified in the product schedule.

This certificate is issued by a JAS-ANZ accredited certification body. The ABCB and JAS-ANZ do not in any way warrant, guarantee or represent that the product the subject of this Certificate conforms to the WaterMark Certification Scheme Rules, nor accepts any liability arising out of the use of the product. The ABCB disclaims to the extent permitted by law, all liability (including negligence) for claims of losses, expenses, damages, and costs arising as a result of the use of the product(s) referred to in this certificate.

* This certificate may only be reproduced in its entirety.

Certificate No. WM 74717

Issued: 5th April 2022

Originally Certified: 21st April 2021

Expires: 21st April 2024

Current Certification: 5th April 2022

John PRASAD

Director
ApprovalMark International Pty Ltd
18/33 Holbeche Road, Arndell Park 2148, Australia
www.approvalmark.com



ApprovalMark

CLEARANCES BETWEEN FITTINGS

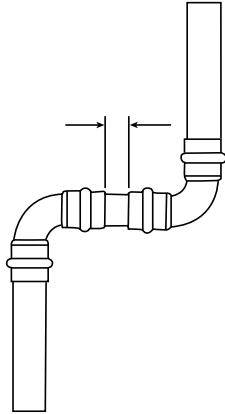

CLEARANCE BETWEEN TWO PRESS FITTINGS	
FITTING SIZE	MINIMUM CLEARANCE MM
DN15	5
DN20	5
DN25	5
DN32	10
DN40	20
DN50	20
DN65	15
DN80	15
DN100	15

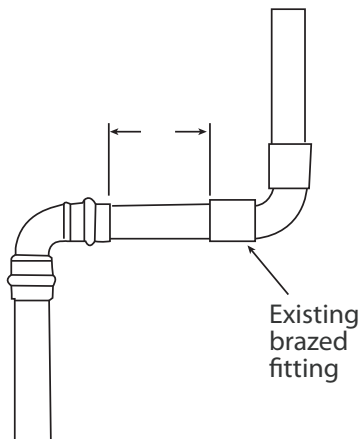

CLEARANCE BETWEEN PRESS FITTING AND EXISTING BRAZED FITTING	
FITTING SIZE	MINIMUM CLEARANCE MM
DN15	5
DN20	5
DN25	10
DN32	10
DN40	20
DN50	20
DN65	15
DN80	15
DN100	15

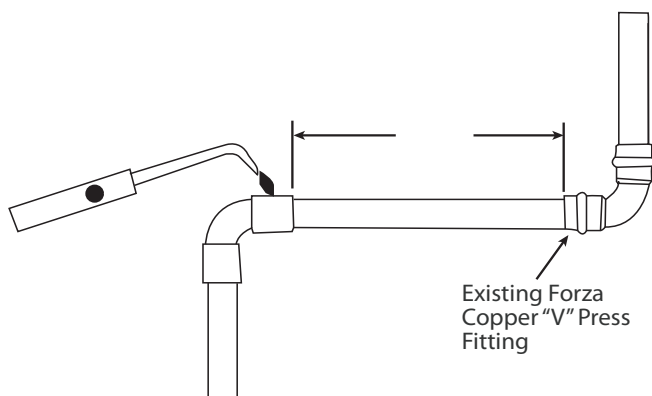

CLEARANCE BETWEEN A NEW BRAZED FITTING AND AN EXISTING PRESS FITTING	
FITTING SIZE	MINIMUM CLEARANCE MM
DN15	350
DN20	500
DN25	650
DN32	800
DN40	1000
DN50	1300
DN65	1650
DN80	2000
DN100	2500



COPPER TUBE SPECIFICATIONS

Forza Copper 'V' Press fittings are designed to be used with type A & B copper tube complying with AS1432. This includes hard drawn straight lengths, bendable quality straight lengths and annealed coils.

Forza Copper 'V' Press fittings can also be used on existing AS1432 compliant copper tube. Existing tube must be in reasonable condition. For the tube to be considered as being in reasonable condition the following observations must be made, that there is no surface damage, no signs of external corrosion and the tube should be of its original shape.

The below tables list copper tube that is suitable for use with Forza Copper 'V' Press fittings:

TYPE A									
NOMINAL SIZE	MEAN OD MM		THICKNESS MM			TEMPER	FORM	LENGTH	SAFE WORKING PRESSURE KPA @50°C
	DN	MIN.	MAX.	MIN.	NOMINAL				
15	12.62	12.70	0.88	1.02	1.17	BENDABLE	STRAIGHT	6M	6100
15	12.62	12.70	0.88	1.02	1.17	ANNEALED	COIL	18M	6100
20	18.97	19.05	1.21	1.42	1.63	BENDABLE	STRAIGHT	6M	5560
20	18.97	19.05	1.21	1.42	1.63	ANNEALED	COIL	18M	5560
25	25.30	25.40	1.39	1.63	1.88	HARD DRAWN	STRAIGHT	6M	4750
25	25.30	25.40	1.39	1.63	1.88	ANNEALED	COIL	18M	4750
32	31.65	31.75	1.39	1.63	1.88	HARD DRAWN	STRAIGHT	6M	3750
40	38.00	38.10	1.39	1.63	1.88	HARD DRAWN	STRAIGHT	6M	3100
50	50.67	50.80	1.39	1.63	1.88	HARD DRAWN	STRAIGHT	6M	2310
65	63.35	63.50	1.39	1.63	1.88	HARD DRAWN	STRAIGHT	6M	1840
80	76.02	76.20	1.73	2.03	2.33	HARD DRAWN	STRAIGHT	6M	1900
100	101.35	101.60	1.83	2.03	2.23	HARD DRAWN	STRAIGHT	6M	1500

TYPE B									
NOMINAL SIZE	MEAN OD MM		THICKNESS MM			TEMPER	FORM	LENGTH	SAFE WORKING PRESSURE KPA @50°C
	DN	MIN.	MAX.	MIN.	NOMINAL				
15	12.62	12.70	0.77	0.91	1.05	BENDABLE	STRAIGHT	6M	5290
15	12.62	12.70	0.77	0.91	1.05	ANNEALED	COIL	18M	5290
20	18.97	19.05	0.88	1.02	1.17	BENDABLE	STRAIGHT	6M	3970
20	18.97	19.05	0.88	1.02	1.17	ANNEALED	COIL	18M	3970
25	25.30	25.40	1.04	1.22	1.40	HARD DRAWN	STRAIGHT	6M	3500
25	25.30	25.40	1.04	1.22	1.40	ANNEALED	COIL	18M	3500
32	31.65	31.75	1.04	1.22	1.40	HARD DRAWN	STRAIGHT	6M	2780
40	38.00	38.10	1.04	1.22	1.40	HARD DRAWN	STRAIGHT	6M	2300
50	50.67	50.80	1.04	1.22	1.40	HARD DRAWN	STRAIGHT	6M	1710
65	63.35	63.50	1.04	1.22	1.40	HARD DRAWN	STRAIGHT	6M	1370
80	76.02	76.20	1.39	1.63	1.88	HARD DRAWN	STRAIGHT	6M	1520
100	101.35	101.60	1.47	1.63	1.79	HARD DRAWN	STRAIGHT	6M	1200

O-RING SELECTION CHART

PRESSURE (KPA) TEMP. (°C) WATER EPDM HT FKM GAS HNBR

WATER SUPPLY

HOT AND COLD POTABLE WATER	AUSTRALIAN WATERMARK APPROVED, N.B. WATERMARK CERTIFICATION FOR ALL PLUMBING PRODUCTS IS RESTRICTED 1400KPA AT 95°C	1600	120	●	●
SOLAR SYSTEMS (FLAT-PANEL COLLECTORS)	SYSTEM CAPABLE OF HANDLING 200°C AS A PEAK TEMPERATURE BUT NOT SUSTAINED TEMPERATURE OVER A PERIOD OF TIME.	1600	120	●	●
	SYSTEM OPERATES AT A SUSTAINED TEMPERATURE OF 200°	1600	200		●
CHILLED WATER (CLOSED SYSTEM)	CONTACT FORZA GLOBAL FOR OPEN SYSTEMS (INHIBITORS)	1600	≥-25	●	●
SPRING WATER	CONTACT FORZA GLOBAL (POSSIBLE WITH DRINKING WATER)	1600	120	●	●
FIRE SERVICES- FIRE SPRINKLER & HOSE REEL	CAPABLE OF HANDLING THE REQUIRED TEST PRESSURE OF 1700 KPA OR 1.5 TIMES THE DESIGN PRESSURE AS SPECIFIED BY AS2419.1	1600	120	●	●
STEAM	LOW PRESSURE STEAM EQUIPMENT	≤100	120	●	●
PUMP CIRCULATED HW SYSTEMS	COMPLIANT WITH EN 12828			●	●

ANTI-FREEZE / COROSSION PROTECTION / INHIBITORS

	PRODUCT	MANUFACTURER				
ANTI-FREEZE COOLING CONCENTRATION 50%	ETHYLENE GLYCOL	VARIOUS	1600	-25 TO 120	●	●
	PROPYLENE GLYCOL	VARIOUS	1600	-25 TO 120	●	●
	ANTIFROGEN N	CLARIANT	1600	-25 TO 120	●	●
	ANTIFROGEN L	CLARIANT	1600	-25 TO 120	●	●
	TYFOCOR	TYFOROP-CHEMIE	1600	-25 TO 120	●	●
	TYFOCOR L	TYFOROP-CHEMIE	1600	-25 TO 120	●	●

OTHER MEDIA

ETHANOL			1600	25	●	●
ACETONE	LIQUID		500	-10 TO 40	●	●
CONDENSATE	STEAM EQUIPMENT		1600	110	●	●
LEAKAGE INDICATOR LIQUID FOR OIL TANKS	BRENTAG R 36522		100	-20 TO 30	●	●

NATURAL GAS/ LPG

NATURAL GAS	AUSTRALIAN GAS APPROVED, N.B. AS/NZS5601 PERMITS USE UP TO 200 KPA FOR ALL SYSTEMS.		200	100		●
LPG	AUSTRALIAN GAS APPROVED, N.B. AS/NZS5601 PERMITS USE UP TO 200 KPA FOR ALL SYSTEMS		200	100		●

OILS, COOLING MATERIALS AND LUBRICANTS

ENGINE OILS AND LUBRICANTS (PETROLEUM-BASED SAE)	CONSULTATION REQUIRED		1000	70		●
HEATING OIL, DIESEL IN ACC. WITH EN590			500	40		●

OTHER GAS

OXYGEN	OIL AND FAT FREE		1200	60	●	●	●
CARBOGEN	CO ₂ + O ₂ DRY		1600	70	●		●
ARGON	FOR WELDING		1600	AMBIENT	●		●
COMPRESSED AIR	OIL CONCENTRATION ≤25 MG/M ³		1600	70	●	●	
	OIL CONCENTRATION ≥25 MG/M ³		1600	70			●
CARBON DIOXIDE – CO ₂	DRY		1600	70	●	●	●
CARBON MONOXIDE – CO	STAINLESS STEEL COMPONENTS NOT PERMITTED		1600	70	●	●	●
NITROGEN – N ₂	AFTER THE EVAPORATOR		1600	70	●	●	●
HYDROGEN – H ₂	WILL LEAK AT <0.001 CM ³ /MINUTE		500	70	●	●	●
FORMING GAS/WELDING GAS	80% ARGON / 20% CO ₂		1600	70	●	●	●
LOW VACUUM	P _{ABS} = 1MBAR				●	●	●
HELIUM – HE ₂			1600	70	●	●	●
XENON			1600	70	●	●	●
NEON			1600	70	●	●	●
KRYPTON			1600	70	●	●	●

NOT SUITABLE FOR: Refrigeration and Air Conditioning Applications, Acetylene, Urea Solution, Methanol, Glycerine Triacetate, Coolant Inhibitor, Sodium Hydroxide, Amoniac (gaseous), Medical Gas Applications.

EPDM - Ethylene Propylene Diene Monomer FKM - Fluorocarbon Rubber HNBR - Hydrogenated Nitrile Butadiene Rubber

COPPER "V" PRESS FITTINGS LIST

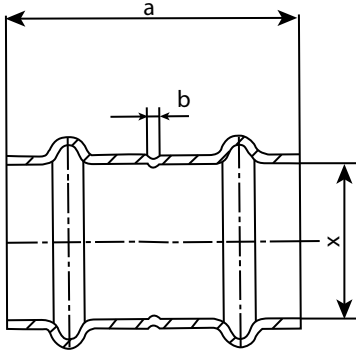

COUPLING

WATER CODE	GAS CODE	HT CODE	a	b	x
FCPWC15	FCPGC15	FCPHTC15	38	2	15
FCPWC20	FCPGC20	FCPHTC20	47	2	20
FCPWC25	FCPGC25		48	2	25
FCPWC32	FCPGC32		54	3	32
FCPWC40	FCPGC40		66	3	40
FCPWC50	FCPGC50		82	3	50

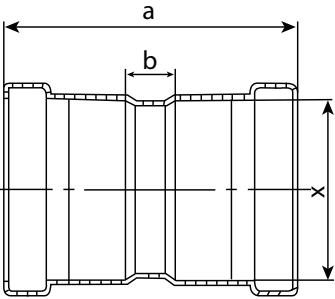

COUPLING

WATER CODE	GAS CODE	a	b	x
FCPWC65	FCPGC65	108	20	65
FCPWC80	FCPGC80	122	20	80
FCPWC100	FCPGC100	148	28	100

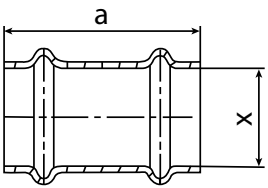

SLIP COUPLING

WATER CODE	GAS CODE	HT CODE	a	x
FCPWSLC15	FCPGSLC15	FCPHTSLC15	38	15
FCPWSLC20	FCPGSLC20	FCPHTSLC20	50	20
FCPWSLC25	FCPGSLC25		50	25
FCPWSLC32	FCPGSLC32		58	32
FCPWSLC40	FCPGSLC40		66	40
FCPWSLC50	FCPGSLC50		82	50

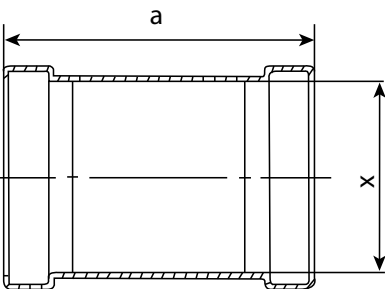

SLIP COUPLING

WATER CODE	GAS CODE	HT CODE	a	x
FCPWSLC65	FCPGSLC65		108	65
FCPWSLC80	FCPGSLC80		122	80
FCPWSLC100	FCPGSLC100		148	100

COPPER "V" PRESS FITTINGS LIST

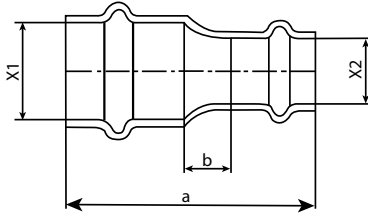

REDUCING COUPLING

WATER CODE	GAS CODE	a	b	X1	X2
FCPWRC2015	FCPGRC2015	48.5	9	20	15
FCPWRC2515	FCPGRC2515	55	15.5	25	15
FCPWRC2520	FCPGRC2520	54	8	25	20
FCPWRC3215	FCPGRC3215	60	16.5	32	15
FCPWRC3220	FCPGRC3220	63	14	32	20
FCPWRC3225	FCPGRC3225	58	9	32	25
FCPWRC4020	FCPGRC4020	71	16.5	40	20
FCPWRC4025	FCPGRC4025	68	13.5	40	25
FCPWRC4032	FCPGRC4032	67	9	40	32
FCPWRC5020	FCPGRC5020	87	24	50	20
FCPWRC5025	FCPGRC5025	84	21	50	25
FCPWRC5032	FCPGRC5032	83	17	50	32
FCPWRC5040	FCPGRC5040	85	13	50	40

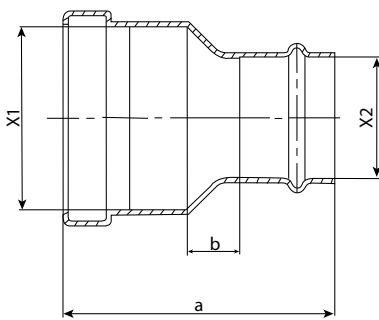

REDUCING COUPLING

WATER CODE	GAS CODE	a	b	X1	X2
FCPWRC6532	FCPGRC6532	94	25	65	32
FCPWRC6540	FCPGRC6540	97	22	65	40
FCPWRC6550	FCPGRC6550	100	17	65	50
FCPWRC8040	FCPGRC8040	112.5	28.5	80	40
FCPWRC8050	FCPGRC8050	114	22	80	50
FCPWRC10050	FCPGRC10050	135	35	100	50

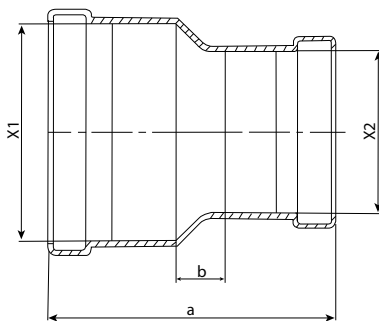

REDUCING COUPLING

WATER CODE	GAS CODE	a	b	X1	X2
FCPWRC8065	FCPGRC8065	110	15	80	65
FCPWRC10065	FCPGRC10065	131	28	100	65
FCPWRC10080	FCPGRC10080	135	23	100	80

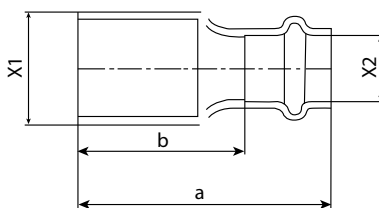

REDUCER

WATER CODE	GAS CODE	a	b	X1	X2
FCPWRF2015	FCPGRMF2015	50	33.5	20	15
FCPWRF2515	FCPGRMF2515	55	38.5	25	15
FCPWRF2520	FCPGRMF2520	55	32	25	20
FCPWRF3220	FCPGRMF3220	64	41	32	20
FCPWRF3225	FCPGRMF3225	62	39	32	25
FCPWRF4020	FCPGRMF4020	73	50	40	20
FCPWRF4025	FCPGRMF4025	71	48	40	25
FCPWRF4032	FCPGRMF4032	69	42	40	32
FCPWRF5025	FCPGRMF5025	85	62	50	25
FCPWRF5032	FCPGRMF5032	86	60	50	32
FCPWRF5040	FCPGRMF5040	88	56	50	40

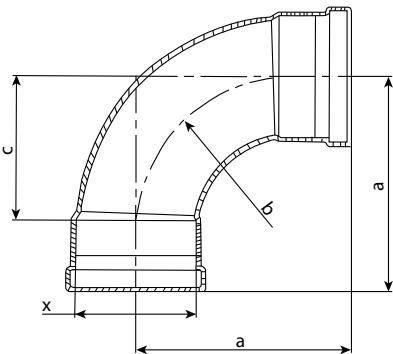
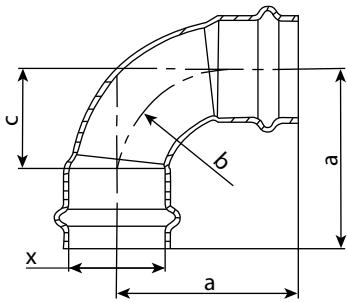
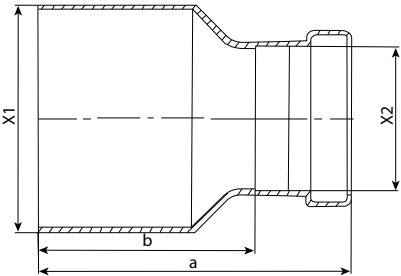
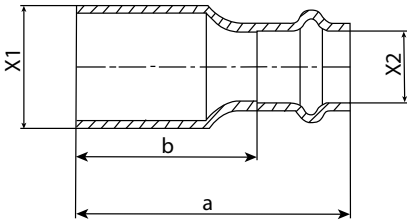

REDUCER

WATER CODE	GAS CODE	a	b	X1	X2
FCPWRMF6540	FCPGRMF6540	102	70	65	40
FCPWRMF6550	FCPGRMF6550	104	64	65	50
FCPWRMF8040	FCPGRMF8040	120	88	80	40
FCPWRMF8050	FCPGRMF8050	120	80	80	50
FCPWRMF10050	FCPGRMF10050	142	102	100	50

REDUCER

WATER CODE	GAS CODE	a	b	X1	X2
FCPWRMF8065	FCPGRMF8065	118	75	80	65
FCPWRMF10065	FCPGRMF10065	140	97	100	65
FCPWRMF10080	FCPGRMF10080	144	92	100	80

ELBOW

WATER CODE	GAS CODE	HT CODE	a	b	c	x
FCPWE15	FCPGE15	FCPHTE15	30	15.2	13.5	15
FCPWE20	FCPGE20	FCPHTE20	42	22.8	19	20
FCPWE25	FCPGE25		53.5	30.5	30.5	25
FCPWE32	FCPGE32		59	38.2	33	32
FCPWE40	FCPGE40		76	45.7	44.5	40
FCPWE50	FCPGE50		97	61	57	50

ELBOW

WATER CODE	GAS CODE	a	b	c	x
FCPWE65	FCPGE65	121	76.4	76.4	65
FCPWE80	FCPGE80	147	95.1	95	80
FCPWE100	FCPGE100	180	132.1	120	100

COPPER "V" PRESS FITTINGS LIST

ELBOW M + F

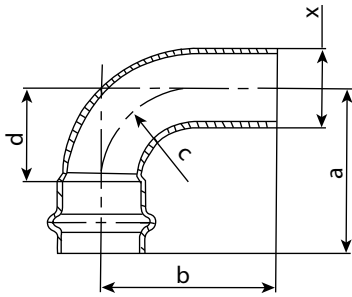

WATER CODE	GAS CODE	a	b	c	d	x
FCPWEMF15	FCPGEMF15	30	36	15.2	13.5	15
FCPWEMF20	FCPGEMF20	42	48	22.8	19	20
FCPWEMF25	FCPGEMF25	53.5	56.5	30.5	30.5	25
FCPWEMF32	FCPGEMF32	64.2	66.2	38.2	38.2	32
FCPWEMF40	FCPGEMF40	76	79.7	45.7	44.5	40
FCPWEMF50	FCPGEMF50	97	103	61	57	50

ELBOW M + F

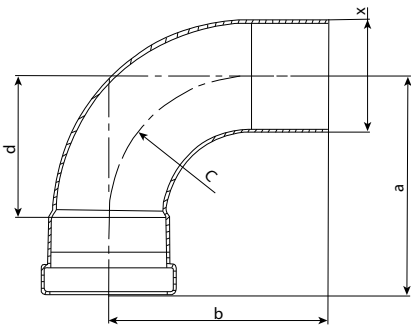

WATER CODE	GAS CODE	a	b	c	d	x
FCPWEMF65	FCPGEMF65	121	126.2	76.4	76.4	65
FCPWEMF80	FCPGEMF80	147	155.1	95.1	95	80
FCPWEMF100	FCPGEMF100	180	196.5	132.1	120	100

45° ELBOW

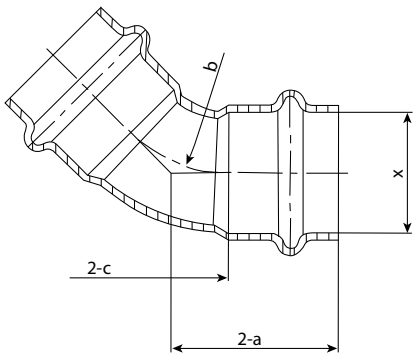

WATER CODE	GAS CODE	a	b	c	x
FCPW45E15	FCPG45E15	24	15.2	7.5	15
FCPW45E20	FCPG45E20	31.4	22.8	8.4	20
FCPW45E25	FCPG45E25	35	30.5	12	25
FCPW45E32	FCPG45E32	31	38.2	15	32
FCPW45E40	FCPG45E40	50.4	45.7	18.9	40
FCPW45E50	FCPG45E50	65.3	61	25.3	50

45° ELBOW

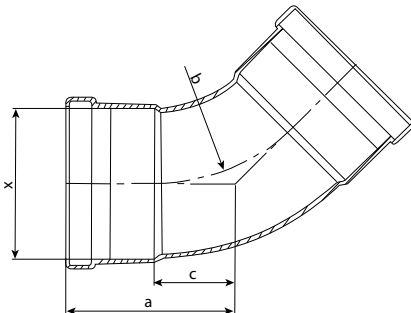

WATER CODE	GAS CODE	a	b	c	x
FCPW45E65	FCPG45E65	75.5	76.4	31.6	65
FCPW45E80	FCPG45E80	89.2	95.1	37.2	80
FCPW45E100	FCPG45E100	114.7	132.1	54.7	100

45° ELBOW M + F

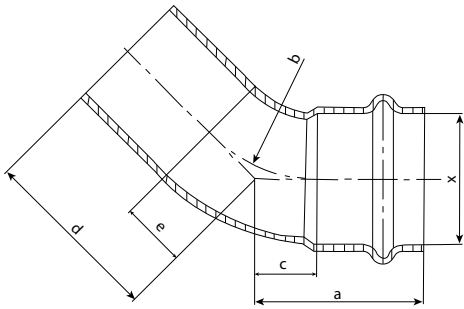

WATER CODE	GAS CODE	a	b	c	d	e	x
FCPW45EMF15	FCPG45EMF15	24	15.2	7.5	27.3	6.3	15
FCPW45EMF20	FCPG45EMF20	31.4	22.8	8.4	34.5	9.5	20
FCPW45EMF25	FCPG45EMF25	35	30.5	12	37.6	12.6	25
FCPW45EMF32	FCPG45EMF32	31	38.2	15	43.8	15.8	32
FCPW45EMF40	FCPG45EMF40	50.4	45.7	18.9	52.4	18.9	40
FCPW45EMF50	FCPG45EMF50	65.3	61	25.3	67.3	25.3	50

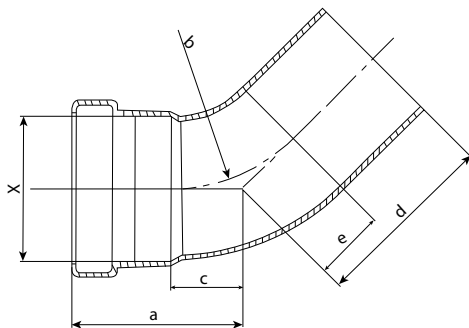

45° ELBOW M + F

WATER CODE	GAS CODE	a	b	c	d	e	x
FCPW45EMF65	FCPG45EMF65	75.5	76.2	31.6	81.6	31.6	65
FCPW45EMF80	FCPG45EMF80	89.2	95.1	37.2	99.4	39.4	80
FCPW45EMF100	FCPG45EMF100	114.7	132.1	54.7	124.7	54.7	100

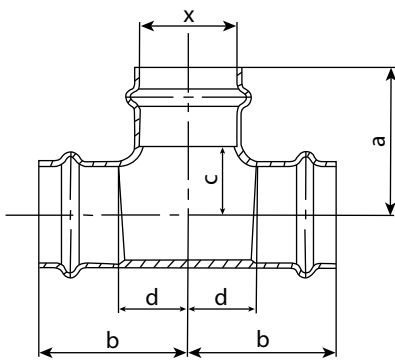

EQUAL TEE

WATER CODE	GAS CODE	HT CODE	a	b	c	d	x
FCPWET15	FCPGET15	FCPHTET15	28	31	11.5	14.5	15
FCPWET20	FCPGET20	FCPHTET20	36	39	13	15.1	20
FCPWET25	FCPGET25		41.5	43	18.5	19.1	25
FCPWET32	FCPGET32		48.5	48.5	22.5	22.5	32
FCPWET40	FCPGET40		57	57	25.5	25.5	40
FCPWET50	FCPGET50		71	71	31	31	50

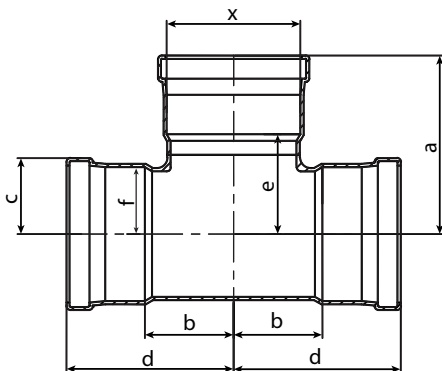

EQUAL TEE LARGE

WATER CODE	GAS CODE	a	b	c	d	e	f	x
FCPWET65	FCPGET65	97.8	44.4	39.1	89	54.8	34.3	65
FCPWET80	FCPGET80	112	48	45.1	100	60.8	40.5	80
FCPWET100	FCPGET100	136.2	68	58	128	76.2	53.7	100

COPPER "V" PRESS FITTINGS LIST

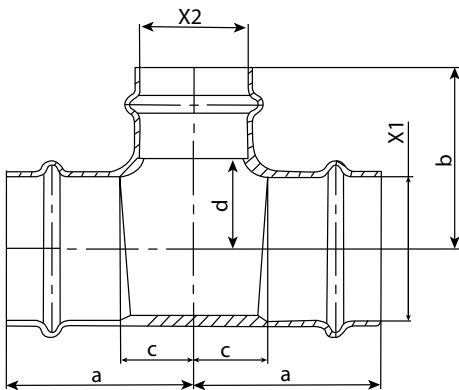

REDUCING TEE

WATER CODE	GAS CODE	a	b	c	d	x1	x2
FCPWRT202015	FCPGRT202015	36.5	32	13.5	15.5	20	15
FCPWRT252515	FCPGRT252515	36.5	35.5	13.5	19	25	15
FCPWRT252520	FCPGRT252520	39.5	40.5	16.5	17.5	25	20
FCPWRT323215	FCPGRT323215	40	39.5	14	23	32	15
FCPWRT323220	FCPGRT323220	43.5	43.5	17.5	20.5	32	20
FCPWRT323225	FCPGRT323225	48.5	45.5	22.5	22.5	32	25
FCPWRT404020	FCPGRT404020	46.5	47.5	14.5	24.5	40	20
FCPWRT404025	FCPGRT404025	51.5	50.5	19.5	27.5	40	25
FCPWRT404032	FCPGRT404032	55	52	23.5	26	40	32
FCPWRT505020	FCPGRT505020	57	56	17	33	50	20
FCPWRT505025	FCPGRT505025	59.5	57.5	19.5	34.5	50	25
FCPWRT505032	FCPGRT505032	62.5	59.5	22.5	33.5	50	32
FCPWRT505040	FCPGRT505040	66	64	26	32	50	40

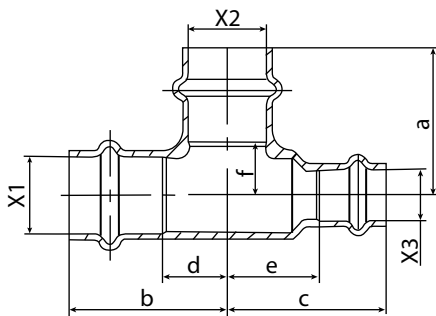

REDUCING TEE

WATER CODE	GAS CODE	a	b	c	d	e	f	x1	x2	x3
FCPWRT201520	FCPGRT201520	36	39	39	16	22.5	13	20	20	15
FCPWRT201515	FCPGRT201515	32	36.5	36.3	13.5	19.8	15.5	20	15	15

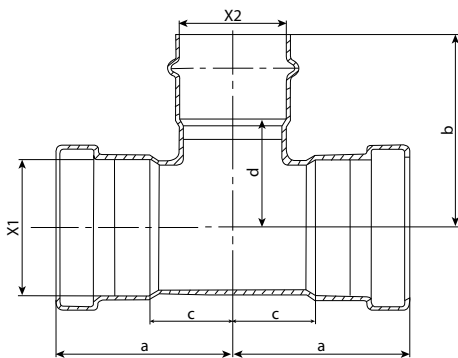

REDUCING TEE

WATER CODE	GAS CODE	a	b	c	d	x1	x2
FCPWRT656550	FCPGRT656550	84	92	41	52	65	50
FCPWRT808050	FCPGRT808050	89	98	37	58	80	50
FCPWRT10010040	FCPGRT10010040	96	102	36	70	100	40
FCPWRT10010050	FCPGRT10010050	102.5	111	42.5	71	100	50

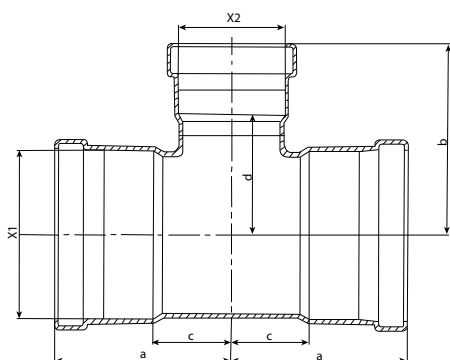

REDUCING TEE

WATER CODE	GAS CODE	a	b	c	d	x1	x2
FCPWRT808065	FCPGRT808065	93	104	41	61	80	65
FCPWRT10010065	FCPGRT10010065	107	117	47	75	100	65
FCPWRT10010080	FCPGRT10010080	114	126	54	74	100	80

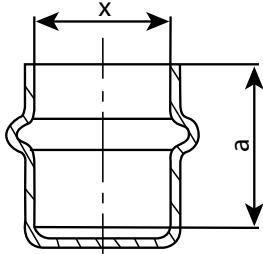

END CAP

WATER CODE	GAS CODE	HT CODE	a	x
FCPWEC15	FCPGEC15	FCPHTEC15	16.5	15
FCPWEC20	FCPGEC20	FCPHTEC20	23	20
FCPWEC25	FCPGEC25		23	25
FCPWEC32	FCPGEC32		26	32
FCPWEC40	FCPGEC40		32	40
FCPWEC50	FCPGEC50		40	50

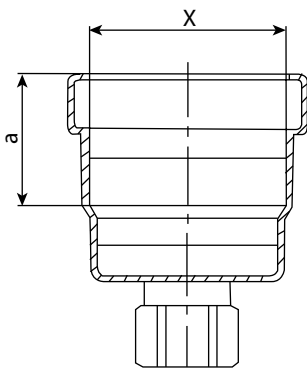

END CAP

WATER CODE	GAS CODE	a	x
FCPWEC65	FCPGEC65	43	65
FCPWEC80	FCPGEC80	52	80
FCPWEC100	FCPGEC100	60	100

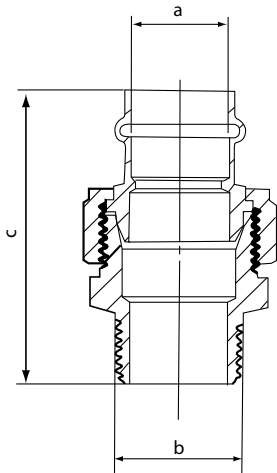

SWIVEL UNION MALE

WATER CODE	GAS CODE	a	b	c
FCPWMSU2525	FCPGMSU2525	25.8	1"	78
FCPWMSU3232	FCPGMSU3232	32.2	1-1/4"	80
FCPWMSU4040	FCPGMSU4040	38.5	1-1/2"	88.5
FCPWMSU5050	FCPGMSU5050	51.3	2"	104

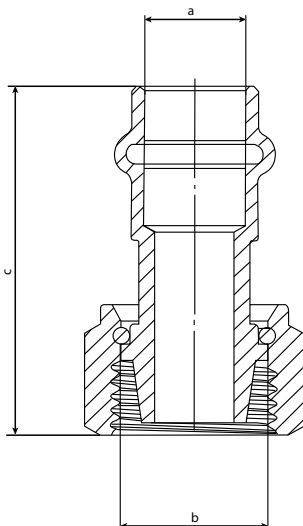

SWIVEL NUT CONNECTOR

WATER CODE	GAS CODE	a	b	c
FCPWSNF1515	FCPGSNF1515	12.85	G1/2-14	44
FCPWSNF2020	FCPGSNF2020	19.25	G3/4-14	53.6

COPPER "V" PRESS FITTINGS LIST

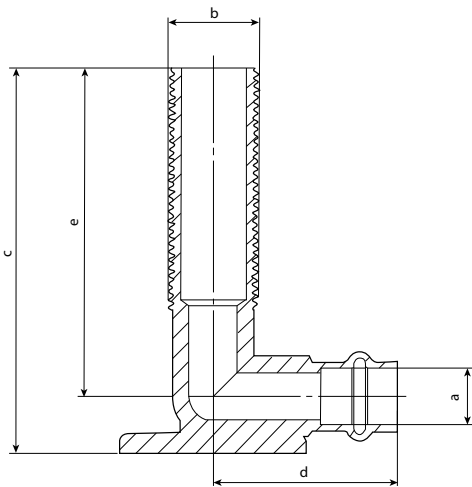

MALE LUGGED ELBOW

WATER CODE	GAS CODE	a	b	c	d	e
FCPWWM151575	FCPGWM151575	12.85	1/2"	88	42	75
FCPWWM151590	FCPGWM151590	12.85	1/2"	103	42	90

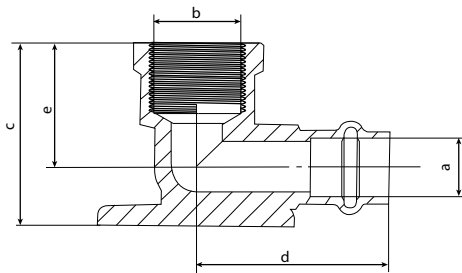

FEMALE LUGGED ELBOW

WATER CODE	GAS CODE	a	b	c	d	e
FCPWWF1515	FCPWWF1515	12.85	1/2"	40	42	27
FCPWWF2020	FCPGWF2020	19.25	3/4"	43.5	46	29.5
FCPWWF2015	FCPGWF2015	19.25	1/2"	41	46	27

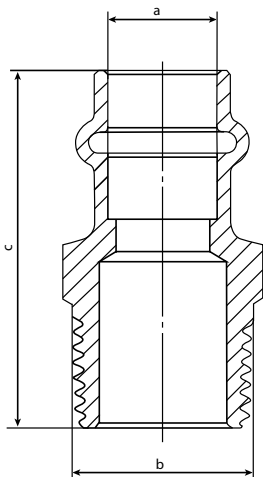

MALE STRAIGHT CONNECTOR

WATER CODE	GAS CODE	HT CODE	a	b	c
FCPWMSC1515	FCPGMSC1515	FCPHTMSC1515	12.85	1/2"	42
FCPWMSC2020	FCPGMSC2020	FCPHTMSC2020	19.25	3/4"	48
FCPWMSC2525	FCPGMSC2525		25.8	1"	52.5
FCPWMSC3232	FCPGMSC3232		32.2	1-1/4"	56.5
FCPWMSC4040	FCPGMSC4040		38.5	1-1/2"	64.5
FCPWMSC5050	FCPGMSC5050		51.3	2"	78
FCPWMSC1520	FCPGMSC1520	FCPHTMSC1520	12.85	3/4"	16
FCPWMSC2015	FCPGMSC2015		19.25	1/2"	44.5
FCPWMSC2520	FCPGMSC2520		25.8	3/4"	47

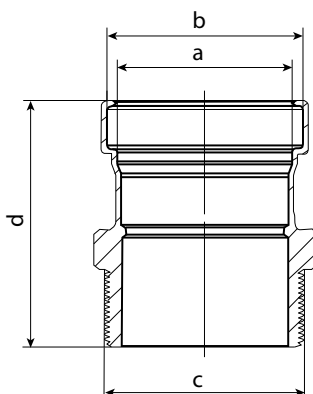

MALE STRAIGHT CONNECTOR

WATER CODE	a	b	c	d
FCPWMSC6565	66.5	74.5	2-1/2"	93
FCPWMSC8080	78.5	86.5	3"	100

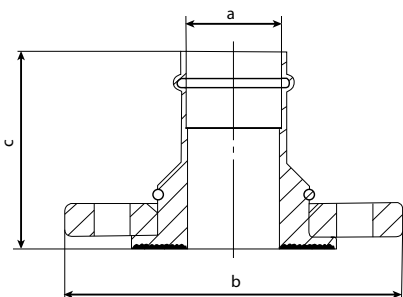
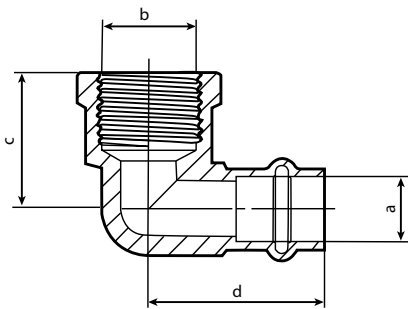
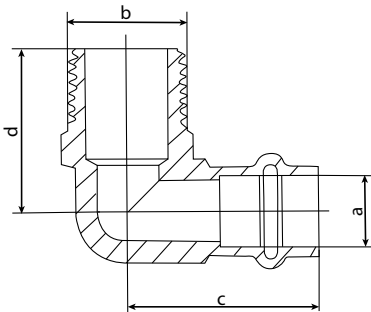
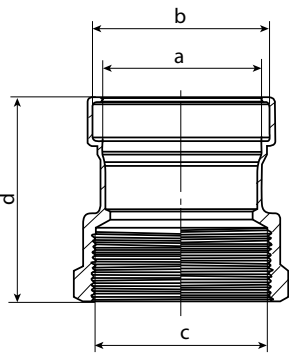
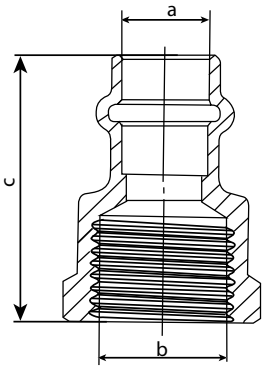

FEMALE STRAIGHT CONNECTOR

WATER CODE	GAS CODE	HT CODE	a	b	c
FCPWFC1515	FCPGFSC1515	FCPHTFSC1515	12.85	1/2"	39
FCPWFC2020	FCPGFSC2020	FCPHTFSC2020	19.25	3/4"	44
FCPWFC2525	FCGFSC2525		25.8	1"	48
FCPWFC3232	FCPGFSC3232		32.2	1-1/4"	52
FCPWFC4040	FCPGFSC4040		38.5	1-1/2"	58
FCPWFC5050	FCPGFSC5050		51.3	2"	70.5

FEMALE STRAIGHT CONNECTOR

WATER CODE	a	b	c	d
FCPWFC6565	66.5	74.5	2-1/2"	86

MALE ELBOW

WATER CODE	GAS CODE	a	b	c	d
FCPWME1515	FCPGME1515	12.85	1/2"	34	29
FCPWME2020	FCPGME2020	19.25	3/4"	40.5	34

FEMALE ELBOW

WATER CODE	GAS CODE	a	b	c	d
FCPWFE1515	FCPGFE1515	12.85	1/2"	27	35
FCPWFE2020	FCPGFE2020	19.25	3/4"	31	42
FCPWFE2015	FCPGFE2015	19.25	1/2"	30	40

FLANGE ADAPTOR

WATER CODE	GAS CODE	a	b	c
FCPWFA40	FCPGFA40	38.5	135	79
FCPWFA50	FCPGFA50	51.3	150	86
FCPWFA65	FCPGFA65			
FCPWFA80	FCPGFA80			
FCPWFA100	FCPGFA100			

FORZA COPPER "V" PRESS DN15-50 INSTALLATION INSTRUCTIONS

The following instructions explain the correct installation procedure for FORZA copper press fittings with copper tube that complies with AS1432.



With the use of a tube cutter, cut copper tube to the desired length.



Next using a deburring tool, deburr the end of the tube that will be inserted into the fitting.



If connecting to existing copper tube to AS1432. Ensure tube is clean by way of soft scourer or emery paper.



Check that you have the correct fitting for the application. Water will have a black 'O' ring, gas will have a yellow 'O' ring and High temp. will have a red 'O' ring.



Line up tube with fitting and place a mark on the tube at the correct insertion depth.



When tube is inserted mark should line up with back of fitting.



Insert the correct size press jaw for the size of fitting being pressed. Ensure jaw is clean and moves freely.

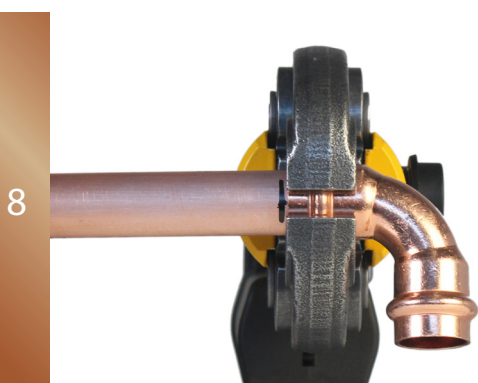

Line up the jaw of the tool so the centre of the jaw lines up with the raised section of the fitting.

FORZA COPPER "V" PRESS DN15-50 INSTALLATION INSTRUCTIONS

The following instructions explain the correct installation procedure for FORZA copper press fittings with copper tube that complies with AS1432.

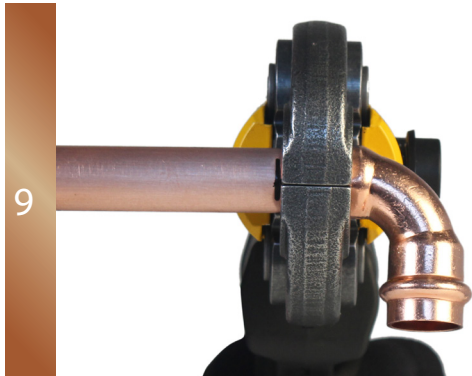

Press the trigger on the tool, hold down until jaws fully close and an audible click is heard. This completes the pressing process.



Inspect fitting to ensure press is complete.

FORZA COPPER "V" PRESS DN65-100 INSTALLATION INSTRUCTIONS



Using a fine tooth saw or tube cutter, cut copper tube to the desired length.



Using a smooth file deburr and clean the end of the tube both internally and externally to minimise turbulence and pressure loss. This will also avoid damage to the O-ring.



Check fitting to ensure it is suitable for the application. Confirm that fitting is clean and the O-ring and stainless grip ring are free from debris.



Line up the fitting with the tube and place a mark on the tube at the correct insertion depth.

FORZA COPPER "V" PRESS DN65-100 INSTALLATION INSTRUCTIONS



Place fitting onto tube ensuring the mark on the tube lines up with the outer edge of the fitting.



Select the correct sized collar, making sure that pressing area is clean and smooth.



Place the collar over the fitting and check that the fitting sits squarely inside the pressing area of collar.



Place the adaptor jaw in the tool and ensure pin is pushed into place to hold jaw.

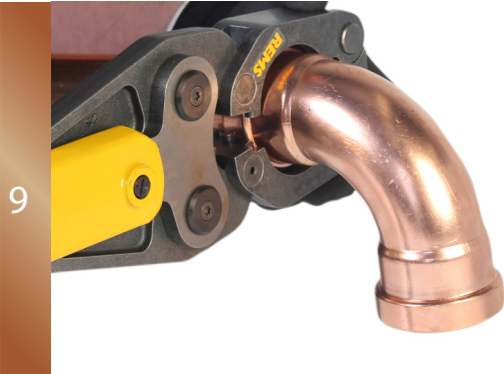

Place the adaptor jaw over the pins on the collar, check that the fitting is still matching up to the insertion depth mark on the tube. Press the trigger on the tool and hold down until piston retracts.



Remove the adaptor jaw from the collar, then the collar from the fitting. Now you can remove the sticker from the fitting to confirm press is complete.

TOOL DESCRIPTIONS COPPER PRESS

AKKU-PRESS

Compact, handy, light. Drive unit with battery only 4.3 kg. Works anywhere, free-hand, overhead, in confined areas. The Akku-Press battery tool ensures superior joints are made when used on Forza Copper 'V' Press fittings.

Combining electro hydraulic drive with powerful battery motor, robust planetary gear, eccentric reciprocating pump and compact hydraulic system enables the Akku-Press to easily join Forza Copper 'V' Press fittings from DN15 right up to DN100.



MINI-PRESS

Super light, super small, super handy. Drive unit with battery only 2.4 kg. Optimum weight distribution for single-hand operation. The Mini-Press battery tool provides a safe and efficient method of making joints on Forza Copper 'V' Press fittings. Tool is suitable for pressing Forza Copper 'V' Press fittings from DN15 to DN32.



MINI-PRESS S 22 V ACC

The REMS Mini-Press S 22V ACC is super light, super small, super handy and super fast. The production of press connections 10-40mm. The new 22 V Technology sets standards in terms of economy and user friendliness and allows the user to perform super-rapid pressing in under 4 seconds with 50% more pressing power.

COMPATIBLE JAWS AND PRESS COLLARS

BRAND	DN15	DN20	DN25	DN32	DN40	DN50	DN65	DN80	DN100
REMS	YES	YES	YES	YES	YES	YES	YES	YES	YES
VIEGA	YES	YES	YES	YES	YES	YES	YES	YES	YES
KEMPRESS	YES	YES	YES	YES	YES	YES	YES	YES	YES
NOVOPRESS	YES	YES	YES	YES	YES	YES	YES	YES	YES
ROTHENBERGER	YES	YES	YES	YES	YES	YES	YES	YES	YES



Forza Copper Press tube and fittings are guaranteed against manufacturing defects for a period of 25 YEARS when installed and used in accordance of the Australian Plumbing code and or the LOCAL or STATE Authority and when installed by a licensed PLUMBER.



Forza Copper Press tube complies with the standards as set out in AS1432-2004 Copper tubes for plumbing, gas fitting and drainage applications.

Forza Copper Press fittings complies with the standards as set out in AS3688:2016 Water Supply and gas systems - Metallic fittings and end connectors.

*The Forza Global warranty only applies to installations whereby a document can be provided detailing that the installation has been pressure tested to AS/NZS 3500 for water applications and AS/NZS 5601 for gas applications.

a product by



Allianz Australia Insurance Limited

General & Products Liability Insurance Certificate of Currency

This Certificate of Currency has been issued by Allianz Australia Insurance Limited and confirms that on the Date of Issue the Policy is current for the Period of Insurance and Limit of Liability as shown herein. This Certificate of Currency is issued as a matter of information only and confers no rights upon its holder.

This Certificate of Currency does not form part of the terms and conditions of the Policy and does not amend, extend, replace or alter the terms, conditions, definitions, limitations and exceptions noted therein.

This Certificate of Currency is provided as a summary only of the cover provided and is current only at the Date of Issue. The Policy may be subsequently altered or cancelled in accordance with its terms after the Date of Issue of this notice without further notice to the holder of this notice.

Certain words used in this document and the Policy have special meanings. The Definitions section of the Policy document contains such terms. Please read the Policy wording, the Schedule and any other documents that form part of the Policy for the terms and conditions of cover.

NAMED INSURED:	Forza Global Pty Ltd
POLICY NUMBER:	22-0127810-LCP
PERIOD OF INSURANCE:	22 nd January 2022 to 4pm 22 nd January 2023
LIMIT OF LIABILITY:	\$50,000,000 per Occurrence or per Occurrence and in the aggregate (as applicable), in accordance with the Policy terms and conditions
POLICY WORDING:	Steadfast General & Products Liability Policy POL255BA/SF 02/21
GEOGRAPHICAL LIMITS:	Anywhere in the world (subject to limitations of the Policy)

Kailin Gianikouris
Senior Liability Underwriter – Tailored Lines

Date of Issue: Issued on 2nd February 2022 for and on behalf of Allianz Australia Insurance Limited



FORZA GLOBAL PTY LTD
ABN 42 161 669 549 ACN 161 669 549
73 WENTWORTH PLACE, BANYO 4014 QLD
T: 1300 110 502 F: (03) 9923 6324
WWW.FORZAGLOBAL.COM.AU
