

Assembly Instructions

Please read these instructions carefully before starting the assembly & ensure you have all parts as per the parts list. Place all parts on a clean flat surface, such as carpet or rug to prevent from being scratched. This package contains small parts, keep away from children & babies.

Tools Required

Phillips 100mm Drill Bit

Parts List



**CAM
LOCK
SCREWS**
x 18



**CAM
DOWEL
SCREWS**
x 18



SCREWS
x 5



**SCREW
STICKERS**
x 5

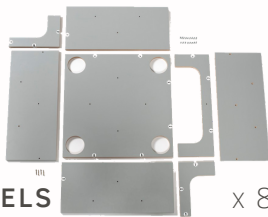

PANELS x 8

Cylinder packers, double sided tape and screw stickers are included with the kit & should be used if required for strap bracing.

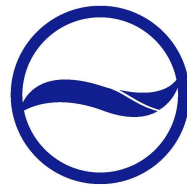

Contact Us:



www.aqualine.co.nz



sales@aqualine.co.nz

Assembly Instructions

Steps:



1 Attach the cross braces to form the stand by securing the cam locks in the centre. Note which edge has no cam lock.

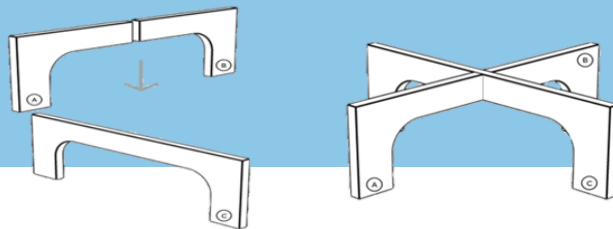

Q Cylinder Quick.

2 Attach the top square panel by securing the cam locks ensuring the edge of the panel without the cam locks aligns to the leg edge without cam locks.

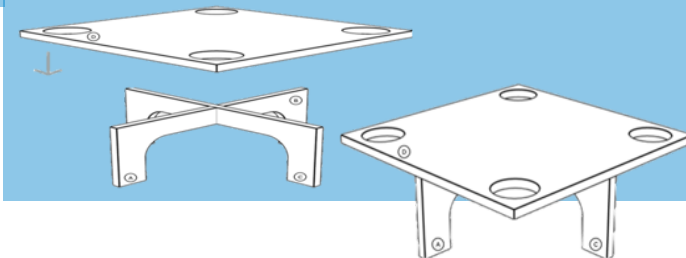

3 Locate the 'back' rectangular panel (has 5 cam lock holes on one side & no screw holes). Lay it flat on the floor (cam lock holes facing upwards). Stand the panel on top, aligning and securing the 3x cam locks.

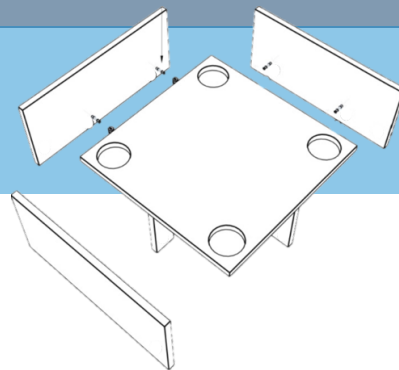

4 Attach both side pieces, cam lock down & facing inwards. Secure 3x cam locks on each.

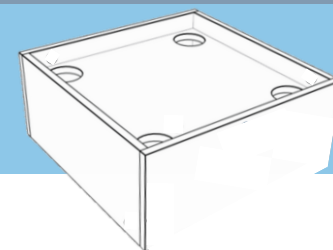

5 Stand box upright and fit tray into place.



6 Once cylinder fitted, attach the front panel to the box, using 5x screws. Place the screw stickers over screw holes if desired. Cylinder packers & double sided tape also included, if required.