

# EQUIPMENT

Clean, Prep,  
Cook, Hold &  
Merchandise





- ✓ **SAVES TIME**
- ✓ **SAVES LABOR**
- ✓ **MORE VERSATILITY**
- ✓ **MORE PROFIT**

## GLASS WASHERS



A-200



A-200 & A-205-P

- ◆ Five spinning brushes (four 6" brushes and one 6-3/4" center brush) clean inside and out simultaneously for crystal clear glassware



### BAR MAID® GLASS WASHERS

- ◆ Quiet, powerful 1/3 HP enclosed motor with sealed lower bearing and exclusive Splashguard canopy
- ◆ Automatic overload safety & ground fault protection plug
- ◆ Heavy bronze bearings and stainless steel construction

ITEM	OVERALL DIMENSIONS L" x D" x H" (mm)	POWER	PLUG	SHIP WEIGHT
A-200	12 x 8 x 18 (305 x 203 x 457)	115V-60Hz, 440W, 4.3A,	NEMA 5-15P, G.F.C.I. included	27 lbs (12.2 kgs)
A-205-P		*220-230V- 50/60Hz,	Type E, G.F.C.I. not included	23 lbs (10.4 kgs)



ITEM	DESCRIPTION	UOM	CASE
A-200	Upright Glass Washer, 115V	Box	1
A-205-P	Upright Glass Washer, 220V, International	Box	1



SS-100



SS-100



### BAR MAID® SUBMERSIBLE GLASS WASHER

- ◆ Compact design fits under bars even if space is tight
- ◆ Heavy-duty stainless steel construction and bronze bearings deliver outstanding performance and reliability
- ◆ Submersible 1/3 HP motor with automatic overload and ground fault protection plug

ITEM	OVERALL DIMENSIONS L" x D" x H" (mm)	POWER	PLUG	SHIP WEIGHT
SS-100	12 x 8 x 12 (305 x 203 x 305)	115V-60Hz, 440W, 4.3A,	NEMA 5-15P, G.F.C.I. included	27 lbs (12.2 kgs)



ITEM	DESCRIPTION	UOM	CASE
SS-100	Submersible Glass Washer, 115V	Box	1



# NOTHING CLEANS GLASSWARE FASTER OR BETTER



- ◆ Five spinning brushes (four 6" brushes and one 6-3/4" center brush) clean inside and out simultaneously for crystal clear glassware

## **BAR MAID® GLASS PRO™ GLASS WASHER**

- ◆ Heavy duty stainless steel construction
- ◆ 1/3 HP motor with automatic overload and ground fault protection plug

ITEM	OVERALL DIMENSIONS L" x D" x H" (mm)	POWER	PLUG	SHIP WEIGHT
AA	12 x 8 x 17-3/4 (305 x 203 x 450)	115V-60Hz, 440W, 4.3A	NEMA 5-15P, G.F.C.I. included	27 lbs (12.2 kgs)

ITEM	DESCRIPTION	UOM	CASE
AA	Upright Glass Washer, 115V	Box	1



## GLASS WASHERS



AA



AA-SERIES

## **BAR MAID® GLASS PRO™ SUBMERSIBLE GLASS WASHER**

ITEM	OVERALL DIMENSIONS L" x D" x H" (mm)	POWER	PLUG	SHIP WEIGHT
AA-SUB	12 x 8 x 11 (305 x 203 x 280)	115V-60Hz, 440W, 4.3A	NEMA 6-15P, G.F.C.I. included	27 lbs (12.2 kgs)

ITEM	DESCRIPTION	UOM	CASE
AA-SUB	Submersible Glass Pro Glass Washer, 115V	Box	1



Sparkling Clean



AA-SUB



AA-SERIES





# GENTLE, EFFECTIVE CLEANING

## GLASS WASHER BRUSHES



BRS-980



BRS-732SG



BRS-920



BRS-922



BRS-975



BRS-976



BRS-950



BRS-930



BRS-935

### BAR MAID® GLASS WASHER BRUSHES

ITEM	DESCRIPTION	TYPE	UOM	CASE
BRS-732SG	Shot Glass Brush	Pinned	Each	1/18
BRS-980	4" Scrub Brush, For Muffin Pans	Pinned	Each	1/6
BRS-917	6" Standard Brush	Pinned	Each	1/18
BRS-920	6-3/4", For Slightly Taller Glassware	Pinned	Each	1/18
BRS-922	7-1/2", For Taller Glassware	Pinned	Each	1/18
BRS-975	8-1/2", For Extra Tall Glassware	Pinned	Each	1/18
BRS-975S	8-1/2" Softie® Brush, For Delicate Extra-Tall Glassware	Pinned	Each	1/18
BRS-976	9" Pilsner Brush	Pinned	Each	1/18
BRS-950	Margarita & Martini Glass Brush	Pinned	Each	1/6
BRS-930	Wide Coffee Pot & Pitcher Brush	Pinned	Each	1/6
BRS-935	Narrow Top Coffee Pot Brush	Pinned	Each	1/18

Measurement is the "usable" length of the brush



### BAR MAID® GLASS WASHER BRUSH SETS

ITEM	DESCRIPTION	TYPE	UOM	CASE
BRS-1722	Replacement Brush Set Includes (4) 6" Standard Brushes & (1) 7-1/2" For Taller Glassware Brush, Fits all Bar Maid models	Pinned	Box	1/6
BRS-1720SL	Replacement Universal Brush Set Includes (4) 6" Standard Brushes & (1) 6-3/4" Brush for Slightly Taller Glassware	Slotted	Box	1/6



BRS-1722



**DISINFECT**

**SANITIZE**

**DEODERIZE**



**BAR MAID® SANI-MAID DISINFECTANT, SANITIZER AND DEODORANT TABLETS**

A multi-use germicidal disinfectant, sanitizer and true deodorant.

- ◆ Dissolve instantly in warm or cold water
- ◆ Use one tablet per gallon for 200 ppm or two tablets per gallon for 400 ppm
- ◆ Does not harm any surface not harmed by water.
- ◆ Controls odors
- ◆ No chlorine taste or odor
- ◆ 200 tablets per bottle

ITEM	DESCRIPTION	UOM	CASE
DIS-207	Quaternary Sanitizer/Disinfectant Tablets, 4 Bottles	Box	1/12

**GLASS CLEANERS**



DIS-207



DET-1200



**BAR MAID® LOSUDS LIQUID CONCENTRATE**

Liquid glassware detergent for electric and manual glass washers effectively removes stains, residue, and contaminants without leaving streaks or spots. Excellent in all types of water and easy on hands.

- ◆ Cuts grease and oils, leaving glassware spotless
- ◆ Save money – 1/4 ounce to 3 gallons of water is all you need for sparkling clean glassware
- ◆ 128 applications per 1 quart bottle

ITEM	DESCRIPTION	UOM	CASE
DET-1200	LoSUDS Concentrate, (12) 1 Qt Bottles Per Case	Each	12

**BAR MAID® SANITIZER STRIPS**

Ensure your dishes and glassware are properly sanitized.

- ◆ Convenient dispenser saves unused strips from damage
- ◆ Approximately 100 strips per dispenser
- ◆ 12 dispensers per display box

ITEM	DESCRIPTION	UOM	CASE
DIS-202	Quaternary Strips in Roll	Box	1/100
DIS-302	Chlorine Strips in Roll	Box	1/50
DIS-303	Chlorine Strips in Vial	Each	1/500



DIS-302



DIS-202



DIS-303

**BAR MAID® PH TEST STRIPS**

Monitor water quality in food service applications. Simply dip pH test strip in a solution and compare to color chart on package.

- ◆ Convenient dispenser saves unused strips from damage
- ◆ 3 – 5.5 range for food service applications
- ◆ Approximately 100 per dispenser

ITEM	DESCRIPTION	UOM	CASE
DIS-402	pH Test Strips in Dispenser	Each	1/12



DIS-402





# ONE EMPLOYEE CAN POLISH HUNDREDS OF GLASSES PER HOUR

## GLASS POLISHERS



UP TO  
**350**  
PIECES PER HOUR



GP-100

**2 YEAR WARRANTY**

**On-demand solutions**

*On-demand glassware polishing solution that saves on labor, replacement costs, and injury claims.*

- ◆ Efficient: warm air flow dries just-washed glassware while polishing
- ◆ Sanitary: reduces unhygienic handling & lint-free
- ◆ Safe: low risk of breakage, reducing injury claims and glassware replacement costs
- ◆ Portable: lightweight and compact footprint with built-in handles for polishing options anywhere
- ◆ Polishing heads are soft and absorbent, removable, and washable



### BAR MAID® GLASS POLISHER

- ◆ High-volume on-demand polishing
- ◆ 5 standard size polishing heads
- ◆ Ideal for caterers, restaurants, event halls, and more

ITEM	OVERALL DIMENSIONS L" x D" x H" (mm)	POWER	PLUG	SHIP WEIGHT
GP-100	12.8 x 11.8 x 19.7 (325 x 300 x 500)	120V-50/60Hz, 1350W, 12.5 A	NEMA 5-15P	38 lbs (17.3 kgs)



ITEM	DESCRIPTION	UOM	CASE
GP-100	Glass Polisher with 5 Polishing Heads	Each	1



UP TO  
**290**  
PIECES PER HOUR



GP-3MINI



### BAR MAID® COMPACT GLASS POLISHERS

- ◆ 3 standard size polishing heads
- ◆ Ideal for hotels, bars, tasting rooms, casinos, and more

ITEM	OVERALL DIMENSIONS L" x D" x H" (mm)	POWER	PLUG	SHIP WEIGHT
GP-3MINI	10.63 x 9.25 x 20.9 (270 x 235 x 530)	110V-50/60 Hz, 1300W, 12.5 A	NEMA 5-15P	33 lbs (14.8 kgs)
GP-3MINI-CE		220V-50/60 Hz	CEE 7/7	



ITEM	DESCRIPTION	UOM	CASE
GP-3MINI	Glass Polisher with 3 Polishing Heads, 110V	Each	1
GP-3MINI-CE	Glass Polisher with 3 Polishing Heads, 220-240V	Each	1

- ✓ **HIGH-VOLUME**
- ✓ **LOW-RISK**
- ✓ **CONSISTENTLY CLEAR RESULTS**



**BAR MAID® GLASS POLISHER BRUSHES**

◆ Soft, absorbent, and washable

ITEM	DESCRIPTION	TYPE	UOM	CASE
GP-554	5" Polishing Head for Champagne Flutes	Slotted	Each	1/10
PH-5C	6" Polishing Head for Center Slot	Slotted	Each	1/3
PH-1	7" Standard Polishing Head	Slotted	Each	1
PH-3S	3-Pc Set Polishing Heads for GP-3MINI	Slotted	Set	1/5
PH-5S	5-Pc Set Polishing Heads for GP-100	Slotted	Set	1/3
GP-552-LB	5-Pc Set: (1) 7" Standard & (4) 8" Carafe, Long Polishing Heads for GP-100	Slotted	Set	1/3
GP-533-LB	Long Blower Tube, Use With GP-552-LB, for GP-100	Slotted	Each	1

Measurement is the "usable" length of the brush



**GLASS POLISHER BRUSHES**



GP-554



PH-3S



PH-1



PH-5S



PH-5C

**BAR MAID® GLASS POLISHING WAND**

- ◆ Flexible wand tip contours to shape of glass for reduced stress and gentle polishing
- ◆ Included cloth sleeve is lint-free and washable

ITEM	DESCRIPTION	UOM	CASE
GP-1M	Manual Polishing Wand	Each	1/35
GP-3MC	Polishing Wand Replacement Pack Cloths, 3 per Pack	Pack	1/6



GP-1M



GP-3MC

Lint-free shine ✨





# A WIN FOR THE HOUSE AND THE PLAYERS

## GAME CHIP CLEANERS

**NEW**

**60+**  
PIECES PER MINUTE



CP-3000-D-CC

**NEW**

**140+**  
PIECES PER MINUTE



CP-7000-CC

**NEW**

**160+**  
PIECES PER MINUTE



CP-7000-S-CC

### BAR MAID® CHIP CHAMPION™

Process thousands of game chips, dice, and tiles through the Chip Champion™ every hour for clean, germ-free dealing and playing.

- ◆ Step 1 - Sanitize with quaternary tablet sanitizer solution (sold separately)
- ◆ Step 2 - Process through the Chip Champion to scrub and dry
- ◆ Fast ROI: gain significant speed, efficiency, and cost savings, ensuring an enjoyable gaming experience
- ◆ Sanitary: reduces unhygienic handling, and UV-C light kills contaminants for safe service
- ◆ Portable: compact footprint fits most work tables for portable polishing options

ITEM	DESCRIPTION	UOM	CASE
CP-3000-D-CC	Game Chip Polisher 120V, 3,000-4,000 pcs/hour	Each	1
CP-7000-CC	Game Chip Polisher 120V, 7,000-9,000 pcs/hour	Each	1
CP-7000-S-CC	Game Chip Polisher 120V, 10,000 pcs/hour, With Feeder	Each	1
CP-REFILL	Granulate Refill, 12-1/2 lb Bag	Each	1



Clean and ready for game-play

ETL Intertek CP-SERIES

New Item





- ✓ **GAIN SPEED & COST SAVINGS**
- ✓ **MORE SANITARY**
- ✓ **MAINTAIN CUSTOMER CONFIDENCE**



**BAR MAID® FLATWARE POLISHERS**

*Effectively remove spots, streaks, and bacteria from flatware for a sparkling clean and eliminate doubts about the cleanliness of your establishment.*

- ◆ Efficient: polish flatware directly from the dishwasher for optimal clean & dry shine
- ◆ Fast ROI: gain significant speed, efficiency, and cost savings over hand-polishing
- ◆ Sanitary: reduces unhygienic handling, and UV-C light kills contaminants for safe service
- ◆ Portable: compact footprint fits most work tables for portable polishing options
- ◆ Spotless Reputation: maintain customer confidence in a clean establishment with spot-free, streak-free, bacteria-free flatware

ITEM	DESCRIPTION	UOM	CASE
CP-3000-D	Flatware Polisher 120V, 3,000-pcs/hour, 22-1/2"L x 20-1/2"W x 17"H	Each	1
CP-7000	Flatware Polisher 120V, 7,000-pcs/hour, 25-1/2"L x 24-1/2"W x 19"H	Each	1
CP-REFILL	Flatware Polisher Granulate Refill, 12-1/2 lb Bag	Each	1



**FLATWARE POLISHERS**



CP-3000-D



CP-7000



CP-SERIES



Granulate

CP-REFILL



# COMMERCIAL MANUAL CAN OPENERS



Portable clamp included



Removable blade



Securely clamps to work surface



Easy operation

## PREMIUM MANUAL CAN OPENERS

Our premium European-made heavy-duty stainless steel can opener is fitted with a removable clamp, ideal for on-the-go operations that require flexibility. The rust-resistant stainless steel gear and blade effectively opens various can sizes up to #10.

- ◆ Includes base, blade, gear and installation kit for mounting on wooden or stainless steel work tables
- ◆ Easily disassembles for cleaning/sanitizing
- ◆ Heavy-duty stainless steel construction
- ◆ Rigid universal mounting base for screw-down or clamp-on installation with wooden or stainless steel work tables
- ◆ 19" (482mm) long bar accommodates various sizes of cans up to 16" (406mm) tall
- ◆ Quick change dual-sided tempered knife blade and stainless steel gear

ITEM	OVERALL DIMENSIONS L" X D" X H" (mm)	SHIP WEIGHT
CO-3N	8-7/16 x 4 x 25-1/2 (214 x 102 x 648)	5.6 lbs (2.5 kg)

ITEM	DESCRIPTION	UOM	CASE
CO-3N	Stainless Steel Base, NSF	Each	1/12
CO-3N-B	1-Pc S/S Replacement Blade for CO-3N	Each	1
CO-3G	1-Pc S/S Replacement Gear Set for CO-3N	Each	1



CO-3N-B



CO-3G



CO-3N portable clamp



CO-3N

## STANDARD #1 MANUAL CAN OPENER

The go-to industry standard, steel body can opener, made for heavy usage kitchen environments that require processing of up to 50 cans a day. Opens various can sizes up to #10.

- ◆ Includes base, blade, gear and installation kit
- ◆ Rigid universal mounting base for screw-down to a wooden or stainless steel work table
- ◆ 13" (330mm) long bar accommodates any size can up to 10" (254mm) tall
- ◆ Extra-durable dual-sided knife blade and gear are interchangeable with most other can opener brands



CO-1



Securely clamps to work surface

ITEM	DESCRIPTION	UOM	CASE
CO-1	Cast Iron Body	Set	1
CO-1B	2-Pc Replacement Blade Set for CO-1	Set	24/288
CO-1G	1-Pc Replacement Gear Set for CO-1	Each	12/144



CO-1B



CO-1G

### HEAVY-DUTY CAST IRON MEAT GRINDER

The Winco manual meat grinder is an economical and reliable tool for all your meat processing needs. With interchangeable plates, make your own sausages, burgers and more.

- ◆ Large 3" by 4" (76 x 102 mm) hopper opening
- ◆ Heavy-duty cast iron construction with food-safe tinned coating
- ◆ Durable cast iron grinding knife
- ◆ Easy to crank handle with heavy-duty nylon bearing for long life
- ◆ Two (2) grinding plates: medium grind 3/16" (4mm), coarse grind 5/16" (8mm)
- ◆ Sausage stuffing kit with three (3) stuffing tubes: 9/16" (14 mm), 3/4" (19 mm), & 15/16" (24 mm), stuffing star, and flange
- ◆ Clamp base easily secures to countertop or work surface

ITEM	OVERALL DIMENSIONS L" X D" X H" (mm)	SHIP WEIGHT
MG-10	10 x 4-1/4 x 8-7/8 (254 x 108 x 226)	5.5 lbs (2.5 kg)



ITEM	DESCRIPTION	UOM	CASE
MG-10	Meat Grinder with Clamp Base	Set	1/10
MG-1018	Grinder Plate, 1/8" (3mm)	Each	100
MG-10316	Grinder Plate, 3/16" (4mm)	Each	100
MG-1014	Grinder Plate, 1/4" (6mm)	Each	100
MG-10516	Grinder Plate, 5/16" (8mm)	Each	100
MG-1038	Grinder Plate, 3/8" (10mm)	Each	100
MG-10K	Grinder Knife	Each	100
MG-10SSK	Sausage Stuffing Kit 1 Flange & 3 Tubes	Each	100

## KATTEX™ MEAT GRINDER



MG-10



### HEAVY-DUTY BURGER PATTY PRESS WITH INTERCHANGEABLE PLATES

Effortlessly make uniform burgers with this time-saving portion control molding press. Interchangeable plates make either 4" (1/4 lb) or 5" (1/2 lb) round patties.

- ◆ Heavy-duty anodized aluminum construction with stainless steel press bowls and press plates
- ◆ Manual single-lever operation for quick, easy press-and-release uniform patties
- ◆ Interchangeable 4" (100mm) and 5" (130mm) press plates & bowls; removal tool included
- ◆ Built-in patty paper holder, and includes 500 each of both 4" and 5" diameter patty paper

ITEM	OVERALL DIMENSIONS L" X D" X H" (mm)	SHIP WEIGHT
HBP-3	10 x 9-1/2 x 12-3/4 (254 x 241 x 324)	18.1 lbs (8.2 kg)



ITEM	DESCRIPTION	UOM	CASE
HBP-3	Hamburger Patty Press	Set	1
HBP-PR100	4" (100mm) Perforated Round Patty Paper, Case of 5000	Case	1/10
HBP-PR130	5" (130mm) Perforated Round Patty Paper, Case of 5000	Case	1/10



## KATTEX™ BURGER PATTY PRESS



HBP-3



# KATTEX™ FRUIT & VEGETABLE SLICER



FVS-1

### QUICK-SLICE FRUIT & VEGETABLE SLICER

Save on time and labor - simply place produce in the holder to turn out uniform slices in seconds.

- ◆ Aluminum construction with 9-1/4" stainless steel adjustable blade
- ◆ Adjustable thickness gauge - select from 1/16" (1mm) up to 1/2" (12mm) thick slicing
- ◆ Accommodates fruits/vegetables up to 4" diameter and 5-1/2" in length
- ◆ Mounting bracket included - mounts directly to work surface, or on the cutting board mount (CBM-1218)

ITEM	OVERALL DIMENSIONS L" X D" X H" (mm)	SHIP WEIGHT
FVS-1	16 x 8-11/16 x 16 (406 x 220 x 406)	12.1 lbs (5.5 kgs)

ITEM	DESCRIPTION	UOM	CASE
FVS-1	21"L x 10-3/4"W x 16"H	Each	1/2
FVS-1B	2-Pc Replacement Blades	Set	1/10
FVS-1SB	Replacement Shaft and Blade Turntable Assembly	Each	1/6

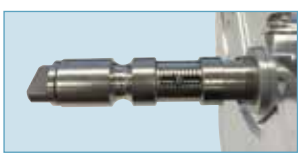

Thickness gauge



Replacement blade



FVS-1 mounted and ready

### CUTTING BOARD MOUNT FOR FRUIT & VEGETABLE SLICER

Add portability to Kattex FVS-1 Slicer with this customized STATIKBOARD™ cutting board mount. The molded-through, non-slip feet prevent slipping & sliding, even on wet countertops, and the fully-rubberized hook provides easy storage.

- ◆ Board size: 12" (30.5mm) x 18" (45.7mm) x 1/2" (1.3mm)
- ◆ Built-in hook for easy transport and hygienic storage
- ◆ Dishwasher safe tough durable copolymer board construction
- ◆ Stainless steel flush mounting hardware included (mounting bracket sold separately or comes with FVS-1)

ITEM	DESCRIPTION	UOM	CASE
CBM-1218	Cutting Board Mount for FVS-1	Each	1



**STATIKboard™**  
Patented original design

NSF CBM-1218

New Item



**PRECISE-SLICE TOMATO SLICERS**

Razor sharp stainless steel blades cradle delicate tomatoes, while smoothly and swiftly producing clean, uniform slices.

- ◆ Cast aluminum frame with stainless steel blades for even, clean cuts; blades are replaceable
- ◆ Ergonomic vertical handle provides smooth, effortless slicing
- ◆ Cuts 2 dozen tomatoes into 3/16" or 1/4" thick slices in only 1 minute!
- ◆ HDPE slicing surface for safe & durable food processing
- ◆ Rubber non-slip feet ensure maximum stability
- ◆ Slicers come standard with a stop/hold bracket

ITEM	OVERALL DIMENSIONS L" X D" X H" (mm)	SHIP WEIGHT
TTS-188	16-1/2 x 8-1/4 x 9-1/2 (420 x 210 x 240)	9.3 lbs (4.2 kgs)
TTS-188S		
TTS-250		
TTS-250S		

ITEM	DESCRIPTION	UOM	CASE
TTS-188	3/16" Cut w/Straight Blade	Set	1/4
TTS-188S	3/16" Cut w/Serrated Blade	Set	1/4
TTS-250	1/4" Cut w/Straight Blade	Set	1/4
TTS-250S	1/4" Cut w/Serrated Blade	Set	1/4

**TOMATO SLICER ACCESSORIES**

ITEM	DESCRIPTION	UOM	CASE
TTS-188-B	3/16" Straight Blade Assembly for TTS-188	Set	1/12
TTS-188S-B	3/16" Serrated Blade Assembly for TTS-188	Set	1/12
TTS-250-B	1/4" Straight Blade Assembly for TTS-250	Set	1/12
TTS-250S-B	1/4" Serrated Blade Assembly for TTS-250	Set	1/12
KAT-FT	4-Pc Replacement Feet Set	Set	1
KAT-WR	Dual-End Wrench	Each	1/25

**KATTEX™ TOMATO SLICERS**

Includes blade replacement wrench



TTS-188



TTS-188-B

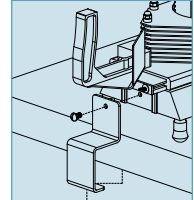

Stop/hold bracket included

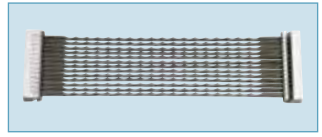

TTS-188S-B



KAT-WR

TTS-SERIES NSF

**QUICK-SLICE CHEESE SLICERS**

Make light work of slicing a variety of semi-soft cheeses, with uniform, consistent results. Ideal for portion control and faster food prep.

- ◆ Cast aluminum construction with stainless steel wires
- ◆ Cutting area accommodates 1/3 of a 5 lb cheese block
- ◆ Cut 3/8" or 3/4" cheese sticks, cubes or slices
- ◆ Cleaning brush included

ITEM	OVERALL DIMENSIONS L" X D" X H" (mm)	SHIP WEIGHT
TCT-375	13 1/4 x 6 1/4 x 4 1/2 (335 x 170 x 115)	4.2 lbs (1.9 kgs)
TCT-750		

ITEM	DESCRIPTION	UOM	CASE
TCT-375	3/8" Cut	Each	1/4
TCT-750	3/4" Cut	Each	1/4

**CHEESE SLICER ACCESSORIES**

ITEM	DESCRIPTION	UOM	CASE
TCT-375B	Replacement Bow for TCT-375	Set	1/10
TCT-750B	Replacement Bow for TCT-750	Set	1/10



TCT-375B  
3/8" wide cuts



TCT-750B  
3/4" wide cuts



Uniformly slice cheese blocks

**KATTEX™ CHEESE SLICERS**



TCT-375



TCT-750

TCT-SERIES NSF

# KATTEX™ ONION SLICERS



OS-250

Includes leg-mounting wrench



KAT-WR



OS-250B  
Blade set assembly

NSF OS-SERIES

## QUICK-SLICE ONION/FRUIT/VEGETABLE SLICERS

Quickly produce evenly sliced coins of fruits and vegetables in a single smooth stroke.

- ◆ Aluminum construction with stainless steel blades
- ◆ Unique lever-handle allows for quick and easy operation
- ◆ Sturdy base with non-skid feet
- ◆ Two blades included can be stacked to create a finer cut
- ◆ 4-1/2" x 3-3/4" cutting area

ITEM	OVERALL DIMENSIONS L" X D" X H" (mm)	SHIP WEIGHT
OS-188	19 x 10 x 19 (483x 254 x 483)	17.8 lbs (8.1 kgs)
OS-250		

ITEM	DESCRIPTION	UOM	CASE
OS-188	3/16" Cut	Each	1/2
OS-250	1/4" Cut	Each	1/2

## ONION/FRUIT/VEGETABLE SLICER ACCESSORIES

ITEM	DESCRIPTION	UOM	CASE
OS-188B	3/16" Blade Set Assembly for OS-series, 2-Pcs/Set	Set	1/10
OS-250B	1/4" Blade Set Assembly for OS-series, 2-Pcs/Set	Set	1/10
KAT-FT	4-Pc Replacement Feet Set	Set	1
KAT-BS-OT	4-Pc Replacement Bushings	Set	1
KAT-WR	Dual-End Wrench	Each	1/25

# KATTEX™ LETTUCE CUTTER



TLC-1

Includes leg-mounting wrench

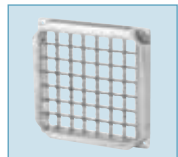

TLC-1-B



KAT-WR

NSF TLC-SERIES

## QUICK-SLICE LETTUCE CUTTER

Cut multiple heads of crisp, fresh lettuce in seconds. The interlocking scalloped, pretensioned blades are sized to cut 1 inch squares of cored lettuce, without bruising or browning.

- ◆ Aluminum frame with easy-grip handle
- ◆ Stainless steel blade with 49 square cuts
- ◆ Cuts lettuce into 1" x 1" slices in less than 1 minute
- ◆ Rubber feet prevent slipping/scratching on work surface
- ◆ 7" x 7" cutting area

ITEM	OVERALL DIMENSIONS L" X D" X H" (mm)	SHIP WEIGHT
TLC-1	13 x 18 x 20 (330 x 457 x 508)	17.8lbs (8.1 kgs)

ITEM	DESCRIPTION	UOM	CASE
TLC-1	1" x 1" Cut	Each	1/2

## LETTUCE CUTTER ACCESSORIES

ITEM	DESCRIPTION	UOM	CASE
TLC-1-B	Replacement Blade for TLC-1	Each	1/10
KAT-FT	4-Pc Replacement Feet Set	Set	1
KAT-BS-OT	4-Pc Replacement Bushings	Set	1
KAT-WR	Dual-End Wrench	Each	1/25

## QUICK-SLICE CHOPPERS/DICERS

For perfectly diced onions and tomatoes, and cucumbers too, turn to the Kattex Chopper/Dicer.

- ◆ Cast aluminum construction with stainless steel blades
- ◆ Sturdy base with non-skid feet
- ◆ 3-3/8" x 3-3/8" cutting area

ITEM	OVERALL DIMENSIONS L" X D" X H" (mm)	SHIP WEIGHT
HCD-250	7-15/16 x 7-15/16 x 18-1/2 (200 x 200 x 470)	7.1 lbs (3.2 kgs)
HCD-375		
HCD-500		

ITEM	DESCRIPTION	UOM	CASE
HCD-250	1/4" Cut	Each	1/4
HCD-375	3/8" Cut	Each	1/4
HCD-500	1/2" Cut	Each	1/4

### CHOPPER/DICER ACCESSORIES

ITEM	DESCRIPTION	UOM	CASE
HCD-250BK	1/4" Replacement Blade & Block for HCD-series	Set	1/10
HCD-375BK	3/8" Replacement Blade & Block for HCD-series	Set	1/10
HCD-500BK	1/2" Replacement Blade & Block for HCD-series	Set	1/10
HCD-BR	2-Pc Black Rubber Ring	Set	1/50
KAT-FT	4-Pc Replacement Feet Set	Set	1
KAT-BS-FH	4-Pc Replacement Bushings	Set	1

## KATTEX™ CHOPPERS/DICERS



HCD-250

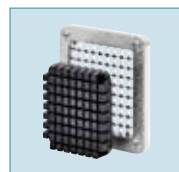

Replacement blade and block

HCD-SERIES 

## QUICK-SLICE FRUIT WEDGE SLICERS

Get quick and uniform wedges of fruit with a push of the handle. Ideal for coring and sectioning apples, lemons, limes, oranges, and tomatoes.

- ◆ Aluminum construction with sharp stainless steel blades that minimize squeezing and bruising
- ◆ Sturdy base with non-skid feet
- ◆ 3-1/2" diameter cutting area

ITEM	OVERALL DIMENSIONS L" X D" X H" (mm)	SHIP WEIGHT
FWS-6	7-15/16 x 7-15/16 x 18-1/2 (200 x 200 x 470)	5.7 lbs (2.6 kgs)
FWS-8		

ITEM	DESCRIPTION	UOM	CASE
FWS-6	6-Wedge	Each	1/4
FWS-8	8-Wedge	Each	1/4

## KATTEX™ FRUIT WEDGE SLICERS



FWS-8



FWS-6BC  
Apple corer blade



FWS-6BK  
Replacement wedger and blade for citrus fruits

FWS-SERIES 

### FRUIT WEDGE SLICER ACCESSORIES

ITEM	DESCRIPTION	UOM	CASE
FWS-6BK	6-Section Wedger & Blade Replacement	Set	1/10
FWS-8BK	8-Section Wedger & Blade Replacement	Set	1/10
FWS-6BC	6-Slice Apple Corer Blade	Each	10
FWS-8BC	8-Slice Apple Corer Blade	Each	10
KAT-FT	4-Pc Replacement Feet Set	Set	1
KAT-BS-FH	4-Pc Replacement Bushings	Set	1

# KATTEX™

## FRENCH FRY CUTTERS - HEAVY-DUTY



HFC-375



Wall mounted with HFC-BK

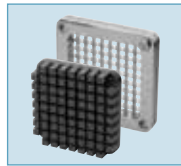

Replacement block and cut blade assembly

**NSF** HFC-SERIES



### QUICK-SLICE FRENCH FRY CUTTERS - HEAVY-DUTY

Add speed and efficiency to slicing potatoes, and fruits & vegetables. The durable cast iron body construction with stainless steel components ensures the cutter will withstand years of high-volume, heavy-duty use.

- ◆ Press down on the short throw handle with comfortable grip for uniform cuts in one smooth stroke
- ◆ Extremely durable cast iron body with stainless steel components
- ◆ Affix to counter or wall mount; wall bracket sold separately
- ◆ 3-3/8" x 3-3/8" cutting area
- ◆ Accessories to modify cut sizes and styles sold separately

ITEM	OVERALL DIMENSIONS L" X D" X H" (mm)	SHIP WEIGHT
HFC-250	8 x 14 x 16 <sup>3</sup> / <sub>4</sub> (203 x 356 x 426)	12.7 lbs (5.8 kgs)
HFC-375		13.6 lbs (6.2 kgs)
HFC-500		13.3 lbs (6 kgs)

ITEM	DESCRIPTION	UOM	CASE
HFC-250	1/4" Cut	Set	1
HFC-375	3/8" Cut	Set	1
HFC-500	1/2" Cut	Set	1

### FRENCH FRY CUTTER ACCESSORIES

ITEM	DESCRIPTION	UOM	CASE
HFC-250R	1/4" Cut Replacement Blade	Set	1/48
HFC-375R	3/8" Cut Replacement Blade	Set	1/48
HFC-500R	1/2" Cut Replacement Blade	Set	1/48
HFC-250B	1/4" Cut Blade Assembly	Set	1/24
HFC-375B	3/8" Cut Blade Assembly	Set	1/24
HFC-500B	1/2" Cut Blade Assembly	Set	1/24
HFC-250K	Pusher Block for 1/4" and 1/2" Cut Blade	Each	1/24
HFC-375K	Pusher Block for 3/8" Cut Blade	Each	1/24
HFC-BK	Wall Bracket for HFC series	Each	1/12

## FRENCH FRY CUTTERS - MEDIUM-DUTY



FFC-375



FFC-250B

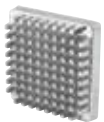

FFC-250K

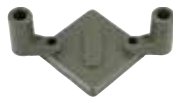

FFC-500P



FFC-6B



FFC-6K



### FRENCH FRY CUTTERS - MEDIUM-DUTY

- ◆ Made of heavy-duty cast iron and fitted with sharp stainless steel blades for even slicing
- ◆ Ergonomic handle for easy operation, and sturdy legs for stability on countertop/work surfaces

ITEM	OVERALL DIMENSIONS L" X D" X H" (mm)	SHIP WEIGHT
FFC-250	8 x 14 x 16- <sup>3</sup> / <sub>4</sub> (203 x 356 x 426)	11.6 lbs (5.3 kg)
FFC-375		
FFC-500		

ITEM	DESCRIPTION	UOM	CASE
FFC-250	1/4" Cut	Each	1
FFC-375	3/8" Cut	Each	1
FFC-500	1/2" Cut	Each	1

### MEDIUM-DUTY FRENCH FRY CUTTER ACCESSORIES

ITEM	DESCRIPTION	UOM	CASE
FFC-250B	Blade Assembly for FFC-250	Each	24
FFC-250K	Pusher Block for FFC-250	Each	24
FFC-375B	Blade Assembly for FFC-375	Each	24
FFC-375K	Pusher Block for FFC-375	Each	24
FFC-500B	Blade Assembly for FFC-500	Each	24
FFC-500K	Pusher Block for FFC-500	Each	24
FFC-6B	6 Wedge Cut Blade Assembly	Each	1/24
FFC-6K	Pusher Block for FFC-6B	Each	1/24
FFC-8B	8 Wedge Cut Blade Assembly	Each	1/24
FFC-8K	Pusher Block for FFC-8B	Each	1/24
FFC-500P	Pusher Support for FFC-Series	Each	12
HFC-BK	Wall Bracket	Each	1/12



# winco<sup>®</sup> BENCH MARK **USA**<sup>™</sup>

*Concession Equipment and Supplies*

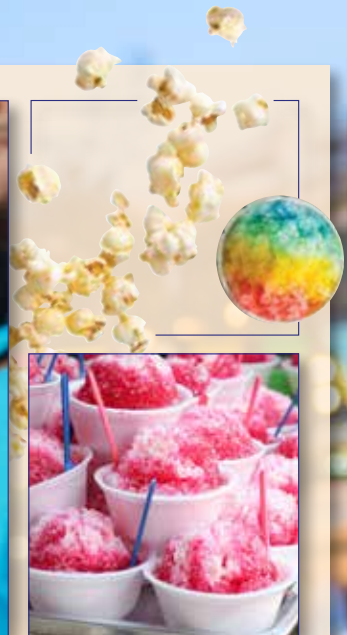

The product & package images shown are for illustration purposes and may differ from actual. Products and specifications subject to change without notice.



POPCORN MACHINES



11040, 11060, & 11080



30010



STREET VENDOR™ POPCORN MACHINES

Take a walk down memory lane with "Street Vendor". Styled after old-time boardwalks of Coney Island and Palisades Park, they remind of an era when vendors sold popcorn on street corners all across America.

- ◆ Easy to use, simple two-switch operation
- ◆ Built-in heated warming deck and warmer light (bulb not included)
- ◆ Old maid drawer catches unpopped kernels
- ◆ Stainless steel food-zone
- ◆ Thick 20 mil non-stick coated popping kettle
- ◆ Tempered glass panels on front and side
- ◆ Clear plexiglass doors at rear

ITEM	OVERALL DIMENSIONS L" X D" X H" (mm)	POWER	PLUG	SHIP WEIGHT
11040	21 x 18 x 34 (534 x 457 x 864)	120V~60Hz, 1040W, 8.6A	NEMA 5-15P	62 lbs (28.1 kgs)
11060		120V~60Hz, 1240W, 10.3A		64 lbs (29 kgs)
11080		120V~60Hz, 1490W, 12.4A		66 lbs (30 kgs)

ITEM	DESCRIPTION	UOM	CASE
11040	4 oz Kettle	Set	1
11060	6 oz Kettle	Set	1
11080	8 oz Kettle	Set	1



Catch tray



Simple two-switch operation



Old maid drawer catches unpopped kernels

STREET VENDOR™ CART

- ◆ Spoked wheels and sturdy handle for easy transport
- ◆ Merchandising side shelf
- ◆ Operator-side storage & work space

ITEM	DESCRIPTION	UOM	CASE
30010	Cart/Trolley for Street Vendor Popcorn Machines 38" w x 23" d x 33" h	Set	1



Convenient storage compartment on service side

The product & package images shown are for illustration purposes and may differ from actual.



**METROPOLITAN™ POPCORN MACHINES**

The design of "Metropolitan", inspired by the Art Deco style of the 1930's, brings a unique, attractive appeal.

- ◆ Easy to use, simple two-switch operation
- ◆ Built-in heated warming deck and warmer light (bulb not included)
- ◆ Old maid drawer catches unpopped kernels
- ◆ Stainless steel food-zone
- ◆ Thick 20 mil non-stick coated popping kettle
- ◆ Tempered glass panels on front and side
- ◆ Clear plexiglass doors at rear

ITEM	OVERALL DIMENSIONS L" X D" X H" (mm)	POWER	PLUG	SHIP WEIGHT
11045	18-½ x 14 x 30 (470 x 356 x 762)	120V-60Hz, 1040W, 8.6A	NEMA 5-15P	51 lbs (23.1 kgs)
11065		120V-60Hz, 1240W, 10.3A		52 lbs (23.6 kgs)

ITEM	DESCRIPTION	UOM	CASE
11045	4 oz Kettle	Set	1
11065	6 oz Kettle	Set	1

**BENCHMARK USA™**  
**POPCORN MACHINES**



Catch tray



Simple two-switch operation



Old maid drawer catches unpopped kernels

**METROPOLITAN™ PEDESTAL BASE**

- ◆ 3" swivel casters for easy mobility
- ◆ Storage compartment with interior shelf & door

ITEM	DESCRIPTION	UOM	CASE
30050	Pedestal Base for Metropolitan Popcorn Machines 18-5/8"L x 14-1/4"D x 32-7/8"H	Set	1

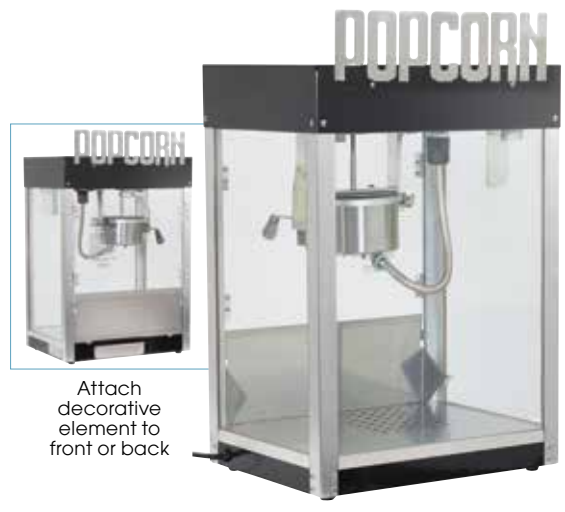

Attach decorative element to front or back

CE ETL US ETL  
Intertek Intertek  
11045 & 11065



Textured storage door handle

Convenient storage compartment on service side



30050

The product & package images shown are for illustration purposes and may differ from actual.



POPCORN MACHINES



11048 & 11068



30080

PREMIERE™ POPCORN MACHINES

"Premiere" flavorful popped corn in big-screen style.

- ◆ Easy to use, simple two-switch operation
- ◆ Warmer light (bulb not included)
- ◆ Old-maid drawer catches unpopped kernels
- ◆ Stainless steel food-zone for easy cleaning
- ◆ Thick 20 mil non-stick coated popping kettle
- ◆ Tempered glass panels on front and side
- ◆ Clear plexiglass doors at rear

ITEM	OVERALL DIMENSIONS L" X D" X H" (mm)	POWER	PLUG	SHIP WEIGHT
11048	18-1/2 x 14 x 26-1/2 (470 x 356 x 673)	120V-60Hz, 940W, 7.8A	NEMA 5-15P	49 lbs (22.3 kgs)
11068		120V-60Hz, 1140W, 9.5A		50 lbs (22.7 kgs)

ITEM	DESCRIPTION	UOM	CASE
11048	4 oz Kettle	Set	1
11068	6 oz Kettle	Set	1



Catch tray



Simple two-switch operation



Old maid drawer catches unpopped kernels

PREMIERE™ PEDESTAL BASE

- ◆ 3" swivel casters for easy mobility
- ◆ Storage compartment with interior shelf

ITEM	DESCRIPTION	UOM	CASE
30080	Pedestal Base for Premiere Popcorn Machines 18-5/8"L x 14-1/4"D x 32-7/8"H	Set	1



Convenient storage compartment on service side

The product & package images shown are for illustration purposes and may differ from actual.



## SILVER SCREEN™ POPCORN MACHINES

"Silver Screen" is simple in looking and is technically savvy. A separate cabinet thermostat and temperature indicator accurately controls the heat, ensuring that your popcorn is always at the perfect serving temperature.

- ◆ Stainless steel cabinet and food-zone
- ◆ Thermostatically controlled serving temperature
- ◆ Four-switch configuration allows for any operating situation
- ◆ Built-in warmer light (bulb not included)
- ◆ Old maid drawer catches unpopped kernels
- ◆ Superior performance hard-coat anodized, high thermal popping kettle

ITEM	OVERALL DIMENSIONS L" X D" X H" (mm)	POWER	PLUG	SHIP WEIGHT
11087	20 x 17 x 30 (508 x 432 x 762)	120V-60Hz, 1490W, 12.4A	NEMA 5-15P	60 lb (27.2 kgs)
11147	24 x 19 x 36 (610 x 483 x 915)	120V-60Hz, 1740W, 14.5A	NEMA 5-15P NEMA 5-20P (Canada)	95 lb (43.1 kgs)

ITEM	DESCRIPTION	UOM	CASE
11087	8 oz Kettle	Set	1
11147	14 oz Kettle	Set	1

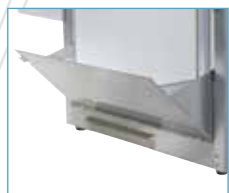

Catch tray



Four-switch operation



Old maid drawer catches unpopped kernels

# BENCHMARK USA™

## POPCORN MACHINES



11087



11147



11087 & 11147

## SILVER SCREEN™ PEDESTAL BASE

- ◆ 3" locking swivel casters for easy mobility
- ◆ Storage compartment with interior shelf

ITEM	DESCRIPTION	UOM	CASE
30087	8 oz Pedestal Base 20"W x 17"D x 33"H	Set	1
30147	14 oz Pedestal Base 24"W x 20"D x 33"H	Set	1



Plenty of storage space



Convenient storage compartment on service side



30087



POPCORN POPPERS



POP-8R

SHOWTIME!™ RED POPCORN MACHINE

It's ShowTime!™. Attractive, fun graphics and vibrant colors draw in popcorn profits.

- ◆ Removable non-stick 8 oz stainless steel kettle with twist-lock disconnect
- ◆ Independent illuminated control switches for Light, and Heat, Turn (motor)
- ◆ Front & side tempered glass panels
- ◆ Rear clear plexiglass door(s)
- ◆ Mirror polished stainless steel fold-out tray for easy access
- ◆ Built in warmer light
- ◆ Under-deck warming element
- ◆ Removable unpopped kernel tray

OVERALL DIMENSIONS L" X D" X H" (mm)	POWER	PLUG	SHIP WEIGHT
22 x 16-½ x 30 (559 x 420 x 762)	110V-60Hz, 1320W, 12A	NEMA 5-15P	55.1 lbs (25 kgs)



ITEM	DESCRIPTION	UOM	CASE
POP-8R	Red Popcorn Popper, Teflon® Coated Non-Stick Kettle	Set	1
POP8-P1	Replacement Non-stick Kettle	Each	1

Cart features same fun decal as POP-8R



POP-8RC

SHOWTIME!™ RED POPCORN MACHINE CART

- ◆ Allows the (POP-8R) Popcorn Machine to be portable
- ◆ Ideal where counterspace is limited
- ◆ 23-1/2" spoked wheels with inflatable rubber tires and sturdy handle for easy transport
- ◆ Convenient compartment on operator-side for storage and additional work space
- ◆ Overall Dimensions: 36-7/8"L x 22-3/4"D x 34-5/8"H



ITEM	DESCRIPTION	UOM	CASE
POP-8RC	Red Cart for POP-8R	Set	1
POP-8RC-D	Yellow "POPCORN" Decal	Each	1

Traditional-style decal option

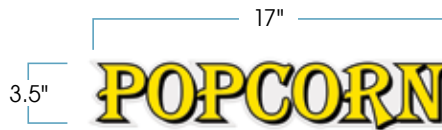

POP-8RC-D



Storage compartment

## SHOWTIME!™ BLACK POPCORN MACHINE

It's ShowTime!™. Attractive, fun graphics and vibrant colors draw in popcorn profits.

- ◆ Removable 8 oz stainless steel kettle with twist-lock disconnect
- ◆ Independent illuminated control switches for Light, Heat, Turn (motor), and Power
- ◆ Front & side tempered glass panels
- ◆ Rear clear plexiglass door(s)
- ◆ Mirror polished stainless steel fold-out tray for easy access
- ◆ Built in warmer light
- ◆ Under-deck warming element
- ◆ Removable unpopped kernel tray

OVERALL DIMENSIONS L" X D" X H" (mm)	POWER	PLUG	SHIP WEIGHT
17-¾ x 14-¾ x 23-½ (450 x 375 x 597)	110V-60Hz, 1150W, 9.5A	NEMA 5-15P	40.8 lbs (18.5 kgs)



ITEM	DESCRIPTION	UOM	CASE
POP-8B	Black Popcorn Popper	Set	1
POP8-P2	Replacement Kettle for POP-8B	Each	1



## POPCORN POPPERS



## ULTRA-BRIGHT "POPCORN" LED SIGN

Extremely bright and eye-catching in any environment, with simple, attractive, colorful graphics.

- ◆ 12V vivid LED back-light
- ◆ Durable extruded aluminum frame
- ◆ Hangs flat against the wall
- ◆ Environmentally friendly

ITEM	DESCRIPTION	UOM	CASE
92001	UltraBright Sign - Popcorn 16"W x 1-¼"D x 12"H	Each	5



## POPCORN SIGN



## POPCORN ACCESSORIES

ITEM	DESCRIPTION	UOM	CASE
MCP-4P	Measuring Cup Set, 4-pcs, Wire Handle, S/S	Set	12/48
PS-20	20 oz PC Scoop, Clear	Each	24/144
CR-890W	Bar Maid® Popcorn / Fry Scoop, White, PC	Each	1/12
42030	Aluminum Speed Scoop	Each	50
72301	Toz Pump	Each	1



72301



MCP-4P



PS-20

## POPCORN SUPPLIES



42030



CR-890W



The product & package images shown are for illustration purposes and may differ from actual.







POPCORN SUPPLIES



40004  
40006  
40008

UNPOPPED TO POPPED KERNEL CONVERSION					
UNPOPPED KERNELS			POPPED POPCORN		
1 oz	2 Tbsp	1/8 cup	32 oz	1 Qt	4 cups
4 oz		1/2 cup	128 oz	4 Qts	16 cups
6 oz		3/4 cup	192 oz	6 Qts	24 cups
8 oz		1 cup	256 oz	8 Qts	32 cups

POPCORN PORTION PACKS

ITEM	DESCRIPTION	UOM	CASE
40004	4oz - 24 packs/case	Case	1
40006	6oz - 24 packs/case	Case	1
40008	8oz - 24 packs/case	Case	1



40508

BULK UNPOPPED POPCORN KERNEL BAG

ITEM	DESCRIPTION	UOM	CASE
40507	12.5 lb Bag - 4 Bags/Case	Case	1



Popcorn kernels, oils, & flavorings!

POPCORN POPPING OILS

ITEM	DESCRIPTION	UOM	CASE
40012	Canola Oil - Gallon	Each	4
40011	Coconut Oil - Gallon	Each	1
40015	Coconut Oil - 50 lb Pail	Each	1



40015



40011



40012

POPCORN FLAVORINGS

ITEM	DESCRIPTION	UOM	CASE
40010	Buttery Salt - 35oz	Each	12
40017	Buttery Topping - 1 Gallon	Each	4
40021	Caramel Corn Glaze - 28oz	Each	12
40023	Cheddar Cheese Mix - 1 Gallon	Each	1



40010



40021



40017



40023

The product & package images shown are for illustration purposes and may differ from actual.



## POPCORN PAPER BAGS

ITEM	DESCRIPTION	DIMENSIONS	PCS/CASE	UOM	CASE
41001	1oz	2" x 3.5" x 8"	1,000	Case	1
41002	1.5oz	2.5" x 4" x 8.25"	1,000	Case	1
41003	2oz	5.25" x 12"	1,000	Case	1



## POPCORN SUPPLIES



4100X SERIES

## POPCORN BUTTER BAGS

ITEM	DESCRIPTION	DIMENSIONS	PCS/CASE	UOM	CASE
41232CS	32oz, Red	4.25"L x 2.5"W x 7"H	1,000	Case	1
41246CS	46oz, Orange	4.5"L x 2.5"W x 8.25"H	1,000	Case	1
41285CS	85oz, Blue	5"L x 3.5"W x 9.5"H	1,000	Case	1
41230CS	130oz, Green	6"L x 3.75"W x 10.5"H	500	Case	1
41270CS	170oz, Purple	7.5"L x 3.75"W x 10.75"H	500	Case	1



412XXCS SERIES

## POPCORN TAPERED SCOOP BOXES

ITEM	DESCRIPTION	DIMENSIONS	PCS/CASE	UOM	CASE
41044CS	0.75oz	3.5"W x 3.5"D x 6"H	500	Case	1
41047CS	1.25oz	3.5"W x 3.5"D x 7.5"H	500	Case	1
41048CS	2.5oz	4"W x 4"D x 8"H	500	Case	1



4104XCS SERIES

## CLOSED-TOP POPCORN BOXES

ITEM	DESCRIPTION	DIMENSIONS	PCS/CASE	UOM	CASE
41549CS	0.75oz	4"W x 2"D x 6.5"H	500	Case	1
41557CS	0.95oz	4.25"W x 2"D x 7"H	500	Case	1
41563CS	1.25oz	4.75"W x 2"D x 7.5"H	500	Case	1
41569CS	2.0oz	5.75"W x 2"D x 8.5"H	500	Case	1
41574CS	2.5oz	5.75"W x 2.5"D x 8.5"H	250	Case	1



415XXCS SERIES

## POPCORN TUBS

ITEM	DESCRIPTION	DIMENSIONS (W = AT TOP)	PCS/CASE	UOM	CASE
41432CS	32oz	4.5"W x 5.75"H	500	Case	1
41446CS	46oz	4.75"W x 7"H	600	Case	1
41485CS	85oz	7"W x 6.5"H	300	Case	1
41430CS	130oz	7.5"W x 8.25"H	300	Case	1
41470CS	170oz	7.5"W x 10"H	150	Case	1



414XXCS SERIES

The product & package images shown are for illustration purposes and may differ from actual.





COTTON CANDY MACHINES & SUPPLIES

60 cones per hour



CCM-28C  
Dome Cover  
sold separately

81011A

ZEPHYR™ COTTON CANDY MACHINE - PORTABLE

Easy to operate and produce up to 60 cones per hour, great for "on demand" service.

- ◆ Lightweight design with two handles for easy transport
- ◆ Stainless steel 20-1/2" dia bowl locks securely onto base
- ◆ Spinner head easily removes for cleaning
- ◆ Low vibration 1.2hp heavy-duty belt drive motor and replacement belt

ITEM	OVERALL DIMENSIONS L" X D" X H" (mm)	POWER	PLUG	SHIP WEIGHT
81011A	21 x 21 x 16 (534 x 534 x 406)	120V~60Hz, 1080W, 9A	NEMA 5-15P	28 lbs (12.7 kgs)

ITEM	DESCRIPTION	UOM	CASE
81011A	Zephyr Cotton Candy Machine	Set	1
CCM-28C	Clear Plastic Dome Cover 21"Dia x 14"H	Each	1/5

Includes floss sugar scooper



30090

ZEPHYR™ COTTON CANDY MACHINE CART

Stylish and convenient cotton candy trolley with ample work space and storage.

- ◆ Fits the Zephyr cotton candy machine
- ◆ Operator side storage shelf
- ◆ 3 cone holders integrated on side shelf

ITEM	DESCRIPTION	UOM	CASE
30090	Cart, 60" L x 24" D x 32" H	Set	1

Integrated cone holders



8200XCS-SERIES

COTTON CANDY SUGAR FLOSS

- ◆ 6 cartons/case

ITEM	DESCRIPTION	UOM	CASE
82001CS	Blue Raspberry 3.25lb carton	Case	1
82002CS	Bubblegum 3.25lb carton	Case	1
82003CS	Cherry 3.25lb carton	Case	1
82004CS	Grape 3.25lb carton	Case	1
82005CS	Pink Vanilla 3.25lb carton	Case	1
82006CS	Strawberry 3.25lb carton	Case	1



83005

COTTON CANDY PAPER CONES

ITEM	DESCRIPTION	UOM	CASE
83005	1,000 Cones/Pack	Pack	1



83001CS

COTTON CANDY POLY BAGS

ITEM	DESCRIPTION	UOM	CASE
83001CS	Poly Bags -1,000 Bags/Case	Case	1

The product & package images shown are for illustration purposes and may differ from actual.



## SHOWTIME!™ COTTON CANDY MACHINES

It's ShowTime!™. Attractive, fun graphics and vibrant colors draw in cotton candy profits.

- ◆ Simple, easy-to-use controls; makes 120 cones per hour
- ◆ Stainless steel 20-1/2" dia bowl locks securely onto base
- ◆ Large capacity built-in stainless steel supply drawer
- ◆ Spinner head holds 4oz of sugar and releases floss vertically, which prevents clogging
- ◆ Low vibration 1.5hp heavy-duty belt drive motor and two (2) replacement belts
- ◆ Easy access to voltage meter and fuse for use with generators and power supplies

## COTTON CANDY MACHINES



CCM-28C  
Dome Cover  
sold separately

120 cones  
per hour



### SHOWTIME!™ COTTON CANDY MACHINE

OVERALL DIMENSIONS L" X D" X H" (mm)	POWER	PLUG	SHIP WEIGHT
20½ x 20½ x 18½ (520 x 520 x 480)	110V-60Hz, 1080W, 9A	NEMA 5-15P	33 lbs (15 kgs)

ITEM	DESCRIPTION	UOM	CASE
CCM-28	Cotton Candy Machine	Set	1

Includes floss sugar scooper

### SHOWTIME!™ COTTON CANDY MACHINE WITH CART

- ◆ High polished push handle and spoked wheels
- ◆ 13" inflatable rubber tires for easy transport
- ◆ Two (2) side shelves for merchandising product (each shelf measures 11" x 12-5/8"); one side with handle and other with slots to hold cones

OVERALL DIMENSIONS L" X D" X H" (mm)	POWER	PLUG	SHIP WEIGHT
37¾ x 20½ x 34½ (959 x 520 x 876)	110V-60Hz, 1080W, 9A	NEMA 5-15P	49.6 lbs (22.5 kgs)

ITEM	DESCRIPTION	UOM	CASE
CCM-28M	Cotton Candy Machine with Cart	Set	1



### SHOWTIME!™ COTTON CANDY MACHINE ACCESSORIES

- ◆ Optional clear cover protects the bowl from wind & debris

ITEM	DESCRIPTION	UOM	CASE
CCM-28C	Clear Plastic Dome Cover 21"Dia x 14"H	Each	1/5
CCM28-P3	Replacement Belt	Each	1
CCM28-P5	Sugar Spoon	Each	1



CCM28-P10  
Shown in CCM-28M

### COTTON CANDY MACHINE FLOSS STABILIZER

- ◆ Optional floss stabilizer adds texture to the inside of the bowl and helps catch floss on its mesh surface

ITEM	DESCRIPTION	UOM	CASE
CCM28-P10	Floss Stabilizer	Each	1



CCM28-P10

### ULTRA-BRIGHT "COTTON CANDY" LED SIGN

ITEM	DESCRIPTION	UOM	CASE
92005	Ultra-Brite Sign - Cotton Candy 12"L x 1-1/4"D x 21"H	Each	5

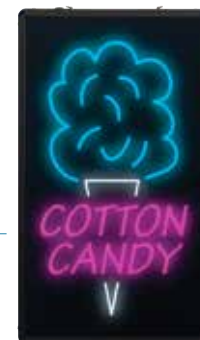

92005





## SNOW CONE MACHINES

500lbs of ice per hour



CE  
ETL US ETL Intertek Intertek  
71000



30070



CE  
ETL US ETL Intertek Intertek  
71050



74001

### SNOW CONE MACHINES

Durable and efficient, the high-volume output keeps up with busy snack bars, convenience stores, and concession stands.

- ◆ Heavy-duty 1/3hp 1700RPM motor produces up to 500 lbs (227kg) of shaved ice per hour
- ◆ Accepts cubed or chunk ice
- ◆ Cast aluminum horn, cutting head, pusher
- ◆ Adjustable stainless steel cutting blades for fine or coarse shaved ice
- ◆ Pulse-type safety reset switch prevents accidental start-up

#### "SNOW BANK" SNOW CONE MACHINE

- ◆ Tinted tempered glass panels
- ◆ Stainless steel cabinet with tempered glass panels
- ◆ Built-in snow cone shaper for perfect snow cones
- ◆ Plexiglass service door and molded plastic drainage deck with drain hose

OVERALL DIMENSIONS L" X D" X H" (mm)	POWER	PLUG	SHIP WEIGHT
16 x 16 x 24 (407 x 407 x 610)	120V-60Hz, 250W, 2.08A	NEMA 5-15P	62 lbs (28.1 kgs)

ITEM	DESCRIPTION	UOM	CASE
71000	Snow Bank Professional Snow Cone Machine	Set	1

#### "SNOW BANK" SNOW CONE CART

- ◆ Add mobility to "Snow Bank" snow cone machine
- ◆ Spoked wheels and sturdy handle for easy transport
- ◆ Shelf and operator side storage

ITEM	DESCRIPTION	UOM	CASE
30070	Cart for Snow Bank Snow Cone Machine 38"L x 23"D x 33"H	Set	1

#### "SNOW BLITZ" SNOW CONE MACHINE - PORTABLE

- ◆ Compact heavy-duty stainless steel construction
- ◆ Integrated carry handles for easy transport
- ◆ Includes 1 freezer-safe ice tote

OVERALL DIMENSIONS L" X D" X H" (mm)	POWER	PLUG	SHIP WEIGHT
22-7/8 x 18 x 18-1/2 (580 x 456 x 470)	120V-60Hz, 250W, 2.08A	NEMA 5-15P	58 lb (26.3 kgs)

ITEM	DESCRIPTION	UOM	CASE
71050	Snow Blitz Portable Snow Cone Machine	Set	1
74001	Ice Tote Box 20.5"L x 15.3"D x 7"H	Each	1

The product & package images shown are for illustration purposes and may differ from actual.



## SNOW CONE SYRUPS - 1 GALLON

◆ 4 gallons/case

ITEM	DESCRIPTION	UOM	CASE
72001CS	Blue Raspberry	Case	1
72002CS	Cherry	Case	1
72003CS	Grape	Case	1
72004CS	Lemon	Case	1
72005CS	Lime	Case	1
72006CS	Strawberry	Case	1
72007CS	Red Raspberry	Case	1
72008CS	Bubblegum	Case	1
72009CS	Green Apple	Case	1
72010CS	Root Beer	Case	1
72011CS	Orange	Case	1
72012CS	Fuzzy Navel	Case	1
72301	1 oz Pump for Syrup	Each	1

**BENCH  
MARK USA**

## SNOW CONE SUPPLIES



72002CS



72001CS



72301



72005CS



72004CS



72012CS

## SNOW CONE ACCESSORIES

ITEM	DESCRIPTION	UOM	CASE
72305	Snow Cone Scoop, S/S	Each	1
72401CS	Snow Cone Spoon Straws (assorted colors), 10,000 pcs/case	Case	1
72501	6 oz Paper Snow Cone Cups 1,000 pcs/pack	Pack	1
72701	Snow Cone Paper Cup Dispenser	Each	1

Syrups,  
pumps, cups,  
scoops, &  
straws!



72701

Shown with 6oz paper cups (sold separately)



72305



72401CS



72501

## ULTRA-BRIGHT "SNOWCONES" LED SIGN

ITEM	DESCRIPTION	UOM	CASE
92003	Ultra-Brite Sign - Snowcones 17"L x 1-1/4"D x 13"H	Each	5



92003

The product & package images shown are for illustration purposes and may differ from actual.



**winco**  
**SPECTRUM™**  
 HOT DOG ROLLER GRILLS  
 & SNEEZE GUARDS



EHDG-5R



EHDG-11R



EHDG-7R &  
EHDG-7SG



EHDG-R-SERIES



EHDG-5SG

**ROLLSRIGHT™ COUNTERTOP HOT DOG ROLLER GRILLS**

A great addition to any quick service establishment. Dual temperature controls allow for both cooking and holding areas to operate independently, reducing waste and spoilage due to excessive overheating. The RollRight™ non-stick roller surfaces stand up to continual use and are easy to clean. This versatile machine is also great for egg rolls, taquitos, sausages, and more!

- ◆ Easy-to-clean non-stick rollers; sealed ends protect internal parts
- ◆ Heavy-duty sealed motor
- ◆ Bike chain and sprocket drive assembly
- ◆ Two independent thermostatic heat controls (front & rear)
- ◆ Individual heating element in each roller for end to end temperature consistency
- ◆ Heavy duty stainless steel body and drip pan
- ◆ Re-settable fuse for safety
- ◆ Non-skid rubber feet
- ◆ Cooking surface holds up to 12 hot dogs (-5R), 18 hot dogs (-7R) and 30 hot dogs (-11R)

ITEM	OVERALL DIMENSIONS L" X D" X H" (mm)	POWER	PLUG	SHIP WEIGHT
EHDG-5R	23 x 10-½ x 7 (585 x 270 x 180)	110V~60Hz, 700W, 6.3A		17.2 lbs (7.8 kgs)
EHDG-7R	23 x 13-½ x 7 (585 x 345 x 180)	110V~60Hz, 900W, 8.1A	NEMA 5-15P	20.9 lbs (9.5 kgs)
EHDG-11R	23 x 19-¾ x 7 (585 x 505 x 180)	110V~60Hz, 1400W, 12.7A		29.7 lbs (13.5 kgs)

ITEM	DESCRIPTION	UOM	CASE
EHDG-5R	Hot Dog Roller, 5 Rollers	Set	1
EHDG-7R	Hot Dog Roller, 7 Rollers	Set	1
EHDG-11R	Hot Dog Roller, 11 Rollers	Set	1
EHDG-P10	Replacement Knob for EHDG-Series	Each	1



EHDG-11R & EHDG-11SG

**SNEEZE GUARDS FOR HOT DOG ROLLER GRILLS**

- ◆ Increase sanitation and protect food from airborne contaminants with customer-facing sneeze guards
- ◆ Durable, curved tempered glass allows customers a direct view of available food options

ITEM	DESCRIPTION	UOM	CASE
EHDG-5SG	Fits EHDG-5R	Each	1
EHDG-7SG	Fits EHDG-7R	Each	1
EHDG-11SG	Fits EHDG-11R	Each	1

## BENCHMARK HOT DOG ROLLER GRILLS

These high quality roller grills are available in 10, 20 & 30 hot dog capacities to meet any application. Stainless steel construction, removable drip trays and non-stick rollers ensure ease of cleaning. All of these grills feature a high-torque motor. 360 degree roller rotation insures evenly cooked hotdogs.

- ◆ Heavy-duty stainless steel body and removable drip tray for easy cleaning
- ◆ Heavy-duty sealed high-torque motor with bicycle chain drive
- ◆ Stainless steel non-stick rollers with sealed ends and continuous 360 degree rotation for even cooking
- ◆ Front and rear heat controllers (on 20 & 30 dog models) for cooking and holding options
- ◆ Accommodates any size hot dog, also sausage or breakfast links for expanded offerings

ITEM	OVERALL DIMENSIONS L" X D" X H" (mm)	POWER	PLUG	SHIP WEIGHT
62010	16 x 13 x 8 (407 x 330 x 203)	120V~60Hz, 660W, 5.5A		22 lbs (10 kgs)
62020	22 x 16 x 8 (559 x 406 x 203)	120V~60Hz, 860W, 7.2A	NEMA 5-15P	29 lbs (13.2 kgs)
62030	22 x 20 x 8 (559 x 508 x 203)	120V~60Hz, 1160W, 9.7A		35 lbs (15.9 kgs)

ITEM	DESCRIPTION	UOM	CASE
62010	Holds 10 Dogs	Set	1
62020	Holds 20 Dogs	Set	1
62030	Holds 30 Dogs	Set	1



62020, 64020, 65020

**BENCHMARK USA™**

## HOT DOG ROLLER GRILLS & SNEEZE GUARDS



62010



62020



62030



62010  
62020  
62030

## BENCHMARK HOT DOG ROLLER SNEEZE GUARDS

ITEM	DESCRIPTION	UOM	CASE
64010	Sneeze Guard for 10 Dog Roller Grill	Set	10
64020	Sneeze Guard for 20 Dog Roller Grill	Set	10
64030	Sneeze Guard for 30 Dog Roller Grill	Set	10



64010

## BENCHMARK HOT DOG ROLLER BUN DRAWERS - UNHEATED

ITEM	DESCRIPTION	UOM	CASE
65010	Bun Box for 10 Dog Roller Grill	Set	1
65020	Bun Box for 20 Dog Roller Grill	Set	1
65030	Bun Box for 30 Dog Roller Grill	Set	1



65010

The product & package images shown are for illustration purposes and may differ from actual.







HOT DOG EQUIPMENT



THE DOG HOUSE HOT DOG COOKER & DISPENSER

Cooks, merchandises, and dispenses hot dogs in a space-efficient 15" footprint. The Doghouse minimizes product waste and is extremely easy to use and clean.

- ◆ Easy to follow Point-of-Sale graphic allows for full service or self service operation
- ◆ Steam cooks up to 24 hot dogs in 20-30 minutes
- ◆ Holds up to 24 hot dogs and 44 buns
- ◆ Compact all stainless steel construction - requires only 15" of counter space
- ◆ No tools required for fast breakdown, easy to clean
- ◆ Adjustable thermostat for precise cooking
- ◆ First-in first-out dispensing
- ◆ Large 10Qt (9.5L) water reservoir, with low-water indicator light and safety shutoff



Holds 24 hot dogs and 44 buns

OVERALL DIMENSIONS L" X D" X H" (mm)	POWER	PLUG	SHIP WEIGHT
15 x 23 x 26 (381 x 584 x 664)	120V-60Hz, 1000W, 8.33A	NEMA 5-15P	43 lbs (19.5 kgs)

ITEM	DESCRIPTION	UOM	CASE
60024	The Dog House Hot Dog Cooker & Dispenser	Set	1

Dispense a hot dog right into the bun!



Remove a bun from the bun drawer



Place the open bun in the bun tray



Gently pull lever to dispense a hot dog into the bun

CE  
ETL Intertek  
ETL Intertek  
60024

THE DOG POUND HOT DOG STEAMER

Ideal for convenience stores, concession stands, snack bars, and cafeterias.

- ◆ Steams and holds 164 hot dogs and 36 buns
- ◆ Graphics on each side allow for front or rear counter merchandising
- ◆ Adjustable thermostat accommodates a variety of products and cooking conditions
- ◆ 7Qt (6.6L) water reservoir, with low-water indicator light and safety shutoff
- ◆ Tempered glass doors and food trays are removable for easy cleaning

Holds 164 hot dogs and 36 buns



OVERALL DIMENSIONS L" X D" X H" (mm)	POWER	PLUG	SHIP WEIGHT
15 x 16 x 19 (381 x 407 x 483)	120V-60Hz, 1000W, 8.33A	NEMA 5-15P	31 lbs (14.1 kgs)

ITEM	DESCRIPTION	UOM	CASE
60048	Dog Pound Hot Dog Steamer	Set	1



CE  
ETL Intertek  
ETL Intertek  
60048



## MINI CART HOT DOG STEAMER, 120V

Guaranteed to grab your guests' attention, this unit features wheels and an umbrella that mimic the carts found along vibrant city streets.

- ◆ Holds 60 hot dogs and 30 buns
- ◆ Mirror finish 18/8 stainless steel body
- ◆ Adjustable thermostat for cooking and holding
- ◆ Includes 1 solid half-size pan with domed lid for warming buns and 1 half-size perforated pan with flat lid for steaming hot dogs
- ◆ Outfitted with Point-of-Sale graphics, umbrella, wheels

OVERALL DIMENSIONS L" X D" X H" (mm)		POWER	PLUG	SHIP WEIGHT
21-1/2 x 13-1/4 x 16 (546 x 336 x 406) Umbrella: 35-3/4"H (908mm)		120V-60Hz, 1200W, 10A	NEMA 5-15P	33 lbs (15 kg)

ITEM	DESCRIPTION	UOM	CASE
60072	Mini Cart Hot Dog Steamer	Set	1

# BENCHMARK USA™

## HOT DOG EQUIPMENT



Holds 60 hot dogs and 30 buns



## STAINLESS STEEL CONDIMENT STATION / DISPENSER

- ◆ Insulated condiment rail and stay-open cover
- ◆ Pump wells fit #10 cans, 1.5 gallon containers, or 3qt jars
- ◆ Includes 2 ice packs, 2 pumps, & 3 ninth-size 4" deep pans

ITEM	DESCRIPTION	UOM	CASE
52001	Benchmark Condiment Station / Dispenser 27"L x 8"D x 15"H	Set	1



52001

## 18/8 STAINLESS STEEL CONDIMENT DISPENSER

- ◆ Two (2) 3-1/2 Qt plastic fountain jars included (7 Qt total)
- ◆ Each pump dispenses between 1 oz and 1-1/4 oz portions, depending on thickness of condiments
- ◆ Overall dimensions: 11"L x 8-3/4"W x 16"H (with pump)

ITEM	DESCRIPTION	UOM	CASE
PKTS-2D	Condiment Dispenser with 2 Standard Pumps	Set	1
PKTS-PT01	Individual Pump with Lid	Each	20
PKTS-PT02	Replacement Plastic Fountain Jar	Each	6
PKTS-PT03	Stainless Steel Casing	Each	1



PKTS-2D

PKTS-SERIES **BPA FREE**

## HOT DOG ACCESSORIES

ITEM	DESCRIPTION	PCS/CASE	UOM	CASE
PT-9	9" Pom Tongs, S/S		Doz	4/24
67002	Stainless Steel Tongs Holder		Each	50
68001CS	Paper Hot Dog Bags	5,000	Case	1
68002	Foil Hot Dog Bags	1,000	Case	1
68004CS	Fluted Paper Hotdog Trays	3,000	Case	1



68001CS



68002



68004CS



PT-9 & 67002

## ULTRA-BRIGHT "HOTDOGS" LED SIGN

ITEM	DESCRIPTION	UOM	CASE
92002	Ultra-Brite Sign - Hotdogs 20"L x 1-1/4"D x 13"H	Each	5



92002





**NACHO WARMERS & SUPPLIES**



51000

**100 QUART FOOD WARMER / MERCHANDISER**

*Holds and warms nacho chips, peanuts, or popcorn*

- ◆ 100 quart capacity for large or small batch use
- ◆ Merchandising signs include: "Nacho Chips", "Peanuts", and "Popcorn". Signs mount to front or back of unit
- ◆ Top-load door with a deflection board that prevents product breakage when refilling
- ◆ Built-in heating element in the base keeps contents warm and fresh
- ◆ Aluminum and tempered glass construction for durability and easy cleaning

OVERALL DIMENSIONS L" X D" X H" (mm)	POWER	PLUG	SHIP WEIGHT
15 x 15 x 30-1/2 (381 x 381 x 775)	120V-60Hz, 100W, 0.83A	NEMA 5-15P	41 lbs. (18.6 kgs)

ITEM	DESCRIPTION	UOM	CASE
51000	100 Quart Food Warmer / Merchandiser with Three Signs	Set	1



51026

**26 GALLON TORTILLA CHIP WARMER**

- ◆ Large 26 gallon (98L) capacity
- ◆ Insulated stainless steel construction
- ◆ Adjustable thermostat with 90°-180°F (32°-82°C) temperature range
- ◆ Digital temperature indicator
- ◆ Convection heating fan
- ◆ Removable front access service door
- ◆ Top-load double hinged doors
- ◆ Adjustable 4" legs

OVERALL DIMENSIONS L" X D" X H" (mm)	POWER	PLUG	SHIP WEIGHT
23 x 23 x 29 (584 x 584 x 734)	120V-60Hz, 755W, 6.3A	NEMA 5-15P	77 lbs (35 kgs)

ITEM	DESCRIPTION	UOM	CASE
51026	26 Gallon Tortilla Chip Warmer	Set	1

**NACHO ACCESSORIES**



47001 Note: serving tray style may vary from shown



53021

ITEM	DESCRIPTION	PCS/PACK	UOM	CASE
47001	Combo Serving Trays	250	Case	1
53021	Plastic Nacho Trays, 5" x 6"	500	Case	1



92004

**ULTRA-BRIGHT "NACHOS" LED SIGN**

ITEM	DESCRIPTION	UOM	CASE
92004	Ultra-Brite Sign - Nachos 16"L x 1-1/4"D x 17"H	Set	5

## PASS-THROUGH TWO-DOOR WARMERS/ MERCHANDISERS

These versatile 2-Door Warmers /Merchandisers are ideal for front or rear counter applications. The operator side has the controls and a door for easy loading. The customer side door makes it a self-serve unit.

- ◆ Two doors for front or rear counter applications
- ◆ Attractive graphics for point-of-sale merchandising

## PASS-THROUGH ROTATING DISPLAY WARMERS/MERCHANDISERS

- ◆ Heated cabinet with passive humidity control
- ◆ Stainless steel and tempered glass
- ◆ Adjustable thermostat with cabinet temperature readout
- ◆ Dual fixture interior illumination (bulbs not included)
- ◆ Includes chrome-plated 5-tier round pan rack (pizza) and hook rack (pretzels, churros)
- ◆ Continuous rotating rack stops when either door opens
- ◆ Adjustable 4" legs

ITEM	OVERALL DIMENSIONS L" X D" X H" (mm)	POWER	PLUG	SHIP WEIGHT
51012	18-1/8 x 22 x 33 (460 x 559 x 838)	120V-60Hz, 1560W, 13A	NEMA 5-15P	86 lbs (39 kgs)
51018	24-1/2 x 27 x 33 (622 x 686 x 838)			117 lbs (53.1 kgs)

ITEM	DESCRIPTION	UOM	CASE
51012	12" Warmer/Merchandiser	Set	1
51018	18" Warmer/Merchandiser	Set	1

## BENCH MARK USA™ HEATED DISPLAY MERCHANDISERS



51012  
Shown with  
12" hook rack  
installed



51018  
Shown with 18"  
pizza round rack  
installed



51012  
51018

## PASS-THROUGH WARMERS/MERCHANDISERS

- ◆ Adjustable thermostat, 450 watt element
- ◆ Stainless steel and aluminum construction
- ◆ Tempered glass panels and doors
- ◆ Chrome-plated racks with adjustable installation - either lay flat or slanted

ITEM	OVERALL DIMENSIONS L" X D" X H" (mm)	POWER	PLUG	SHIP WEIGHT
51040	16 x 16 x 23 (407 x 407 x 584)	120V-60Hz, 600W, 5A	NEMA 5-15P	40 lbs (18.2 kgs)
51048	23 x 23 x 25½ (584 x 584 x 648)			62 lbs (28.1 kgs)

ITEM	DESCRIPTION	UOM	CASE
51040	12" Warmer/Merchandiser	Set	1
51048	18" Warmer/Merchandiser	Set	1



51040  
Fits up to 12"  
diameter pizza



51048  
Fits up to 18"  
diameter pizza



51040  
51048

## ULTRA-BRITE "PIZZA" LED SIGN

ITEM	DESCRIPTION	UOM	CASE
92006	Ultra-Brite Sign - Pizza	Each	5



92006



# HEATED DISPLAY MERCHANDISERS



EDM-1K  
Matte Black  
(Single Door)



Control Panel

## HEATED & HUMIDIFIED HOLDING DISPLAY MERCHANDISERS

Keep hot foods fresher for longer with this heat and humidity controlled merchandiser. The airflow pattern is designed to maintain consistent temperature and humidity around foods and prevent drying, which also enables the unit to recover temperature quickly after doors are opened/closed.

- ◆ Powder-coated exterior, stainless steel interior
- ◆ Clear-view tempered glass on all sides, with server-side easy access swing door
- ◆ LED interior illumination provides optimal visibility
- ◆ Digital adjustable thermostat and humidity control
- ◆ Temperature range: 89°F to 194°F (30°C to 90°C)
- ◆ Optional pretzel rack insert available, sold separately

### EDM-1K MATTE BLACK

- ◆ Server-side easy access swing door
- ◆ 4-tier round rack continuously rotates - rotation stops when door is opened
- ◆ Each shelf fits up to 18" diameter pan

### EDM-1PT RED

- ◆ 2 pass-through swing doors
- ◆ Rotating motor to accept optional round rack
- ◆ 3 display shelves showcase food products

ITEM	OVERALL DIMENSIONS L" X D" X H" (mm)	POWER	PLUG	SHIP WEIGHT
EDM-1K	23-5/8 x 25-3/8 x 27-9/16 (600 x 643 x 700)	120V-60Hz, 1500W, 13.1A	NEMA 5-15P	85 lbs (38.6 kgs)
EDM-1PT	23-5/8 x 26 x 27-9/16 (600 x 660 x 700)			



EDM-1PT  
Red  
(Double Door)



2 pass-through  
swing doors



ITEM	DESCRIPTION	UOM	CASE
EDM-1K	Merchandiser, 1 Door, Black	Set	1
EDM-1PT	Merchandiser, 2 Doors, Red	Each	1
EDM-P39	4-Tier Round Rack, 18" Dia	Each	5
EDM-1PR	Pretzel Rack for EDM-1K	Each	1
EDM1-P36	Display Shelf Kit (3 Shelves & 12 Shelf Clips) fits EDM-1K or EDM-1PT	Pack	1



EDM-1PR  
Optional Pretzel Rack



EDM-1K  
EDM-1PT



New Item

**ELECTRIC HEATED PIZZA/PRETZEL MERCHANDISERS**

Passive humidity control with removable water tray.

- ◆ Interior wire shelves hold four (4) 14" pizzas
- ◆ Optional pretzel rack insert, sold separately
- ◆ Display tray/rack insert rotates when door is closed
- ◆ Lighted display panel for branding visuals
- ◆ Adjustable thermostat from 85°F to 195°F (30°C to 90°C)
- ◆ Removable crumb tray

OVERALL DIMENSIONS L" X D" X H" (mm)	POWER	PLUG	SHIP WEIGHT
18-3/8 x 17-5/8 x 31 (466 x 447 x 785)	110-120V~60Hz, 786W, 7.2A	NEMA 5-15P	55.2 lbs (25 kgs)



ITEM	DESCRIPTION	UOM	CASE
EDM-2	Heated Pizza/Pretzel Merchandiser	Set	1
EDM-2PR	Optional Pretzel Rack Insert	Set	1
EDM-2PRS	Pretzel Sign, 5-3/4"H x 16-1/8"W	Each	1
EDM-2PZS	Pizza Sign, 5-3/4"H x 16-1/8"W	Each	1
EDM-P58	4-Tier Round Rack, 14" Dia	Each	5

**Translucent plastic display sign options**



EDM-2PRS



EDM-2PZS



EDM-2PR  
Optional Pretzel Rack



Control Panel



EDM-2



Back-lit display (signs sold separately)

**COUNTERTOP HEATED DISPLAY MERCHANDISERS**

These merchandisers feature passive humidity control with a removable water tray.

- ◆ Removable water pan to add and control humidity
- ◆ Three (3) adjustable shelves inside, top of unit also functional as a shelf
- ◆ Lighted front display for branding visuals
- ◆ Visible thermometer gauge to ensure food keeps at proper temperatures
- ◆ Adjustable thermostat from 85°F to 195°F (30°C to 90°C)
- ◆ Customer-facing front service and rear access doors

ITEM	OVERALL DIMENSIONS L" X D" X H" (mm)	POWER	PLUG	SHIP WEIGHT
HDM-13	13-11/16 x 19-2/16 x 26-1/8 (347 x 495 x 663)	110-120V~60Hz, 800W, 7.6A	NEMA 5-15P	50.7 lbs (23 kgs)
HDM-26	26-11/16 x 19-2/16 x 26-1/8 (677 x 495 x 663)	110-120V~60Hz, 1000W, 9.5A		79.4 lbs (36 kgs)



ITEM	DESCRIPTION	UOM	CASE
HDM-13	13-1/2"L	Set	1
HDM-26	26-1/2"L	Set	1

**HEATED DISPLAY MERCHANDISERS**



Accepts 1/4-size sheet pans

HDM-13



HDM-26



Control Panel



HDM-SERIES



REFRIGERATED COLD BEVERAGE DISPLAY



CRD-1

CRD-Series uses environmentally friendly R290 refrigerant



CRD-1K

COUNTERTOP REFRIGERATED BEVERAGE DISPLAYS

With its clear panels and 4 LED light strips, this countertop display can keep up to 100 standard 12 oz cans chilled. These units use R290 refrigerant making them an environmentally-responsible choice.

- ◆ Digital temperature display from 32°F to 42°F (0°C - 6°C)
- ◆ R-290 environmentally safe refrigerant
- ◆ 360° view of refrigerated product
- ◆ 2 double, curved-glass doors for dual access and easy placement of inner contents
- ◆ 4 LED strips for effective product lighting
- ◆ Comfortably fits up to 100 cans (standard 12 oz) with 25 cans per shelf
- ◆ 4-level merchandising display; three (3) shelves are adjustable to fit multiple product heights
- ◆ Automatic defrost and ventilated cooling system

OVERALL DIMENSIONS L" X D" X H" (mm)	POWER	PLUG	SHIP WEIGHT
16¾ x 16 <sup>15</sup> / <sub>16</sub> x 38½ (425 x 429 x 978)	110-120V~60Hz, 180W, 1.7A	NEMA 5-15P	85.89 lbs (39 kgs)
SHELF DIMENSIONS L" X D" (mm)			
14-3/8 x 12-1/8 (365 x 307)			

ITEM	DESCRIPTION	UOM	CASE
CRD-1	White	Set	1
CRD-1K	Black	Set	1

**IMPORTANT**  
CRD-1 / -1K units are intended for use in commercial food-service operations, for display and cooling of sealed cold foods and cold beverages only.

Fits up to 100 cans





# POWER & PERFORMANCE



High-performance motor with impact-resistant stainless steel blades adds power and performance to your busy establishment.

## 68 OZ (2 L) LARGE CAPACITY COMMERCIAL BLENDER

- ◆ 68 oz (2 L), break-resistant and BPA-free Tritan™ container
- ◆ High-performance 2 hp motor; unique high-impact blades
- ◆ Metal-to-metal coupling; easy to operate "PULSE"
- ◆ "ON /OFF" paddle controls & variable speed control dial
- ◆ Base footprint 9" x 10"
- ◆ Container/pitcher is heat-resistant up to 226°F (108°C); reduce pressure by removing cap in the lid
- ◆ Removable container cover and cap for adding/blending ingredients mid-cycle
- ◆ 11-1/2" tamper included - fits through lid opening and reaches full length of container to blend/stir while mixing
- ◆ All parts (except bases & blade fixing block) are dishwasher safe

OVERALL DIMENSIONS L" X D" X H" (mm)	POWER	PLUG	SHIP WEIGHT
8-11/16 x 9-13/16 x 19-15/16 (220 x 249 x 490)	120V~60Hz, 1450W, 12.1A	NEMA 5-15P	10.4 lbs (4.7 kgs)
CONTAINER DIMENSIONS L" X D" X H" (mm)			
6-11/16 x 6-11/16 x 12-3/8 (178 x 18 x 314)			

ITEM	DESCRIPTION	UOM	CASE
▶ XLB-1000	68 Oz Blender	Set	1/4
▶ XLB1000P2	Pitcher Assembly	Each	1
▶ XLB1000P19	Blade Removal Tool	Each	1

## BLENDERS

Blade removal tool included



XLB1000P19

XLB-1000



TRITAN™ CONTAINER



## 44 OZ (1.25 L) 2-SPEED QUIET BAR BLENDER

- ◆ 44 oz (1.25 L), break-resistant and BPA-free Tritan™ container
- ◆ Quiet, high-performance 1/2 hp self-lubricating motor; uniquely designed high-impact blades
- ◆ HIGH/LOW toggle switch for precise consistency control
- ◆ Base footprint 6-1/2" x 8"
- ◆ Blade is removable for easy cleaning
- ◆ Non-skid feet securely grip the surface for stable operation
- ◆ Removable container cover and cap for adding/blending ingredients mid-cycle

OVERALL DIMENSIONS L" X D" X H" (mm)	POWER	PLUG	SHIP WEIGHT
7 x 7-7/16 x 15-7/16 (178 x 189 x 392)	120V~60Hz, 400W, 3.5A	NEMA 5-15P	5.5 lbs (2.5 kgs)
CONTAINER DIMENSIONS L" X D" X H" (mm)			
7x 8-1/8 x 9-7/16 (178 x 130 x 235)			

ITEM	DESCRIPTION	UOM	CASE
▶ XLB-44	44 Oz Blender	Set	1/4
▶ XLB44-P10	Pitcher Assembly	Each	1



XLB-44



TRITAN™ CONTAINER



ELECTRIC COFFEE URNS



ELECTRIC STAINLESS STEEL COFFEE URNS

Brew consistent, quality coffee with these percolating coffee urns. Available in either 50 or 100 cup capacities, contents are maintained at the ideal serving temperature until the sight glass indicates when it's time to refill.

- ◆ Large capacity brews 50 or 100 cups of 5oz (148ml) coffee
- ◆ Polished #304 stainless steel construction
- ◆ Twist-locking lid design
- ◆ Cool touch handles
- ◆ Dripless faucet with protected level indicator
- ◆ Waterproof ON/OFF switch with protective cover
- ◆ Stainless steel percolator pipe and plastic filter basket
- ◆ Heating and holding indicator lights
- ◆ Automatic shut-off safety feature



ECU-50A



ECU-100A  
ECU-100A-I



ECU-50A  
ECU-100A



ECU-100A-I

ITEM	OVERALL DIMENSIONS L" X D" X H" (mm)	POWER	PLUG	SHIP WEIGHT
ECU-50A	12 x 8- <sup>11</sup> / <sub>16</sub> x 16- <sup>3</sup> / <sub>8</sub> (304 x 220 x 415)	110-120V-60Hz, 950W, 8A	NEMA 5-15P	7.1 lbs (3.2 kgs)
ECU-100A	13- <sup>15</sup> / <sub>16</sub> x 10- <sup>5</sup> / <sub>8</sub> x 19- <sup>11</sup> / <sub>16</sub> (353 x 270 x 500)	110-120V-60Hz, 1500W, 12.5A		9.7 lbs (4.4 kgs)
ECU-100A-I			220-240V-50Hz, 1650W, 6.9-7.5A	VDE

ITEM	DESCRIPTION	UOM	CASE
ECU-50A	50-Cup (8L)	Set	1/2
ECU-100A	100-Cup (16L)	Set	1/2
ECU-100A-I	100-Cup (16L), International	Set	1/2
EWCU-P3	Faucet Assembly	Each	1



Twist-locking lid



Cool-touch handles



Dripless faucet with clear-view level indicator



## HOT BEVERAGE/TOPPING DISPENSER

This 5-quart capacity heated dispenser uses rotating paddles, making it perfect for nacho cheese, butter topping, hot chocolate, au jus, and more.

- ◆ 1.3 gallon (5L) capacity
- ◆ Removable, clear polycarbonate bowl, safe for refrigerated storage of unused product
- ◆ Easy-to-disassemble tap
- ◆ Adjustable thermostat up to 194°F (90°C)
- ◆ Rotating mixing paddles to prevent product separation
- ◆ Easy-to-clean removable drip tray
- ◆ Includes 2 replacement bowl sealing rings

OVERALL DIMENSIONS L" X D" X H" (mm)	POWER	PLUG	SHIP WEIGHT
10 x 13 x 20 (254 x 330 x 508)	120V~60Hz, 1100W, 9.2A	NEMA 5-15P	15 lbs (6.8 kgs)

ITEM	DESCRIPTION	UOM	CASE
21011	Hot Beverage/ Topping Dispenser	Each	1/2

# BENCHMARK USA™

## HOT BEVERAGE/ TOPPING DISPENSER



ETL  
Intertek  
21011

## ELECTRIC STAINLESS STEEL WATER BOILERS

These water boilers are a great addition to any hot beverage service, heating and holding hot water ready to dispense as needed, until the sight glass indicates when it's time to refill.

- ◆ Large 2.1 gallon (8L) or 4.2 gallon (16L) capacities
- ◆ Polished #304 stainless steel construction
- ◆ Twist-locking lid design
- ◆ Cool touch handles
- ◆ Dripless faucet with protected level indicator
- ◆ Waterproof ON/OFF switch with protective cover
- ◆ Heating and holding indicator lights
- ◆ Automatic shut-off safety feature

ITEM	OVERALL DIMENSIONS L" X D" X H" (mm)	POWER	PLUG	SHIP WEIGHT
EWB-50A	12 x 8- <sup>11</sup> / <sub>16</sub> x 16- <sup>3</sup> / <sub>8</sub> (304 x 220 x 415)	110-120V~60Hz, 1300W, 10.8A	NEMA 5-15P	6 lbs (2.7 kgs)
EWB-100A	13- <sup>15</sup> / <sub>16</sub> x 10- <sup>5</sup> / <sub>8</sub> x 19- <sup>11</sup> / <sub>16</sub> (353 x 270 x 500)	110-120V~60Hz, 1500W, 12.5A		8.4 lbs (3.8 kgs)
EWB-100A-I			220-240V~50Hz, 2250W, 9.4A	VDE

ITEM	DESCRIPTION	UOM	CASE
EWB-50A	2.1 Gallon (8L)	Set	1/2
EWB-100A	4.2 Gallon (16L)	Set	1/2
EWB-100A-I	4.2 Gallon (16L), International	Set	1/2
EWCU-P3	Faucet Assembly	Each	1

## ELECTRIC WATER BOILERS



EWB-50A



EWB-100A  
EWB-100A-I

ETL  
Intertek

EWB-50A  
EWB-100A

CE  
EWB-100A-I



Dripless faucet with  
protected level  
indicator



Cool-touch handles



Twist-locking lid



## ELECTRIC KETTLE SOUP WARMERS



ESW-70

The extra large kettle-style soup warmers keep contents at safe serving temperatures for hours, great for serving all day long.

- ◆ Up to 10-quart capacity
- ◆ Adjustable heat control keeps contents at a safe serving temperature without overcooking
- ◆ Stainless steel hinged lid features extra-large ladle slot; hinges allow cover to remain attached while opened and closed when in service with no drips
- ◆ Sets include a removable stainless steel bain marie inner pot
- ◆ Double-wall insulated construction allows outer surface to stay cool-to-touch

### ELECTRIC STAINLESS STEEL KETTLE SOUP WARMER

- ◆ Includes suction-grip label holder

OVERALL DIMENSIONS L" x D" x H" (mm)	POWER	PLUG	SHIP WEIGHT
13- <sup>3</sup> / <sub>16</sub> x 13- <sup>3</sup> / <sub>16</sub> x 15 (335 x 335 x 381)	110V-50/60Hz, 400W, 3.6A	NEMA 5-15P	13.14 lbs (5.9 kgs)

ITEM	DESCRIPTION	UOM	CASE
ESW-70	S/S Kettle Soup Warmer Set	Set	1
ESW70-INS	S/S Insert for ESW-70	Each	2
INSH-7	Hinged Cover for ESW70-INS	Each	6/24
ESW70-P6	Replacement Knob	Each	1



ESW-66-I



ESW-66

### ELECTRIC DELUXE BLACK KETTLE SOUP WARMER

- ◆ Includes customizable magnetic label holder, plus a variety of pre-printed soup name labels

ITEM	OVERALL DIMENSIONS L" x D" x H" (mm)	POWER	PLUG	SHIP WEIGHT
ESW-66	13- <sup>3</sup> / <sub>16</sub> x 13- <sup>3</sup> / <sub>16</sub> x 15 (335 x 335 x 381)	110V-50/60Hz, 400W, 3.6A	NEMA 5-15P	12.4 lbs (5.6 kgs)
ESW-66-I	13- <sup>3</sup> / <sub>16</sub> x 13- <sup>3</sup> / <sub>16</sub> x 15 (335 x 335 x 381)	220V-50/60 Hz, 500W, 2.5A	NEMA 5-15P	12.4 lbs (5.6 kgs)

ITEM	DESCRIPTION	UOM	CASE
ESW-66	Black Kettle Soup Warmer Set	Set	1
ESW-66-I	Black Kettle Soup Warmer Set, International	Set	1
ESW-INS	S/S Insert Pot for ESW-66	Each	2
INSH-7	Hinged Cover for ESW-INS	Each	6/24
ESW66-P38	Replacement Knob	Each	1



ESW-SERIES



ESW-INS



INSH-7

Extra large ladle slot

## ELECTRIC WATER PAN



EWP-2

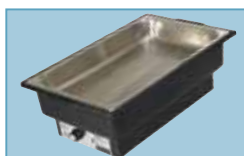

Holds full-size steam table pan. Use as freestanding unit or fits inside standard full-size chafers.

### ELECTRIC WATER PAN

Add ease and convenience with this versatile, energy efficient 120 Volt alternative to chafing fuels. It fits most full-size chafers or use as a freestanding unit.

- ◆ Stands alone or fits standard full-size chafers for an electric alternative (food pan sold separately)
- ◆ Accommodates full-size steam table pans
- ◆ Adjustable controls keep contents at safe serving temp
- ◆ Powerful, efficient 900W heating element heats up fast

OVERALL DIMENSIONS L" x D" x H" (mm)	POWER	PLUG	SHIP WEIGHT
22- <sup>5</sup> / <sub>16</sub> x 13- <sup>3</sup> / <sub>16</sub> x 7 (575 x 346 x 178)	120V-60Hz, 900W, 7.5A	NEMA 5-15P	6 lbs (2.72 kgs)

ITEM	DESCRIPTION	UOM	CASE
EWP-2	900W, Full-Size	Each	1

Holds a full-size steam table pan and fits in standard full-size chafers

## ELECTRIC 30-CUP RICE COOKER

- ◆ Holds up to 30 cups of uncooked rice or up to 60 cups of cooked rice
- ◆ Removable inner pot seals in moisture
- ◆ Automatic warming up to 2 hours

OVERALL DIMENSIONS L" x D" x H" (mm)	POWER	PLUG	SHIP WEIGHT
19-7/8 x 17-1/2 x 13-3/8 (505 x 445 x 340)	110V~50/60Hz, 1550W, 13A	NEMA 5-15P	18 lbs (8.2 kgs)



ITEM	DESCRIPTION	UOM	CASE
RC-P301	Rice Cooker, 30-Cup	Set	1
RC-P301PN	Inner pot for RC-P301	Each	1

Replaces RC-P300



## ELECTRIC 30-CUP RICE COOKER & WARMER WITH HINGED LID

- ◆ Holds up to 30 cups of uncooked rice or up to 60 cups of cooked rice
- ◆ Fingerprint-proof satin finish; heavy-duty stainless steel body
- ◆ Removable non-stick inner pot seals in moisture
- ◆ Energy efficient heat absorption system
- ◆ Automatic warming up to 6 hours

OVERALL DIMENSIONS L" x D" x H" (mm)	POWER	PLUG	SHIP WEIGHT
19 x 15-7/8 x 13-7/8 (483 x 397 x 350)	120V~60Hz, 1550W, 13A	NEMA 5-15P	24 lbs (10.9 kgs)



ITEM	DESCRIPTION	UOM	CASE
RC-S301	Rice Cooker/Warmer, Hinged Lid, 30-Cup	Set	1
RC-S301PN	Inner Pot for RC-S301	Each	1
RCW-P1	Serving Paddle	Each	1
RCS301-P1	Measuring Cup	Each	1
RCS301-P8	Fuse for RC-S301	Each	1

Replaces RC-S300



## ELECTRIC 100-CUP RICE WARMER WITH HINGED LID

- ◆ Holds up to 100 cups of cooked rice for warming
- ◆ Fingerprint-proof satin finish; heavy-duty stainless steel body
- ◆ Removable non-stick inner pot seals in moisture
- ◆ Energy efficient heat absorption system
- ◆ Warming up to 12 hours

OVERALL DIMENSIONS L" x D" x H" (mm)	POWER	PLUG	SHIP WEIGHT
19 x 14-7/8 x 17-7/8 (483 x 381 x 378)	120V~60Hz, 103W, 0.8A	NEMA 5-15P	20.7 lbs (9.4 kgs)



ITEM	DESCRIPTION	UOM	CASE
RW-S451	Rice Warmer, Hinged Lid, 100-Cup	Set	1
RW-S451PN	Inner pot for RW-S451	Each	1
RCW-P1	Serving Paddle	Each	1

Replaces RW-S450



## PANASONIC ELECTRIC 23-CUP RICE COOKER

- ◆ Holds up to 23 cups of uncooked rice or up to 46 cups of cooked rice
- ◆ Removable Inner pot seals in moisture
- ◆ Warming up to 2 hours

OVERALL DIMENSIONS L" x D" x H" (mm)	POWER	PLUG	SHIP WEIGHT
16-7/8 x 14-7/8 x 11-7/8 (429 x 378 x 302)	120V~60Hz, 1550W, 13A	NEMA 5-15P	15.3 lbs (6.94 kgs)

ITEM	DESCRIPTION	UOM	CASE
SR-42HZP-D	Panasonic Commercial Rice Cooker, 23-Cup	Set	1



# ELECTRIC ROUND FOOD COOKERS/WARMERS

With highly efficient heating distribution, Winco's durable and reliable food warmers & cookers/warmers are workhorses that can endure the harshest kitchen environments.

- ◆ Insulated heating compartment for maximum efficiency
- ◆ No-drip rim keeps serving area clean

Fits 7qt inset pot



With inset pot



FW-7R250



FW-7R-SERIES

## ELECTRIC ROUND FOOD WARMERS (WET WELL USE ONLY)

- ◆ 3 settings: Low / Medium / High

ITEM	OVERALL DIMENSIONS L" x D" x H" (mm)	WELL OPENING L" x D" x H" (mm)	POWER	PLUG	SHIP WEIGHT
FW-11R250	12-1/2 x 12-1/2 x 9-5/8 (518 x 318 x 245)	10-1/2 x 10-1/2 x 6-1/4 (267 x 267 x 160)	120V-50/60Hz, 750W	NEMA 5-15P	13.5 lbs (6.1 kgs)
FW-7R250	11 x 11 x 9-1/2 (280 x 280 x 241)	8-1/4 x 8-1/4 x 6 (210 x 210 x 153)	120V-50/60Hz, 550W	NEMA 5-15P	9.48 lbs (4.3 kgs)

ITEM	DESCRIPTION	UOM	CASE
FW-11R250	11 Qt Warmer	Set	1
FW-7R250	7 Qt Warmer	Set	1

Fits 11qt inset pot



FW-11R500



FW-11R-SERIES

## ELECTRIC ROUND FOOD COOKERS/WARMERS (WET WELL USE ONLY)

- ◆ Heats up to 212°F (100°C)

ITEM	OVERALL DIMENSIONS L" x D" x H" (mm)	WELL OPENING L" x D" x H" (mm)	POWER	PLUG	SHIP WEIGHT
FW-11R500	12-1/2 x 12-1/2 x 9-5/8 (518 x 318 x 245)	10-1/2 x 10-1/2 x 6-1/4 (267 x 267 x 160)	120V-50/60Hz, 1250W	NEMA 5-15P	12.6 lbs (5.7 kgs)
FW-7R500	11 x 11 x 9-1/2 (280 x 280 x 241)	8-1/4 x 8-1/4 x 6 (210 x 210 x 153)	120V-50/60Hz, 1050W	NEMA 5-15P	9.1 lbs (4.3 kgs)

ITEM	DESCRIPTION	UOM	CASE
FW-11R500	11 Qt Cooker/Warmer	Set	1
FW-7R500	7 Qt Cooker/Warmer	Set	1



FW11R-ADP

## FOOD COOKERS/WARMERS ACCESSORIES

ITEM	DESCRIPTION	UOM	CASE
INS-11.0M	11Qt Inset Pan	Each	6/12
INS-7.0M	7 Qt Inset Pan	Each	6/24
FW11R-ADP	Adaptor Ring	Each	1/6



Adaptor ring quickly converts 11qt food cookers/warmers to fit 7qt inset pan



### ELECTRIC 4/3 SIZE FOOD WARMER, 1500W (WET WELL USE ONLY)

This commercial-grade food warmer fits four (4) 1/3-size food pans in the extended 27" long well opening, and allows for other pan configurations. Featuring a heavy-duty stainless steel welded body, the energy efficient design heats quickly.

- ◆ Energy-efficient design for fast heating
- ◆ Heavy-duty stainless steel welded body
- ◆ Reliable temperature control for graduated heat settings
- ◆ Dedicated indicator light to easily monitor heating status

OVERALL DIMENSIONS L" x D" x H" (mm)	WELL OPENING L" x D" x H" (mm)	POWER	PLUG	SHIP WEIGHT
14-5/8 x 29-3/4 x 10-5/8 (370 x 755 x 270)	11-13/16 x 27 x 6-5/16 (300 x 658 x 160)	120V-50/60Hz, 1500W, 12.5A	NEMA 5-15P	29.4 lbs (13.4 kgs)



ITEM	DESCRIPTION	UOM	CASE
FW-L600	4/3 Size Warmer	Set	1
FWS600-P5	Power/Thermostat Knob	Each	1

### ELECTRIC 4/3 SIZE FOOD WARMER



(1) FULL SIZE, (1) 1/3 SIZE



(4) 1/3 SIZE PANS

27" long well opening



FW-L600

These commercial-grade units accommodate a full-size food pan and allows for other pan configurations. Featuring a heavy-duty stainless steel welded body, the energy efficient design heats quickly.

- ◆ Energy-efficient design for fast heating
- ◆ Heavy-duty stainless steel welded body
- ◆ Reliable temperature control for graduated heat settings
- ◆ Dedicated indicator light to easily monitor heating status

### ELECTRIC FULL-SIZE FOOD COOKERS/WARMERS

#### ELECTRIC FULL-SIZE FOOD COOKER/WARMER, 1500W (WET WELL USE ONLY)

OVERALL DIMENSIONS L" x D" x H" (mm)	WELL OPENING L" x D" x H" (mm)	POWER	PLUG	SHIP WEIGHT
14-5/8 x 22-1/2 x 10-5/8 (370 x 572 x 270)	12 x 20 x 6 (305 x 508 x 153)	120V-50/60Hz, 1500W, 12.5A	NEMA 5-15P	25 lbs (11.4 kgs)



ITEM	DESCRIPTION	UOM	CASE
FW-S600	Cooker/Warmer	Set	1
FWS600-P5	Power/Thermostat Knob	Each	1



FW-S600

#### ELECTRIC FULL-SIZE FOOD WARMER, 1200W (WET WELL USE ONLY)

OVERALL DIMENSIONS L" x D" x H" (mm)	WELL OPENING L" x D" x H" (mm)	POWER	PLUG	SHIP WEIGHT
14-5/8 x 22-1/2 x 9-3/8 (370 x 572 x 238)	12 x 20 x 6 (305 x 508 x 153)	120V-50/60Hz, 1200W, 10A	NEMA 5-15P	23.2 lbs (10.52 kgs)



ITEM	DESCRIPTION	UOM	CASE
FW-S500	Warmer	Set	1
FWS500-P11	Power/Thermostat Knob	Each	1



FW-S500





FOOD WARMERS



Adaptor plate included



STAINLESS STEEL ELECTRIC FOOD WARMER

This warmer accepts most popular warmer pans, adaptors and lids. The adjustable thermostat allows for virtually any type of cooking or holding condition.

- ◆ Mirror finish 18/8 stainless steel body
- ◆ Precise control adjustable thermostat
- ◆ Includes two-hole adaptor plate for 7Qt inserts
- ◆ Accepts all standard pans, adaptors and lids
- ◆ Water-resistant covered power switch
- ◆ 3-1/2" adjustable legs

OVERALL DIMENSIONS L" x D" x H" (mm)	POWER	PLUG	SHIP WEIGHT
13-1/4 x 21-1/2 x 12-1/2 (336 x 546 x 318)	120V-60Hz, 1200W, 10A	NEMA 5-15P	22 lbs (10 kgs)
WELL OPENING L" x D" x H" (mm)			
12 x 20 x 6-1/4 (305 x 508 x 159)			

ITEM	DESCRIPTION	UOM	CASE
51096	1200W Warmer	Set	1

DUAL-WELL ELECTRIC FOOD WARMERS (PLAIN SIDES, NO GRAPHIC)



51072P

ITEM	OVERALL DIMENSIONS L" x D" x H" (mm)	POWER	PLUG	SHIP WEIGHT
51072P	21-1/2 x 13-1/4 x 17 (546 x 336 x 432)*	120V-60Hz, 1200W, 10A	NEMA 5-15P	27 lbs (12.3 kgs)
51073P				28 lbs (12.7 kgs)
51074P				30 lbs (13.6 kgs)

\*Pump models 20" (508mm) height

ITEM	DESCRIPTION	UOM	CASE
51072P	Warmer with 2 Ladles/Lids	Set	1
51073P	Warmer with 1 Pump & 1 Ladle/Lid	Set	1
51074P	Warmer with 2 Pumps	Set	1

FOOD WARMER ACCESSORIES



SPHP4

SPJM-204

SPSCH

C-DCH

LDI-3

ADP-808

ITEM	DESCRIPTION	UOM	CASE
SPHP4	Half-Size Perforated Steam Pan, 4", 25 Ga S/S	Each	6/24
SPJM-204	Half-Size Anti-Jam Steam Pan, 4", 24 Ga S/S	Each	6/24
SPSCH	Half-Size Steam Pan Cover, Solid	Each	12/48
C-DCH	Half-Size Dome Cover, S/S	Each	24
LDI-3	3 oz Ladle, S/S	Each	12/120
ADP-808	Adaptor Plate w/ Two Holes (7qt), S/S	Each	10
INS-7.0M	7 Qt Inset Pan, S/S	Each	6/24
INSH-7	Hinged Inset Cover, S/S	Each	6/24
56752	Condiment Pump for 7 Quart Inset Pan, S/S	Each	1/10



INS-7.0M



INSH-7



56752

# Themed Electric Food Warmers

Themed warmers offer style and flexibility with attractive graphics for point-of-sale merchandising, and multiple insert configurations to meet operational needs.



THEMED FOOD WARMERS

## "CHICKEN WINGS" WARMER

- ◆ 2 half size pans, 2 domed lids, tongs and tongs holder

OVERALL DIMENSIONS L" x D" x H" (mm)	POWER	PLUG	SHIP WEIGHT
21-½ x 13-¼ x 16 (546 x 336 x 406)	120V-60Hz, 1200W, 10A	NEMA 5-15P	27 lbs (12.3 kgs)

ITEM	DESCRIPTION	UOM	CASE
51072W	Chicken Wings Warmer	Set	1



51072W

## "CHILI & CHEESE" WARMER

ITEM	OVERALL DIMENSIONS L" x D" x H" (mm)	POWER	PLUG	SHIP WEIGHT
51072A	21-½ x 13-¼ x 17 (546 x 336 x 432)*	120V-60Hz, 1200W, 10A	NEMA 5-15P	27 lbs (12.3 kgs)
51073A				28 lbs (12.7 kgs)
51074A				30 lbs (13.6 kgs)

\*Pump models 20" (508mm) height

ITEM	DESCRIPTION	UOM	CASE
51072A	Warmer with 2 Ladles/Lids	Set	1
51073A	Warmer with 1 Pump & 1 Ladle/Lid	Set	1
51074A	Warmer with 2 Pumps	Set	1



51074A

## "HOT FUDGE & CARAMEL" WARMER

ITEM	OVERALL DIMENSIONS L" x D" x H" (mm)	POWER	PLUG	SHIP WEIGHT
51072H	21-½ x 13-¼ x 17 (546 x 336 x 432)*	120V-60Hz, 1200W, 10A	NEMA 5-15P	27 lbs (12.3 kgs)
51073H				28 lbs (12.7 kgs)
51074H				30 lbs (13.6 kgs)

\*Pump models 20" (508mm) height

ITEM	DESCRIPTION	UOM	CASE
51072H	Warmer with 2 Ladles/Lids	Set	1
51073H	Warmer with 1 Pump & 1 Ladle/Lid	Set	1
51074H	Warmer with 2 Pumps	Set	1



51073H

## "DELICIOUS SOUPS" WARMER

OVERALL DIMENSIONS L" x D" x H" (mm)	POWER	PLUG	SHIP WEIGHT
21-½ x 13-¼ x 17 (546 x 336 x 432)	120V-60Hz, 1200W, 10A	NEMA 5-15P	27 lbs (12.3 kgs)

ITEM	DESCRIPTION	UOM	CASE
51072S	Soup Station, 2 Ladles & Lids	Set	1



51072S





## STRIP HEATERS



ESH-36  
Shown with undermount bracket and hanging chain

Includes hanging brackets & chains



Built-in plug



Heating element



Indicator light and toggle switch



Designed with a tubular sheath heating element, these premium quality electric strip heaters provide constant, even, and reliable infrared heating. Undermount and freestanding options available.

- ◆ Heavy-duty one piece extruded aluminum body for durability and cleanliness
- ◆ Aluminum heat reflectors with focused heat pattern to maximize holding times
- ◆ On/off toggle switch and 180° full view indicator light for easy operation

### UNDERMOUNT ELECTRIC STRIP HEATERS

- ◆ Ideal for pass-through stations or under shelf installations
- ◆ Each unit includes undermount bracket set w/screws and hanging chains

ITEM	OVERALL DIMENSIONS L" X D" X H" (mm)	POWER	PLUG & CORD	SHIP WEIGHT
ESH-24	24 x 6 x 2-7/16 (610 x 153 x 67)	120V-50/60Hz, 500W, 4.2A	NEMA 5-15P 70" (178cm) long cord	11 lbs (5 kgs)
ESH-36	36 x 6 x 2-7/16 (915x 153 x 67)	120V-50/60Hz, 750W, 6.3A		15.4 lbs (7 kgs)
ESH-48	48 x 6 x 2-7/16 (1220x 153 x 67)	120V-50/60Hz, 1000W, 8.3A		17.6 lbs (8 kgs)
ESH-60	60 x 6 x 2-7/16 (1524x 153 x 67)	120V-50/60Hz, 1400W, 12A		22 lbs (10 kgs)
ESH-72	72 x 6 x 2-7/16 (1829x 153 x 67)	120V-50/60Hz, 1800W, 15A		24.3 lbs (11 kgs)

ITEM	DESCRIPTION	UOM	CASE
ESH-24	24"L	Set	1
ESH-36	36"L	Set	1
ESH-48	48"L	Set	1
ESH-60	60"L	Set	1
ESH-72	72"L	Set	1

### FREESTANDING ELECTRIC STRIP HEATER

- ◆ Heavy-duty steel stand with powder-coated painted exterior and rust resistant interior coating
- ◆ Stand adjusts to three heights above work surface to control heat intensity



ESH-1-HB

ITEM	OVERALL DIMENSIONS L" X D" (mm)	ADJUSTABLE HEIGHT" (mm)	POWER	PLUG & CORD	SHIP WEIGHT
ESH-1	26-1/8 x 14-1/4 (664 x 362)	18 (457mm)	120V-50/60Hz, 500W, 4.2A	NEMA 5-15P 70" (178cm) long cord	6.61 lbs (3 kgs)
		20-3/8 (524mm)			
		22-7/8 (581mm)			
	STRIP HEATER ONLY L" X D" X H" (mm)				
	24-1/8 x 6 x 2-7/16 (616 x 153 x 67)				

ITEM	DESCRIPTION	UOM	CASE
ESH-1	Electric Strip Heater, Steel	Set	1
ESH-1-HB	Hanging Bracket for ESH-1	Each	1



## UNIVERSAL DUMP STATION PAN HOLDERS

### UNIVERSAL DUMP STATION PAN HOLDERS

- ◆ Utilize with heat lamps for cohesive presentation
- ◆ Accommodates 2-1/2" and 4" deep pans

ITEM	DESCRIPTION	UOM	CASE
EHL-PH-B	Black, Fits EHL-3C	Each	1/6
EHL-PH-G	Gray, Fits ESH-1, EHL-2 & EHL-2C	Each	1/6



EHL-PH-B



EHL-PH-G

Compatible with Winco heat lamps



## HEAT LAMPS

Maintain ideal serving temperatures to keep prepared food warm and appetizing under these infrared, twin-bulb heat lamps, featuring maximum adjustability, improved countertop stability and an easy-to-clean, scratch-resistant finish.

- ◆ Compatible with most standard-size food trays
- ◆ Heavy-duty frame with 13 gauge aluminum bulb hoods and frame
- ◆ Two (2) clear, infrared shatter-resistant 250W/120V bulbs included



EHL-3C



EHL-2C

### 3-POSITION ELECTRIC STEEL TUBING HEAT LAMPS

- ◆ Easy-clean, durable, scratch-resistant electrostatic powder-coated finished hoods and frame
- ◆ 3-position adjustable height to control heat intensity

OVERALL DIMENSIONS L" X D" (mm)	ADJUSTABLE HEIGHT* (mm)	POWER	PLUG & CORD	SHIP WEIGHT
19-1/2 x 22-1/2 (495 x 571)	23-5/8 (600mm) 26-1/8 (664mm) 28-5/8 (727mm)	120V-50/60Hz, 500W, 4.2A	NEMA 5-15P 70" (178cm) long cord	6.6 lbs (3 kgs)
BASE DIMENSIONS L" X D" (mm)				
18 x 14 (457 x 356)				

ITEM	DESCRIPTION	UOM	CASE
EHL-3C	3-Position Heat Lamp, Black	Set	1
EHL-2C	3-Position Heat Lamp, Gray	Set	1

Heat lamps include 2 clear, infrared shatter-resistant 250W/120V bulbs

### 4-POSITION ELECTRIC ALUMINUM TUBING HEAT LAMP

- ◆ 14 gauge heavy-duty aluminum tubing frame
- ◆ Easy-clean brushed aluminum finish
- ◆ 4-position adjustable height to control heat intensity

OVERALL DIMENSIONS L" X D" (mm)	ADJUSTABLE HEIGHT* (mm)	POWER	PLUG & CORD	SHIP WEIGHT
19-1/2 x 22-1/2 (495 x 571)	29-3/8 (746mm) 27-1/2 (699mm) 25-1/2 (648mm) 23-3/4 (603mm)	120V-50/60Hz, 500W, 4.2A	NEMA 5-15P 70" (178cm) long cord	7.5 lbs (3.45 kgs)
BASE DIMENSIONS L" X D" (mm)				
16-1/4 x 14-1/4 (413 x 362)				

ITEM	DESCRIPTION	UOM	CASE
EHL-2	4-Position Heat Lamp, Aluminum	Set	1



EHL-2

### INFRARED SHATTER-RESISTANT BULBS FOR HEAT LAMPS INFRARED R40 BULBS

- ◆ Shatter-resistant infrared 250W/120V bulbs
- ◆ R40 bulb with medium E26 base
- ◆ Up to 6,000 hours burn time
- ◆ For commercial food-operations only

ITEM	DESCRIPTION	UOM	CASE
EHL-BR	Red	Each	1/12
EHL-BW	Clear	Each	1/12



Retail Box Design



EHL-BW



EHL-BR



**winco**  
**SPECTRUM**  
 COUNTERTOP INDUCTION COOKERS



EICS-SERIES

Compatible with induction-ready cookware

**EICS-18**  
 For U.S. only

**EICS-18C**  
**EICS-34**  
 For U.S. and Canada

**COUNTERTOP ELECTRIC INDUCTION COOKERS**

Safer than traditional gas or electric resistance burners, induction cooktops use magnetism to rapidly heat up induction cookware, which in turn heats up food. The ideal choice for tableside, catering and buffet-line cooking, induction cooktops are faster and more efficient than installed gas stovetops.

- ◆ Stainless steel body construction
- ◆ Compact, easy-to-clean, portable
- ◆ Easy to use digitally controlled wattage and temperature from warming to cooking for optimal cooking efficiency, control and speed
- ◆ High-impact and high-heat resistant 11-13/16" x 11-13/16" (299mm x 299mm) glass-ceramic cooking surface
- ◆ Accommodates pan sizes between 4-1/2" (114 mm) to 10-1/2" (267mm)
- ◆ Small-article and pan detection
- ◆ Timer up to 150 min (2-1/2 hours)
- ◆ Auto safety shut-off

Heat Efficiency Comparison

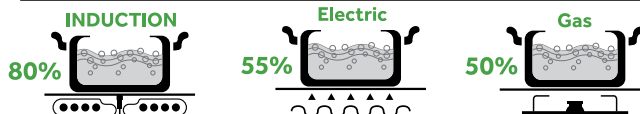

ITEM	OVERALL DIMENSIONS L" X D" X H" (mm)	POWER	PLUG	SHIP WEIGHT
EICS-18	14- <sup>3</sup> / <sub>16</sub> x 18- <sup>1</sup> / <sub>8</sub> x 5- <sup>1</sup> / <sub>8</sub> (360 x 460 x 129)	120V~60Hz, 1800W, 15A	NEMA 5-15P	37.5 lbs (17 kgs)
EICS-18C		120V~60Hz, 1800W, 15A	NEMA 5-20P	
EICS-34		240V~60Hz, 3400W, 14A	NEMA 6-20P	

ITEM	DESCRIPTION	UOM	CASE
EICS-18	US	Set	1/2
EICS-18C	US and Canada	Set	1/2
EICS-34	US and Canada	Set	1/2

**ECONOMY INDUCTION COOKER**

Low profile



**EIC-400E**  
 For U.S. only

**ECONOMY COUNTERTOP ELECTRIC INDUCTION COOKER**

- ◆ Up to 1800 watts of continuous heat to cook everything from a low simmer to a rolling boil
- ◆ Easy-touch controls with adjustable power levels (1-10)
- ◆ Ceramic glass surface with small-article and pan detection, 4-3/4"-10-1/4" induction cookware
- ◆ Durable stainless steel and plastic body construction
- ◆ Timer up to 180 min. (3 Hours)

OVERALL DIMENSIONS L" x D" x H" (mm)	POWER	PLUG	SHIP WEIGHT
11- <sup>3</sup> / <sub>4</sub> x 15- <sup>3</sup> / <sub>4</sub> x 2- <sup>3</sup> / <sub>4</sub> (299 x 400 x 70)	120V~60Hz, 1800W, 15A	NEMA 1-15P	13.3 lbs (6 kgs)

ITEM	DESCRIPTION	UOM	CASE
EIC-400E	Induction Cooker	Each	1/4



## DROP-IN ELECTRIC INDUCTION COOKERS

Safer than traditional gas or electric resistance burners, induction cooktops use magnetism to rapidly heat up induction cookware, which in turn heats up food. The drop-in induction cookers install directly into the countertop for a built-in, streamlined presentation. Ideal for tableside, catering or buffet-line cooking.

- ◆ Powder-coated steel body construction
- ◆ Compact drop-in-counter design that can be flush, recessed, or mounted with optional trim ring
- ◆ Easy to use digital control with ten (10) power wattage levels from warming to cooking for optimal cooking efficiency, control and speed
- ◆ Remote control panel provided with 36" (915mm) quick-connect cord
- ◆ High-impact and high-heat resistant 11-13/16" x 11-13/16" (299mm x 299mm) glass-ceramic cooking surface
- ◆ Accommodates pan sizes between 4-1/2" (114 mm) to 10-1/2" (267mm)
- ◆ Small-article and pan detection
- ◆ Timer up to 150 min (2-1/2 hours)
- ◆ Auto safety shut-off

ITEM	OVERALL DIMENSIONS L" X D" X H" (mm)	POWER	PLUG	SHIP WEIGHT
EIDS-18	12- <sup>3</sup> / <sub>16</sub> " x 13- <sup>7</sup> / <sub>16</sub> " x 3- <sup>7</sup> / <sub>16</sub> " (320 x 340 x 98)	120V-60Hz, 1800W, 15A	NEMA 5-15P	27.7 lbs (12.6 kgs)
EIDS-18C		120V-60Hz, 1800W, 15A	NEMA 5-20P	
EIDS-34		240V-60Hz, 3400W, 14A	NEMA 6-20P	

ITEM	DESCRIPTION	UOM	CASE
EIDS-18	US	Set	1/2
EIDS-18C	US and Canada	Set	1/2
EIDS-34	US and Canada	Set	1/2

## winco® SPECTRUM™ DROP-IN INDUCTION COOKERS



EIDS-SERIES



Control panel mounts to front of counter where drop-in cooker is installed



Drop-in induction cooker mounted in counter

EIDS-18  
For U.S. only

EIDS-18C  
EIDS-34  
For U.S. and Canada

## TRIM RING FOR DROP-IN INDUCTION COOKERS

For a sleek look, install the drop-in induction cookers with this additional trim ring to protect the glass edges and hide the countertop cutout.

ITEM	DESCRIPTION	UOM	CASE
EIDS-TR	Stainless Steel Trim Ring	Each	1



EIDS-TR

## PORTABLE BUTANE GAS STOVE

This portable and compact butane gas stove is great for camping, outdoor parties or catered events.

- ◆ Single, top-quality solid brass burner, built-in pot support and wide base for stability
- ◆ Manually adjustable heat range with up to 9,500 BTU of power
- ◆ Comes with a black impact-resistant hard plastic carrying case for easy transport
- ◆ Automatic gas shut-off safety feature
- ◆ Uses standard 8 oz Butane DOT-2P canister (sold separately)

OVERALL DIMENSIONS L" x D" x H" (mm)	POWER	SHIP WEIGHT
13- <sup>3</sup> / <sub>16</sub> " x 10- <sup>3</sup> / <sub>16</sub> " x 4- <sup>1</sup> / <sub>4</sub> " (340 x 273 x 108)	9500 BTUs	5.2 lbs (2.4 kgs)

ITEM	DESCRIPTION	UOM	CASE
PGS-1K	Portable Gas Stove w/Case, Black, 9500 BTUs, Brass Burner	Each	1/6

## BUTANE GAS STOVE



Superior brass burner



Fits standard Butane canister

PGS-1K

**winco**  
**SPECTRUM**  
IMMERSION CIRCULATORS

**NEW**



**CE** **IPX7**  
Waterproof  
-1m  
**ETL** **NSF**  
Intertek

**IPX7**  
WATERPROOF  
-1m

ESVI-1800

Refer to Food Storage & Poly Pans for full range of containers



**ETL** **ETL**  
Intertek Intertek

ESVI-1

Get cooking with the Spectrum line of sous vide equipment. With precise temperature control and by reducing heat fluctuations, food retains moisture, nutrition, and flavor for perfect results every time.

- ◆ Precise temperature accuracy: +1°F (0.5°C)
- ◆ Temperature range: 41°F to 210°F (5°-99°C)
- ◆ Timer setting range: 5 minutes to 99 hours
- ◆ LED display: Optional °F / °C, with last temperature and time memory when turned on
- ◆ Maximum volume capacity: 7.9 gallons (30L)

**HEAVY-DUTY ELECTRIC IMMERSION CIRCULATOR**

- ◆ Stainless steel construction
- ◆ Easy to use solid state digital control panel
- ◆ IPX7 Waterproof up to -1 meter for 30 minutes
- ◆ High wattage for faster heating and recovery
- ◆ Low water level detection and alarm
- ◆ Quick release fastening screw for fast cleaning

OVERALL DIMENSIONS L" X D" X H" (mm)	POWER	PLUG	SHIP WEIGHT
8-7/8 x 7-1/2 x 13 (174 x 112 x 328)	110-120V~60Hz, 1800W, 15A	NEMA 5-15P NEMA 5-20P (Canada)	7.28 lbs 3.3 kgs

ITEM	DESCRIPTION	UOM	CASE
ESVI-1800	Heavy-Duty Immersion Circulator	Each	1

**ELECTRIC IMMERSION CIRCULATOR**

- ◆ Attached clamp adjusts to fit over container

OVERALL DIMENSIONS L" X D" X H" (mm)	POWER	PLUG	SHIP WEIGHT
3-1/16 x 6-5/16 x 12-7/16 (94 x 167 x 326)	110-120V~60Hz, 900W, 7.5A	NEMA 5-15P	4.4 lbs (2 kgs)

ITEM	DESCRIPTION	UOM	CASE
ESVI-1	Immersion Circulator	Set	1/6

**ELECTRIC THERMAL CIRCULATOR**

- ◆ Wire clip on side conveniently holds lid when open
- ◆ Built-in faucet and drain for easy water removal
- ◆ Included tray with 8 slots for cooking multiple vacuum-sealed portions
- ◆ Maximum volume capacity: 7.4 gallons (28L)

**CONSISTENT  
MORE NUTRITION  
MORE FLAVOR  
RESULTS**

**winco**  
**SPECTRUM**  
THERMAL CIRCULATOR

OVERALL DIMENSIONS L" X D" X H" (mm)	POWER	PLUG	SHIP WEIGHT
22-1/2 x 17-7/16 x 12-3/16 (571 x 442 x 308)	110-120V~60Hz, 1800W, 15A	NEMA 5-15P	18.7 lbs (8.5 kgs)

ITEM	DESCRIPTION	UOM	CASE
ESVC-28	Thermal Circulator	Set	1
ESVC-P17	NEMA 5-20P Cord/Plug (Canada)	Each	1



**ETL** **ETL**  
Intertek Intertek

ESVC-28



Wire clip holds lid



Sectioned tray

### ELECTRIC VACUUM SEALER

- ◆ Compact design with large 3-gallon capacity vacuum chamber
- ◆ Dry vacuum pump and easy-to-use touch controls with adjustable vacuum & seal times, or instant-seal function
- ◆ Stainless steel body construction
- ◆ Heavy-duty transparent lid; dome adds to inner chamber height allowing larger items to fit for sealing

OVERALL DIMENSIONS L" X D" X H" (mm)	CHAMBER DIMENSIONS L" X D" X H" (mm)	POWER	PLUG	SHIP WEIGHT
14- <sup>3</sup> / <sub>16</sub> x 16- <sup>3</sup> / <sub>4</sub> x 15- <sup>1</sup> / <sub>4</sub> (359 x 425 x 388)	12 x 13- <sup>7</sup> / <sub>16</sub> x 5- <sup>1</sup> / <sub>2</sub> (300 x 350 x 133)	110-120- 60Hz, 630W, 5.25A	NEMA 5-15P	59.7 lbs (27.1 kgs)
SEAL BAR	SEAL WIRE			
11-1/2" (295mm)	<sup>7</sup> / <sub>16</sub> " (3.5mm)			

ITEM	DESCRIPTION	UOM	CASE
EVPM-12	Vacuum Sealer	Set	1
EVPM-P1	Seal Bar Assembly	Each	1

## winco® SPECTRUM™ VACUUM SEALER



EVPM-12



11-1/2" seal bar with bag clamp

### 16" MANUAL IMPULSE BAG SEALER

- ◆ Seals fast, in 0.2 to 3 seconds
- ◆ Compatible with rolled, embossed, flat or zipper vacuum bags with a thickness up to 1/32" (0.5mm)
- ◆ Adjustable timer with indicator light when seal is ready
- ◆ No warm-up time for on-demand sealing
- ◆ Durable aluminum and iron construction

ITEM	OVERALL DIMENSIONS L" X D" X H" (mm)	POWER	PLUG	SHIP WEIGHT
EBS-400M	20- <sup>7</sup> / <sub>16</sub> x 3- <sup>5</sup> / <sub>16</sub> x 12 (530 x 92 x 305)	120V-50/60Hz, 480W, 4A	NEMA 5-15P	15 lbs (6.8 kgs)
EBS-400M-I	SEAL BAR	SEAL WIRE		
	15-3/4" (400mm)	1/8" (3mm)	220V-50/60Hz, 480W, 2.2A	CEE 7/7

ITEM	DESCRIPTION	UOM	CASE
EBS-400M	Impulse Bag Sealer	Set	1/10
EBS-400M-I	Impulse Bag Sealer, International	Set	1/10
EBS-MP10	Seal Wire	Each	1

## winco® SPECTRUM™ IMPULSE BAG SEALER



EBS-SERIES

### SOUS VIDE ACCESSORIES

ITEM	DESCRIPTION	UOM	CASE
ESV-BH	Multi Ring Bag Stand	Each	1/4
ESV-IB	Insulation Balls, 100-Pcs/Pk	Pack	1/48
EVVPB-0610	Vacuum Sealer Bags, 6" x 8"	Pack	12
EVVPB-0812	Vacuum Sealer Bags, 8" x 12"	Pack	12

## winco® SPECTRUM™ SOUS VIDE ACCESSORIES



ESV-IB

ESVI-1 with ESV-IB insulation balls, to reduce evaporation and hold heat in



Bag stand conveniently holds various sizes of vacuum bags open for easy filling

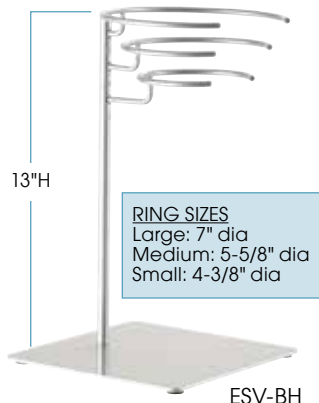

13" H

RING SIZES  
Large: 7" dia  
Medium: 5-5/8" dia  
Small: 4-3/8" dia

ESV-BH

### Boil-In VACUUM SEALER BAGS



EVVPB-0812



EVVPB-0610





## BELGIAN WAFFLE MAKER



7" Dia fixed non-stick plates

UP TO  
**35**  
WAFFLES PER HOUR



## ELECTRIC BELGIAN WAFFLE MAKER

Cook up thick, fluffy waffles with deep divots, perfect for cradling butter, syrup, fruit, and more.

- ◆ Produces up to 35, 1-inch thick waffles per hour
- ◆ Non-stick cooking plates for quick release, easy-to-clean
- ◆ Audible signal alerts when temperature reached, and again when waffle is ready
- ◆ Rotates 180° to evenly distribute batter for perfect waffles every time
- ◆ Space-saving, compact design

OVERALL DIMENSIONS L" x D" x H" (mm)	POWER	PLUG	SHIP WEIGHT
10" x 17-3/4" x 12" (255 x 450 x 305)	120V ~ 50/60Hz, 1000W	NEMA 5-15P	26 lbs (11.8kgs)

ITEM	DESCRIPTION	UOM	CASE
BWM-07	Single Waffle Baker	Each	1

## winco® SPECTRUM™ COUNTERTOP CONVEYOR TOASTERS



300  
OR  
700  
SLICES  
PER HOUR



ECT-SERIES

## ELECTRIC CONVEYOR TOASTERS

The ideal choice for serving perfectly toasted breads, bagels, small pizzas, and similar dough-based products. Easy-to-operate, conveyor toasters keep pace with the busiest kitchens and buffets.

- ◆ Heavy-duty all stainless steel "Cool-Touch" exterior
- ◆ Large 2-1/2" high feeder opening with a 10-3/8" (2 slice) wide conveyor accepts over-sized bagels and Texas toast
- ◆ Rounded, extra-wide curved return chute prevents larger foods items from getting caught
- ◆ Variable conveyor-speed dial control for optimal doneness
- ◆ Choose between independent or dual-heating elements for added flexibility
- ◆ Energy Saver hold mode saves up to 75 percent energy during slow periods when unit is not in use and allows quick recovery to temperature
- ◆ Removable crumb tray
- ◆ Adjustable legs with non-skid foot for stability

MODEL	OVERALL DIMENSIONS L" x D" x H" (mm)	POWER	PLUG	SHIP WEIGHT
ECT-300	14-5/8" x 16-7/16" x 16-3/8" (370 x 420 x 415)	120V- 50/60Hz, 1700W, 14.16A	NEMA 5-15P NEMA 5-20P (Canada)	44.5 lbs (20.2 kgs)
ECT-700		208/240V- 50/60Hz, 1800/2400W, 8.6/10A	NEMA 6-15P	

ITEM	DESCRIPTION	UOM	CASE
ECT-300	300 Slices per Hour	Set	1
ECT-700	700 Slices per Hour	Set	1
ECT300-P8	NEMA 5-20P Cord for ECT-300	Each	1

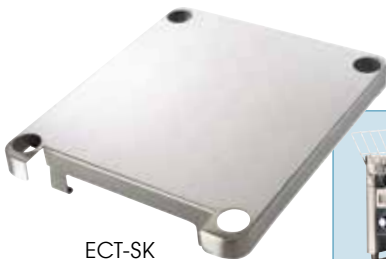

ECT-SK



2 vertically stacked conveyor toaster units

## STACKING KIT FOR CONVEYOR TOASTERS

- ◆ Save on counter space while maximizing productivity
- ◆ Toast multiple varieties simultaneously
- ◆ Durable stainless steel construction
- ◆ Designed to vertically stack 2 ECT toasters

ITEM	DESCRIPTION	UOM	CASE
ECT-SK	Stacking Kit	Each	1/6



Stacking kit shown on conveyor toaster

**ELECTRIC COUNTERTOP CONVECTION OVENS**

- ◆ Stainless steel construction
- ◆ Heat settings range from 150°F to 500°F (65°C to 260°C)
- ◆ Built-in 120 minute timer with "Stay On" feature
- ◆ Dual pane tempered glass door
- ◆ Spacious interior includes 3 chrome wire shelves
- ◆ Whisper quiet circulation for even heating

ITEM	OVERALL DIMENSIONS L" x D" x H" (mm)	INNER DIMENSIONS L" x D" x H" (mm)	POWER	PLUG	SHIP WEIGHT
ECO-250	18-3/4 x 19-7/8 x 15 (477 x 505 x 381)	14 x 11 x 8-1/2 (356 x 280 x 216)	120V~60Hz, 1440W, 12A	NEMA 5-15P	34.83 lbs (15.8 kgs)
ECO-500	22-1/2 x 22-3/4 x 17-3/4 (572 x 579 x 451)	18-1/2 x 15-1/2 x 10 (470 x 394 x 254)	120V~60Hz, 1600W, 13.3A		39.68 lbs (18 kgs)

ITEM	DESCRIPTION	UOM	CASE
ECO-250	Quarter-Size, 0.8 Cubic Ft	Set	1
ECO-500	Half-Size, 1.5 Cubic Ft	Set	1
ECO-P5-25	Wire Rack for ECO-250	Each	1
ECO-P5-50	Wire Rack for ECO-500	Each	1
ALXP-1310H	Aluminum 1/4-Size Sheet Pan for ECO-250	Each	24
ALXP-1813H	Aluminum 1/2-Size Sheet Pan for ECO-500	Each	12

**COUNTERTOP CONVECTION OVENS**



ECO-500



**MULTI-FUNCTION OVENS (SALAMANDER / BAKER / OVEN)**

- ◆ Adjustable thermostat with wide temperature range of 90°F to 550°F
- ◆ Fully insulated stainless steel construction
- ◆ Independent top & bottom heater switches
- ◆ 60 minute timer with "Stay On" feature
- ◆ Adjustable 3" legs
- ◆ Fits 12" pizza (54012), or 16" pizza (54016)

ITEM	OVERALL DIMENSIONS L" X D" X H" (mm)	POWER	PLUG	SHIP WEIGHT
54012	23 x 17 x 11-1/4 (584 x 432 x 254)	120V~60Hz, 1750W, 14.6A	NEMA 5-15P	40 lbs (18.1 kgs)
54016	27 x 17 x 11-1/4 (686 x 432 x 254)			55 lbs (25 kgs)

ITEM	DESCRIPTION	UOM	CASE
54012	12"x 3" Opening	Set	1
54016	16"x 3" Opening	Set	1



**MULTI-FUNCTION OVENS**



**ELECTRIC COUNTERTOP PIZZA OVEN**

- ◆ Heats up to 600°F (315°C); dual independently controlled heating elements
- ◆ 60-minute timer with bell includes "Stay On" feature
- ◆ Pizza tray handle folds for storage
- ◆ Includes crumb tray
- ◆ Fits up to 12" diameter pizza

OVERALL DIMENSIONS L" x D" x H" (mm)	POWER	PLUG	SHIP WEIGHT
20-7/8 x 14-3/4 x 9-1/4 (530 x 375 x 235)	120V~50/60Hz, 1500W, 12.5A	NEMA 5-15P	26.9 lbs (12.2 kgs)

ITEM	DESCRIPTION	UOM	CASE
EPO-1	Pizza Oven w/Bell Timer and "Stay On" Function	Set	1
EPO-P7	Crumb Tray Knob for EPO-1	Each	1

**PIZZA OVEN**



Fits 12" pizza



**winco**  
**SPECTRUM**  
 STAINLESS STEEL  
 MICROWAVES

The Winco commercial microwaves provide consistent results with frequent and repeated use, essential for quick-serve restaurants, concession stands, prep stations, and more. Attractive, fully stainless steel interior and exterior units are reliable, sturdy and easy-to-clean.



**ELECTRIC TOUCH CONTROL MICROWAVES - 1800 & 2100 WATTS**

- ◆ Stainless steel with glass door and lighted interior provides visibility during operation
- ◆ Large capacity 1.2 cubic feet (34L) accommodates a 14" (356mm) platter
- ◆ 5 power levels for consistent, delicious results
- ◆ Manual time and power option, plus 2X quantity button for multiple portions
- ◆ 10 pre-programmed cooking options, storing up to 100 cooking programs
- ◆ 3-stage cooking with one-touch programming

ITEM	OVERALL DIMENSIONS L" x D" x H" (mm)	POWER	PLUG	SHIP WEIGHT
EMW-1800AT	22-5/8 x 20-3/4 x 14-1/2	208/230V~60Hz, 1800W, 8.6A	NEMA 6-20P	75.6 lbs (34.3 kgs)
EMW-2100BT	(574 x 526 x 368)	208/230V~60Hz, 2100W, 10A		

**UL** **US**  
**LISTED**  
**ETL**  
**Intertek**  
 EMW-1800AT  
 EMW-2100BT

ITEM	DESCRIPTION	UOM	CASE
EMW-1800AT	1800 W	Set	1
EMW-2100BT	2100 W	Set	1

**ELECTRIC MICROWAVES - 1000 WATTS**

- ◆ 1,000 watts of cooking power for quick heating
- ◆ Motor driven bottom antenna for efficient energy distribution and consistent results
- ◆ Engineered for commercial kitchen use
- ◆ Stainless steel interior with bottom ceramic plate
- ◆ Ample 0.9 cubic feet (25 L) oven capacity
- ◆ Accommodates 12" (30.5 cm) diameter platter
- ◆ Backlit LED display
- ◆ Interior oven light



**ELECTRIC TOUCH CONTROL MICROWAVE**

- ◆ 3 customizable key-beep volumes

OVERALL DIMENSIONS L" x D" x H" (mm)	POWER	PLUG	SHIP WEIGHT
20 1/8 x 17 x 12 1/4 (511 x 432 x 311)	120V~60Hz, 1000W, 12A	NEMA 5-15P	35.7 lbs (16.2 kgs)

**UL** **US**  
**LISTED**  
**ETL**  
**Intertek**  
 EMW-1000ST

ITEM	DESCRIPTION	UOM	CASE
EMW-1000ST	Spectrum Commercial Microwave, Touch, Stainless Steel, 1,000 W	Set	1



**ELECTRIC DIAL CONTROL MICROWAVE**

OVERALL DIMENSIONS L" x D" x H" (mm)	POWER	PLUG	SHIP WEIGHT
20-1/2 x 18 x 12-5/16 (521 x 457 x 313)	120V~60Hz, 1000W, 12A	NEMA 5-15P	44.1 lbs (20 kgs)

**UL** **US**  
**LISTED**  
**ETL**  
**Intertek**  
 EMW-1000SD

ITEM	DESCRIPTION	UOM	CASE
EMW-1000SD	Spectrum Commercial Microwave, Dial, Stainless Steel, 1,000 W	Set	1

**New Item**



**ELECTRIC COUNTERTOP DEEP FRYERS**

Countertop fryers are a great, easy addition to any food service operation. Great for chicken, fries, onion rings, tempura, shrimp, vegetables and more!

- ◆ Commercial fry basket(s) with safe and secure handle
- ◆ Expedient heat-up
- ◆ Removable stainless steel fry well(s) for easy cleaning; fry well cover(s) included
- ◆ Removable power head(s)

**COUNTERTOP DEEP FRYERS**



Cover(s) for well (s) included



EFS-16

**ELECTRIC COUNTERTOP SINGLE WELL DEEP FRYER**

- ◆ 16 lb oil capacity
- ◆ 8 liters = 16 lbs = 2.11 gallons

OVERALL DIMENSIONS L" X D" X H" (mm)	POWER	PLUG	SHIP WEIGHT
11-3/4 x 16 x 13-5/8 (298 x 406 x 346)	120V-50/60Hz, 1750W, 14.6A	NEMA 5-15P	19.9 lbs (9.03 kgs)

ITEM	DESCRIPTION	UOM	CASE
EFS-16	Single Well Fryer	Set	1
EFST-P30	Fry Basket	Each	1

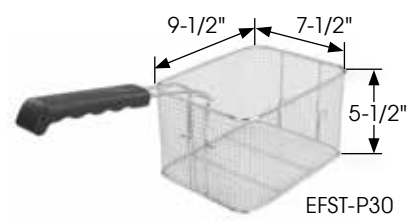

EFST-P30

**ELECTRIC COUNTERTOP TWIN WELL DEEP FRYER**

- ◆ 32 lb oil capacity
- ◆ 2 x 8 liters (16 liters combined) = 32 lbs; total = 4.22 gallons

OVERALL DIMENSIONS L" X D" X H" (mm)	POWER	PLUG	SHIP WEIGHT
21-1/4 x 16 x 13-5/8 (616 x 406 x 346)	120V-50/60Hz, 1750W, 14.6A (x2)	NEMA 5-15P (x2)	34.8 lbs (15.8 kgs)

ITEM	DESCRIPTION	UOM	CASE
EFT-32	Double Well Fryer	Set	1
EFST-P30	Fry Basket	Each	1



EFT-32

Refer to Kitchen Utensils for fryer accessories



Cover(s) for well(s) included

# COUNTERTOP SANDWICH GRILLS

Textured grip handle



ESG-1

## ELECTRIC COUNTERTOP SANDWICH GRILLS

Flat-top grills are great for sandwiches, and widely used for breakfast eggs and meats, flat breads, quesadillas, and more.

- ◆ Stainless steel construction; flat cast iron grill surface
- ◆ Hinged balanced top plate adjusts to food thickness
- ◆ Removable crumb and grease tray
- ◆ Power and ready light(s)
- ◆ Includes steel-bristle brush w/wooden handle for cleaning
- ◆ Adjustable thermostat up to 600°F (315°C)

### ELECTRIC SINGLE FLAT SANDWICH GRILL

OVERALL DIMENSIONS L" X D" X H" (mm)	POWER	PLUG	SHIP WEIGHT
17 x 12 x 8 (432 x 305 x 203)	120V-50/60Hz, 1750W, 15A	NEMA 5-15P	46.6 lbs (21.2) kgs)
GRILL SURFACE L" x D" (mm)			
14 x 9 (356 x 229)			

ITEM	DESCRIPTION	UOM	CASE
ESG-1	Single Grill	Set	1
EPSP-P52S	Handle for ESG-1	Each	1
EPSP-P28	Black Knob w/Red Ring	Each	1
EPSP-P53S	Grease Tray for ESG-1	Each	1
EPSP-P56	Steel Bristle Brush w/Wooden Handle	Each	1

Sturdy hinge



Smooth grilling surface



Easy to use controls



ESG-2

### ELECTRIC DOUBLE FLAT SANDWICH GRILL

OVERALL DIMENSIONS L" X D" X H" (mm)		POWER	PLUG	SHIP WEIGHT
22-1/2 x 12 x 8 (572 x 305 x 203)		120V-50/60Hz, 1750W, 15A (x2)	NEMA 5-15P (x2)	57 lbs (25.9) kgs)
GRILL SURFACE L" x D" (mm)	GRILL PLATES L" x D" (mm)			
19 x 9 (483 x 229)	9 x 9 (229 x 229)			

ITEM	DESCRIPTION	UOM	CASE
ESG-2	Double Grill	Set	1
EPSP-P52D	Handle for ESG-2	Each	1
EPSP-P28	Black Knob w/Red Ring	Each	1
EPSP-P53D	Grease Tray for ESG-2	Each	1
EPSP-P56	Steel Bristle Brush w/Wooden Handle	Each	1

### ELECTRIC COUNTERTOP PANINI GRILLS

This ribbed grill offers versatility and can be used in many types of food service operations, from paninis and wraps, to grilled vegetables or chicken.

- ◆ Stainless steel construction; ribbed cast iron grill surface
- ◆ Hinged balanced top plate adjusts to food thickness
- ◆ Removable crumb and grease tray
- ◆ Power and ready light(s)

### COUNTERTOP PANINI GRILLS



### ELECTRIC SINGLE PANINI GRILL

- ◆ Includes steel-bristle brush w/plastic handle for cleaning
- ◆ Adjustable temperature up to 570°F (298°C)

OVERALL DIMENSIONS L" X D" X H" (mm)	POWER	PLUG	SHIP WEIGHT
16-1/8 x 14-3/4 x 9-3/4 (410 x 375 x 248)	120V-50/60Hz, 1750W, 14.6A	NEMA 5-15P	63.3 lbs (28.7 kgs)
GRILL SURFACE L" x D" (mm) 14 x 12 (356 x 305)			

ITEM	DESCRIPTION	UOM	CASE
EPG-1C	Single Grill	Set	1
EPG-CP8	Steel Brush for EPG-1C	Each	1
EPG-CP3	Grease Tray for EPG-1C	Each	1

### CAST IRON FLAT-TOP GRIDDLE ADAPTOR PLATE

- ◆ Size: 14-3/8" (365mm) x 11-7/8" (302mm)
- ◆ Pre-seasoned heavy-duty cast iron construction
- ◆ 1/4" raised edges collect, contain and direct grease to front trough
- ◆ Ribbed underside nests tightly with panini plate for efficient high-heat transfer

ITEM	DESCRIPTION	UOM	CASE
EPG-RF1C	Cast Iron Flat Top Griddle Plate for EPG-1C	Each	1

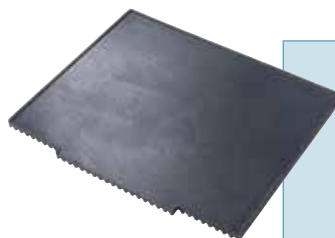

EPG-RF1C

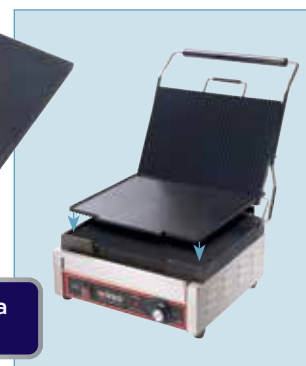

Convert EPG-1C to a flat-top griddle

### ELECTRIC DOUBLE RIBBED PANINI GRILL

- ◆ Includes steel-bristle brush w/wooden handle for cleaning
- ◆ Adjustable thermostat up to 600°F (315°C)

OVERALL DIMENSIONS L" X D" X H" (mm)	POWER	PLUG	SHIP WEIGHT	
22-1/2 x 12 x 8 (572 X 305 X 203)	120V-50/60Hz, 1750W, 15A (x2)	NEMA 5-15P (x2)	64 lbs (29 kgs)	
GRILL SURFACE L" x D" (mm)				GRILL PLATES L" x D" (mm)
19 x 9 (483 x 229)				9 x 9 (229 x 229)

ITEM	DESCRIPTION	UOM	CASE
EPG-2	Double Grill	Set	1
EPG-P52D	Handle for EPG-2	Each	1
EPG-P28	Black Knob w/Red Ring	Each	1
EPG-P53D	Grease Tray for EPG-2	Each	1
EPG-P56	Steel Bristle Brush w/Plastic Handle	Each	1



Ribbed grilling surfaces





**winco**  
**SPECTRUM**  
 PLANETARY MIXERS



EMP-10



EMP-20



EMP-30

**ELECTRIC PLANETARY MIXERS**

Commercial countertop and floor planetary mixers feature gear-driven motors with three speeds, making it an ideal piece of equipment for bakeries, delis, cafés, and other commercial kitchen environments.

- ◆ Heavy-duty die cast iron construction
- ◆ Gear-driven, high torque transmission
- ◆ Large capacity 304 stainless steel bowl with safety guard and interlock bowl lift
- ◆ (3) three fixed mixing speeds
- ◆ Manual resettable thermal overload protection
- ◆ Industry standard #12 attachment hub (EMP-20 & EMP-30)
- ◆ Wire whip, aluminum flat beater, & spiral dough hook attachments included
- ◆ Non-slip rubber feet

ITEM	OVERALL DIMENSIONS L" X D" X H" (mm)	POWER	PLUG	SHIP WEIGHT
EMP-10	15 <sup>-1/8</sup> x 18 x 24 <sup>-1/8</sup> (383 x 456 x 612)	110V 50/60 Hz 750W 1HP 7A	NEMA 5-15P	99.2 lbs (45 kgs)
EMP-20	19 <sup>-7/8</sup> x 21 <sup>-11/16</sup> x 29 <sup>-3/4</sup> (505 x 550 x 735)	110V 50/60 Hz 1100W 1.5HP 10A	NEMA 5-15P	188.5 lbs (85.5 kgs)
EMP-30	23 <sup>-13/16</sup> x 24 <sup>-1/2</sup> x 44 <sup>-13/16</sup> (605 x 620 x 1138)	110V 50/60 Hz 1500W 2HP 14A	NEMA 5-15P	345.1 lbs (156.5 kgs)

ITEM	DESCRIPTION	UOM	CASE
EMP-10	10.5 Qt (10L)	Set	1
EMP-20	21.1 Qt (20L)	Set	1
EMP-30	31.7 Qt (30L)	Set	1

See spec sheet for replacement bowls, wire whips, flat beaters, hooks, and ingredient chutes

**STAINLESS STEEL MIXER STAND WITH MARINE EDGE**

The right mix of durability, functionality, and hygiene to provide a reliable and efficient platform for mixing tasks in commercial kitchens.

- ◆ Top shelf: 16-gauge stainless steel, 900lb capacity
- ◆ Marine top-edge contains spills
- ◆ Bottom shelf: galvanized steel, 700lb capacity
- ◆ Sturdy legs with adjustable non-skid feet
- ◆ Stable support for a heavy mixer with no wobble when operating equipment
- ◆ Optimize space and free up valuable countertops
- ◆ Durable & corrosion-resistant to withstand busy kitchens

ITEM	DESCRIPTION	UOM	CASE
EMT-2424	24"L x 24"W x 24"H	Each	1

AVAILABLE  
SEPT. 2024

NEW



Marine top-edge contains spills



EMT-2424

CE  
 Intertek  
 EMP-SERIES

New Item

**ELECTRIC GRIDDLES**

Spectrum griddles have a wide heating range, from frying eggs on low to cooking burgers with high heat, all on the half-inch thick polished steel grill surface. Independent controls further regulate the heating zones. The extra-tall steel wall backsplash enclosure helps to minimize grease splatters.

- ◆ Solid 1/2" thick polished steel plate for fast heat up and high heat retention
- ◆ Heavy gauge stainless steel body with 3" high backsplash; sides taper back to front
- ◆ Large-volume removable grease drawer with weep hole and baffle
- ◆ Heavy duty, stainless steel adjustable legs for stability
- ◆ Compatible for 1-phase or 3-phase operation (field convertible EGD-24M & EGD-36M)
- ◆ 3-1/4" full width grease trough

ITEM	OVERALL DIMENSIONS L" X D" X H" (mm)	POWER	PLUG	SHIP WEIGHT
EGD-16M*	16 x 19-1/8 x 12-7/8 (406 x 486 x 327)	120V 50/60 Hz 1750W 14.6A	NEMA 5-15P NEMA 5-20P (Canada)	53 lbs (24 kgs)
EGD-24M**	24 x 21-3/8 x 12-7/8 (610 x 551 x 327)	208/240V- 50/60 Hz, 4200/5600W, 20.2/23.4A, 1-phase	NEMA L6-30P	116.84 lbs (53 kg)
EGD-36M**	36 x 21-3/8 x 12-7/8 (913 x 551 x 327)	208/240V- 50/60 Hz, 6300/8400W, 30.29/35A, 1-phase	Field-wired by others	159.61 lbs (72.4 kg)

\*Cooking surface depth 15-1/8" (384mm) \*\*Cooking surface depth 16-1/2" (419mm)

ITEM	DESCRIPTION	UOM	CASE
EGD-16M	16" Griddle, 1 Heat Zone	Set	1
EGD-24M	24" Griddle, 2 Heat Zones	Set	1
EGD-36M	36" Griddle, 3 Heat Zones	Set	1
EGD-MP6	Replacement Knob	Each	1
EGD-MP19	NEMA 5-20P cord for EGD-16M	Each	1

**winco**  
**SPECTRUM**  
COUNTERTOP ELECTRIC GRIDDLES

**Small footprint, big impact**



EGD-16M



EGD-24M



EGD-36M

Adjustable legs



EGD-SERIES

**GAS STOCK POT STOVE, FLOOR USE**

Designed for the kitchen that has limited space and requires a low work height for large pots. This unit is equipped with a high-performance triple-ring burner, heavy duty single-piece cast iron top grate, removable crumb tray and a storage area below the control panel. Includes an LP conversion kit.

- ◆ High performance single (1) grate with three (3) concentric ring burners for a total output of 80,000 BTUH
- ◆ Dual infinite heat controls
- ◆ Stainless steel body, legs and drip pan
- ◆ Heavy duty cast iron grate
- ◆ Standing pilot ignition system with stainless steel pilots and pilot tubes
- ◆ 3/4" rear gas connection with regulator
- ◆ Convenient storage area in cabinet
- ◆ Conversion kit allows the use of propane or natural gas

ITEM	DESCRIPTION	UOM	CASE
NGSP-1	18" Gas Stock Pot Stove	Set	1
NG-Knob	Replacement Metal Knob	Each	1

**winco**  
**SPECTRUM**  
GAS STOCK POT STOVE

2 infinite heat controls



For use on the floor

# OF BURNERS	# OF RINGS	BTU/PER NAT/LP	TOTAL BTU/HR	PRESSURE IN. W.C.	DIMENSIONS* L" x D" x H" (mm)	GRATE SURFACE L" x D" (mm)	SHIP WEIGHT
2	3	40,000	80,000	5 / 10	18 x 21-3/8 x 25 3/4 (455 x 543 x 653)	17 3/4 x 21-3/8 (450 x 543)	132 lbs (60 kgs)

Note: Depths do not include gas inlet pipe, located at rear of the unit.



NGSP-1

**winco**  
**SPECTRUM**  
 COUNTERTOP  
 GAS CHARBROILERS

**GAS CHARBROILERS, NATURAL / LP**

The durable Spectrum stainless steel charbroilers feature a cool-touch front plate rail that runs the full length. These units are equipped with infinite heat controls, high-performance burners, heavy-duty cast iron top grates, and removable grease tray(s).



NGCB-24R



NGCB-36R



NGCB-48R

- ◆ High performance burners, each with output of 35,000 BTUH
- ◆ Infinite heat controls
- ◆ Stainless steel 10 gauge radiant burner covers; field-convertible briquette rock kits sold separately
- ◆ Stainless steel insulated double-wall body, grease tray and adjustable legs (4" to 6"); non-skid feet
- ◆ Heavy-duty reversible cast iron grate, adjusts to three (3) height positions
- ◆ 5" cool-touch stainless steel front plate rail provides safety and knob protection
- ◆ 3-1/2" full-width grease trough
- ◆ Standing pilot ignition system with stainless steel pilots and pilot tubes, one per burner
- ◆ 3/4" rear gas connection with regulator
- ◆ Conversion kit allows the use of propane or natural gas

ITEM	DESCRIPTION	UOM	CASE
NGCB-24R	24" Gas Broiler, 2 Burners	Set	1
NGCB-36R	36" Gas Broiler, 3 Burners	Set	1
NGCB-48R	48" Gas Broiler, 4 Burners	Set	1
NG-Knob	Replacement Metal Knob	Each	1



Adjustable legs



NGCB-SERIES

ITEM	# OF BURNERS	TOTAL BTU/HR	PRESSURE IN. W.C.	DIMENSIONS* L" x D" x H" (mm)	GRATE SURFACE L" x D" (mm)	SHIP WEIGHT
NGCB-24R	2	70,000	4" / 10"	24 x 34 <sup>-7/16</sup> x 15 <sup>-1/2</sup> (610 x 875 x 394)	24 x 20 (610 x 508)	154 lbs (70 kg)
NGCB-36R	3	105,000	4" / 10"	36 x 34 <sup>-7/16</sup> x 15 <sup>-1/2</sup> (915 x 875 x 394)	36 x 20 (915 x 508)	220 lbs (100 kg)
NGCB-48R	4	140,000	4" / 10"	48 x 34 <sup>-7/16</sup> x 15 <sup>-1/2</sup> (1220 x 875 x 394)	48 x 20 (1220 x 508)	277 lbs (126 kg)

\*includes gas inlet pipe at rear



NGCB-P11-2/3/4



NGCB-P7

**GAS CHARBROILER ACCESSORIES - FIELD CONVERTIBLE**

ITEM	DESCRIPTION	UOM	CASE
NGCB-P11-2	24" Briquette Rock Kit	Pack	1
NGCB-P11-3	36" Briquette Rock Kit	Pack	1
NGCB-P11-4	48" Briquette Rock Kit	Pack	1
NGCB-P7	Replacement Briquettes (24/bag)	Bag	1



## GAS GRIDDLES, NATURAL / LP

Spectrum griddles are designed with durable stainless steel construction and cool-touch front plate rail that runs the full length. These units are equipped with infinite heat controls, high-performance burners, and removable grease drawer.

- ◆ High performance burners, each with output of 30,000 BTUH
- ◆ Infinite heat controls
- ◆ 5" wide cool-touch stainless steel front plate rail provides safety and knob protection
- ◆ Stainless steel insulated double-wall body, grease tray and adjustable legs (4" to 6"); non-skid feet
- ◆ 3/4" polished steel griddle plate with side and back splash guard
- ◆ 3-1/2" full width grease trough
- ◆ Standing pilot ignition system with stainless steel pilots and pilot tubes, one per burner
- ◆ 3/4" rear gas connection with regulator
- ◆ Conversion kit allows the use of propane or natural gas

ITEM	DESCRIPTION	UOM	CASE
NGGD-24M	24" Gas Griddle, 2 Heat Zones	Set	1
NGGD-36M	36" Gas Griddle, 3 Heat Zones	Set	1
NGGD-48M	48" Gas Griddle, 4 Heat Zones	Set	1
NG-Knob	Replacement Metal Knob	Each	1

# winco® SPECTRUM™ COUNTERTOP GAS GRIDDLES



ITEM	# OF BURNERS	TOTAL BTU/HR	PRESSURE IN. W.C.	DIMENSIONS* L" x D" x H" (mm)	GRIDDLE SURFACE L" x D" (mm)	SHIP WEIGHT
NGGD-24M	2	60,000	4" / 10"	24" x 34-7/16" x 15-1/2" (610 x 950 x 394)	24" x 20-3/4" (610 x 527)	196 lbs (89 kg)
NGGD-36M	3	90,000		36" x 34-7/16" x 15-1/2" (915 x 950 x 394)	36" x 20-3/4" (915 x 527)	284 lbs (129 kg)
NGGD-48M	4	120,000		48" x 34-7/16" x 15-1/2" (1219 x 950 x 394)	48" x 20-3/4" (1219 x 527)	355 lbs (161 kg)

\*includes gas inlet pipe at rear



NGGD-SERIES



Adjustable legs

**winco**  
**SPECTRUM**  
 COUNTERTOP  
 GAS HOT PLATES

**GAS HOT PLATES, NATURAL / LP**

Spectrum hot plates are designed with durable stainless steel construction and a cool-touch front plate rail that runs the full length. These units are equipped with infinite heat controls, high-performance burners, heavy-duty cast iron top grates, and removable grease/drip pan.

- ◆ High performance burners, each with output of 25,000 BTUH
- ◆ Infinite heat controls
- ◆ Stainless steel body, removable drip pan, and adjustable legs (4" to 6"); non-skid feet
- ◆ Heavy-duty 12" x 12" cast iron grates
- ◆ 5" wide cool-touch stainless front steel plate rail provides safety and knob protection
- ◆ Standing pilot ignition system with stainless steel pilots and pilot tubes, one per burner
- ◆ 3/4" rear gas connection with regulator
- ◆ Conversion kit allows the use of propane or natural gas



NGHP-2



NGHP-4



NGHP-6

ITEM	DESCRIPTION	UOM	CASE
NGHP-2	12" Hot Plate, 2 Burners	Set	1
NGHP-4	24" Hot Plate, 4 Burners	Set	1
NGHP-6	36" Hot Plate, 6 Burners	Set	1
NG-Knob	Replacement Metal Knob	Each	1



Adjustable legs



NGHP-SERIES

ITEM	# OF BURNERS	TOTAL BTU/HR	PRESSURE IN. W.C.	DIMENSIONS* L" x D" x H" (mm)	GRATE SURFACE L" x D" (mm)	SHIP WEIGHT
NGHP-2	2	50,000	4" / 10"	12 x 34-1/8 x 15 (305 x 87 x 381)	12 x 24 (305 x 610)	79 lbs (36 kgs)
NGHP-4	4	100,000		24 x 34-1/8 x 15 (610 x 87 x 381)	24 x 24 (610 x 610)	132 lbs (60 kgs)
NGHP-6	6	150,000		36 x 34-1/8 x 15 (915 x 87 x 381)	36 x 24 (915 x 610)	198 lbs (90 kgs)

\*includes gas inlet pipe at rear

### STAINLESS STEEL MIXER STAND WITH MARINE EDGE

The right mix of durability, functionality, and hygiene to provide a reliable and efficient platform for mixing tasks in commercial kitchens.

- ◆ Top shelf: 16-gauge stainless steel, 900lb capacity
- ◆ Marine top-edge contains spills
- ◆ Bottom shelf: galvanized steel, 700lb capacity
- ◆ Sturdy legs with adjustable non-skid feet
- ◆ Stable support for a heavy mixer with no wobble when operating equipment
- ◆ Optimize space and free up valuable countertops
- ◆ Durable & corrosion-resistant to withstand busy kitchens

ITEM	DESCRIPTION	UOM	CASE
EMT-2424	24"L x 24"W x 24"H	Each	1



### EQUIPMENT STANDS

← AVAILABLE SEPT. 2024

NEW



EMT-2424

NSF

EMT-2424

### STAINLESS STEEL EQUIPMENT STANDS

Optimize workflow, ensure safety and hygiene, and maximize the efficiency of commercial kitchens and workspaces.

- ◆ Top shelf: 16-gauge stainless steel, 900lb capacity
- ◆ 1-1/2" high raised edges on 3 sides prevent items from slipping off
- ◆ Bottom shelf: galvanized steel, 700lb capacity
- ◆ Sturdy legs with adjustable non-skid feet
- ◆ Easy-clean smooth surfaces promote hygiene and sanitation, reducing risk of cross-contamination to ensure compliance with health & safety regulations
- ◆ Designed to stand at a comfortable height to reduce strain and fatigue for improved productivity and overall well-being.

ITEM	DESCRIPTION	UOM	CASE
ES-2430	24"L x 30"W x 24"H	Each	1
ES-3630	36"L x 30"W x 24"H	Each	1
ES-4830	48"L x 30"W x 24"H	Each	1
ES-6030	60"L x 30"W x 24"H	Each	1

← AVAILABLE SEPT. 2024

NEW



24"

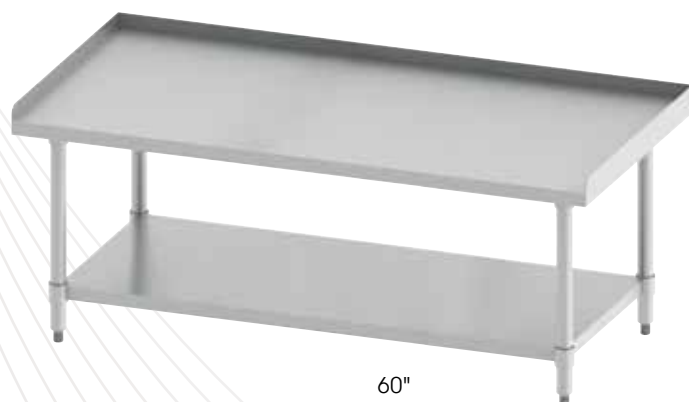

60"



48"

NSF

ES-SERIES

