



HISUN SECTOR CREW 750 DOOR REAR WINDOW

Your enclosure is made of heavy duty fabric that is water repellent and resistant to mildew, ultra-violet rays and abrasion.

Surface Preparation Instructions and Guidelines

Cleaning: To achieve a strong bond between Velcro adhesive and UTV surface, you must clean the surface. Use a mixture of 50% alcohol and 50% water to remove dirt, mud and dust from roll bars and plastic body components. Let dry. Repeat this process 3 times.

The adhesive hook should be applied at a temperature of 70 degrees or above.

Bond between UTV and adhesive hook is dependent upon the amount of adhesive to surface contact development. Firm application pressure develops a better adhesive contact and improves bond strength.

After application, the bond strength increases and approaches the ultimate bond strength after 72 hours. Bond strength build up: 20 min equals 50% bond strength, 1 hour equals 75% bond strength, one day equals 90% bond strength, and 3 days equals 100% bond strength.

More tips for installation.

Two is better than one: We recommend a second person be involved for the installation process. Getting the panel in the correct position takes some pulling and tugging, we find the process runs smoother when there are two people pulling.

Test adhesion: Use a small piece of Velcro, remove backing and adhere to roll bars. Wait 20 minutes, Velcro should already be difficult to remove.

Still having trouble with adhesion: If Velcro is still not adhering to the roll bars, use a piece of hook (rough side of Velcro) to "rough up" the surface of your roll bar. We do not recommend this for the plastic body of your UTV, it will scratch.

Unsure about Velcro placement: With-out removing the white backing, attach the Velcro to your enclosure panel. Hold panel up to the UTV and note the area that the Velcro should attach. You can use the double-sided straps with-out Velcro to help hold up the panel while you remove the white backing and adhere sticky Velcro. We will send extra Velcro that can be used to hold the enclosure to the cab frame for easy notation of Velcro placement.

Attaching panel: Attach the panel top first, then work your way around the panel pulling the tabs and sticking them to the corresponding adhesive Velcro. The Webbing (black trim) of the panel should align to the middle of the roll bar.

Velcro: Velcro is the brand name for hook and loop.

Hook is the rough side. **Loop** is the soft side.

See enclosed Product Care sheet for instructions on how to properly care for your 3 STAR UTV Enclosure.

PAGE	ADHESIVE HOOK	PLACEMENT
2	76-6"	WRAP AROUND ROLLBAR
7	2-8"	DIRECTLY ON THE BODY OF THE SXS
8	2-9"	DIRECTLY ON THE BODY OF THE SXS
10	2-4"	DIRECTLY ON THE BODY OF THE SXS
10	4-3"	DIRECTLY ON THE BODY OF THE SXS
10	2-6"	DIRECTLY ON THE BODY OF THE SXS

PAGE	ADHESIVE HOOK	PLACEMENT
6	1-53"	BEHIND THE BED FOR THE LOWER PORTION OF THE BACK PANEL .
3	6-23"	FOR THE DOOR COVER
3	6-27"	FOR THE DOOR COVER
	1-24"	EXTRA ADHESIVE HOOK

Begin wrapping 6" adhesive hook around the roll bar.



Install adhesive hook on the factory half door.

FRONT DOOR



FRONT DOOR



CUT THESE STRIPS INTO SMALLER STRIPS FOR EASIER INSTALLATION

BACK DOOR



BACK DOOR

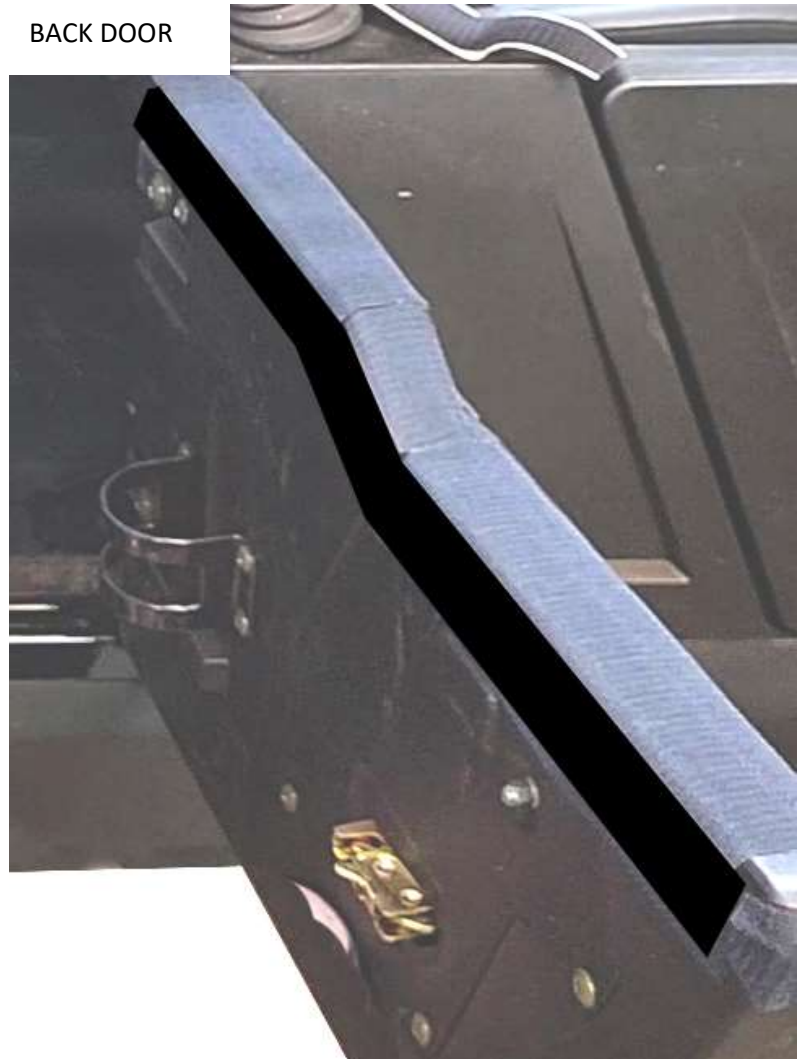

BACK DOOR



23" Front Door Cover

Sewn in loop will attach to the adhesive hook installed on the half door.



The lower half of your door kit will attach to the sewn in hook.

27" Back Door Cover

Sewn on loop will attach to the adhesive hook installed on the half door.



Sewn on hook will attach to the bottom of the half door kit.

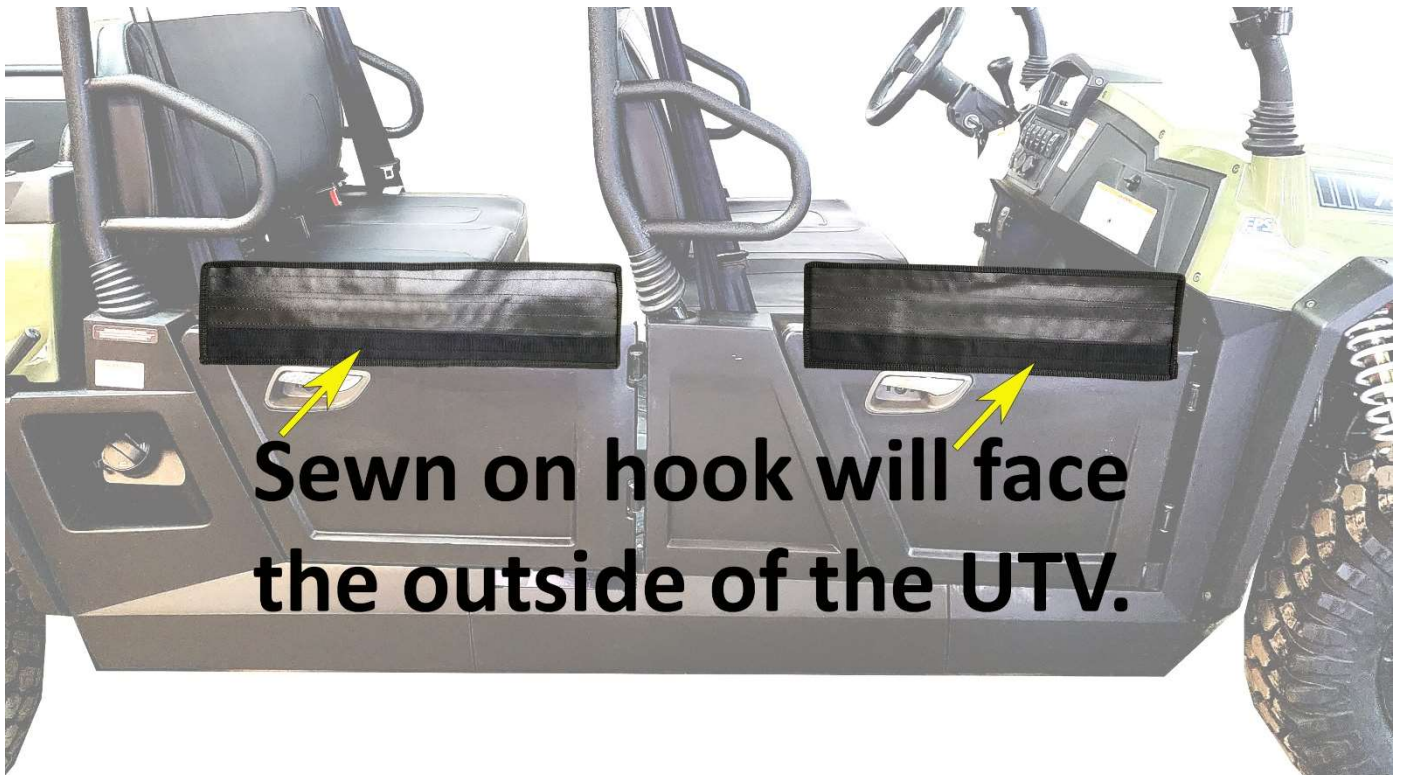



Fold the door cover over the top of the half door and around to the inside of the door, stick loop to adhesive hook.

Connect the buckles and pull the strap tight to keep your cover in place.

Repeat these steps for all door covers.

Install the back panel.

Center the back panel on the rear roll bars.

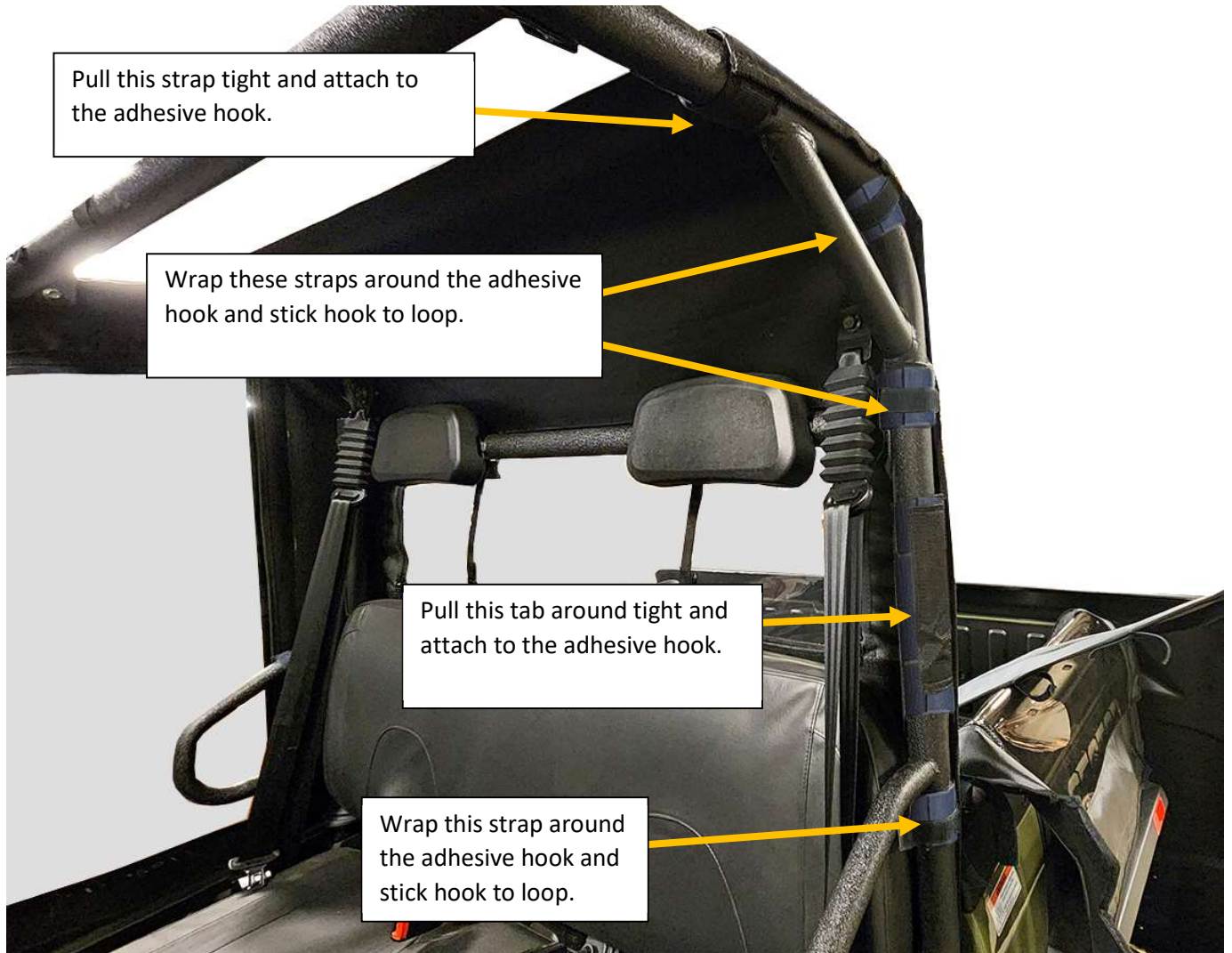

Install the back door frame.

The sewn-on loop on the rear of the back door frame will attach to the hook sewn on the outside of the back panel.



Attach 8" adhesive strip for the lower section of the back frame.

Fold top tab down and attach to the sewn in hook on the back panel.

Set Back Frame on the rear side roll bar.

Wrap tab around and attach to the sewn in hook on the back panel.

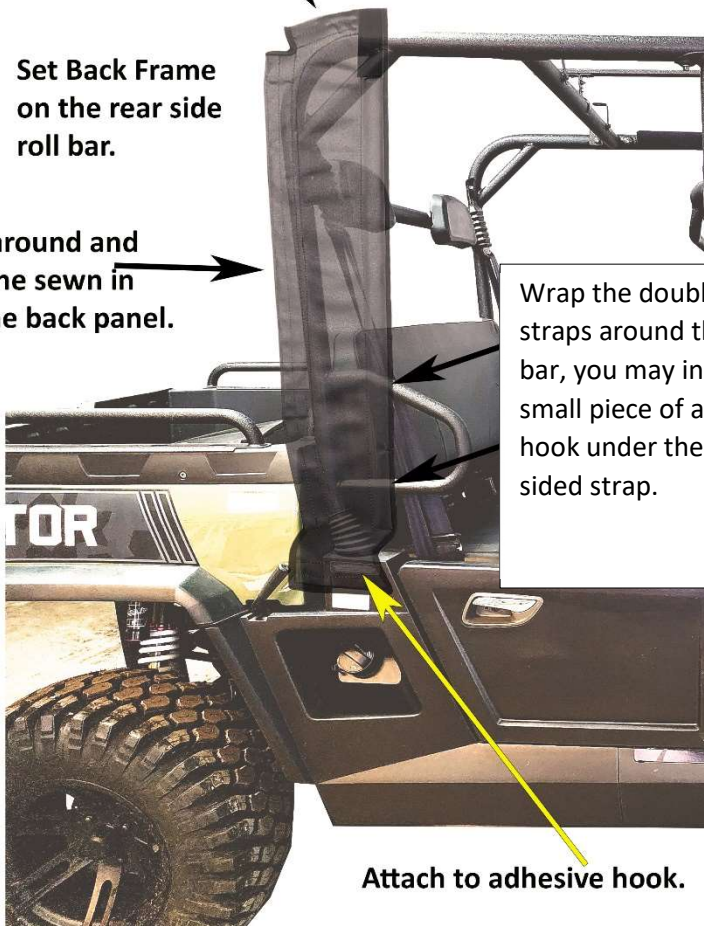

Wrap the double-sided straps around the grab bar, you may install a small piece of adhesive hook under the double-sided strap.



Attach to adhesive hook.

Install the back door.

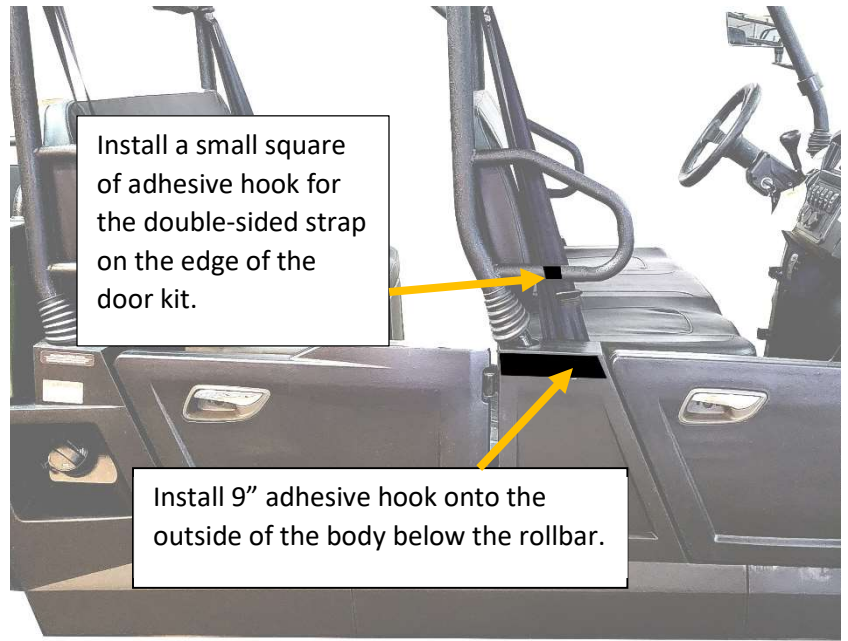

Install a small square of adhesive hook for the double-sided strap on the edge of the door kit.

Install 9" adhesive hook onto the outside of the body below the rollbar.

Fold tabs over the top roll bar and attach loop on the door to the adhesive hook.



Attach sewn in loop to sewn in hook on the outside of the back frame.

Magnets will attach to the metal bar sewn into the door.

Wrap these tabs around and attach to adhesive hook.

Attach sewn in loop to adhesive hook.

Attach sewn in loop to sewn in hook on the door cover.

Install the front door frame.

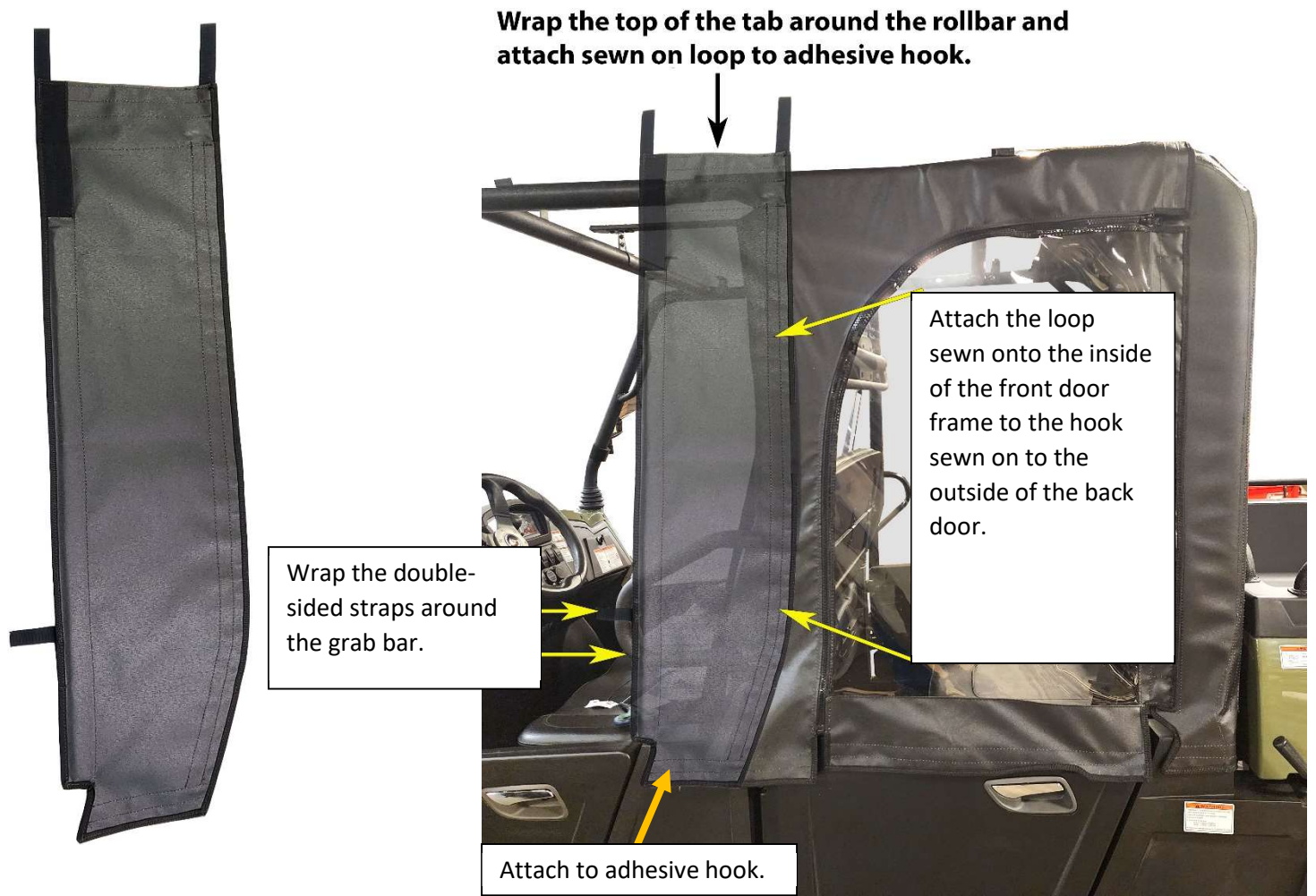

Install the front door.



Attach adhesive hook directly on to the body of the SXS. These strips are for the loop sewn on to the lower front portion of the door kit.

Fold these tabs over and attach to adhesive hook.

The double sided straps on the front of the door will wrap around the front roll bar, under the windshield.



Loop sewn on to the door kit will attach to the hook on the outside of the door cover.





Care Instructions

Heavy Duty Marine and Mil-Spec Military Fabric Cleaning

All 3 STAR UTV Enclosure Heavy Duty Marine and Military Camo fabrics are guaranteed against excessive loss of color or strength under normal exposure and use conditions. Periodic cleaning with a solution of 4 ounces of bleach and 2 ounces of soap (NOT DETERGENTS) in one gallon of water is recommended to minimize accumulations of dirt, bird droppings and other contaminants which can support surface mildew and stain fabric.

Soft Vinyl Window Cleaning

3 STAR UTV Enclosure Vinyl Windows will remain clear and provide great visibility under normal exposure conditions if properly cleaned. Periodic cleaning with a solution of 1 ounce of soap in one gallon of water is all that is needed to maintain good window cleanliness and visibility. Caution: DO NOT USE ANY DETERGENTS, WINDOW CLEANERS, SOLVENTS or CHEMICALS OF ANY KIND TO CLEAN VINYL WINDOWS AS THESE WILL CLOUD THE WINDOWS. ALSO, NEVER RUB WINDOWS WITH A DRY CLOTH OR RAG.

Storage Recommendations

Before removing the 3 STAR UTV Enclosure from your vehicle for storage, clean the Fabric and Vinyl Windows thoroughly as indicated above. Any dirt remaining on the Enclosure may scratch Vinyl Windows while in storage. Once the Enclosure has been cleaned it should be placed on a large flat surface. Lay the Enclosure out so that Vinyl Windows are in a flat position. Fold the doors over the rear panel first then fold the top and windshield on top of the doors keeping the Vinyl Windows flat. Caution: **FOLDING VINYL WINDOWS WILL CAUSE PERMANENT CREASE DAMAGE AND WILL VOID ALL WARRANTIES.** Once the Enclosure is folded keeping all Vinyl Windows flat, begin rolling the Enclosure into an 8" roll. Place the 8" roll into a box and store at normal room temperature. To ensure long life of your enclosure it is best not to store in extreme temperatures.

Hauling

The ONLY products manufactured by 3 STAR UTV that can be hauled while installed are the hard windshields, full cab enclosures, and door/rear window combos with top and windshield installed. **However, the full cab enclosures and door/rear window combos should be tied down before hauling.** Speed should not exceed 55 mph while hauling to prevent ripping and shredding of the material and zippers. NEVER HAUL INSTALLED SOFT TOPS, WINDSHIELD TOP COMBOS, AND SUMMER CABS. **REMOVE BEFORE HAULING.**