

# Flexigas

## Installation manual - UK

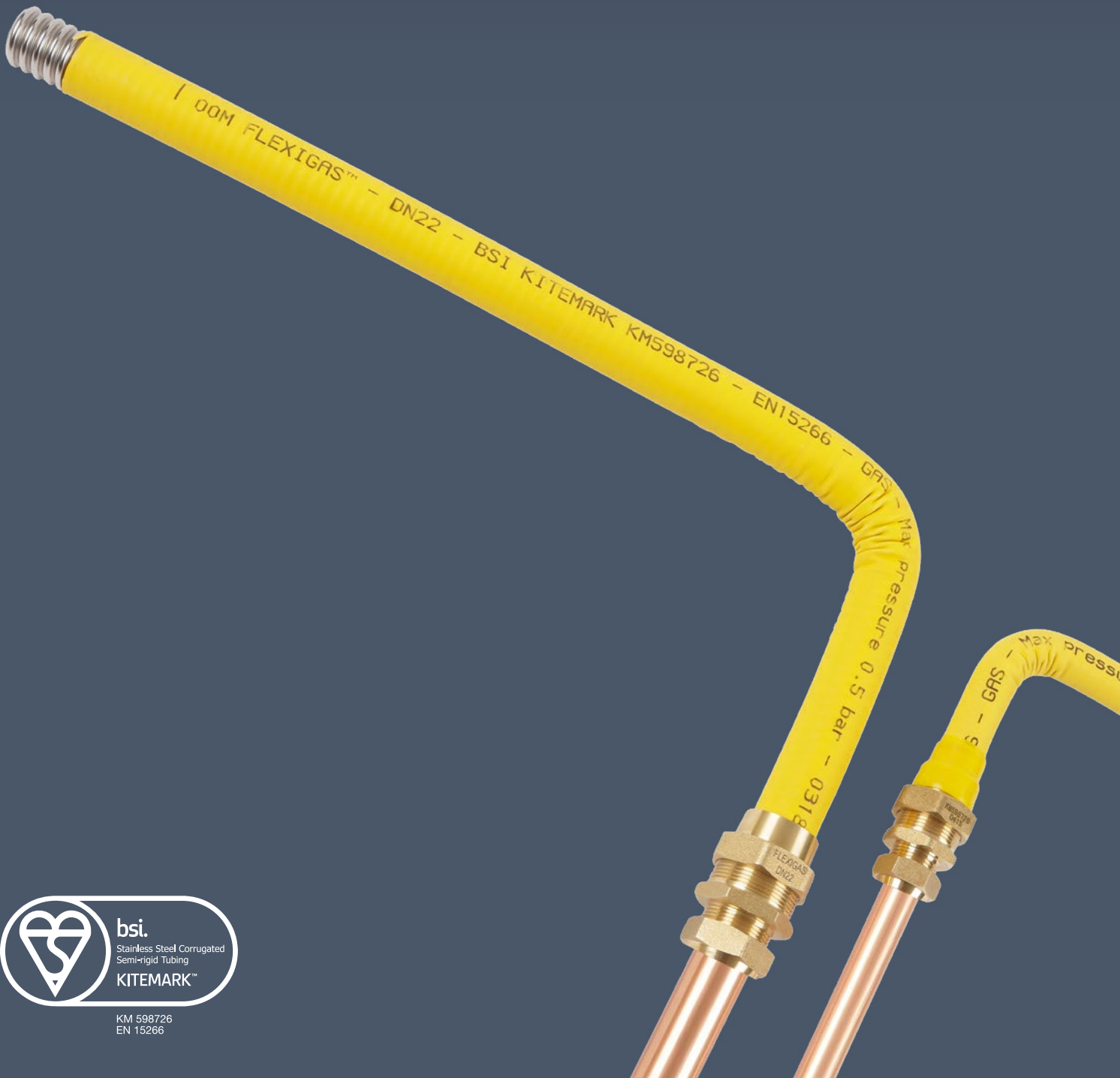

bsi.  
Stainless Steel Corrugated  
Semi-rigid Tubing  
KITEMARK™

KM 598726  
EN 15266

In the United Kingdom (including Northern Ireland and the Isle of Man) all work on gas installations (including but not limited to the servicing, installation and maintenance of the Flexigas system, or any attached gas appliance, fittings or conveyance system) must be carried out by a business or self employed persons approved by the Health and Safety Executive. At the time of publication of this manual the current registration body is the Gas Safe Register.

Persons operating as gas engineers must hold a valid certificate of competence for this work activity. This certificate must have been issued under the Nationally Accredited Certification Scheme (ACS) or a National/Scottish Vocation Qualification (NVQ/SVQ) that is allied to the ACS.

All gas work and installations, including the installation of the Flexigas system, must always be carried out in accordance with The Gas Safety (Installation and Use) Regulations 1998 (including additions and addendums), British Standards, Local Building Regulations and this Installation Manual. While FlexiPipe-Flexigas Ltd will make every endeavour to update this installation manual to follow any changes to the Regulations and British Standards, it may not always be possible to do so. The qualified gas engineer using the Flexigas system must always ensure they are aware of any changes to the Local/National Regulations that apply to the work they are carrying out. In the event of a discrepancy between any Regulations/British Standards and this Installation manual the former shall take precedence.

Only components provided or specified by FlexiPipe-Flexigas Ltd as comprising part of the approved Flexigas Corrugated Stainless Steel Tubing (CSST) system for gas installations may be used in the installation. The direct joining of the Flexigas system with other flexible piping systems has not been tested and is strictly forbidden. Joining of the Flexigas system to other piping systems (including other flexible CSST piping systems) is only permitted by use of an approved BSP thread connector as outlined in this manual.

While CSST gas systems such as Flexigas provide significant safety advantages over rigid gas delivery systems (including reduced likelihood of leakage due to faulty installation and damage caused by geological events such as earthquakes), due to its reduced wall dimensions CSST may be more likely than rigid systems to be damaged by sharp objects, such as a nail or a screw, or by other unique occurrences, such as a lightning strike. The proper grounding/earth bonding of the system will significantly reduce the risk from the latter and all installed Flexigas systems must be electrically bonded as per this manual (section 20) and British Standards (in particular BS 6891).

The Flexigas system should not be installed in any location where an excess degree of heat is likely to build up or be installed where it might be exposed to any naked flame.

Improper use or installation of the Flexigas CSST system may result in serious consequences, including but not limited to, fire, explosions, asphyxiation and gas poisoning. The Flexigas system must always be installed in strict accordance with British Standards, all applicable local or national regulations, and always by a licensed professional. All installed Flexigas systems must be inspected by an authorised local building official, as well as properly pressure tested, prior to being placed in service. FlexiPipe-Flexigas Ltd will have no responsibility over any misrepresentation of the information contained in this manual or for any improper installation or repair work carried out that does not strictly comply with current British Standards.

## Table of Contents

<b>1 - SCOPE</b> .....	<b>5</b>
<b>2 - COMPETENCE AND SYSTEM CONFORMITY</b> .....	<b>5</b>
<b>3 - STANDARDS &amp; REGULATIONS OF RELEVANCE TO THE INSTALLER</b> .....	<b>6</b>
<b>4 - THE FLEXIGAS SYSTEM AND ITS COMPONENTS</b> .....	<b>6</b>
<b>5 - HOW TO ASSEMBLE FLEXIGAS</b> .....	<b>14</b>
<b>6 - BEST PRACTICE</b> .....	<b>16</b>
<b>7 - SAFETY PRECAUTIONS BEFORE INSTALLATION WORK COMMENCES</b> .....	<b>16</b>
<b>8 - SPECIAL CARE WHEN LAYING OUT FLEXIGAS TUBING</b> .....	<b>17</b>
<b>9 - BEND RADII</b> .....	<b>17</b>
<b>10 - CONNECTION AND DISCONNECTION OF PIPES AND FITTINGS</b> .....	<b>17</b>
<b>11 - JOISTED FLOORS, ROOF SPACES &amp; COMPARTMENT FLOORS</b> .....	<b>18</b>
<b>12 - FLEXIGAS IN SOLID FLOORS</b> .....	<b>25</b>
<b>13 - FLEXIGAS IN WALLS</b> .....	<b>29</b>
<b>14 - SLEEVES</b> .....	<b>37</b>
<b>15 - FLEXIGAS IN DUCTS / VENTILATION</b> .....	<b>38</b>
<b>16 - FIRE PROTECTION/STOPPING</b> .....	<b>39</b>
<b>17 - PIPE SUPPORTS</b> .....	<b>42</b>
<b>18 - EXTERIOR PIPEWORK</b> .....	<b>42</b>
<b>19 - INTERRELATION WITH OTHER SERVICES</b> .....	<b>44</b>
<b>20 - MAIN EQUIPOTENTIAL BONDING</b> .....	<b>44</b>
<b>21 - VALVES (EMERGENCY CONTROL VALVES)</b> .....	<b>47</b>
<b>22 - PREVENTION OF CORROSION</b> .....	<b>48</b>
<b>23 - GAS TIGHTNESS TESTING AND PURGING</b> .....	<b>49</b>
<b>24 - CONNECTION OF FLEXIGAS TO OTHER SYSTEMS</b> .....	<b>49</b>
<b>25 - DAMAGE AND REPAIR</b> .....	<b>50</b>
<b>26 - WARRANTY</b> .....	<b>50</b>
<b>27 - GAS PIPEWORK INSIDE A PROTECTED AREA</b> .....	<b>51</b>
<b>28 - PIPE SIZING (INCLUDING EXAMPLE)</b> .....	<b>52</b>
<b>29 - SIZING TABLES</b> .....	<b>54</b>

## 1 - SCOPE

The key installation standard for the use and installation of Flexigas is BS 6891:2015 (for DN sizes 15-32) however for larger sizes (DN40, 50) and for working pressures above those covered by BS 6891, IGEM/UP/2 should be used. Any installer using Flexigas must be familiar with the updated version of these standards. This installation manual highlights key points of relevance from these standards however it not intended to cover every aspect of BS 6891 or IGEM/UP/2 as it relates to the use and installation of gas pipework including Flexigas. This installation manual should never be used as a replacement for BS 6891, IGEM/UP/2 or The Gas Safety (Installation and Use) Regulations 1998.

The Flexigas stainless steel corrugated tubing (CSST) system is approved for installations of natural gas and LPG in domestic, commercial and industrial applications.

This approval is made by British Standards Institute in accordance with EN15266:2007 Stainless steel pliable corrugated tubing kits in building for gas with an operating pressure up to 0.5 bar.

The BS Kitemark number for the Flexigas system is KM 598726.

Flexigas is one of a small number of UK CSST manufacturers that previously held a BSI Kitemark to BS 7838 before this standard was replaced by EN 15266. Flexigas continues to manufacture and test its products to both standards.



EN 15266  
KM 598726

## 2 - COMPETENCE AND SYSTEM CONFORMITY

Persons conducting gas installations like installing or repairing the Flexigas system must hold a valid certificate of competence for this work activity. This certificate must have been issued under the Nationally Accredited Certification Scheme (ACS) or a National/Scottish Vocation Qualification (NVQ/SVQ) that is allied to the ACS.

Only components provided or specified by Flexigas as comprising part of the approved Flexigas Corrugated Stainless Steel Tubing (CSST) system for gas Installations may be used in the installation. The direct joining of the Flexigas system with other flexible piping systems has not been tested and is strictly forbidden. Joining of the Flexigas system to other piping systems (including other flexible CSST piping systems) is only permitted by use of an approved BSP thread connectors as outlined in this manual.

### 3 - STANDARDS & REGULATIONS OF RELEVANCE TO THE INSTALLER

The below is a non-exhaustive list and the competent installer using the Flexigas system should consult any relevant standard for the work they are carrying out.

BS 6891:2005 – Installation of low pressure gas tubing of up to 25mm (R1 1/4) in domestic gas premises (2nd family gasses).

BS 7838: Specification for corrugated stainless steel semi-rigid pipe and associated fittings for low-pressure gas pipework of up to DN 50

BS/EN 15266:2007 Stainless steel pliable corrugated tubing kits in building for gas with an operating pressure up to 0.5 bar.

BS 5482 – Code of practice for domestic butane and propane gas-burning installations Part 1: Installations at permanent dwellings, residential park homes and commercial premises, with installation tube sizes not exceeding DN 25 for steel and DN 28 for corrugated stainless steel copper. IGEM/UP/2 Edition 2 – The Institution of Gas Engineers and Managers Communication – Installation pipework on industrial and commercial premises.

BS 7671:2008 – Requirements for electrical installations. IEE Wiring Regulations. Seventeenth edition.

BS/EN 1775:2007 – Gas supply. Gas tubing for buildings. Maximum operating pressure less than or equal to 5 bar. Functional recommendations.

BS 951:2009 - Electrical earthing. Clamps for earthing and bonding. Specification.

IGEM/UP/1 - Latest Edition - Strength testing/tightness testing/direct purging of industrial and commercial gas installations.

IGEM/UP/2 - Latest Edition - Installation pipework on Industrial and commercial premises.

IGEM/UP/5 - Latest Edition - Gas in multi occupancy buildings.

IGEM/UP/7 - Gas installations in timber framed and light steel framed building.

IGEM/UP/11 - Gas installations for educational establishments.

### 4 - THE FLEXIGAS SYSTEM AND ITS COMPONENTS

Flexigas Tubing is made from 316L / 321 stainless steel with a flame retardant Polyethylene cover.

Tubing Size	DN 15	DN 22	DN 28	DN 32	DN 40	DN 50
Outer Diameter (without cover)	18.1mm	25.6mm	32mm	38mm	50mm	60mm
Internal Diameter	14.1mm	21.4mm	27mm	33mm	41mm	50mm
Tubing Wall Thickness	0.25mm	0.25mm	0.25mm	0.25mm	0.30mm	0.30mm
Polyethylene Cover Thickness	0.80mm	0.80mm	0.80mm	0.80mm	0.80mm	0.80mm

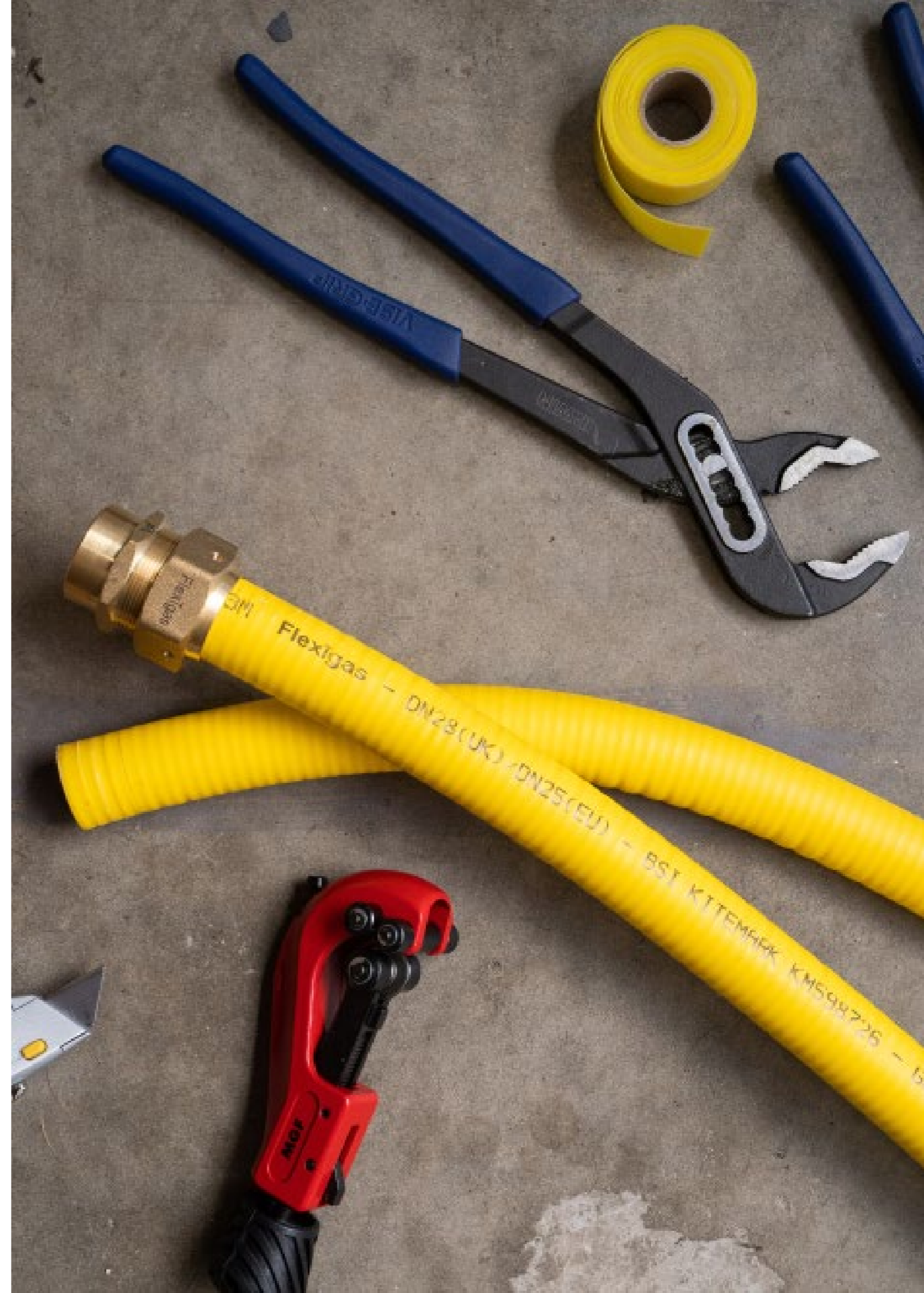



**TUBING**

DN15-15m 15MM Flexible Gas Pipe 15m  
 DN15-25m 15MM Flexible Gas Pipe 25m  
 DN15-50m 15MM Flexible Gas Pipe 50m  
 DN15-75m 15MM Flexible Gas Pipe 75m

DN22-15m 22MM Flexible Gas Pipe 15m  
 DN22-25m 22MM Flexible Gas Pipe 25m  
 DN22-50m 22MM Flexible Gas Pipe 50m  
 DN22-75m 22MM Flexible Gas Pipe 75m  
 DN22-400m 22MM Flexible Gas Pipe 400m



DN28-15m 28MM Flexible Gas Pipe 15m  
 DN28-25m 28MM Flexible Gas Pipe 25m  
 DN28-50m 28MM Flexible Gas Pipe 50m  
 DN28-75m 28MM Flexible Gas Pipe 75m  
 DN28-90m 28MM Flexible Gas Pipe 90m  
 DN28-400m 28MM Flexible Gas Pipe 400m



DN32-15m 32MM Flexible Gas Pipe 15m  
 DN32-25m 32MM Flexible Gas Pipe 25m  
 DN32-50m 32MM Flexible Gas Pipe 50m  
 DN32-75m 32MM Flexible Gas Pipe 75m  
 DN32-90m 32MM Flexible Gas Pipe 90m  
 DN32-350m 32MM Flexible Gas Pipe 350m

DN40-50m 40MM Flexible Gas Pipe 50m  
 DN40-75m 40MM Flexible Gas Pipe 75m  
 DN40-200m 40MM Flexible Gas Pipe 300m

DN50-50m 50MM Flexible Gas Pipe 50m  
 DN50-200m 50MM Flexible Gas Pipe 300m

**ACCESSORIES**



SPL-01 Spool Stand 50m/75m  
 SPL-02 Spool roller system for 300-400m coils  
 TCR-01 Tubing Cutter  
 ST-01 Silicone Tape 2m  
 ST-02 Silicone Tape 11m  
 EE01 Sleeving for Flexigas Tubing (DN22, 28)  
 EE02 Sleeving for Flexigas Tubing (DN32, 40)

**FITTINGS**

**MALE UNION**



SM 15-12 15 Flexigas x 1/2" Male BSP  
 SM 15-34 15 Flexigas x 3/4" Male BSP  
 SM 22-34 22 Flexigas x 3/4" Male BSP  
 SM 22-10 22 Flexigas x 1" Male BSP  
 SM 28-10 28 Flexigas x 1" Male BSP  
 SM 28-114 28 Flexigas x 1.1/4" Male BSP  
 SM 32-114 32 Flexigas x 1.1/4" Male BSP  
 SM 40-112 40 Flexigas x 1.1/2" Male BSP  
 SM 50-10 50 Flexigas x 2" Male BSP

**FEMALE UNION**



SF 15-12 15 Flexigas x 1/2" Female BSP  
 SF 15-34 15 Flexigas x 3/4" Female BSP  
 SF 15-10 15 Flexigas x 1" Female BSP  
 SF 22-12 22 Flexigas x 1/2" Female BSP  
 SF 22-34 22 Flexigas x 3/4" Female BSP  
 SF 22-10 22 Flexigas x 1" Female BSP  
 SF 28-10 28 Flexigas x 1" Female BSP  
 SF 28-114 28 Flexigas x 1.1/4" Female BSP  
 SF 32-114 32 Flexigas x 1.1/4" Female BSP  
 SF 32-112 32 Flexigas x 1.1/2" Female BSP  
 SF 40-20 40 Flexigas x 2" Female BSP

**FLEXIGAS UNION**



SU 15 15 Flexigas x 15 Flexigas  
 SU 22 22 Flexigas x 22 Flexigas  
 SU 28 28 Flexigas x 28 Flexigas  
 SU 32 32 Flexigas x 32 Flexigas  
 SU 40 40 Flexigas x 40 Flexigas  
 SU 50 50 Flexigas x 50 Flexigas

4 - THE FLEXIGAS SYSTEM AND ITS COMPONENTS (CONTINUED)

FLEXIGAS REDUCING UNIONS



SR 22-15	22 Flexigas x 15 Flexigas
SR 28-15	28 Flexigas x 15 Flexigas
SR 28-22	28 Flexigas x 22 Flexigas
SR 32-22	32 Flexigas x 22 Flexigas
SR 32-28	32 Flexigas x 28 Flexigas
SR 40-28	40 Flexigas x 28 Flexigas
SR 40-32	40 Flexigas x 32 Flexigas

FLEXIGAS TO COPPER - STRAIGHT UNION



CC 15-15	15 Flexigas x Copper 15mm
CC 15-22	15 Flexigas x Copper 22mm
CC 15-28	15 Flexigas x Copper 28mm
CC 22-15	22 Flexigas x Copper 15mm
CC 22-22	22 Flexigas x Copper 22mm
CC 22-28	22 Flexigas x Copper 28mm
CC 28-22	28 Flexigas x Copper 22mm
CC 28-28	28 Flexigas x Copper 28mm
CC 28-35	28 Flexigas x Copper 35mm
CC 32-28	32 Flexigas x Copper 28mm
CC 32-35	32 Flexigas x Copper 35mm
CC 32-42	32 Flexigas x Copper 42mm
CC 40-35	40 Flexigas x Copper 35mm
CC 40-42	40 Flexigas x Copper 42mm
CC 40-54	40 Flexigas x Copper 54mm

FLEXIGAS ELBOW



EE 15	15 Flexigas x 15 Flexigas
EE 22	22 Flexigas x 22 Flexigas
EE 28	28 Flexigas x 28 Flexigas
EE 32	32 Flexigas x 32 Flexigas
EE 40	40 Flexigas x 40 Flexigas

MALE ELBOW



EM 15-12	15 Flexigas x 1/2" Male BSP
EM 22-34	22 Flexigas x 3/4" Male BSP
EM 22-10	22 Flexigas x 1" Male BSP

4 - THE FLEXIGAS SYSTEM AND ITS COMPONENTS (CONTINUED)

FLEXIGAS TO COPPER - ELBOW



ECC 15-15	15 Flexigas x Copper 15mm
ECC 15-22	15 Flexigas x Copper 22mm
ECC 15-28	15 Flexigas x Copper 28mm
ECC 22-15	22 Flexigas x Copper 15mm
ECC 22-22	22 Flexigas x Copper 22mm
ECC 22-28	22 Flexigas x Copper 28mm
ECC 28-22	28 Flexigas x Copper 22mm
ECC 28-28	28 Flexigas x Copper 28mm
ECC 28-35	28 Flexigas x Copper 35mm
ECC 32-28	32 Flexigas x Copper 28mm
ECC 32-35	32 Flexigas x Copper 35mm
ECC 32-42	32 Flexigas x Copper 42mm
ECC 40-35	40 Flexigas x Copper 35mm
ECC 40-42	40 Flexigas x Copper 42mm
ECC 40-54	40 Flexigas x Copper 54mm

FEMALE ELBOW



EF 15-12	15 Flexigas x 1/2" Female BSP
EF 15-34	15 Flexigas x 3/4" Female BSP
EF 22-34	22 Flexigas x 3/4" Female BSP
EF 22-10	22 Flexigas x 1" Female BSP
EF 28-114	28 Flexigas x 1.1/4" Female BSP
EF 32-112	32 Flexigas x 1.1/2" Female BSP
EF 40-20	40 Flexigas x 2" Female BSP

WINGED FEMALE ELBOW



EFW 15-12	15 Flexigas x 1/2" Female BSP
-----------	-------------------------------

EQUAL TEES



TT 15	15 Flexigas x 15 Flexigas x 15 Flexigas
TT 22	22 Flexigas x 22 Flexigas x 22 Flexigas
TT 28	28 Flexigas x 28 Flexigas x 28 Flexigas
TT 32	32 Flexigas x 32 Flexigas x 32 Flexigas
TT 40	40 Flexigas x 40 Flexigas x 40 Flexigas

#### 4 - THE FLEXIGAS SYSTEM AND ITS COMPONENTS (CONTINUED)



##### FEMALE ADAPTER TEE

TF 15-12	15 Flexigas (ends) x 1/2" Female BSP (middle branch)
TF 22-34	22 Flexigas (ends) x 3/4" Female BSP (middle branch)

##### REDUCING TEE



TR 22-15-15	22 Flexigas x 15 Flexigas x 15 Flexigas (middle branch)
TR 22-22-15	22 Flexigas x 22 Flexigas x 15 Flexigas (middle branch)
TR 22-15-22	22 Flexigas x 15 Flexigas x 22 Flexigas (middle branch)
TR 28-28-22	28 Flexigas x 28 Flexigas x 22 Flexigas (middle branch)
TR 28-28-15	28 Flexigas x 28 Flexigas x 15 Flexigas (middle branch)
TR 32-32-28	32 Flexigas x 32 Flexigas x 28 Flexigas (middle branch)
TR 32-32-22	32 Flexigas x 32 Flexigas x 22 Flexigas (middle branch)
TR 40-40-32	40 Flexigas x 40 Flexigas x 32 Flexigas (middle branch)
TR 40-40-28	40 Flexigas x 40 Flexigas x 28 Flexigas (middle branch)

##### FLEXIGAS TO COPPER - TEES



C15-15-15	Copper 15mm x 15 Flexigas x 15 Flexigas (middle)
C22-15-15	Copper 22mm x 15 Flexigas x 15 Flexigas (middle)
C22-22-22	Copper 22mm x 22 Flexigas x 22 Flexigas (middle)
C28-22-22	Copper 28mm x 22 Flexigas x 22 Flexigas (middle)
C28-28-28	Copper 28mm x 28 Flexigas x 28 Flexigas (middle)
C35-28-28	Copper 35mm x 28 Flexigas x 28 Flexigas (middle)
C35-32-32	Copper 35mm x 32 Flexigas x 32 Flexigas (middle)
C42-32-32	Copper 42mm x 32 Flexigas x 32 Flexigas (middle)
C42-40-40	Copper 42mm x 40 Flexigas x 40 Flexigas (middle)
C54-40-40	Copper 54mm x 40 Flexigas x 40 Flexigas (middle)



C15-C15-15	Copper 15mm x Copper 15mm x 15 Flexigas (middle)
C22-C15-15	Copper 22mm x Copper 15mm x 15 Flexigas (middle)
C22-C22-22	Copper 22mm x Copper 22mm x 22 Flexigas (middle)
C28-C22-22	Copper 28mm x Copper 22mm x 22 Flexigas (middle)
C28-C28-28	Copper 28mm x Copper 28mm x 22 Flexigas (middle)
C35-C28-28	Copper 35mm x Copper 28mm x 28 Flexigas (middle)
C35-C35-32	Copper 35mm x Copper 35mm x 32 Flexigas (middle)
C42-C35-32	Copper 42mm x Copper 35mm x 32 Flexigas (middle)
C42-C42-40	Copper 42mm x Copper 42mm x 40 Flexigas (middle)
C54-C42-40	Copper 54mm x Copper 42mm x 40 Flexigas (middle)
C54-C54-40	Copper 54mm x Copper 54mm x 40 Flexigas (middle)

#### 4 - THE FLEXIGAS SYSTEM AND ITS COMPONENTS (CONTINUED)



C15-15-C15	Copper 15mm x 15 Flexigas x Copper 15mm (middle)
C22-15-C15	Copper 22mm x 15 Flexigas x Copper 15mm (middle)
C22-22-C22	Copper 22mm x 22 Flexigas x Copper 22mm (middle)
C28-22-C22	Copper 28mm x 22 Flexigas x Copper 28mm (middle)
C28-28-C28	Copper 28mm x 28 Flexigas x Copper 28mm (middle)
C35-28-C28	Copper 35mm x 28 Flexigas x Copper 28mm (middle)
C35-32-C35	Copper 35mm x 32 Flexigas x Copper 35mm (middle)
C42-32-C35	Copper 42mm x 32 Flexigas x Copper 42mm (middle)
C42-40-C42	Copper 42mm x 40 Flexigas x Copper 42mm (middle)
C54-40-C42	Copper 54mm x 40 Flexigas x Copper 42mm (middle)
C54-40-C54	Copper 54mm x 40 Flexigas x Copper 54mm (middle)

##### FLOWFLEX ADAPTERS



A-15	Flexigas 15 to Flowflex 22mm
A-22	Flexigas 22 to Flowflex 28mm
A-28	Flexigas 28 to Flowflex 35mm
A-32	Flexigas 32 to Flowflex 42mm
A-40	Flexigas 40 to Flowflex 54mm

\*Adapter fittings can only be used by stockists and installers that have completed a Flexigas training course on how to assemble Adapter fittings.

\*\*Adapter fittings can only be combined with fittings included on the Flowflex/Flexigas compatibility spec sheet available from Flexigas

##### EARTHING TERMINAL



EB-01	Integrated earthing terminal
-------	------------------------------

## 5A - HOW TO ASSEMBLE FLEXIGAS



**Step 1 - Cut**  
Cut the Flexigas tubing using a wheel metal pipe cutter. Ensure the cut is centered in the valley between corrugations and the cutter is only slightly tightened on each full revolution around the tube. Make sure the cut is clean and circular with no sharp edges.



**Step 2 - Remove**  
With a utility knife, safely remove the flame retardant yellow cover so that the last four corrugations are exposed.

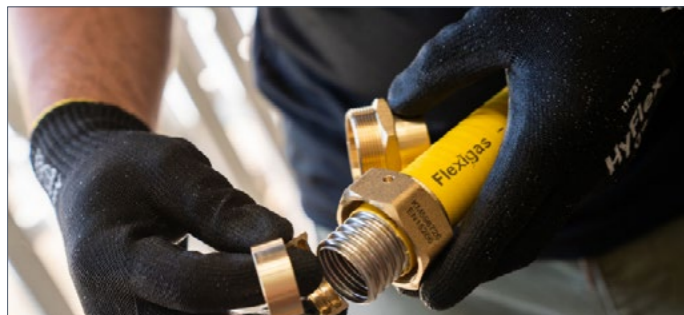

**Step 3 - Slide**  
Slide the nut over the tubing and then place the two semi-circular collets around the tubing so that the ridges on the collets occupy the last three valleys of tubing.

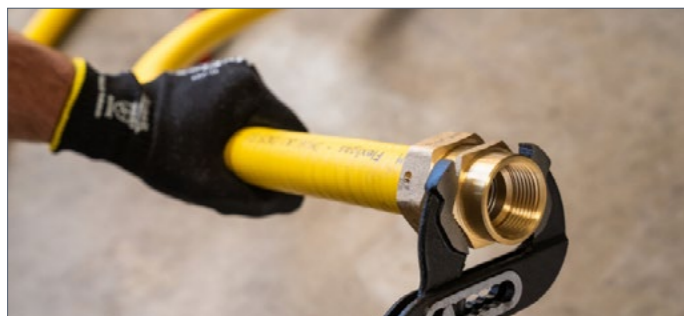

**Step 4 - Tighten**  
Tighten the nut and fitting using two suitably sized wrenches. The seal is formed when the last corrugation deforms around the seat inside the fitting. Use sufficient torque.



**Step 5 - Wrap**  
After conducting a gas tightness test, wrap the small gap between the 'tail' on the nut and the tube using yellow silicone tape.

## 5B- HOW TO EARTH BOND FLEXIGAS

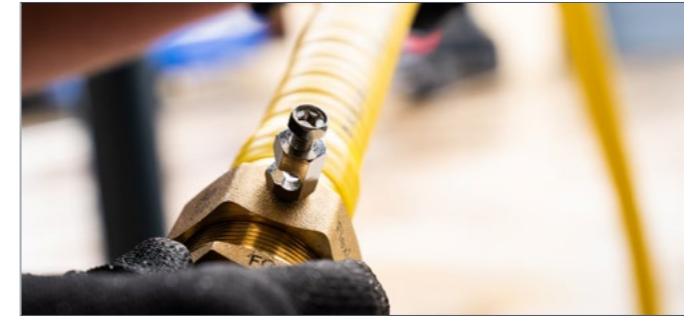

**Step 6 - Attach**  
Attach a bonding nut to the fitting body. Attach the warning label between the earthing terminal and Flexigas nut.



**Step 7 - Bond**  
Strip earthing cable to reveal 1-2cm of copper wire. Screw down onto copper wire.  
\*Consult Section 20 for more information.

The Flexigas integrated bonding terminal is included in our Kitemark from BSI, and has been certified as meeting the relevant tests from BS 951:2009





## 6 - BEST PRACTICE

The following is considered general best practice when installing Flexigas:

- Ensure all Flexigas components are physically stored, located or once installed located where it is not liable to mechanical damage.
- Ensure the bore of the Flexigas tubing is not restricted by kinks, burrs, foreign material or in any other way.
- Ensure that you have adequate length of Flexigas tubing before you start work and where possible make continuous runs of tubing.
- Take care when opening the packaging as the pipe is stored in a coil and will release upon opening.
- While unrolling the tubing ensure that no kinks or twisting in the tube occurs.
- Ensure that neither the tube nor fittings are stored in extreme temperatures, however where they have been exposed to such temperatures do not make any connections of the components before they have returned to room temperature.

Anytime after the tubing or fittings have been removed from their packaging, and especially during installation on site, care should be taken so that dirt, water or other building materials does not enter the tubing.

Any foreign material entering the system can severely restrict normal flow and even restrict flow altogether.

## 7 - SAFETY PRECAUTIONS BEFORE INSTALLATION WORK COMMENCES

Where work is taking place on pipe already connected to a gas meter either

1. The meter should be disconnected with both open ends of the tubing sealed with dust caps fitted to the meter, or
2. All open ends of the tubing will be terminated with a self sealing appliance connector that conforms to BS 669: Part 1 or BS 669: Part 2.

After the completion of work all open ends of the tubing shall be plugged, capped or terminated with a self sealing appliance connector complying with BS 669: Part 1 or BS 669: Part 2. Installers also need to consider the risk of persons restoring the gas supply at the primary meter should they leave the general location where the work is in progress.

## 8 - SPECIAL CARE WHEN LAYING OUT FLEXIGAS TUBING

Flexigas is easily introduced and passed along small spaces where it might be hard to see the location of existing services. As such special care should be taken not to damage any existing services, in particular electrical services, such as cables, junction boxes, etc. Installers should also reference bonding requirements in Section 20.

The installer should also take note and mark the location of Flexigas tubing behind wall spaces, under flooring, or any other location that might put it at risk of being damaged by a nail, screw or other sharp object.

## 9 - BEND RADIUS

Flexigas can be easily passed around objects and bent by hand, including making tight bends if necessary. However, such tight bends should be avoided where possible as multiple tight bends can restrict gas flow and increase pressure drop.

It is preferable to make larger smoother bends with a higher radius to reduce pressure loss. It is also recommended to avoid repeated bending during installation.

Size	Min Bend Radius	Suggested Bend Radius
DN 15	20 mm	75 mm
DN 22	25 mm	75 mm
DN 28	75 mm	125 mm
DN 50	75 mm	125 mm
DN 40	75 mm	125 mm
DN 50	90 mm	125 mm

## 10 - CONNECTION AND DISCONNECTION OF PIPES AND FITTINGS

Where any installation pipe is no longer required, the pipe(s) shall be disconnected as close to the point of supply as practicable. All pipe ends shall be sealed with an appropriate fitting, e.g. a plug or cap.

During any work that necessitates connection or disconnection of any metal installation pipework, a temporary continuity bond shall be fixed where production of a spark or shock could cause a hazard, whether or not permanent equipotential bonding has been established (see Section 20).

Where practicable, any redundant pipework should be removed.

The recommended disconnection procedure is as follows:

1. Isolate the electrical connection of associated gas appliances from the electricity mains supply.
2. Clip or clamp a temporary continuity bond to each side of the union, fittings or complete section that is to be removed or connected ensuring that good metallic contact is made (see Figure 3).
3. Leave the bond in position until after the work is completed and metallic continuity re-established.

A recommended temporary continuity bond comprise at least 1.2 m of single-core insulated flexible cable or equivalent of at least 250 V rating. The cable should have a cross-sectional area of not less than 10 mm<sup>2</sup> and multi-strand flexible construction generally in accordance with BS 6004, BS 6007 or BS 6231 with a robust clip or clamp firmly attached at each end.

Where the meter is removed BS 6400 should be consulted.

Flexigas can be directly connected to the gas meter, providing the gas meter is securely attached to the floor or wall. If the gas meter is not adequately restrained, rigid pipework such as copper should be used for the first 600mm.

**Additionally, running Flexigas all the way to the gas meter is even easier using the Flexigas integrated CSST earthing terminal (see Section 20), as the earthing conductor can be easily attached at the gas meter.**

## 11 - JOISTED FLOORS, ROOF SPACES & COMPARTMENT FLOORS

Flexigas laid in joisted floors and roof spaces shall run either in the direction of the joists or at 90° to the joist direction. Diagonal runs are not to be installed.

Notches shall be in accordance with the following Figures 1A -1D. Joists less than 100 mm or greater than 250mm shall not be notched.

Where Flexigas is installed between solid timber joists in floors, intermediate floors or roof spaces, it should be correctly supported in accordance with section 17:

- Where pipes are installed between timber engineered joists, the Flexigas shall be installed through the web of joists in accordance with Figure 1C and the joist manufacturer's guidance.
- Where pipes are installed between metal web joists the pipes shall pass between the metal webs with pipe supports fixed to the top or bottom of the timber flanges and not in contact with the metal structure of the joists.
- The flanges of timber engineered joists and metal web joists shall not be notched.
- Where pipes are laid across solid timber joists fitted with flooring they shall be located in purpose made notches or circular holes.
- Where pipework is installed within roof spaces, roof rafters, purlins, trussed rafters, bracing, etc., shall only be notched, drilled or cut away with the approval of a structural engineer.
- Prior to running pipework below suspended floors a visual inspection should be carried out to note the position of any electrical cables, junction boxes and ancillary equipment, in order that accidental damage or injury does not occur when inserting pipework.
- Where pipework is installed in a void under a floor, or where pipework is installed within intermediate joisted floors, unless there is sufficient adventitious ventilation available, ventilation shall be provided in accordance with Section 15. For LPG and LPG/air mixtures this ventilation shall be at the lowest point.
- Care should be taken when re-fixing flooring to prevent damage to the pipes by nails or screws. Where possible, the flooring should be appropriately marked to warn others. Where possible the design should remove the need for notching solid timber joists.

For best practice, it is recommended to keep fixings to a minimum (without going over the max distance between fixings outlined here or in BS 6891) to increase the likelihood of the tubing deflecting away from any protruding object such a nail or screw.

Pipework shall not be installed within any fire compartment floor that separates one dwelling from another part of the building, except as shown in Figure 1C & 1D.

Roof spaces utilizing vapour permeable underlay without specific ventilation, such as soffit board vents, shall be treated as unventilated voids for the purpose of gas pipework and appliance installations. Where it is necessary to install pipework in such locations, additional ventilation shall be applied having at least two ventilators per space, each with a free area of at least 50 cm<sup>2</sup>. For LPG and LPG/Air mixtures, this shall be at low level; for natural gas this shall be at high level.

Pipework shall not be laid below or within roof space insulation material.

It is recommended to use a drill hole size 20mm larger than the Flexigas DN size.

Figure 1A - Limits for notching and drilling of solid timber floor joists

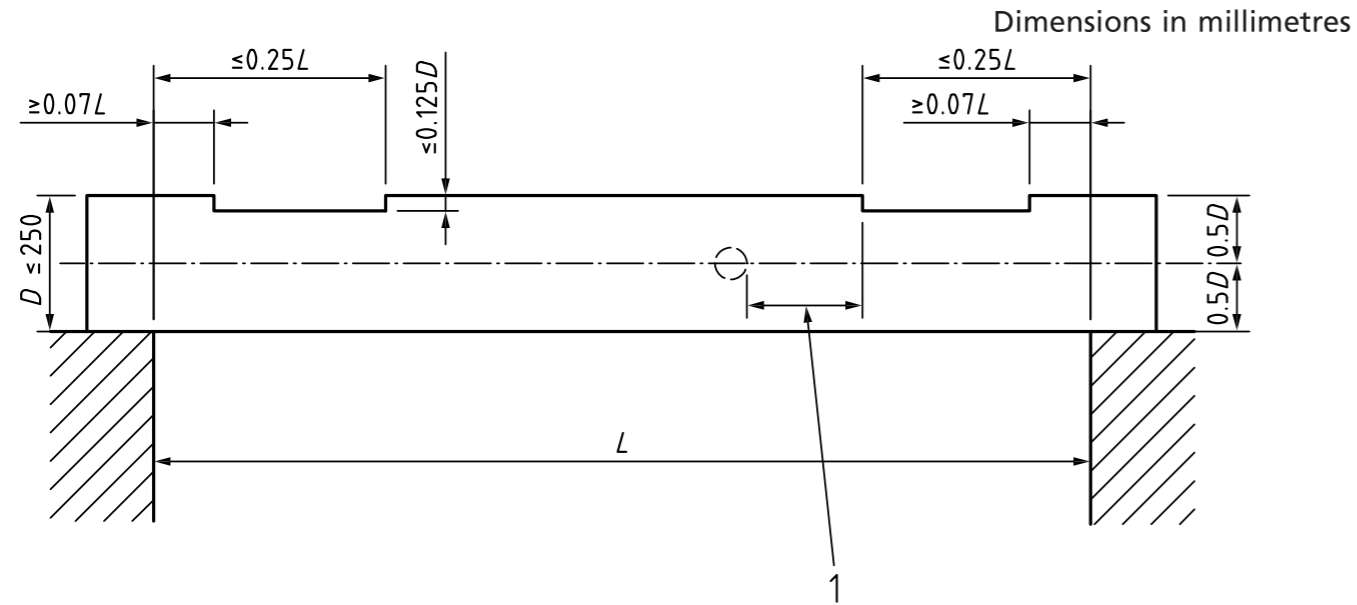

a) Limits for notching top of joist where drilling and notching occur

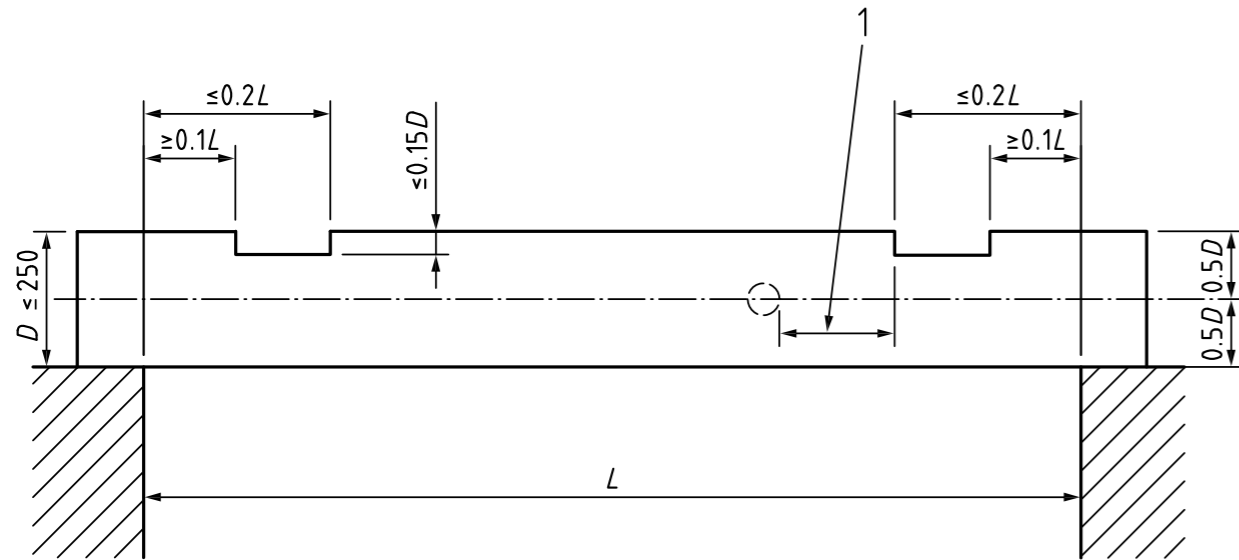

b) Alternative limits for notching top of joist where drilling and notching occur

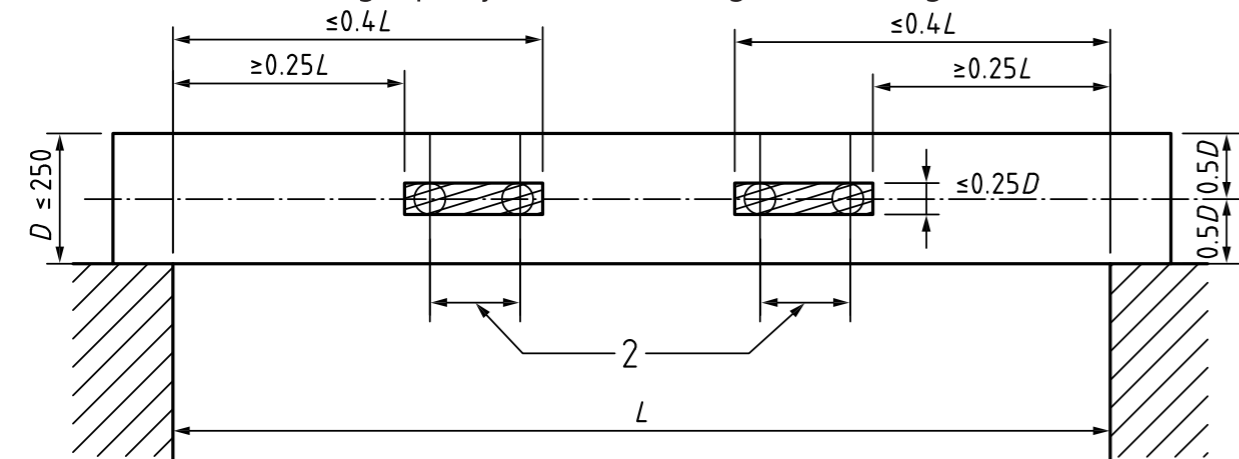

c) Limits for drilling of joists where drilling and notching occur

- Key**
- 1 Min. 100 mm between notch and hole
  - 2 Holes not closer than 3 × diameter

**NOTE 1** The notching can occur at both ends, either on top or bottom, without a design check.

Figure 1A - Limits for notching and drilling of solid timber floor joists

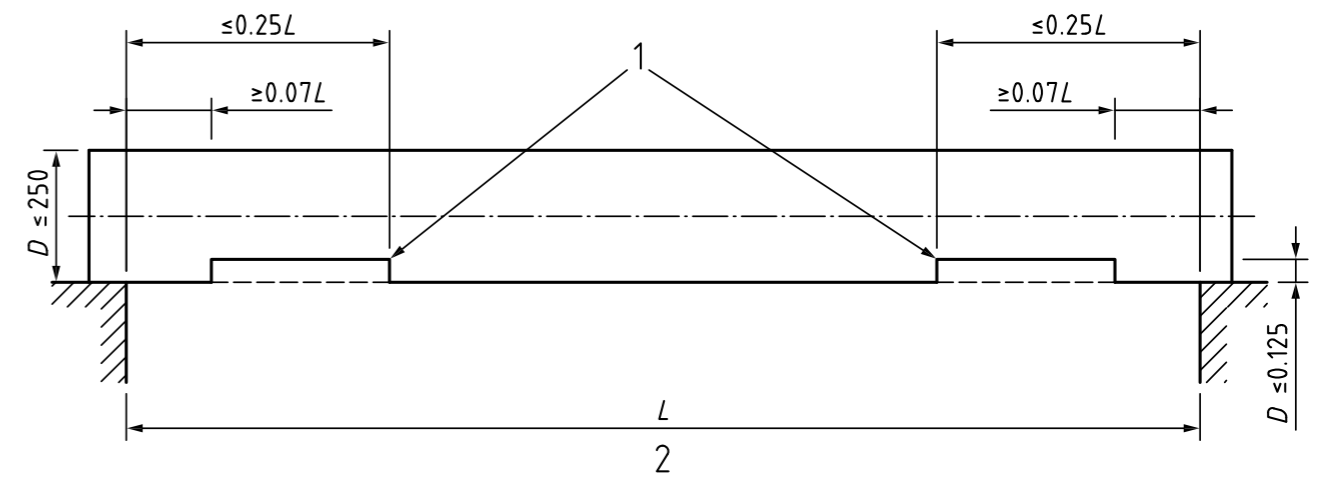

**Key**

- 1 Positions within which notching can occur on the bottom without a design check. Minimum 100 mm between the notch and any holes [see Figure 13a)].
- 2 Clear span simply supported joist (not a trimmer, trimming joist or beam)

**NOTE 2** The notching can occur at both ends, either on top or bottom, without a design check.

d) Limits for notching bottom of joist where drilling and notching occur

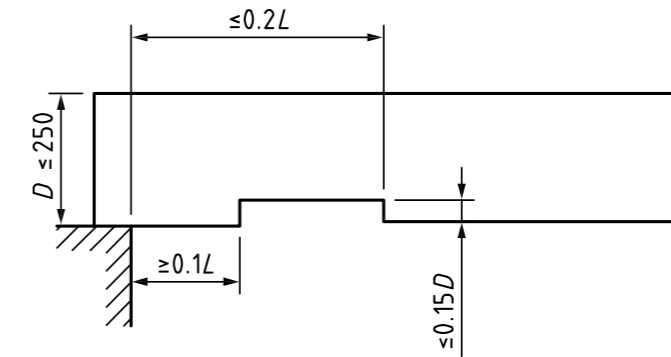

**NOTE 3** The notching can occur at both ends on the bottom without a design check.

e) Alternative limits for notching: bottom of joist where drilling and notching occur

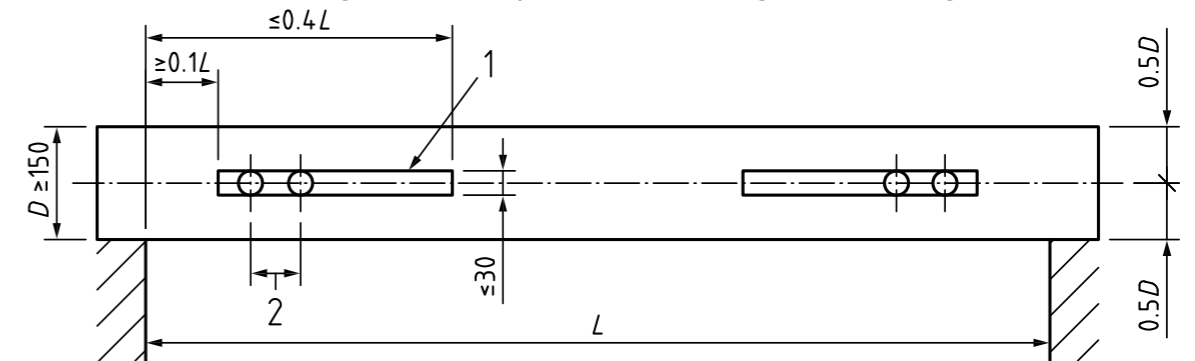

f) Alternative drilling zone where no notching occurs

**Key**

- 1 Drilling zone where no notching occurs
- 2 Holes not closer than 3 × diameter of largest hole and a maximum of 8 × 30 mm holes can be accommodated within each drilling zone. No notching is permitted.

Figure 1B - Notching and drilling of metal web joists and timber engineered joists

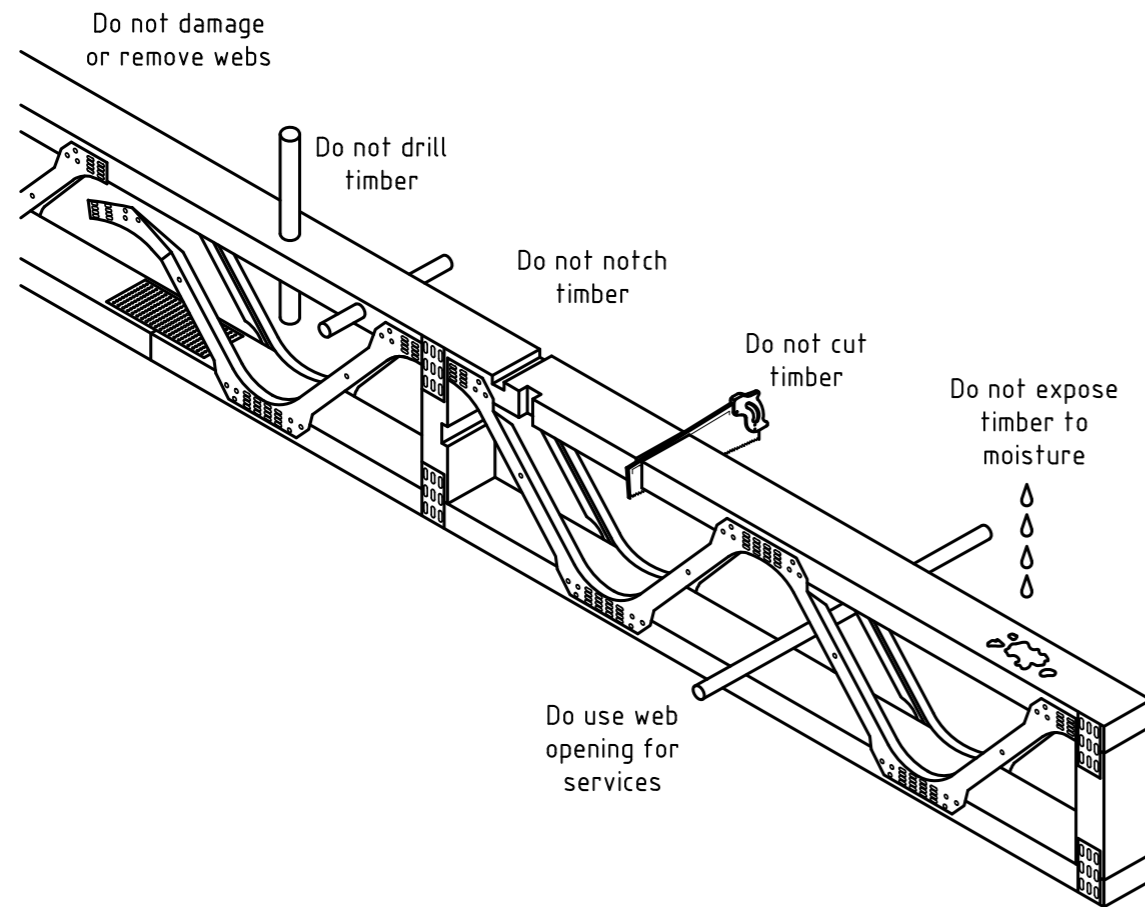

a) Restrictions on notching and drilling metal web joists

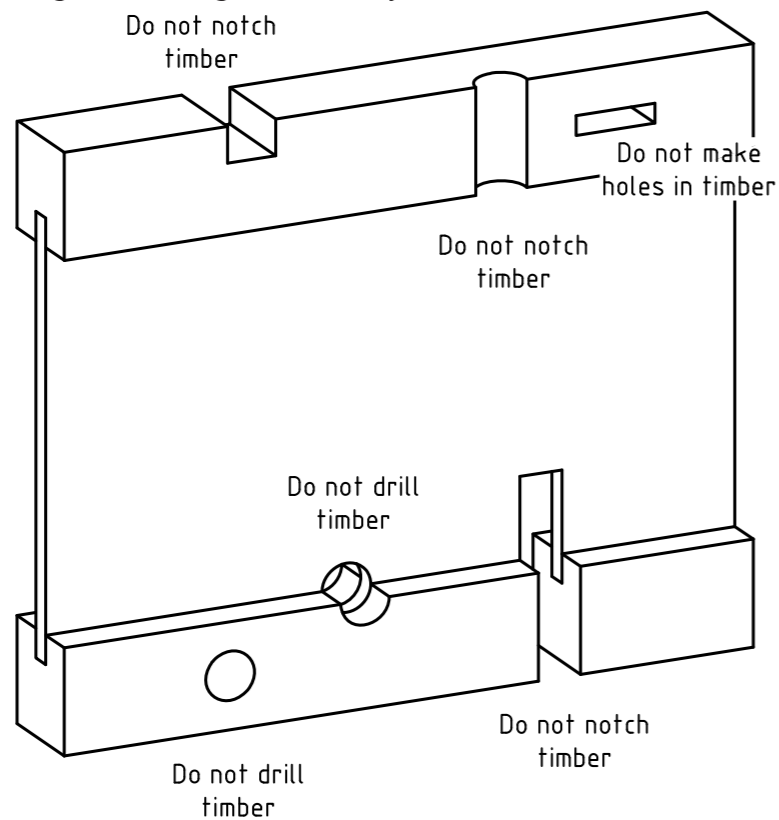

b) Restrictions on notching and drilling timber-engineered joists

Figure 1C - Flexigas in concrete compartment floors

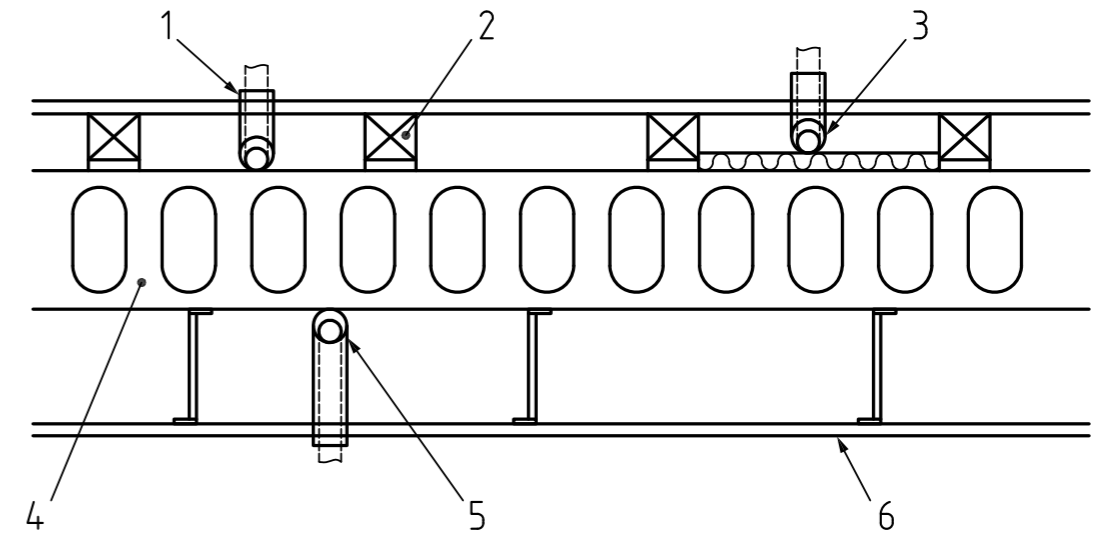

a) Typical concrete compartment floor with suspended ceiling and topping of timber decking on battens

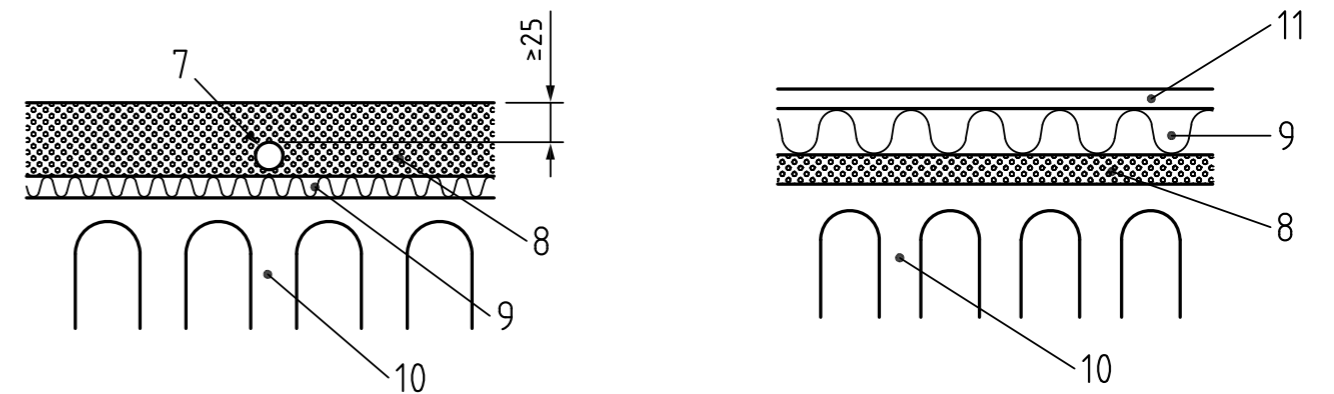

b) Alternative screed topping

c) Alternative timber floating floor topping (No pipework to be installed in this type of floor topping)

**Key**

- 1 Pipework within vented ducting extended above floor level and sealed to floor deck with flexible sealant
- 2 Floor decking on battens on resilient bearers/pads
- 3 Ducted pipework can be above or below any resilient quilt laid between floor battens with no fixings used to secure the ducting penetrating or damaging the quilt
- 4 Structural floor slab
- 5 Pipework within vented ducting located within suspended ceiling void and sealed to ceiling board
- 6 Suspended ceiling
- 7 Pipework with factory-finished protection laid in screed above resilient overlay <sup>A)</sup>
- 8 Screed
- 9 Resilient sound-proofing overlay
- 10 Structural floor slab
- 11 Floating floor

<sup>A)</sup> Exposed metallic pipework, for example at joints, shall be further protected on site (see 8.1.7 to 8.1.12).

Figure 1D – Flexigas in timber fire compartment floors

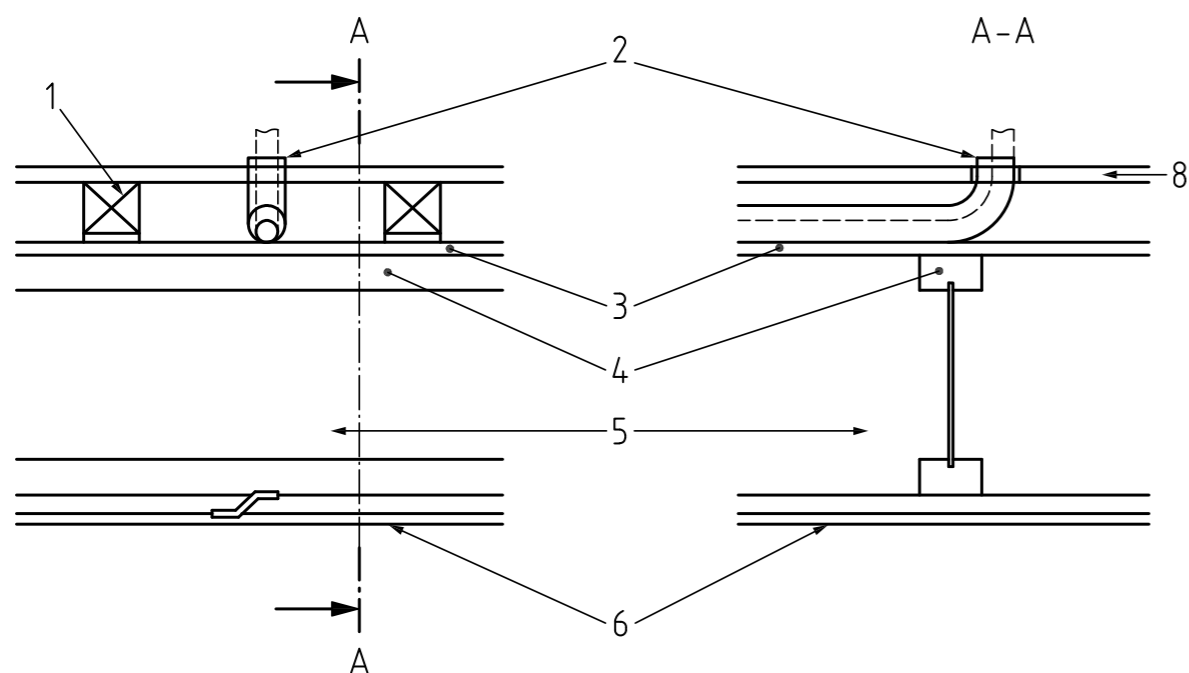

a) Typical suspended timber compartment floor

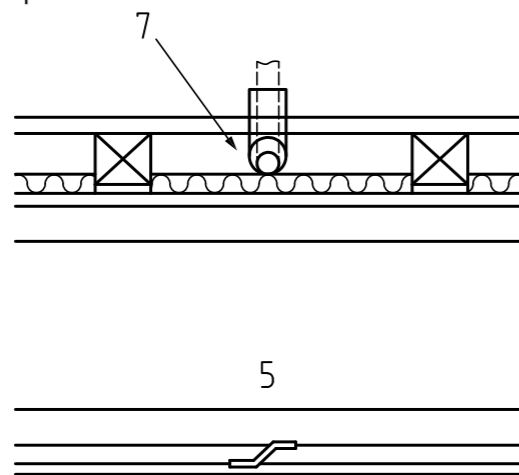

b) Typical suspended timber compartment floor incorporating resilient quilt

**Key**

- 1 Floor decking on battens on resilient bearers/pads
- 2 Pipework within vented ducting extended above floor level and sealed to floor deck with flexible sealant
- 3 Structural deck
- 4 Timber joist
- 5 No pipework in this void
- 6 Ceiling fixed to resilient bars
- 7 Ducted pipework can be above or below any resilient quilt laid between floor battens with no fixings used to secure the ducting penetrating or damaging the quilt
- 8 Floor deck

## 12 - FLEXIGAS IN SOLID FLOORS

The Flexigas plastic cover complies with section 8.10.7 of BS 6891:2015 (specifically, with regards to cover thickness and chloride content of plastic cover) and therefore the cover **meets the requirements for direct burial** (factory finished protection) and does not require additional sleeving when being placed in floor screed. However, it is important to highlight section 8.10.6 of BS 6891:2015 and Regulation 208 19(2)b) of the Gas Safety (Installations and Use) Regulations also requiring all gas pipework to be protected against damage caused by movement as best as possible (for example from subsidence, or some other structural movement).

Therefore, if the gas installer judges that the Flexigas tubing may be subject to unforeseen movement from the solid floor in which it is being placed, it is considered best practice, and optional, to place the Flexigas tubing in a suitable sleeve as per Section 14 (as may be done with rigid copper installations).

All buried pipework should be inspected for damage before being placed in a solid floor. Extra special attention should be given to any damage to the plastic cover where the installer will be installing Flexigas tubing directly in floor screed without additional sleeving. Any gaps or holes in the plastic cover should be wrapped with silicone tape with at least 50% cover to provide a layer of double thickness.

The installed Flexigas system should be tested for gas tightness before being covered by floor screed

Where a pipe is buried in a concrete screed there shall be a minimum of 25 mm of cover above the FlexiGas tubing or sleeve.

Flexigas fittings shall not be directly buried in any solid floor. If a fitting is required within the floor screed or below ground boxes with removable covers are suitable so that the fitting can be accessed if needed. They are known 'conduit junction boxes' and will be available from your local plumbing merchant.

Flexigas should never be buried in structural elements of the floor such as concrete slabs or structural toppings. Pipework shall not be buried in power-floated floors that form part of the structure. Pipework in acoustic floors shall only be installed with the agreement of the building designer.

Where pipework is to be installed in solid floors it shall run parallel or at 90° to the walls.

Examples of Flexigas laid in concrete are shown in the following diagrams.

Figure 2A - Examples of Buried Pipe – Ground Bearing Concrete Floors

Dimensions in millimetres

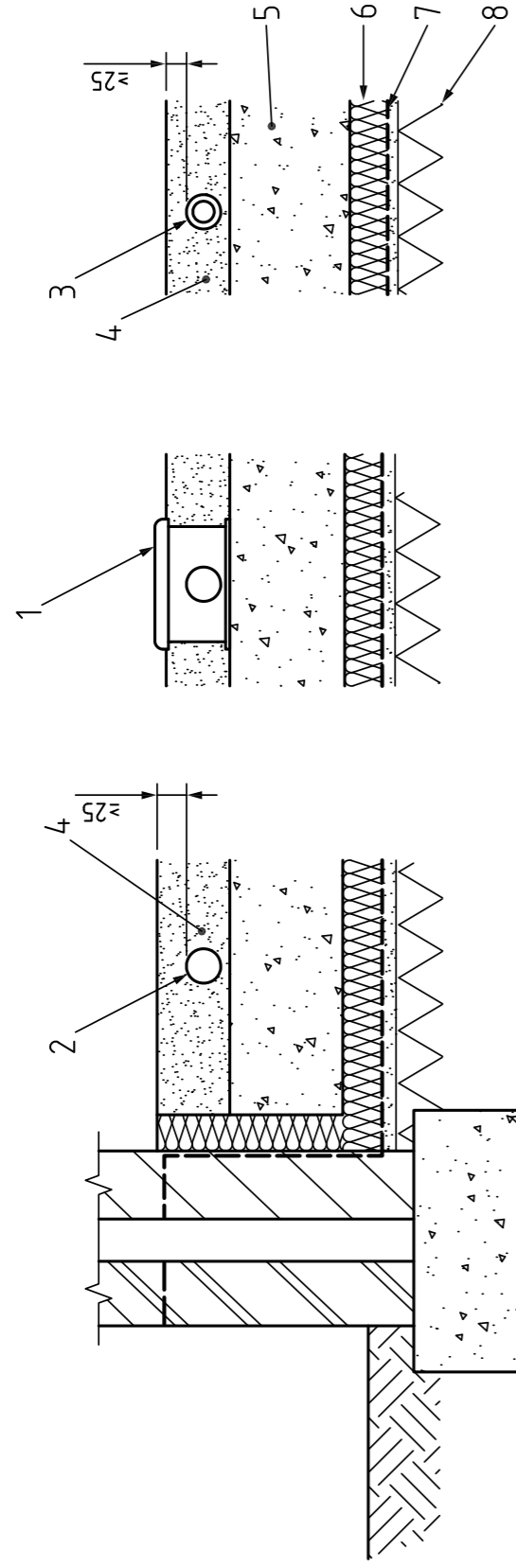

a) Ground bearing concrete floors

**Key**

- 1 Pipework laid in preformed duct
- 2 Pipework with factory-finished protection laid in screed
- 3 Pipework fitted with soft sleeving and laid in screed
- 4 Screed

- 5 Concrete slab
- 6 Insulation
- 7 Damp-proof membrane
- 8 Hardcore and sand blinding

Figure 2B - Examples of Buried Pipe – Suspended Concrete Floor

Dimensions in millimetres

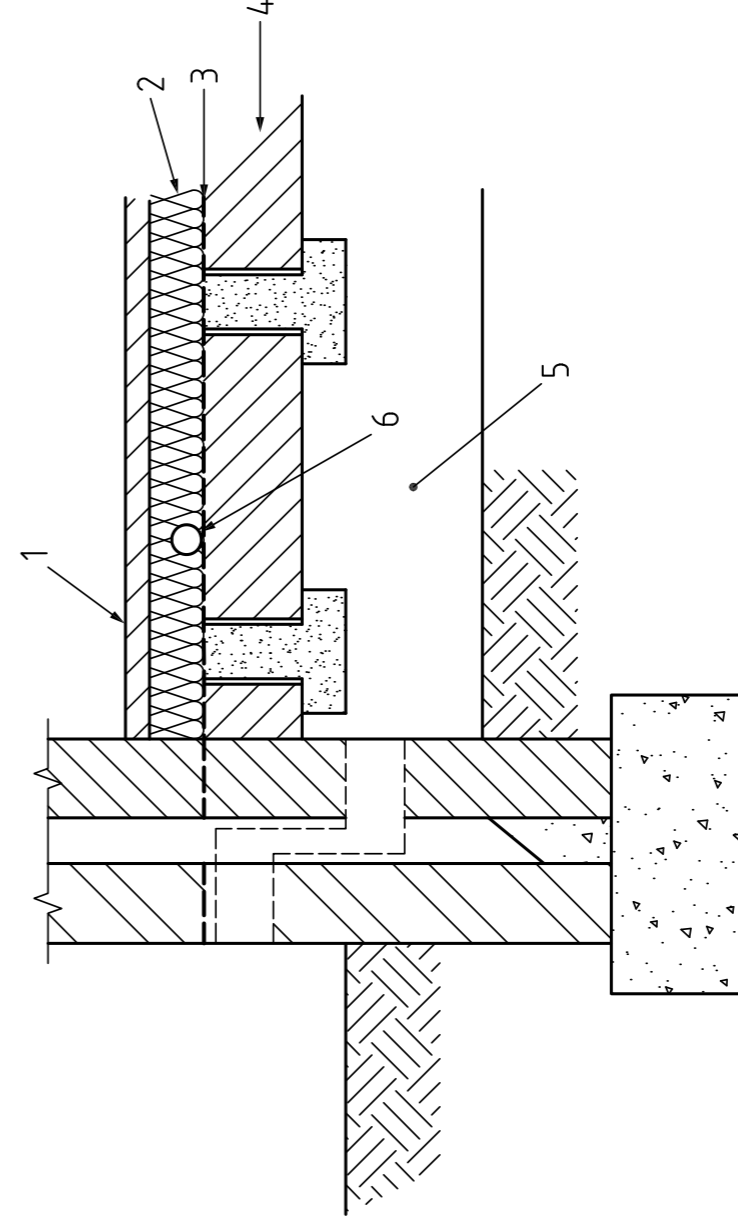

b) Suspended concrete floor

**Key**

- 1 Chipboard or floor screed over insulation
- 2 Insulation
- 3 Damp-proof membrane

- 4 Precast beam and block
- 5 Ventilated void
- 6 Pipework

Figure 2C - Examples of Buried Pipe – Concrete Rafts

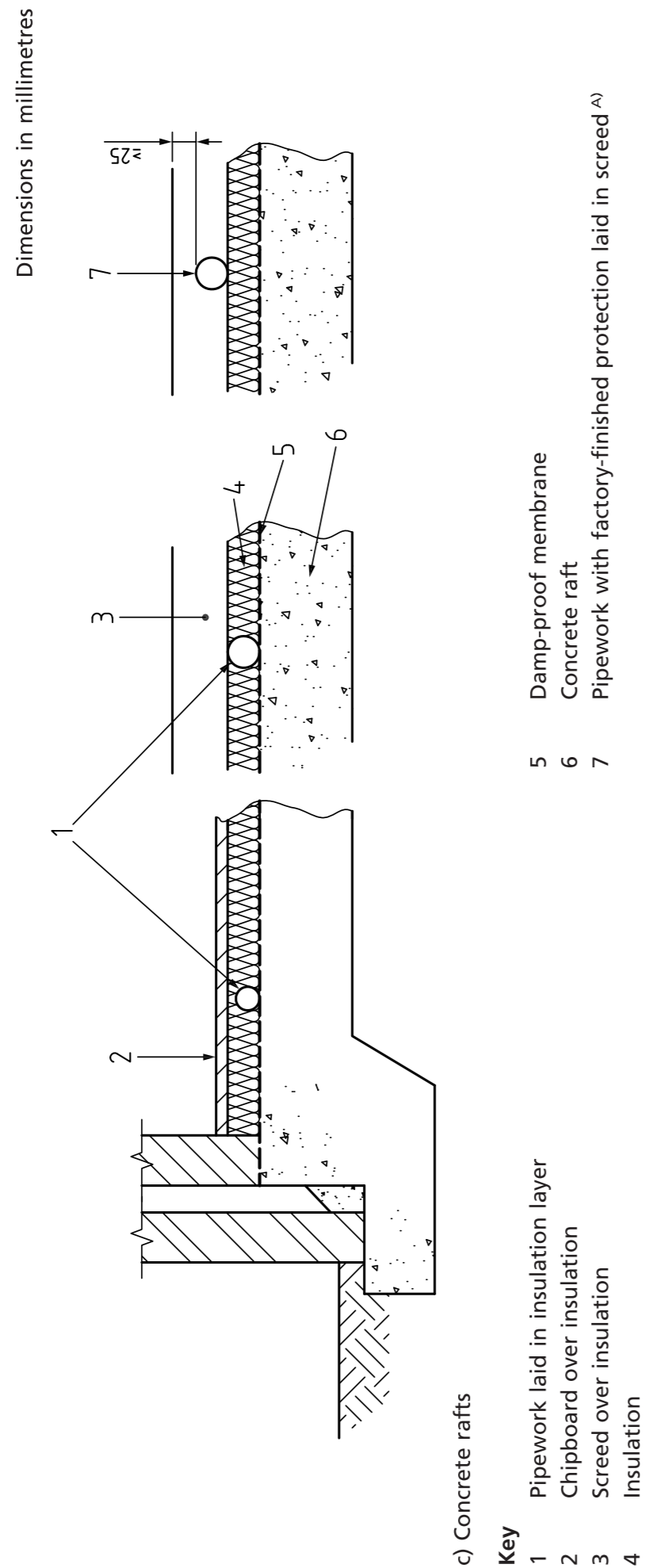

### 13 - FLEXIGAS IN WALLS

Flexigas tubing should be placed in walls by following the below procedures and diagrams.

For examples of Flexigas in timber and masonry walls please refer to the following diagrams:

- Brick and block plastered - Figure 3A
- Brick and block with dry lining on dabs - Figure 3B
- Brick and block dry lined on battens - Figure 3C
- Timber frame and light steel construction - Figure 3D

#### Additional Procedures

##### Pipe Runs

Flexigas tubing shall, where possible, be vertical and shall be placed in ducts with convenient access points or placed in pipe chases.

The installation pipe shall be secured and have as few joints as practicable.

##### Damage

Flexigas tubing should be inspected for damage before being placed within a wall. Any damage to the plastic cover can be repaired using silicone tape, with at least 50% overlap cover from one pass to the next.

##### Cavity Walls

Flexigas tubing shall not be placed within the cavities of cavity walls. Every pipe passing through a cavity wall shall take the shortest practicable route and shall be sleeved (see Section 14).

##### Dry-Lined Walls

Flexigas tubing installed behind dry lining shall be suitably encased by building material. Where Flexigas tubing passes within 50mm of the decorative face of the plasterboard, it shall be protected against penetration, for example with 1mm steel plate.

##### Timber Construction And Light Steel Framed Walls

Flexigas tubing installed within walls of timber frame construction shall:

- be run within purpose-designed channels or ducts;
- be adequately secured;
- have as few joints as practicable;
- be protected from mechanical damage
- not be in position where the tube could be penetrated by a nail or screw 50mm long. The tubing must be placed at least 50mm from the face of the plasterboard or if not behind a steel plate with min thickness of 1mm.

Flexigas passing from one side of a timber frame or light steel-frame construction to the other side must take the shortest practical route and be sleeved.

##### Solid Walls

Where Flexigas tubing passes through a solid wall it shall be sleeved (see Section 14)

Figure 3A - Brick and Block Plastered

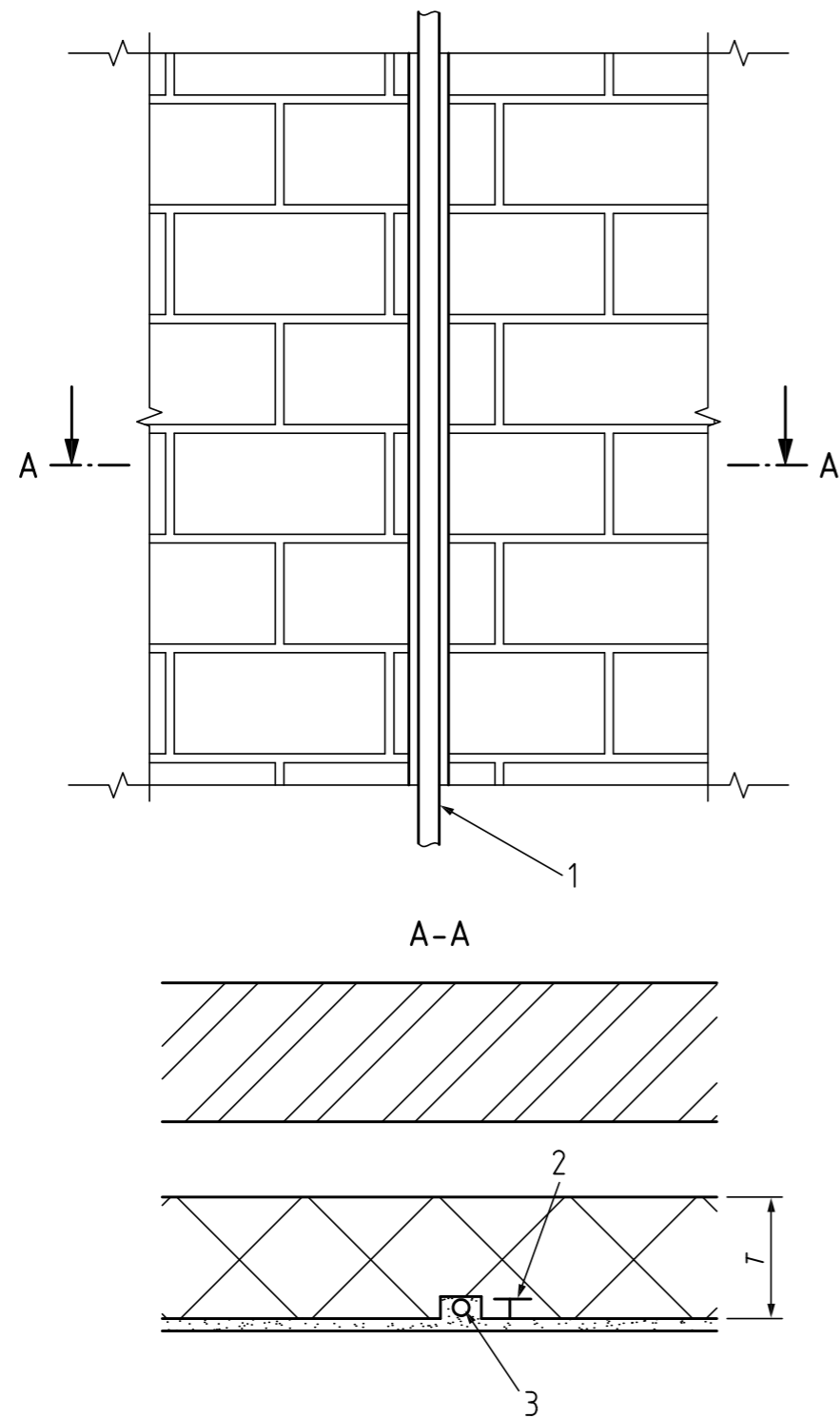

**Key**

- 1 Pipework set in chase
  - 2 Depth of chase
  - 3 Pipework set into chase in plastered wall
- Maximum depth of chase:  $T/6$  horizontal;  $T/3$  vertical

Figure 3B - Brick and Block with Dry Lining on Dabs.

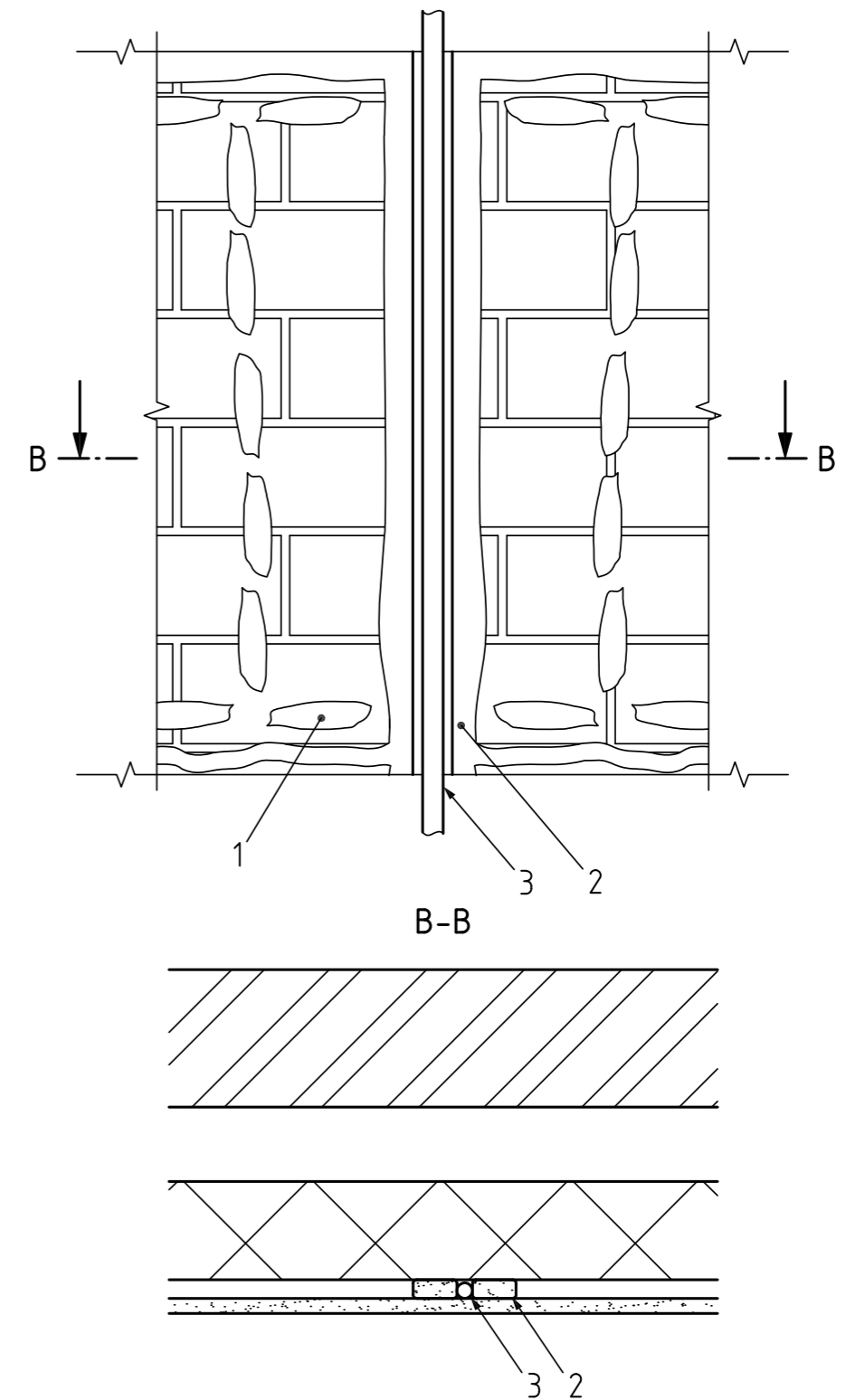

**Key**

- 1 Individual adhesive dabs
- 2 Continuous adhesive dabs to surround pipework
- 3 Pipework



Figure 3C - Brick and Block Dry Lined on Battens

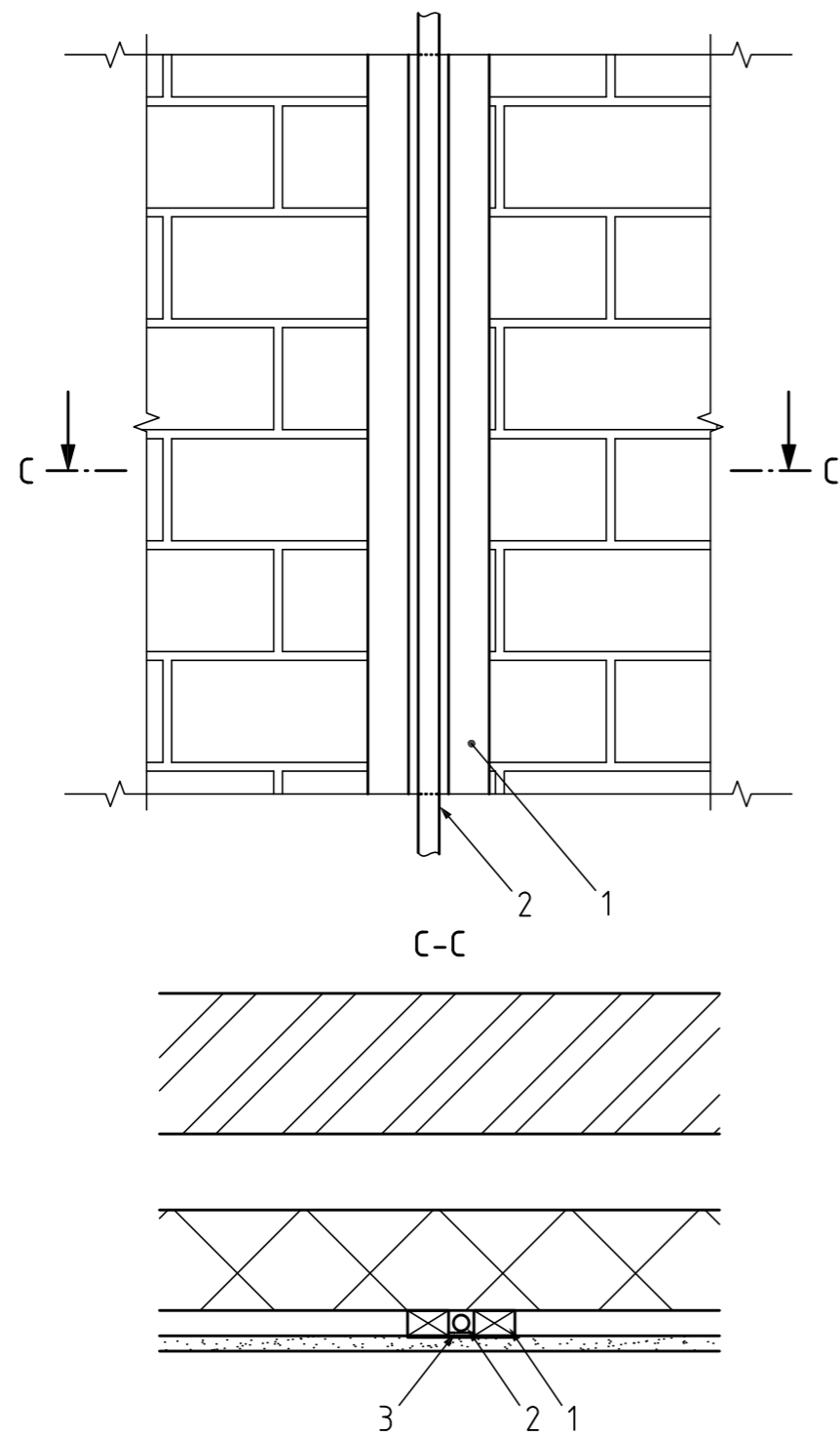

NOTE The joints between the wall and studs should be sealed with mastic in order to avoid gas tracking around the studs.

**Key**

- 1 Timber battens
- 2 Pipework
- 3 Steel plate of min. 1 mm thickness

Figure 3D-A - Examples of Flexigas installed in timber and light steel framed construction walls

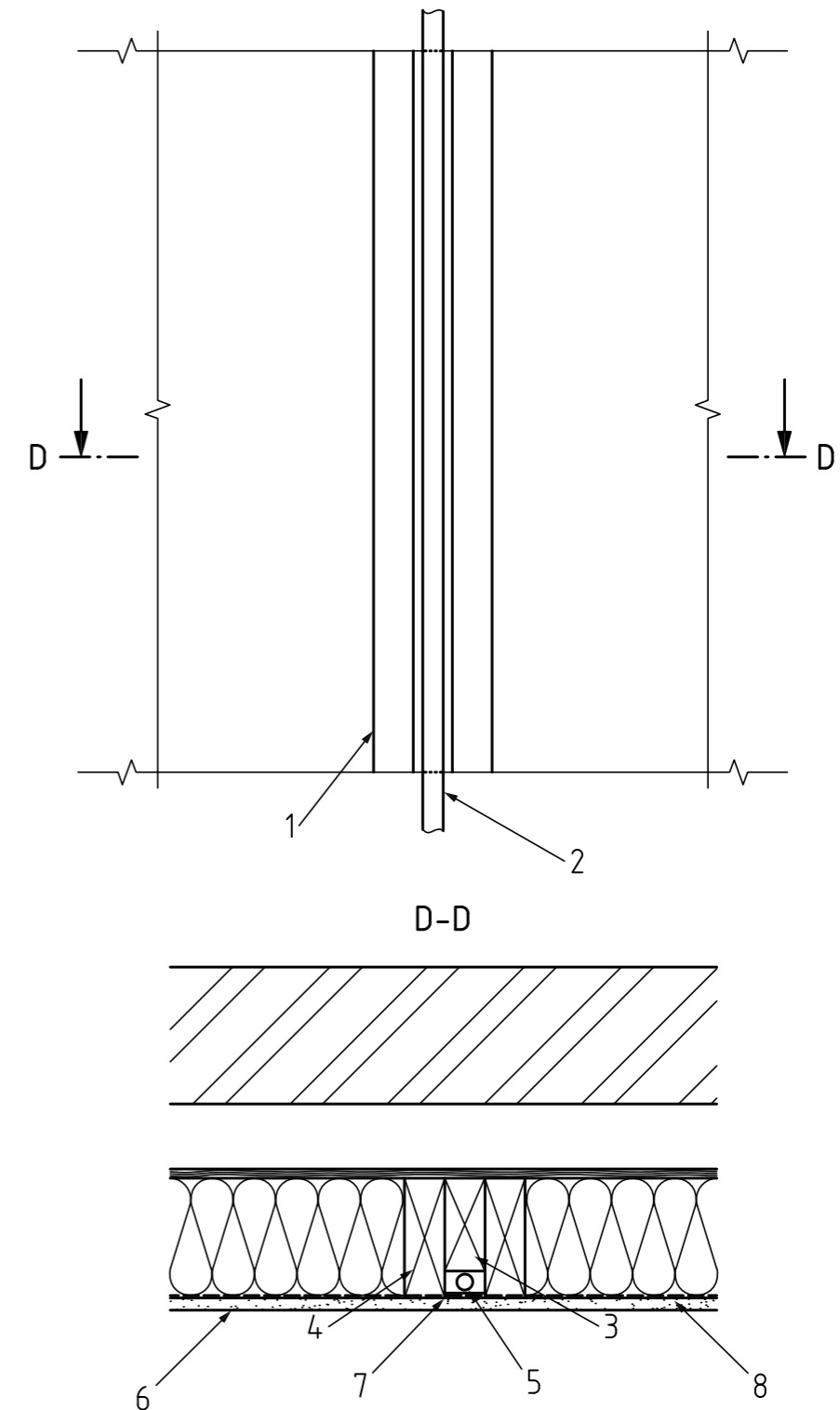

NOTE The joints between the studs should be sealed with mastic in order to avoid gas tracking around the studs.

a) Pipework passing through timber-frame wall

**Key**

- 1 Timber stud
- 2 Pipework
- 3 Timber stud blocking piece
- 4 Timber stud
- 5 Pipework
- 6 Plasterboard
- 7 Steel plate of min. 1 mm thickness
- 8 Vapour barrier

Figure 3D-B – Examples of Flexigas installed in timber and light steel framed construction walls

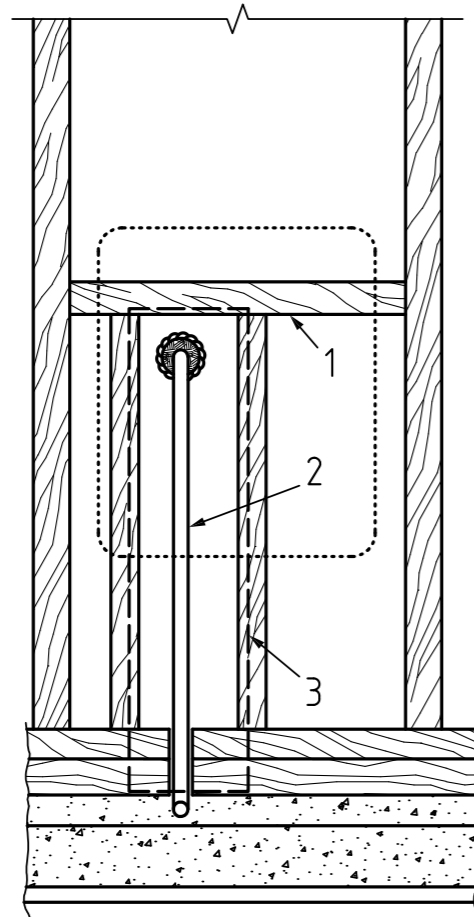

*NOTE* The joints between the studs should be sealed with mastic in order to avoid gas tracking around the studs.

b) Pipework installed in a timber-framed wall

**Key**

- 1 Timber stud
- 2 Pipework
- 3 Steel plate of min. 1 mm thickness

Figure 3D-C – Examples of Flexigas installed in timber and light steel framed construction walls

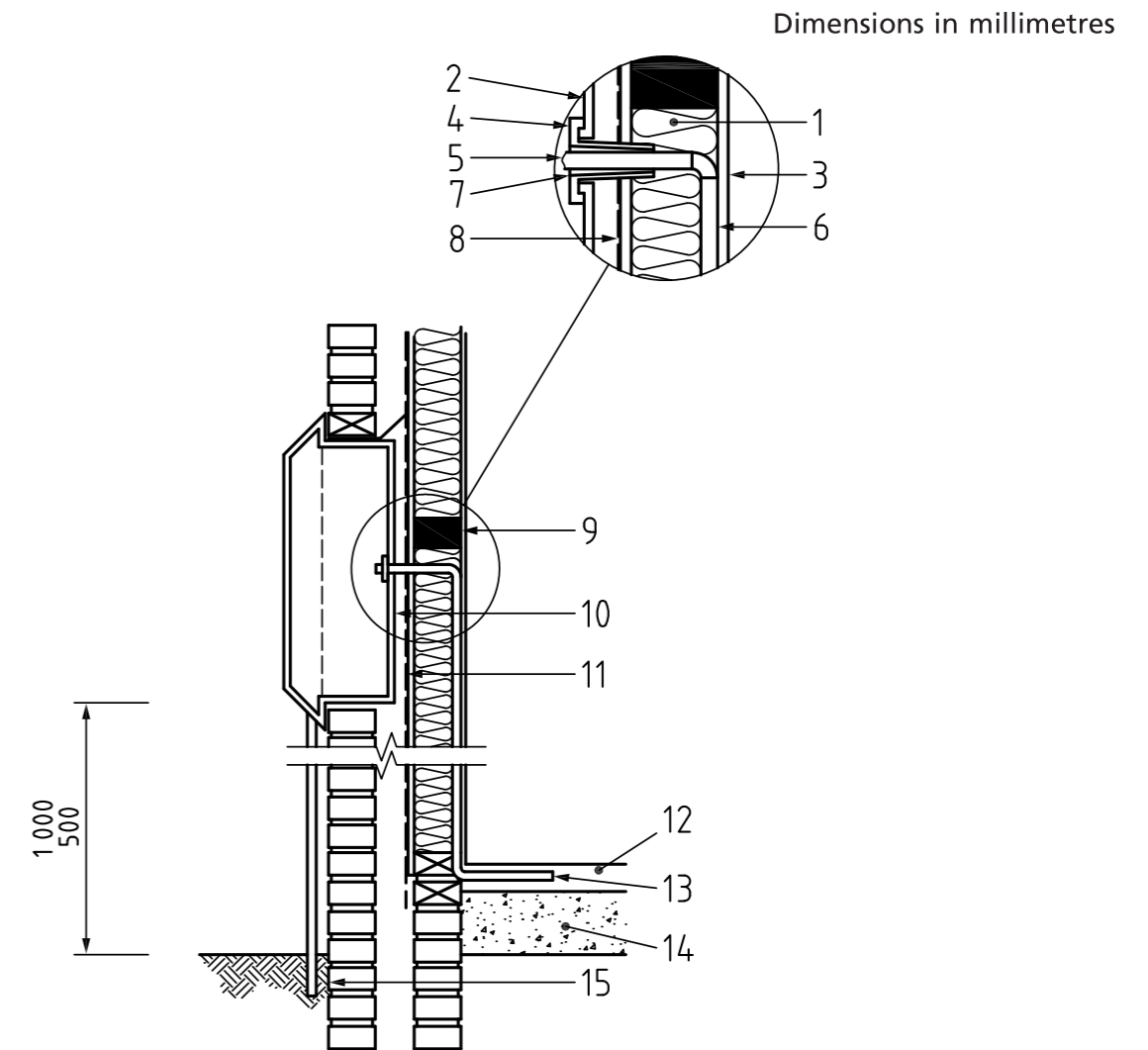

*NOTE* Pipework to be located in a channel formed by timber studs of the same depth as the timber frame [the principles for which are shown in Figure 18a) and b)]. Timber studs should be sealed with mastic.

c) Pipework entering a timber-framed/light steel-framed building from a meter box

**Key**

- |   |   |    |   |
|---|---|----|---|
| 1 | Insulation  | 10 | Air space between back of box and breather membrane |
| 2 | Meter box wall  | 11 | Breather membrane carried down behind meter box     |
| 3 | Plasterboard  | 12 | Floor screed  |
| 4 | Rear spigot   | 13 | Pipework from meter notched through sole plate      |
| 5 | Pipework (protected by a steel plate of min. 1 mm thickness as necessary) | 14 | Preservative treatment to sole plate made good      |
| 6 | Vapour control layer  | 15 | Concrete  |
| 7 | Mastic sealing  |    |   |
| 8 | Timber sheathing  |    |   |
| 9 | Timber stud   |    |   |

Figure 3E- Typical method of accommodating movement through a masonry/timber frame wall

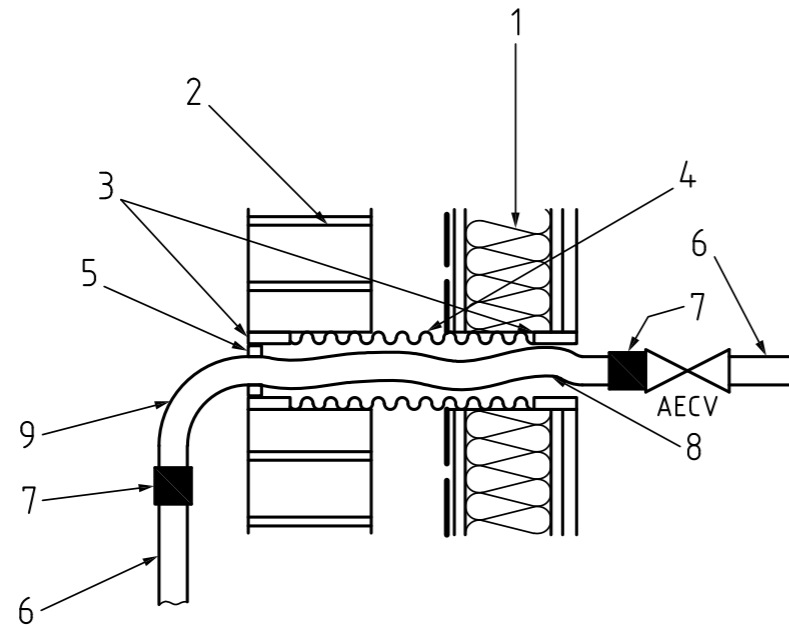

a) As installed: before movement of timber

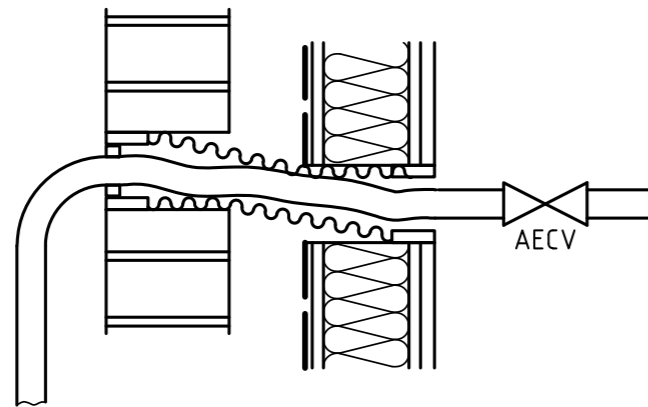

b) After relative movement of timber

**Key**

- 1 Timber frame
- 2 Masonry external wall or wall of internal riser duct
- 3 Sealant between sleeve and wall
- 4 Flexible pipe sleeving
- 5 Flexible sealant on one end of sleeve only, preferably external side to prevent water ingress
- 6 Rigid pipe
- 7 Transition fitting from rigid pipework to pliable corrugated (stainless-steel) tubing
- 8 Pliable corrugated (stainless-steel) tubing
- 9 Bend not to exceed manufacturer's recommendation

**14 - SLEEVES**

Sleeves shall be of a material capable of containing gas, e.g. copper, steel, polyethylene (PE) or polyvinyl chloride (PVC).

Pipework passing through a wall or a floor, whether or not it contains a cavity, shall pass through sleeve.

Sleeves shall pass through the full width of the wall or the full thickness of the floor. Sleeves shall not impair the fire resistance of a building. The annular space between the pipe and the sleeve shall be sealed at one end to the pipe with a flexible fire resistant compound. Where a sleeve passes through an exterior wall, the seal shall be on the inside of the wall.

The internal diameter of any sleeve should allow for an annular space around the pipe to enable satisfactory insertion of the pipe into it and be of sufficient diameter to allow adequate sealing between the pipe and the sleeve.

Flexigas fittings shall not be located within the sleeve.

The outside of the sleeve shall be secured and sealed at each end to the structure of the building with a suitable building material, e.g. cement mortar.

## 15 – FLEXIGAS IN DUCTS / VENTILATION

Vertical and horizontal ducts containing Flexigas tubing are required to be ventilated to ensure that minor\* gas leakage does not cause the atmosphere within the duct to become unsafe.

The duct may run freely through a number of storeys or take the form of an enclosure at each storey level. Where ducts are continuous, ventilation can normally be achieved by the provision of openings sized in accordance with the table below. Where the duct takes the form of an enclosure at each storey level, ventilation is normally required at high level only in each storey (see Figures 4A & 4B).

The following table gives ventilation requirements for different duct sizes.

<u>Cross sectional area of duct (m<sup>2</sup>)</u>	<u>Minimum free area of each opening (m<sup>2</sup>)</u>
Not exceeding 0.01	0
0.01 and not exceeding 0.05	Cross sectional area of duct
0.05 and not exceeding 7.5	0.05
Exceeding 7.5	1/150 of the cross sectional area of the duct

Please Note:

Ducts having a small cross sectional area and volume (i.e. 0.01m<sup>2</sup> or less with a total volume of less than 0.1m<sup>3</sup>) are considered to be adequately ventilated by adventitious means and no additional openings are required.

Flexigas tubing may be installed in an unventilated duct where it is sleeved as per Section 14. Flexigas should not be placed in any metallic duct or chase that includes a metallic appliance vent or chimney that protrudes through or past the roof.

The normal minimum period of fire resistance of the duct is 30 min for buildings of not more than three storeys. Further guidance on the fire resistance of buildings is given in the appropriate Building Regulations. The fire resistance of any duct containing Flexigas shall have a fire rating equal to or greater than any void through which it passes.

\*Minor gas leakage is that which would remain undetected by normal gas tightness testing techniques. The level of ventilation is not intended to clear a major gas escape arising from damage or failure of a gas pipe.

## 16 - FIRE PROTECTION/STOPPING

For buildings containing flats and/or maisonettes, Flexigas installations shall be fire stopped as they pass from one floor to another unless in their own protected shaft that is ventilated top and bottom to outside air.

When installation pipes from a continuous duct enter a flat or maisonette they shall be fire stopped at the point of entry.

Where pipework passes through an individual dwelling or commercial unit other than the one it supplies, it shall be located within a purposely constructed duct to prevent damage to the pipework.

The fire resistance of any duct containing gas pipework should have a equal or greater fire rating as any void through which it passes.

Examples of typical installation pipework in multi-storey buildings containing flats or maisonettes are given in Figures 4A & 4B.

### Best Practice In Regards To Fire Stopping

When pipes pass through the protecting structure (i.e. compartment walls or floors) all openings should be kept as small, and as few in number, as practicable, and should be suitably fire stopped in such a manner as to allow thermal movement of the pipe and ensure the fire resistance is not impaired. To prevent displacement, materials used for fire stopping should be supported by, or reinforced with, materials of limited combustibility. Any proprietary fire stopping should, when tested in accordance with the appropriate part of BS 476, achieve the relevant periods of fire resistance for the structure in respect of load bearing capacity, integrity and insulation.

Figure 4A - Typical installation pipework in multi storey buildings containing flats or maisonettes –  
Ventilated duct.

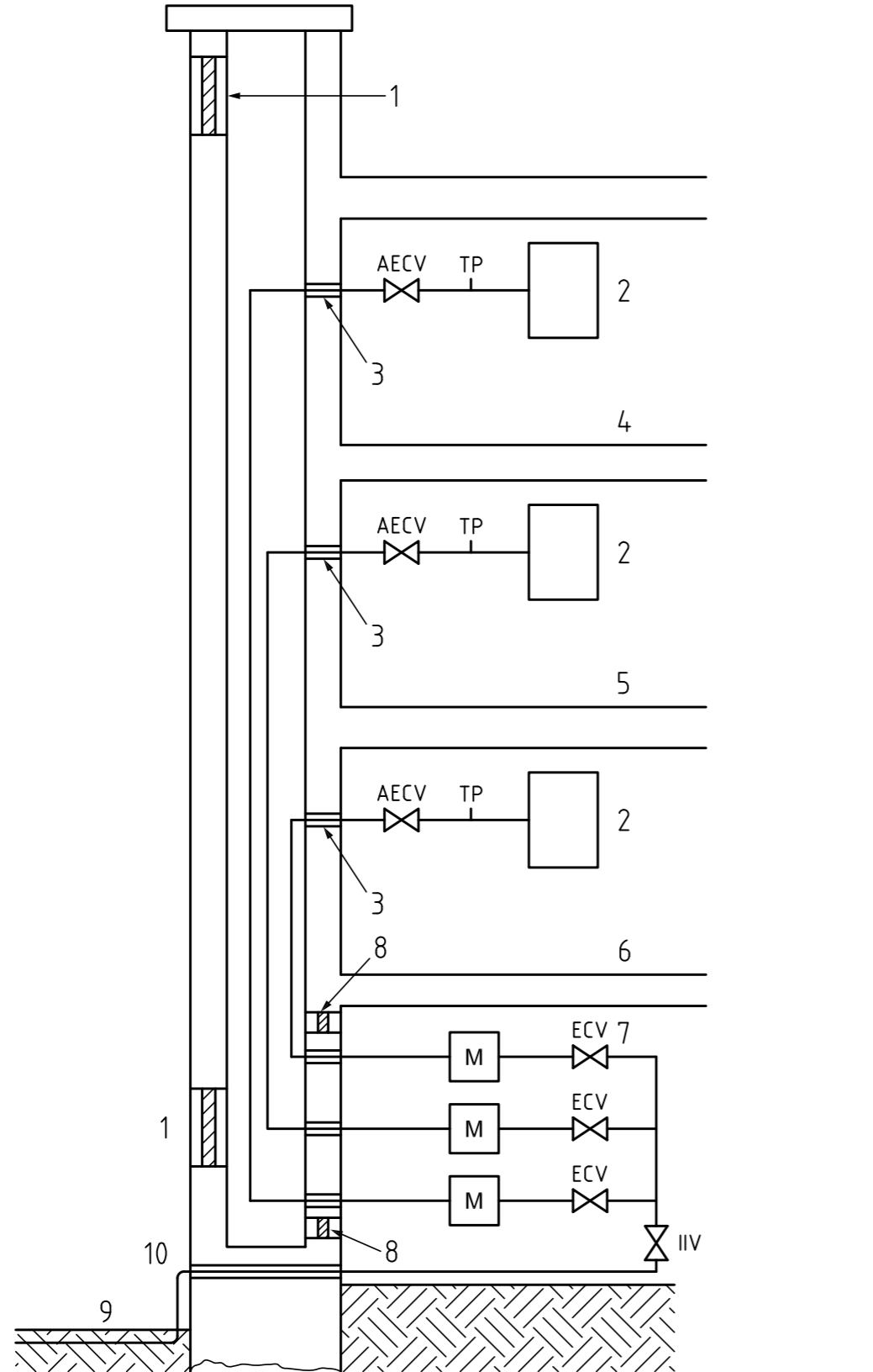

a) Ventilated duct

<b>Key</b>	1 Ventilation	6 Flat 1	ECV Emergency control valve
	2 Appliance	7 Meter room	AECV Additional emergency control valve
	3 Fire stop	8 Meter room ventilation	IIV Inlet isolation valve
	4 Flat 3	9 Ground level	M Gas meter
	5 Flat 2	10 Gas service	TP Test point

Figure 4B - Typical installation pipework in multi storey buildings containing flats or maisonettes –  
Fire stopped pipework and a ventilated enclosed area.

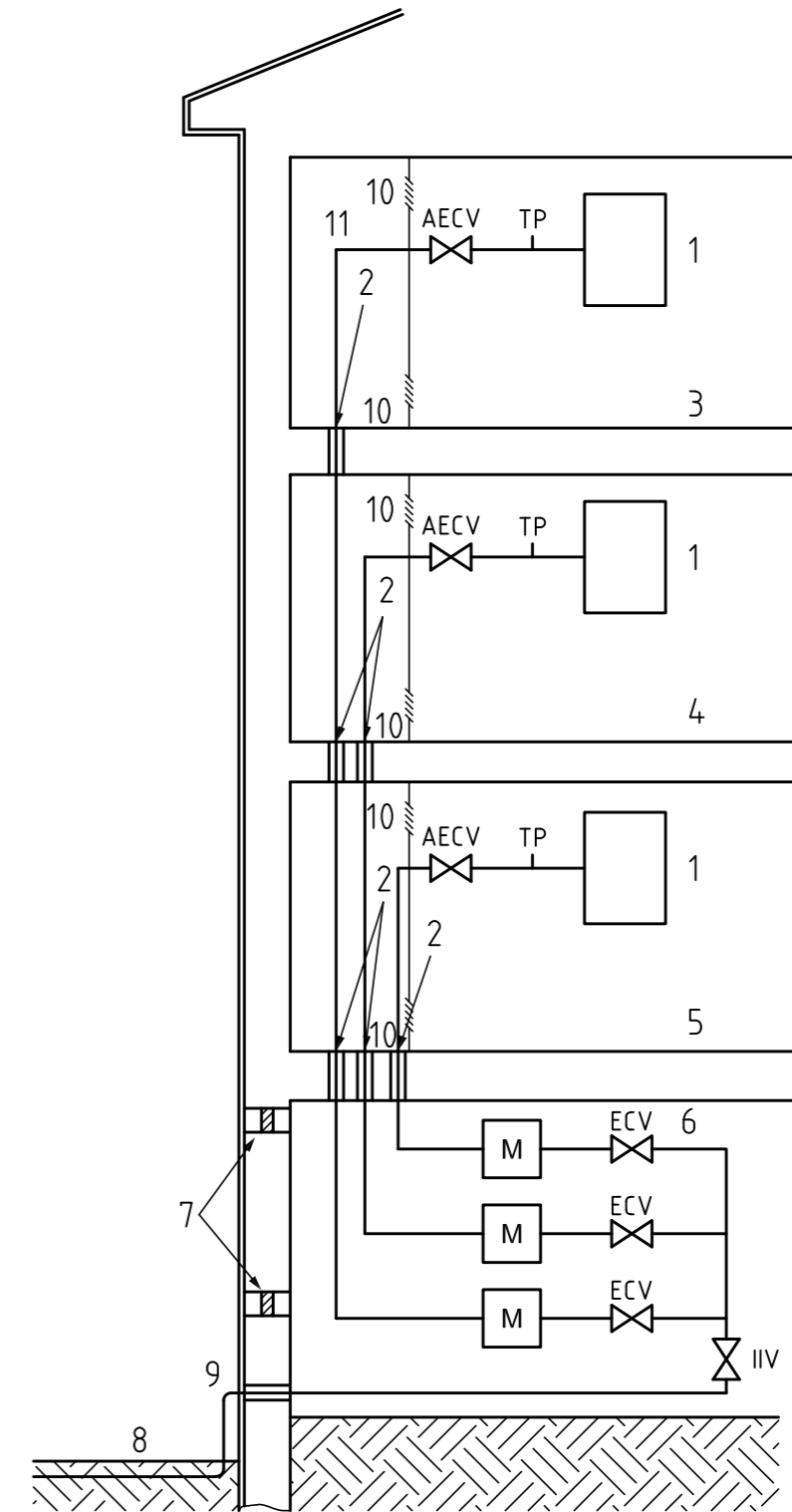

b) Fire stopped pipework and ventilated enclosed area

<b>Key</b>	1 Appliance	6 Meter room	11 Enclosure
	2 Fire stop	7 Meter room ventilation	ECV Emergency control valve
	3 Flat 3	8 Ground level	AECV Additional emergency control valve
	4 Flat 2	9 Gas service	IIV Inlet isolation valve
	5 Flat 1	10 Vent	M Gas meter
			TP Test point

NOTE Vents are to communicate with an area that is ventilated in accordance with the Building Regulations [5], [6], [7].

## 17 - PIPE SUPPORTS

Flexigas CSST tubing should be supported by the following maximum distance between pipe supports.

Nominal Size	Vertical Run	Horizontal Run
DN 15	1.2m	1.2m
DN 22	1.8m	1.8m
DN 28	1.8m	1.8m
DN 32	2.5m	2.5m
DN 40	2.5m	2.5m
DN 50	2.5m	2.5m

## 18 - EXTERIOR PIPEWORK

The Flexigas cover has been tested to both EN 15266 and BS 7838 (withdrawn and replaced by EN 15266) to specifically meet the requirements for direct burial.

Where Flexigas is installed underground the user should check the cover for any holes or gaps and cover with self adhesive silicone tape with at least 50% per pass (to ensure a double layer) to prevent corrosion from the surrounding soil.

Flexigas installed in soil, gardens or under areas with no vehicular traffic shall have at least 375mm of cover. Flexigas installed below drives with light vehicular traffic shall be at least 475mm & for drives with heavy traffic shall be at least 600mm.

For more information on how to bury all gas pipework including Flexigas please see BS6891:2015 section 8.13

Flexigas fittings shall not be installed below ground.

Flexigas is suitable for use where it is exposed. The cover is UV stable and as such no further protection or labelling is not required. As above, the installer should check to ensure there are no holes in the protective layer. The user shall also ensure that the gap between the cover and the fittings is properly covered with self-adhesive tape.

For commercial or LPG installations please consult the relevant standards.

Examples of typical exterior pipework is shown in Figure 5

Figure 5 - Typical exterior pipework with 375mm cover

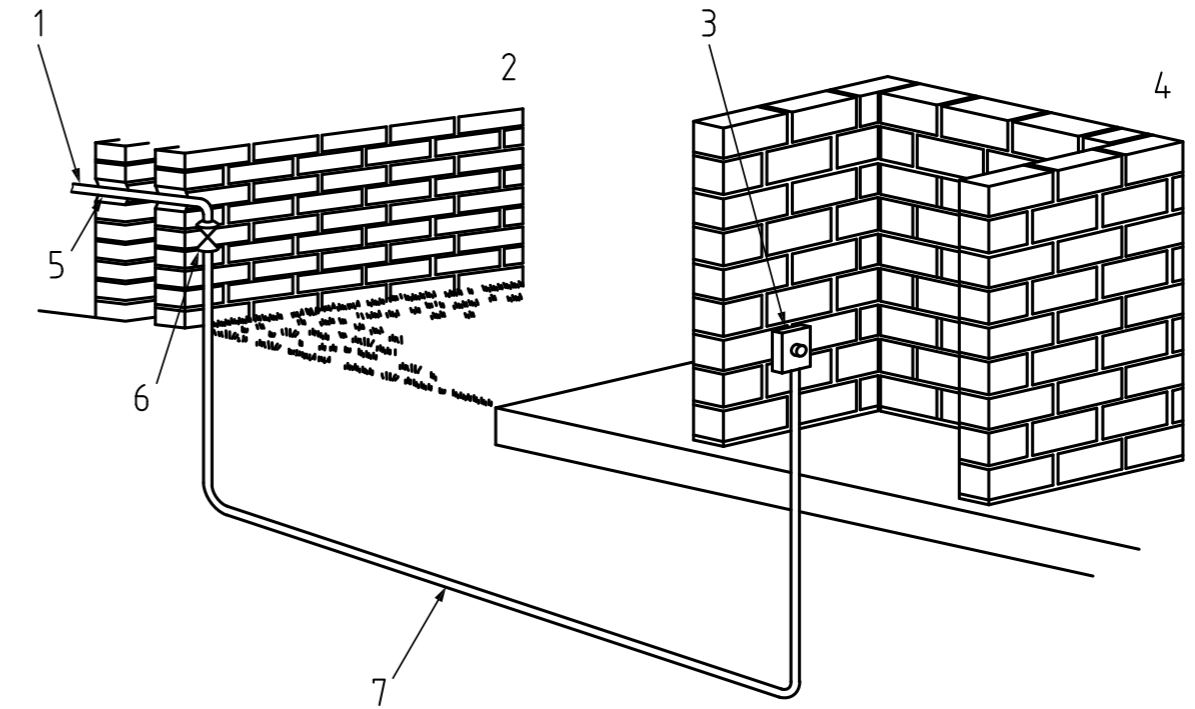

### Key

- |   |                                 |   |                                   |
|---|---------------------------------|---|-----------------------------------|
| 1 | Gas supply to external location | 5 | Pipe sleeve                       |
| 2 | House wall                      | 6 | External pipework isolation valve |
| 3 | Leisure point                   | 7 | Pipework                          |
| 4 | Barbecue                        |   |                                   |

## 19 - INTERRELATION WITH OTHER SERVICES

Installation pipework shall be located or electrically insulated so that it does not touch metallic fittings which can give rise to electrolytic corrosion. The Flexigas polyethylene cover and silicone tape should provide adequate protection where spacing is impracticable.

Where installation pipework is not separated by electrical insulating material, they shall be spaced as follows:

- at least 150mm away from electricity meters and associated excess current controls, electrical switches or sockets, distribution boards or consumer units;
- at least 25mm away from electricity supply and distribution cables.

Care shall be taken not to damage any electrical conductor when installing pipework. Installation pipes shall not be buried in floors together with electrical underfloor heating, unless the underfloor heating has been physically and permanently disconnected.

## 20 - MAIN EQUIPOTENTIAL BONDING

All domestic gas installations (including CSST systems such as Flexigas) shall have main equipotential bonding of the gas installation pipework conforming to BS 7671.

**The integrated Flexigas CSST earthing terminal has been tested by British Standards to meet the requirements of BS 951:2009 for use as a bonding clamp, and therefore meets the requirements of BS 6891 and BS 7671 for equipotential bonding of gas pipework.**

The integrated Flexigas CSST earthing terminal makes earth bonding easier, but need not be used if another suitable BS 951:2009 bonding clamp is used instead.

The purpose of electrical bonding is to create a zone in which voltage differences, and therefore hazards from electric shocks, are minimized. This is achieved by connecting separate conductive components together with a main equipotential bonding conductor or metal pipework. If an electrical fault occurs, either inside or outside of a building, it is possible for stray currents to be transmitted through the gas installation pipework.

With a PME (protective multiple earth) system, a small current may pass along the pipework under normal conditions. Therefore, to avoid electric shock, or a spark which could ignite the gas, it is important to maintain electrical continuity in the pipework at all times.

Main equipotential bonding shall be connected:

- as near as practicable to the point of entry into premises;
- before any branch in the installation pipework;
- in a position where it is accessible, can be visually observed, and fitted with a warning label stating "Safety electrical connection. Do not remove.";
- by a mechanically and electrically sound connection which is not subject to corrosion.

**If the Flexigas Integrated earthing terminal is being used:**

Attach the earthing terminal to the nut following the instructions on page 13. The warning label "SAFETY ELECTRICAL CONNECTION - DO NOT REMOVE" must be installed between the earthing terminal and the nut. The plastic notice has a small hole, through which the earthing terminal can be passed.

**If a different BS 951 bonding clamp is being used:**

The main protective bonding conductor must not be attached to the Flexigas tubing (i.e. the stainless steel tubing) directly (nor any flexible connector that may be in use near the meter). The bonding clamp may only be attached to the hex part of the fittings, or to copper or rigid steel parts of the gas installation

Main equipotential bonding of the gas installation pipework should be made using cable with minimum cross-sectional area of 10 mm<sup>2</sup> cable with green and yellow insulation, construction reference 6491X conforming to BS 6004.

For internal meters, for verification purposes the bonding connection should be within 600 mm of the meter outlet.

**The correct earth bonding of CSST systems like Flexigas is a key safety requirement of the system.**

Where the installer is not competent to make the earth bonding connection, Regulation 18(2) of the Gas Safety (Installation and Use) Regulations 1998 requires that any person who connects any installation pipework to a primary meter, has to inform the responsible person for the premises that such bonding should be carried out by a competent person.

A typical form of notification is a letter or card, an example of which is given below.

### MAIN PROTECTIVE BONDING CONDUCTOR

Most electrical installations are required to be fitted with a main protective bonding conductor, which consists of the electrical connection of the internal gas and water pipes to the installation's main earthing terminal in accordance with the requirements of BS 7671, *Requirements for electrical installations* (IET Wiring Regulations).

The gas installation pipework fitted in your premises does not appear to have the necessary main protective bonding conductor.

I am required by The Gas Safety (Installation and Use) Regulations 1998 to tell you that any necessary main protective equipotential bonding should be carried out by a competent person.

I advise you to have this checked by a competent electrical operative.

If you are the tenant of this property, please bring this matter to the attention of the owner or their agent as soon as possible.

Figure 6 - Position of main equipotential bonding connection

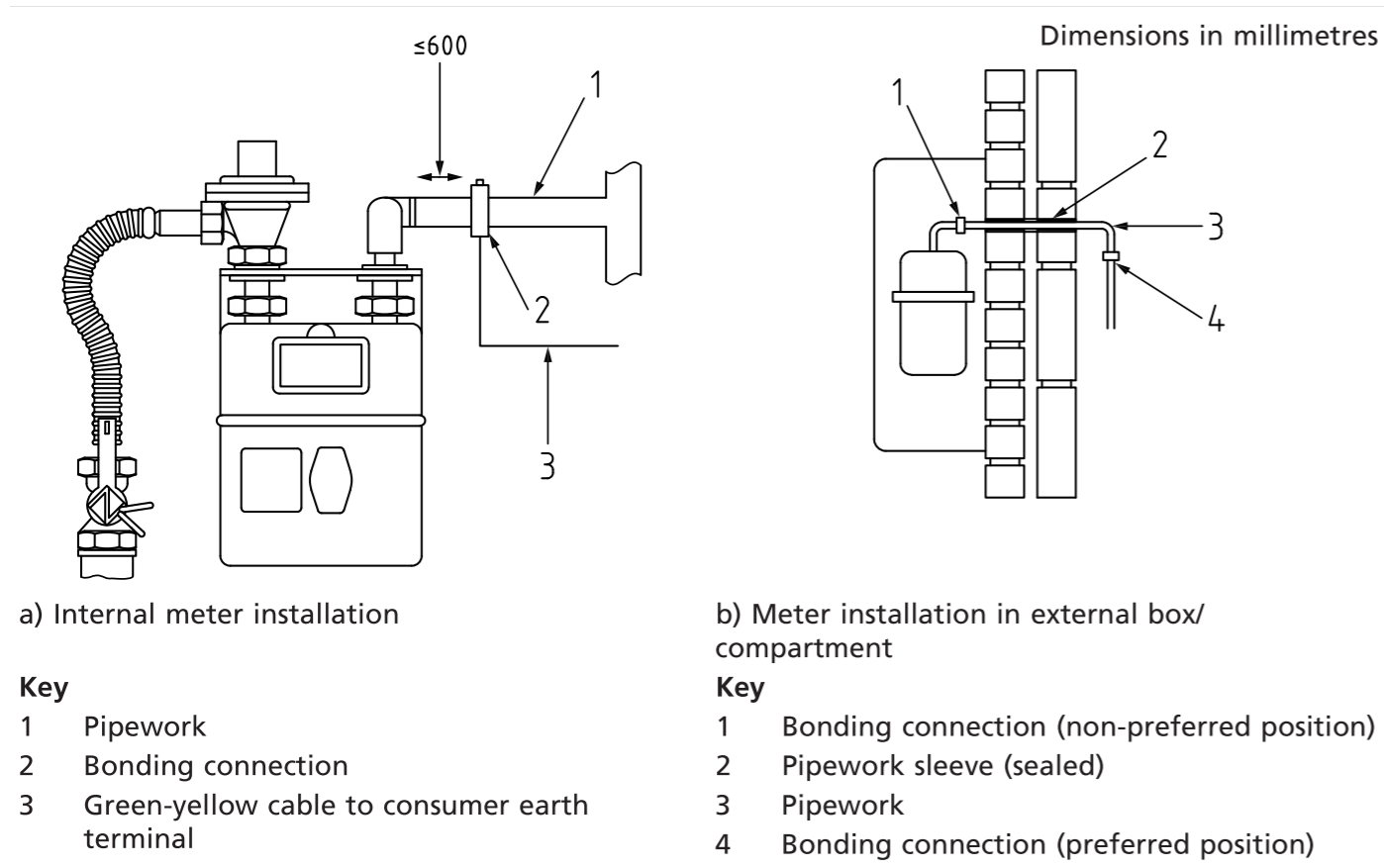

*NOTE For medium-pressure fed meter installations the main protective bonding conductor should only exit the box as detailed in BS 6400-2 and BS 6400-3.*

**21 - VALVES (EMERGENCY CONTROL VALVES)**

An Emergency Control Valve (ECV) should always be fitted. An ECV is not part of the installation pipework. It is usually installed at the end of the service main at the inlet of the primary meter.

An additional emergency control valve (AECV) shall be fitted:

- to the installation pipe where it enters the building if the meter is sited 6 m or more away from the building; or
- inside individual flats served by a large single or multiple meter installation located in a remote or communal area (see also Section 16 - Fire Stopping).

Every AECV shall:

- be labelled or marked to show its open and closed position;
- be fitted in an accessible position;
- be easy to operate;
- be fitted with a suitable handle which is securely attached, or other permanent means of operation;
- where the lever moves in the vertical plane, move to the “off” position in a downward direction.

On every AECV there here shall be a permanent notice attached to the valve giving the following information:

- the valve is an “emergency control for customers’ use”;
- details of the parts of the installation isolated by the valve;
- the telephone number of the Gas Emergency Service; and
- advice to the customer on actions to be taken if they think they can smell gas.

A pressure test point shall be installed no more than 300 mm downstream of the AECV.

Where the installation pipe is taken from inside a building to supply an appliance situated externally, a valve shall be installed in an accessible position where the installation pipe leaves the building. It is preferable that the valve be fitted externally.



## 22 - PREVENTION OF CORROSION

Flexigas shall not be installed in a position where it is likely to be exposed to a corrosive environment. The Flexigas yellow cover will provide adequate protection against corrosion in the majority of installation environments. The installer however must take special care to ensure that all exposed parts of the stainless steel are adequately protected either by means of the cover or by wrapping with silicone tape. Any exposed stainless steel around the fitting should be wrapped with self bonding silicone tape, as should any gaps or holes in the plastic cover, to ensure that no stainless steel is exposed.

Assembled pipework should be tested for gas tightness (in accordance with Section 23 before any additional protection against corrosion is applied on site.

Special care should be taken to check the integrity of the cover when burying the pipework with any gaps or holes wrapped with at least 50% overlap. This should be done after performing the gas tightness test.

When applying the tape ensure the pipe is clean and dry. A minimum of 50 % overlap should be used when wrapping the pipe to provide a layer of at least double thickness.

Where possible, wrapping should be coloured yellow ochre in accordance with BS 1710.

### Pipework In Fireplace Openings

CSST such as Flexigas are not suitable for use in the openings of all-fuel fireplaces as Soot and debris can be particularly corrosive. Flexigas being used in such a scenario must be terminated outside the firebox with the final installation being made with a suitably protected pipe.

## 23 - GAS TIGHTNESS TESTING AND PURGING

Upon completion of the installation and prior to gas being made available, the installation shall be tested for gas tightness and purged in accordance with IGE/UP/1B – Tightness testing and purging of domestic sized natural gas installations (or other applicable standard).

**Self-bonding silicone tape should only be applied to any gaps/holes on the cover, and to the area around the fittings after the gas tightness testing has been conducted.**

Some leak detection fluids may be corrosive to the components of Flexigas (i.e. stainless steel and brass) and should not be used. In particular chemicals with a high chloride content (such as soaps) should be strictly avoided.

Whenever a gas supply system is being commissioned or re-commissioned it must be purged as per IGEM/UP/1A or 1B. This includes conducting a tightness test as above.

To calculate the total internal volume of a pipework installation that includes Flexigas, the following table can be used, and in conjunction with an appropriate method as outline in IGEM/UP/1.

Size	m3 volume of 1m length of Flexigas
DN 15	0.00020
DN 22	0.00043
DN 28	0.00068
DN 50	0.00098
DN 40	0.00162
DN 50	0.00236

Where it is not possible to purge through an appliance, an appropriately sized purge point needs to be provided (see IGEM/UP/1).

## 24 - CONNECTION OF FLEXIGAS TO OTHER SYSTEMS

The Flexigas system can only be connected to other piping systems by means of approved BSP thread fittings.

Flexigas tubing is only compatible with Flexigas fittings. No Flexigas components should ever be connected directly with any other CSST systems despite how similar they may appear.

Where soldered components are to be joined to Flexigas (by means of a thread fitting) the solder work should be done well before any Flexigas component is brought within the vicinity of where the connection is to be made. Before attaching the Flexigas fitting ensure that the corresponding thread is cleaned, dry and free from any solder flux residue.

## 25 - DAMAGE AND REPAIR

Despite its weight Flexigas is quite resilient. However, the installer should still take special care not to damage the components of the system, either in storage or installation.

Where damage has occurred to the cover, it can be repaired by use of self bonding silicone tape. The tape should be wrapped around the pipe so that there is at least 50% overlap from one pass of the tape to the next. Any damage to the cover should be repaired after gas tightness testing.

Where damage to the tubing has occurred the damaged piece of tube should be removed from the pipe run. A section of tubing should be replaced where:

- The tubing has been punctured (i.e. by a nail, drill, screw)
- The tubing has been bent beyond its minimum bend radius.
- The tubing has been significantly crushed to the point where it will restrict flow.
- The tubing has been exposed to a corrosive chemical or material.

Where damage occurs in a pipework section where fittings are not permitted (i.e. in section of tubing that is to be placed in the ground or a wall) it will be necessary to replace the whole tubing run, or at least take the tubing run back to a location where fittings are permitted.

If the damaged section of tubing occurs in a portion of the pipework where fittings are permitted then it will be possible to repair the tubing run by removing the damaged component and joining the two sections of tubing together by use of a Flexigas Union fitting. The installer should be careful however not to put excessive strain on other parts of the pipework when trying to join these sections together. Where a larger section of Flexigas tubing has been damaged, the damaged section can be replaced by use of two Flexigas Union fittings and an additional piece of Flexigas tubing.

## 26 - WARRANTY

Flexigas Europe Ltd warrants that all components of the FlexiGas™ system are free from defects and that if any such defect should be discovered a replacement component will be provided up to 25 years from the date of purchase. This warranty is limited to making a replacement component available and does not include or cover any labour cost involved or connected therewith (including but not limited to diagnosing the defective component and/or removing and reinstallation of said defective component).

This warranty does not apply to any defective component that is considered unfit for purpose or defective due to improper installation, storage, transportation or general misuse (either through negligence or otherwise), nor does this warranty extend to any loss or damage caused by events outside the direct control of Flexigas Europe Ltd (including but not limited to improper storage or transportation, floods, fires and other acts of God). This warranty is in lieu of any other warranties expressed, implied or statutory.

## 27 - GAS PIPEWORK INSIDE A PROTECTED AREA

Flexigas that is installed in one continuous length (with no fittings) meets the requirements of BS 6891 to be installed in a protected area, such as a protected corridor or lobby without additional ventilation (such as a dedicated fire proof duct), provided that the protected area is deemed “normally occupied”.

A normally occupied area is a part of the building or dwelling where it reasonably expected for people to be in the vicinity, such as a common stairwell.

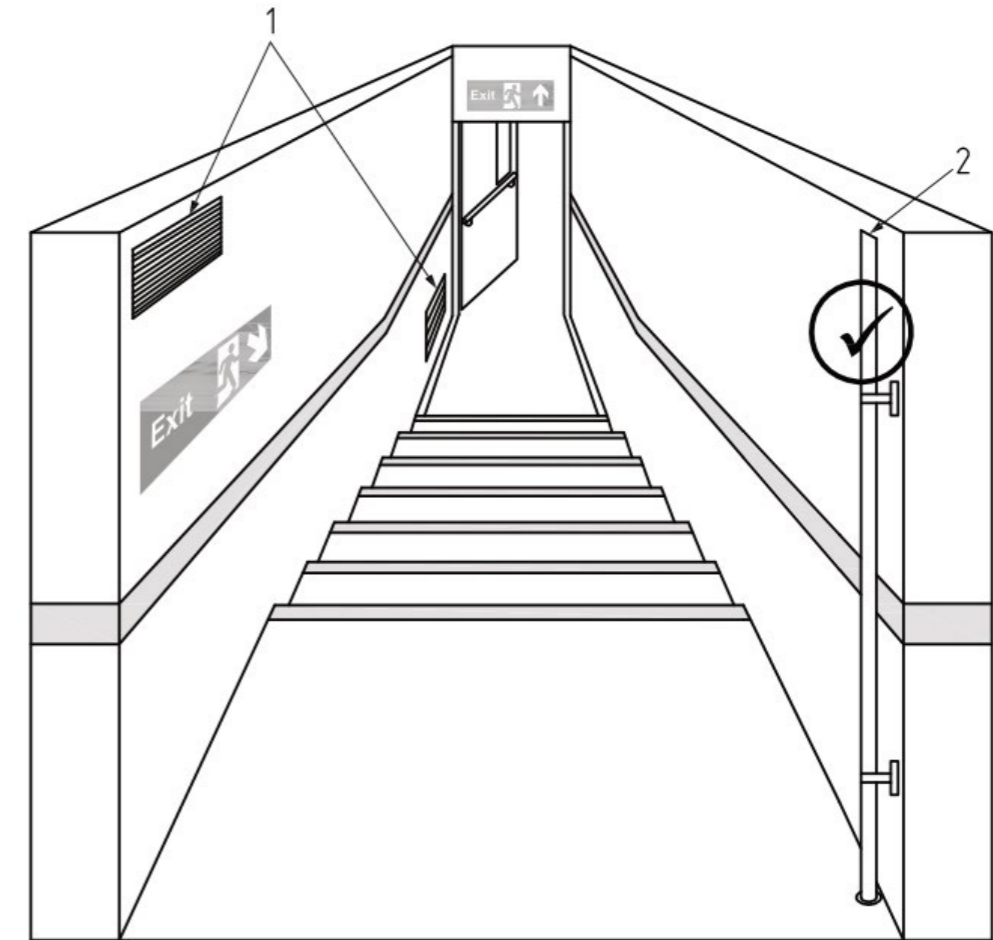

### Key

1. Vent direct to outside air.
2. Flexigas tubing of one continuous length

Where Flexigas is installed in a suspended ceiling above a protected area, and where this suspended ceiling does not form part of the required fire/acoustic performance of the compartment floor, the suspended ceiling void can be vented into the ‘normally occupied’ protected area via meeting the ventilation requirements of section 15.

Where such ventilation is not possible, Flexigas should be installed in a dedicated fire proof duct with at least the same fire-resisting construction as the protected area it is passing through.

## 28 - PIPE SIZING (INCLUDING EXAMPLE)

At the initial stages of design and planning a gas installation the designer/installer should verify that the installation pipes will be adequate for both immediate and probable future requirements, in particular where the pipe is to be buried or will be hard to access.

For domestic natural gas installations it is recommended practice to allow a maximum pressure loss of 1 mbar between the meter outlet and the appliance connection points. The pressure at the meter should be 21mbar (BS 6891). Low pressure 3rd family gas supplies should be regulated at 28mbar (butane) & 37mbar (propane) with a pressure drop not exceeding 2.5mbar (BS 5482).

Installers should also note that fittings can disrupt the discharge rates given in the sizing tables (which are for a straight horizontal run). Installers should add the following equivalent tubing lengths when estimating what size tube to use.

	90° bend	Tee (through flow)	Tee (diverted flow)	Coupling (fe/male/union)	Elbow
DN 15	0.3m	0.3m	0.9m	0.3m	0.9m
DN 22	0.3m	0.3m	0.9m	0.3m	0.9m
DN 28	0.3m	0.3m	0.9m	0.3m	0.9m
DN 32	0.3m	0.3m	1.0m	0.3m	1.0m
DN 40	0.3m	0.3m	1.0m	0.3m	1.0m
DN 50	0.3m	0.3m	1.5m	0.3m	1.0m

Installers should note that the discharge rates in the following tables are approximate and that a number of factors can affect the discharge rates in use (for example arcs in the tube not counted as 90° bends). Installers should make sure that the size of the pipe selected be of sufficient diameter to easily supply all the appliances on the installation when they are used at the maximum gas rate, plus allow for future appliances to be added that may have a higher gas rate (such as a larger gas boiler).

Figure 7 gives an example of a Flexigas domestic gas installation showing the lengths of pipes and the gas rates of the appliances.

When sizing pipes, it is essential that consideration is given to the permissible pressure loss in each section of the installation. For example, the pressure loss between A and H in Figure 7 should not exceed 1 mbar.

A to H is made up of four sections of pipe, A-B, B-D, D-F and F-H. Each section carries a different gas rate and needs to be sized separately.

If A to H is to have a pressure loss of not more than 1 mbar, then the pressure losses in each of the four sections should be approximately 0.25 mbar. So A-B, B-D, D-F and F-H should each be sized to give a pressure loss of approximately 0.25 mbar.

The table of discharges in a straight horizontal pipe given in Table 1 only allows for pressure losses of 1mbar. However, pressure loss is proportional to length, so if the pipe size selected in Table 1 is four times longer than required, the pressure loss on the actual length will be 0.25mbar.

## Working Example

Considering length D-F as given in Figure 7:

- D-F has a length of 1.5m and is to carry a gas rate of 1.5m<sup>3</sup>/h (for the cooker and the gas fire); it should have a pressure loss of 0.25mbar maximum.
- It also includes one tee fitting in the calculation (at point 4 – undiverted), and so 0.3m should be added to the equivalent length.
- A pressure loss of 0.25mbar in a length of 1.8m = 1 mbar in 7.2m (4 x 1.8m)
- In Table 1, look up the information for the closest unit to 7.2m. It is noted that 7m of DN22 will discharge approximately 4.2m<sup>3</sup>/h, and DN15 approximately 1.3 m<sup>3</sup>/h.

Thus the DN22 tubing gives a sufficient flow rate to carry the 1.5 m<sup>3</sup>/h of gas and allows a significant margin for major appliances to be added to the installation at a later date.

Figure 7 – Example Of A Pipe Sizing Calculation

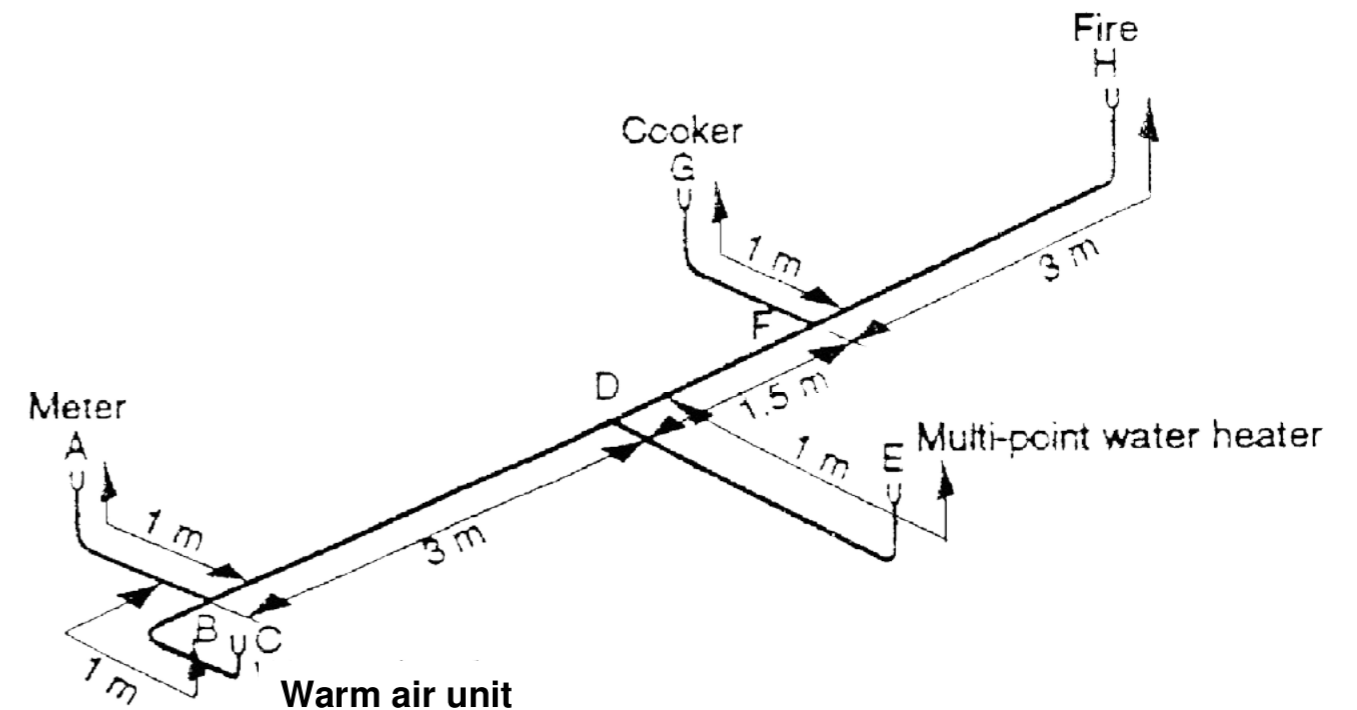

Appliance	Gas rate (typical) M <sup>3</sup> /h
Warm air unit	1.0
Multi-point water heater	2.5
Cooker	1.0
Gas fire	0.5
Central heating boiler	1.5
Combination boiler	2.5

29 – SIZING TABLES

TABLE 1

NATURAL GAS - Approximate discharge (m<sup>3</sup>/h) through a a straight horizontal run of Flexigas.  
(specific gravity = 0.6, pressure drop between ends = 1mbar)

	DN Size					
	15	22	28	32	40	50
1	4.2	10.3	19.5	35.0	59.0	120.0
2	2.8	7.4	13.4	24.5	41.0	84.3
3	2.2	6.4	11.0	20.3	34.0	68.8
4	1.9	5.4	9.2	17.6	29.5	59.3
5	1.6	4.7	8.5	15.8	26.7	53.0
6	1.5	4.4	7.7	14.3	23.8	48.6
7	1.3	4.2	7.1	13.2	22.0	44.4
8	1.2	3.9	6.7	12.3	20.5	41.3
9	1.1	3.7	6.3	11.7	18.9	39.2
10	1.0	3.5	6.0	11.2	17.9	37.0
12	0.9	3.2	5.5	10.3	16.4	33.6
15	0.8	2.9	4.9	9.2	14.6	30.1
20	0.7	2.5	4.3	7.9	12.6	25.8
25	0.5	2.3	3.8	7.1	11.3	23.0
30	0.5	2.1	3.5	6.5	10.3	20.8
40	0.5	1.8	3.0	5.5	8.9	18.0
50	0.4	1.6	2.7	5.0	8.0	16.0
60	0.4	1.5	2.5	4.6	7.3	14.6
70	0.3	1.4	2.3	4.3	6.7	13.4
80	0.3	1.3	2.1	4.0	6.3	12.7
90	0.3	1.2	2.0	3.8	5.9	12.0
100	0.3	1.1	1.9	3.6	5.6	11.0

Tubing Length (metres)

29 – SIZING TABLES

TABLE 2

PROPANE - Approximate discharge (m<sup>3</sup>/h) through a a straight horizontal run of Flexigas  
(specific gravity = 1.52, pressure drop between ends = 2.0mbar)

	DN Size					
	15	22	28	32	40	50
1	3.4	9.2	16.8	30.9	51.2	110.7
2	2.4	6.8	11.7	22.0	35.7	78.2
3	1.9	5.6	9.5	17.8	29.3	63.3
4	1.7	4.6	8.3	14.9	25.3	55.3
5	1.5	4.3	7.5	13.9	22.5	49.5
6	1.3	3.9	6.7	12.7	20.6	44.9
7	1.2	3.7	6.3	11.3	18.9	41.6
8	1.1	3.4	5.9	10.9	17.7	38.7
9	1.0	3.3	5.5	10.4	16.7	36.3
10	0.9	3.1	5.3	9.8	15.6	34.7
12	0.8	2.8	4.8	9.0	14.5	31.2
15	0.7	2.5	4.3	8.1	12.9	27.9
20	0.6	2.2	3.8	7.1	11.1	24.0
25	0.4	2.0	3.3	6.3	9.9	21.4
30	0.4	1.8	3.1	5.8	9.0	19.4
40	0.4	1.6	2.7	5.0	7.8	16.8
50	0.4	1.2	2.2	4.1	7.0	14.9
60	0.3	1.2	2.0	3.9	6.4	13.6
70	0.3	1.1	1.9	3.6	5.8	12.5
80	0.3	1.0	1.7	3.3	5.5	11.9
90	0.3	1.0	1.7	3.1	5.1	11.2
100	0.3	0.9	1.6	3.1	4.9	10.3

Tubing Length (metres)

29 – SIZING TABLES

TABLE 3

BUTANE - Approximate discharge (m3/h) through a a straight horizontal run of Flexigas (specific gravity = 2.07, pressure drop between ends = 2.0mbar)

	DN Size					
	15	22	28	32	40	50
1	2.9	8.2	14.0	26.0	43.8	94.8
2	2.1	5.8	10.0	18.5	30.6	67.0
3	1.7	4.8	8.1	15.2	25.1	54.2
4	1.4	4.1	7.0	13.1	21.6	47.4
5	1.2	3.7	4.3	11.6	19.3	42.4
6	1.1	3.4	5.8	10.8	17.6	38.5
7	1.1	3.2	5.4	10.2	16.2	35.6
8	0.9	3.0	5.0	9.5	15.1	33.2
9	0.8	2.8	4.7	8.9	14.3	31.1
10	0.8	2.6	4.5	8.6	13.4	29.8
12	0.7	2.4	4.1	7.7	12.4	26.7
15	0.6	2.2	3.7	7.0	11.0	23.9
20	0.5	1.9	3.2	6.0	9.5	20.5
25	0.4	1.7	2.9	5.4	8.5	18.3
30	0.4	1.6	2.6	4.9	7.7	16.6
40	0.4	1.4	2.3	4.3	6.7	14.4
50	0.3	1.2	1.9	3.5	6.0	12.8
60	0.3	1.0	1.7	3.3	5.5	11.7
70	0.2	1.0	1.6	3.0	5.0	10.7
80	0.2	0.9	1.5	2.9	4.7	10.2
90	0.2	0.8	1.4	2.7	4.4	9.6
100	0.2	0.8	1.4	2.6	4.2	9.0

Tubing Length (metres)

29 – SIZING TABLES

TABLE 4

NATURAL GAS - Approximate pressure drop (mbar per metre) through a straight horizontal 1m run of Flexigas (specific gravity = 0.6)

	DN15	DN22	DN28	DN32	DN40	DN50
0.1	0.001					
0.2	0.004	0.001				
0.25	0.005	0.001	0.001			
0.40	0.010	0.003	0.001	0.001		
0.50	0.015	0.003	0.001	0.001	0.001	
0.60	0.021	0.004	0.001	0.001	0.001	0.001
0.80	0.042	0.006	0.002	0.001	0.001	0.001
1.00	0.063	0.009	0.003	0.001	0.001	0.001
1.20	0.094	0.013	0.004	0.002	0.001	0.001
1.40	0.115	0.016	0.006	0.002	0.001	0.001
1.50	0.140	0.019	0.007	0.002	0.001	0.001
1.60	0.164	0.024	0.008	0.003	0.002	0.001
1.80	0.200	0.030	0.010	0.004	0.002	0.001
2.00	0.255	0.036	0.012	0.004	0.002	0.001
2.20	0.310	0.043	0.013	0.005	0.002	0.001
2.40	0.362	0.049	0.016	0.006	0.003	0.001
2.50	0.432	0.053	0.018	0.006	0.003	0.001
2.60	0.495	0.059	0.020	0.007	0.003	0.001
2.80	0.560	0.067	0.024	0.008	0.004	0.001
3.00	0.600	0.077	0.026	0.008	0.004	0.001
3.20	0.675	0.087	0.028	0.009	0.004	0.001
3.40	0.749	0.010	0.034	0.010	0.004	0.001
3.50	0.803	0.111	0.036	0.011	0.005	0.001
3.60	0.856	0.126	0.039	0.013	0.005	0.001
3.80	0.944	0.137	0.044	0.014	0.005	0.001
4.00	0.990	0.146	0.048	0.015	0.006	0.002
4.50		0.185	0.060	0.017	0.007	0.002
5.00		0.225	0.074	0.022	0.009	0.002
5.50		0.275	0.081	0.024	0.011	0.003
6.00		0.328	0.107	0.031	0.013	0.003
6.50		0.386	0.126	0.037	0.015	0.003
7.00		0.451	0.147	0.043	0.016	0.004
7.50		0.518	0.169	0.049	0.018	0.005
8.00		0.591	0.192	0.056	0.021	0.005
8.50		0.669	0.217	0.063	0.024	0.006
9.00		0.753	0.244	0.071	0.027	0.007
9.50		0.841	0.273	0.080	0.030	0.008
10.00		0.934	0.303	0.088	0.033	0.008
15.00			0.762	0.219	0.079	0.019
20.00			1.226	0.360	0.129	0.031
25.00				0.567	0.200	0.049
30.00				0.823	0.286	0.070
35.00				1.050	0.389	0.095
40.00					0.506	0.124
45.00					0.638	0.157
50.00					0.787	0.194
55.00					0.950	0.235
60.00					1.128	0.279
65.00						0.328
70.00						0.380
75.00						0.437
80.00						0.498
85.00						0.562
90.00						0.630
95.00						0.702
100.00						0.778

29 – SIZING TABLES

TABLE 5

PROPANE - Approximate pressure drop (mbar per metre) through a straight horizontal 1m run of Flexigas (specific gravity = 1.52)

	DN15	DN22	DN28	DN32	DN40	DN50
0.1	0.002					
0.2	0.010	0.002				
0.25	0.012	0.003	0.002			
0.40	0.026	0.008	0.003	0.002		
0.50	0.038	0.008	0.003	0.003	0.002	
0.60	0.053	0.010	0.003	0.003	0.003	0.001
0.80	0.106	0.015	0.005	0.003	0.003	0.002
1.00	0.158	0.023	0.008	0.003	0.003	0.003
1.20	0.238	0.033	0.010	0.005	0.003	0.003
1.40	0.290	0.040	0.015	0.005	0.003	0.003
1.50	0.353	0.050	0.018	0.005	0.003	0.003
1.60	0.415	0.063	0.020	0.008	0.005	0.003
1.80	0.506	0.078	0.025	0.010	0.005	0.003
2.00	0.643	0.093	0.030	0.010	0.005	0.003
2.20	0.782	0.110	0.033	0.013	0.005	0.003
2.40	0.914	0.125	0.043	0.015	0.008	0.003
2.50	1.092	0.138	0.048	0.015	0.008	0.003
2.60	1.250	0.153	0.053	0.018	0.008	0.003
2.80	1.414	0.173	0.063	0.020	0.010	0.003
3.00	1.517	0.198	0.068	0.020	0.010	0.003
3.20	1.704	0.225	0.073	0.023	0.010	0.003
3.40	1.891	0.250	0.088	0.025	0.010	0.003
3.50	2.050	0.285	0.093	0.028	0.013	0.003
3.60	2.208	0.325	0.100	0.033	0.013	0.003
3.80		0.353	0.113	0.035	0.013	0.003
4.00		0.375	0.123	0.038	0.015	0.005
4.50		0.478	0.155	0.045	0.018	0.005
5.00		0.580	0.190	0.058	0.023	0.005
5.50		0.708	0.210	0.063	0.028	0.008
6.00		0.845	0.275	0.080	0.033	0.008
6.50		0.995	0.325	0.095	0.038	0.008
7.00		1.163	0.380	0.110	0.043	0.010
7.50		1.335	0.435	0.128	0.048	0.013
8.00		1.492	0.495	0.145	0.055	0.013
8.50		1.656	0.560	0.163	0.063	0.015
9.00		1.824	0.630	0.183	0.070	0.018
9.50		1.994	0.703	0.205	0.078	0.020
10.00		2.215	0.780	0.228	0.085	0.020
15.00			1.826	0.565	0.000	0.000
20.00			2.967	0.928	0.333	0.080
25.00				1.463	0.515	0.125
30.00				1.950	0.738	0.180
35.00				2.668	1.003	0.245
40.00					1.253	0.320
45.00					1.579	0.405
50.00					1.898	0.500
55.00					2.252	0.605
60.00					2.675	0.720
65.00						0.845
70.00						0.980
75.00						1.125
80.00						1.283
85.00						1.448
90.00						1.623
95.00						1.774
100.00						1.925

29 – SIZING TABLES

TABLE 6

BUTANE - Approximate pressure drop (mbar per metre) through a straight horizontal 1m run of Flexigas (specific gravity = 2.07)

	DN15	DN22	DN28	DN32	DN40	DN50
0.1	0.003					
0.2	0.013	0.020				
0.25	0.017	0.003	0.003			
0.40	0.036	0.010	0.003	0.002		
0.50	0.053	0.010	0.003	0.003	0.002	
0.60	0.073	0.014	0.003	0.003	0.003	0.002
0.80	0.145	0.020	0.007	0.003	0.003	0.002
1.00	0.218	0.031	0.010	0.003	0.003	0.003
1.20	0.327	0.044	0.014	0.007	0.003	0.003
1.40	0.399	0.054	0.020	0.007	0.003	0.003
1.50	0.485	0.068	0.024	0.007	0.003	0.003
1.60	0.571	0.085	0.027	0.010	0.007	0.003
1.80	0.696	0.105	0.034	0.014	0.007	0.003
2.00	0.884	0.126	0.041	0.014	0.007	0.003
2.20	1.076	0.150	0.044	0.017	0.007	0.003
2.40	1.257	0.170	0.058	0.020	0.010	0.003
2.50	1.502	0.187	0.065	0.020	0.010	0.003
2.60	1.719	0.207	0.071	0.024	0.010	0.003
2.80	1.944	0.235	0.085	0.027	0.014	0.003
3.00	2.086	0.269	0.092	0.027	0.014	0.003
3.20	2.343	0.306	0.099	0.031	0.014	0.003
3.40	2.600	0.340	0.119	0.034	0.014	0.003
3.50	2.818	0.388	0.126	0.037	0.017	0.003
3.60		0.442	0.136	0.044	0.017	0.003
3.80		0.479	0.153	0.048	0.017	0.003
4.00		0.510	0.167	0.051	0.020	0.007
4.50		0.649	0.211	0.061	0.024	0.007
5.00		0.789	0.258	0.078	0.031	0.007
5.50		0.962	0.286	0.085	0.037	0.010
6.00		1.149	0.374	0.109	0.044	0.010
6.50		1.353	0.442	0.129	0.051	0.010
7.00		1.581	0.517	0.150	0.058	0.014
7.50		1.816	0.592	0.173	0.065	0.017
8.00		2.071	0.673	0.197	0.075	0.017
8.50		2.346	0.762	0.221	0.085	0.020
9.00		2.638	0.857	0.248	0.095	0.024
9.50		2.948	0.955	0.279	0.105	0.027
10.00		3.274	1.061	0.309	0.116	0.027
15.00			2.700	0.768	0.000	0.000
20.00				1.261	0.452	0.109
25.00				1.989	0.700	0.170
30.00				2.883	1.003	0.245
35.00					1.363	0.333
40.00					1.775	0.435
45.00					2.237	0.551
50.00					2.757	0.680
55.00						0.823
60.00						0.979
65.00						1.149
70.00						1.333
75.00						1.530
80.00						1.734
85.00						1.945
90.00						2.168
95.00						2.404
100.00						2.647

# Flexigas

☎ 01625 877 222

Unit 1 Armcon Business Park  
London South Road, Poynton, SK12 1LQ  
info@Flexigas.com or visit Flexigas.com