



Heating



Hot water



Renewables

For lasting comfort in every one of your customer's homes



Vaillant Comfort for your home



About Vaillant.....	3
Setting the standards since 1874.....	4
Why choose a Vaillant product?.....	5
Introducing Green iQ.....	6
ecoTEC & ecoFIT combi boilers.....	7
ecoTEC & ecoFIT system boilers.....	17
ecoTEC & ecoFIT open vent boilers.....	25
Technical data.....	29
Terminal clearances.....	40
Flue lengths.....	41
Flue solutions.....	42



Controls.....	45
MyVAILLANT Pro.....	54
Water filters.....	56
Domestic hot water cylinders.....	59
Training	63
Service and spares support.....	64
Guarantees.....	65
Order numbers.....	66

Please note the information contained in this guide is for the use of competent and qualified heating engineers in the UK. We always recommend attending a training course provided by Vaillant to ensure complete knowledge of the appliance and/or accessories you are installing. The Vaillant Group does not warrant the accuracy or completeness of any of the information provided in this brochure. Should you require any clarification or further information, please speak with your ASM or call our technical helpline. The Vaillant Group does not accept liability or responsibility resulting from the installer's failure to comply with the guides or otherwise. For more detailed information, please refer to the installation manual for each product you are using.

About Vaillant



The Vaillant Group

Vaillant is a brand within the Vaillant Group, a family-owned business that was founded by Johann Vaillant in his workshop in Remscheid, Germany in 1874.

In 1894, Johann patented a new closed-system gas-fired bathroom boiler. Johann's technical innovations continued and in 1924, he launched the world's first central heating boiler. Since these revolutionary inventions, the Vaillant brand has become synonymous with innovative heating solutions and continues to drive the evolution of heating technologies to this day.

The Vaillant Group is still family owned, and the family's consideration for safeguarding the environment for future generations runs through everything that Vaillant does. Vaillant is passionate about developing technologies that use the quality and efficiency of German engineering to create heating solutions that reduce carbon emissions and energy use to help to reduce our impact on the planet.

As the premium brand for sustainable and responsible heating and hot water solutions, it is Vaillant's mission to create a better climate, inside each home and the world around it.

There are now over 13,000 employees across 10 sites around the world who share this vision.

Setting the standards since 1874

Manufacturing at its finest

At Vaillant, we think ahead. By choosing our heating appliances, you choose the pioneering excellence of German design and UK manufacturing expertise that create reliable products specially designed for application in all markets.

As well as designing products to be as efficient as possible, we constantly review and update our manufacturing processes and environments.

Our UK factory continues to receive awards year after year in many categories. In addition to the many manufacturing awards we have received, we are especially proud to have been awarded the RoSPA Gold Award for world-class health and safety management systems for three consecutive years. We also have a gold Investors in People Award.

Vaillant has very high standards in manufacturing to ensure we make outstanding products. Our products meet ISO 9001, 18001, 14000 and many are Quiet Mark™ approved, which means that they use innovative and efficient technology that guarantees reduced noise levels.

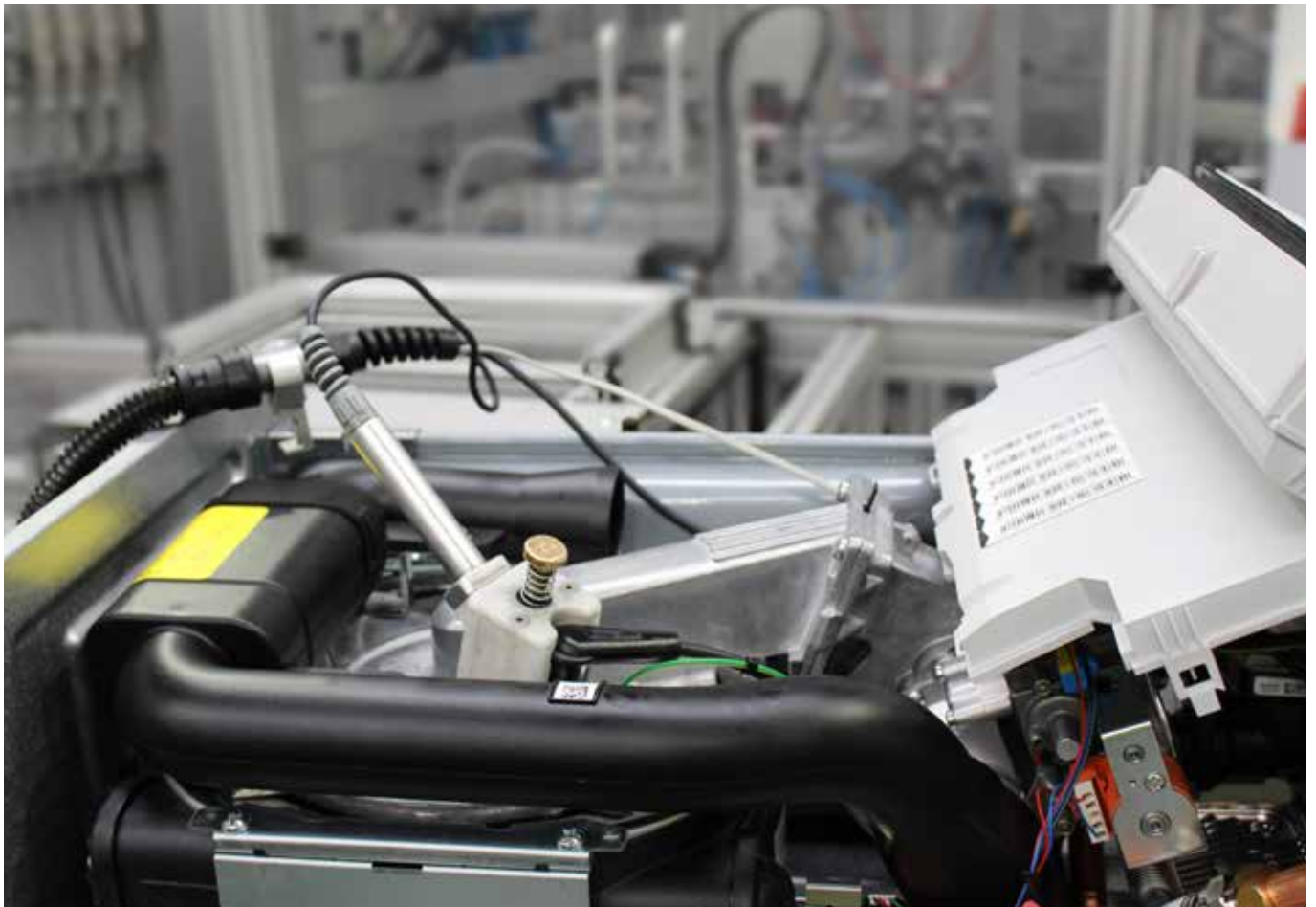



Why choose a Vaillant product?

Vaillant manufactures one of the largest ranges of boilers in the world and has its own renewables portfolio. From simple boilers for small dwellings to complex hybrid systems for commercial premises, Vaillant has a solution for every building's requirements.

Our core business is our award winning domestic boiler range. Vaillant produces wall-hung boilers with outputs from 12kW to 64kW and has open vent, system and combination models. With a wide range of flue options and a vast catalogue of accessories, including our own range of cylinders, we are confident we have a solution for every installation. We can even offer a unique combination storage boiler that has a 20 litres per minute flow rate.

Vaillant also manufactures boilers for commercial installations. Vaillant's commercial portfolio consists of large output wall-hung and floor-standing condensing boilers with compatible cascade rigs and accessories to cater for simple and large scale projects.

We always recommend our appliances are fitted with a Vaillant control. Vaillant has a wide range of controls, and each uses eBUS, our proprietary technology that ensures each element of a Vaillant system can communicate to ensure it is always working with ultimate efficiency.

All our controls come with load compensation as standard. Every Vaillant heating appliance can be matched with the perfect control to ensure compliance with Boiler Plus legislation.

Vaillant's controls range from simple analogue controls to smart app-controlled models that can be integrated with smart home systems and alert you to faults.

Our new range of senso controls have been designed to be incredibly easy to use and, with a stylish contemporary design, will look beautiful wherever they're sited.

Introducing Green iQ



A smart badge: Green iQ

The Vaillant brand demonstrates the philosophy of the Vaillant Group with the development of our flagship Green iQ range of boilers and heat pumps. We are proud that these products are incredibly efficient, have a low carbon footprint, are more than 85% recyclable and are engineered to be networked for the future.

The products in the Green iQ range combine our complete range of smart technologies and features to provide great performance.

The ecoTEC exclusive with Green iQ range of boilers intelligently manages energy consumption and output. This ensures the components of each boiler only work as hard as necessary to ensure optimum performance. Components will therefore last longer and be more reliable, reducing overall maintenance costs.

The ecoTEC exclusive with Green iQ range consists of two large output combi boilers with a host of features including extra condense technology. The system boiler in the range includes an integrated diverter valve, a first for Vaillant UK.



ecoTEC exclusive with Green iQ

Combi boilers



Overview

The ecoTEC exclusive is our first ever boiler range with the Green iQ technology. Combining our complete range of smart technologies and features, you can be sure you're fitting the very best when you fit an ecoTEC exclusive combi.

As well as providing great performance, the ecoTEC exclusive intelligently manages consumption and output to keep all its components running at peak performance, for longer, providing a low maintenance solution that you can rely on.

The combi range features 35kW and 43kW models, which can deliver much higher than average central heating outputs and hot water flow rates, making the ecoTEC exclusive a must have for larger properties. Additionally, the design of the ecoTEC exclusive combination boilers allows domestic hot water to be pre-heated using what would be wasted flue gas energy (full heat condense). This makes the boiler best in class for efficiency and Boiler Plus compliant out of the box.

All models in the ecoTEC exclusive range have patented high quality stainless steel heat exchangers that provide superior heat transfer and highly efficient performance.



Key features and benefits

- **Boiler Plus compliant out of the box**
Full heat condense
- **Green iQ mode**
Outstanding eco-credentials which optimise running cycles, resulting in even lower gas consumption
- **Highly recyclable**
ecoTEC exclusive is 85% recyclable at the end of its life
- **Premium quality components**
Includes brass diverter valve, ensuring highest reliability and performance
- **Wide modulation range of up to 1:10**
Adapts perfectly to all systems in every situation, ensuring lowest fuel bills for your customers
- **Extra condense stainless steel heat exchanger**
Takes overall combi boiler efficiency to the next level, and almost eliminates plume in DHW mode
- **Quiet Mark accreditation**
One of the quietest boilers on the market, designed for a peaceful home

- **10-year guarantee available**
A free five year guarantee comes as standard, rising to seven years out of the box when registered on Advance. A 10-year guarantee is available when boilers are installed with a Boiler Protection Kit and registered on Advance
- **Easy installation and maintenance**
Accessible layout allows all components to be replaced from the boiler front. Removable side panels for even more access
- **Step by step full text installation wizard**
For quicker, 'first time right' set-up and installation
- **High power, 43kW output model available**
Delivers Vaillant's highest ever flow rate
- **All-gas system**
As a self-adaptive system, it automatically adjusts to all types of gas including LPG for off-gas areas
- **Compatible with Vaillant's range of intelligent controls**
Delivers an easy to use and energy efficient system, saving money on energy bills
- **Flame lift detection system**
For enabling more efficient and quieter combustion
- **Self diagnostic combustion intelligence**
Includes flame lift detection for more efficient and quieter combustion

Dimensions:

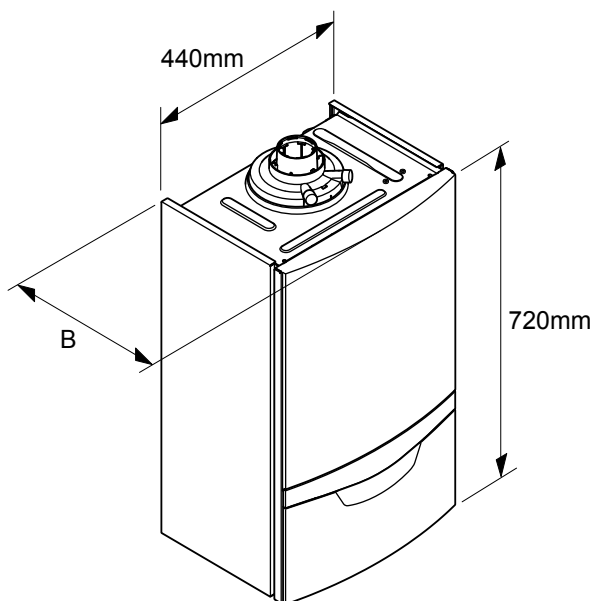

Installation depth	Dimension B
ecoTEC exclusive 835	406mm
ecoTEC exclusive 843	474mm

Clearances:

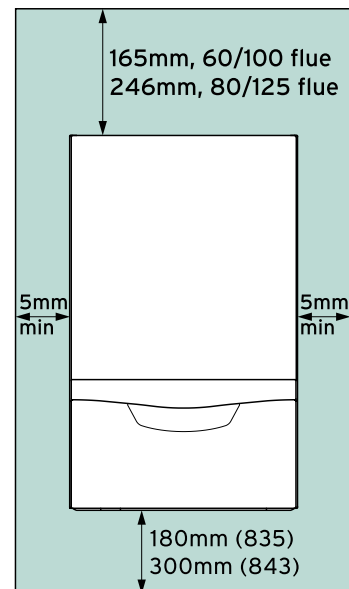

Note: A 500mm front clearance is recommended to allow easy access during inspection and maintenance

ecoTEC plus

Combi boilers



Overview

The ecoTEC plus range of combination boilers is extremely reliable. All models have the quality of components and manufacturing that Vaillant is known for, providing outstanding performance and build quality.

With continuous modulation and real combustion control by a multi-sensor system, Vaillant's ecoTEC plus boilers achieve high efficiency at the lowest emissions.

The ecoTEC plus is available in a range of power outputs to meet the heating requirements of varying house sizes. Each one is ultra-quiet, a feature recognised by the Noise Abatement Society, which has awarded many of the ecoTEC plus range the Quiet Mark for its innovative design, specifically created to ensure a peaceful home for your customers.



Key features and benefits

- Boiler Plus compliant with Vaillant controls**
 Install with sensoHOME, sensoCOMFORT, vSMART, or VRC 700 for a smart weather compensated system
- Premium quality components**
 Includes brass diverter valve, ensuring highest reliability and performance
- Wide modulation range of up to 1:6**
 Adapts perfectly to all systems in every situation, ensuring lowest fuel bills for your customers
- Patented stainless steel heat exchanger**
 Provides superior heat transfer and highly efficient performance
- 10-year guarantee available**
 A free five year guarantee comes as standard, rising to seven years out of the box when registered on Advance. A 10-year guarantee is available when boilers are installed with a Boiler Protection Kit and registered on Advance
- Easy installation and maintenance**
 Accessible layout allows all components to be replaced from the boiler front. Removable side panels for even more access
- Step by step full text installation wizard**
 For error free, quick and simple set-up and installation
- 38kW output model available**
 Delivers a range of flow rates to suit all properties

- Dedicated models available for LPG**
 A perfect solution for off-gas areas
- Compatible with Vaillant's range of intelligent controls**
 Delivers an easy to use and energy efficient system, saving money on energy bills
- Electronic gas and air modulation system**
 Allows precise self setting gas combustion to improve performance and lower emissions
- Flame lift detection system**
 Enables more efficient and quieter combustion
- Push fit flue system with industry leading flue lengths**
 80/125 flue adaptor and system for even longer lengths and installation flexibility
- Large backlit plain text display**
 Delivers clear visibility in poor light conditions and easy reading of current boiler operation
- Features Vaillant's exclusive AquaComfort system**
 Provides quick delivery of hot water at a constant temperature, which reduces unnecessary water wastage
- Integrated filling loop**
 Makes installation even quicker
- Built-in two-stage frost protection**
 Ensures optimal performance all year round

Dimensions:

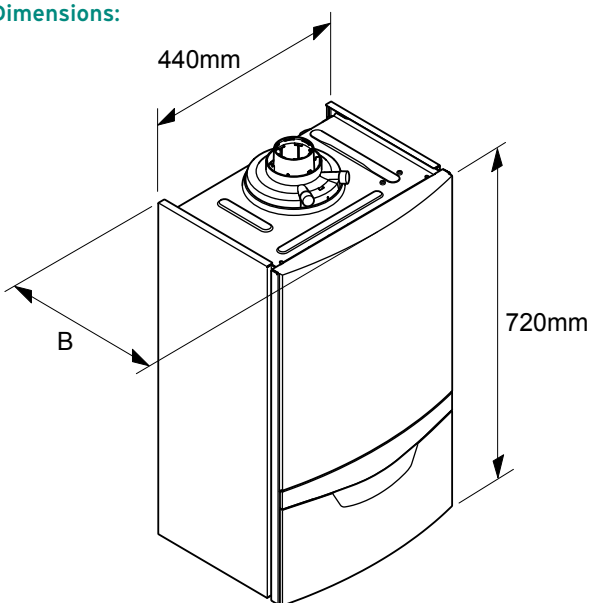

Installation depth	Dimension B
ecoTEC plus 825 ecoTEC plus 832	338mm
ecoTEC plus 835	372mm
ecoTEC plus 838	406mm

Clearances:

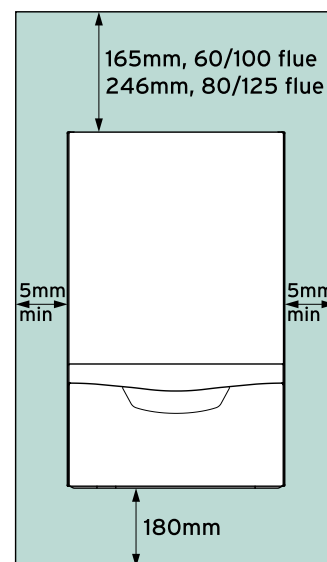

Note: A 500mm front clearance is recommended to allow easy access during inspection and maintenance

ecoTEC plus

Storage combi boilers



Overview

The ecoTEC plus storage combi is a 38kW high efficiency storage combination boiler which has been designed especially for larger homes that have a higher hot water demand, but not enough to warrant the installation of a cylinder.

The ecoTEC plus storage combi features an innovative integrated hot water storage device at the back of the boiler. This special feature means the product is capable of delivering up to 20 litres of hot water per minute.

The ecoTEC plus storage combi has a stainless steel heat exchanger alongside the premium components you expect from a Vaillant appliance.



Key features and benefits

- **Boiler Plus compliant with Vaillant controls**
Install with sensoHOME, sensoCOMFORT, vSMART, or VRC 700 for a smart weather compensated system
- **Premium quality components**
Includes brass diverter valve, ensuring highest reliability and performance
- **Wide modulation range of up to 1:6**
Adapts perfectly to all systems in every situation, ensuring lowest fuel bills for your customers
- **Patented stainless steel heat exchanger**
Provides superior heat transfer and highly efficient performance
- **10-year guarantee available**
A free five year guarantee comes as standard, rising to seven years out of the box when registered on Advance. A 10-year guarantee is available when boilers are installed with a Boiler Protection Kit and registered on Advance
- **Easy installation and maintenance**
Accessible layout allows all main boiler components to be replaced from the boiler front
- **Step-by-step full text installation wizard**
For error free, quick and simple set-up and installation

- **Innovative 38kW solution for large homes**
Integrated hot water storage delivers best in class flow rates to suit a range of properties
- **Compatible with Vaillant's range of intelligent controls**
Delivers an easy to use and energy efficient system, saving money on energy bills
- **Electronic gas and air modulation system**
Allows precise self setting gas combustion to improve performance and lower emissions
- **Flame lift detection system**
Enables more efficient and quieter combustion
- **Push fit flue system with industry leading flue lengths**
80/125 flue adaptor and system for even longer flue lengths and installation flexibility
- **Large backlit plain text display**
Delivers clear visibility in poor light conditions and easy reading of current boiler operation
- **Integrated filling loop**
Makes installation even quicker
- **Built-in two-stage frost protection**
Ensures optimal performance all year round

Dimensions:

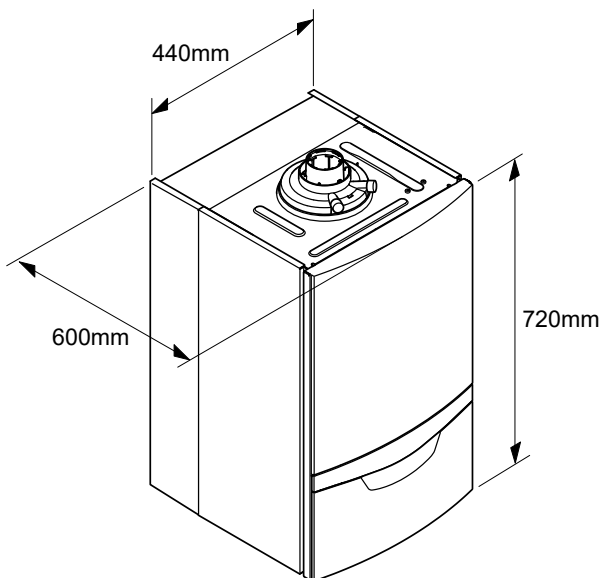

Clearances:

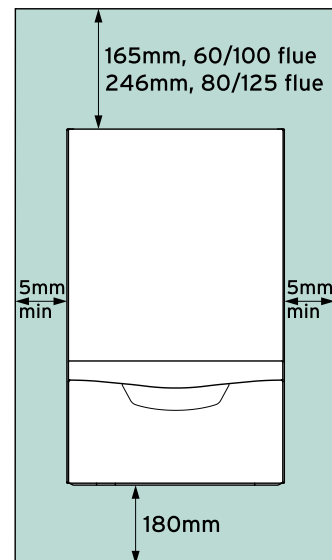

Note: A 500mm front clearance is recommended to allow easy access during inspection and maintenance

ecoTEC pro

Combi boilers



Overview

The ecoTEC pro range of combination boilers combines the built-in quality, reliability, and performance you'd expect from Vaillant, with a simple design and approach.

The range features 24, 28, and 30kW models, making this boiler perfect for homes with smaller heating and hot water requirements.

With a small footprint and compact dimensions, the ecoTEC pro combination boilers offer versatile siting options. They're also really easy to install and service, with a push-fit flue system and removable side panels to make life that much easier.

The ecoTEC pro has an LPG version of this boiler, so it's perfect for off-gas areas. It's also compatible with our aroTHERM heat pumps, offering even more choice for off-grid properties.



Key features and benefits

- **Boiler Plus compliant with Vaillant controls**
Install with sensoHOME, sensoCOMFORT, vSMART, or VRC 700 for a smart weather compensated system
- **Quality components**
Quality and reliability you would expect from Vaillant
- **Wide modulation range of up to 1:5**
Adapts perfectly to most systems in domestic applications, resulting in lower fuel bills for your customers
- **Patented stainless steel heat exchanger**
Provides superior heat transfer and highly efficient performance
- **Seven year guarantee available**
A free two year guarantee comes as standard, rising to seven years out of the box when registered on Advance
- **Easy installation and maintenance**
Accessible layout allows all components to be replaced from the boiler front. Removable side panels for even more access
- **Step by step installation wizard**
For error free, quick and simple set-up and installation
- **30kW output model available**
Delivers a range of flow rates to suit all properties

- **Dedicated model available for LPG**
A great solution for off-gas areas
- **Compatible with Vaillant's range of intelligent controls**
Delivers an easy to use and energy efficient system, saving money on energy bills
- **Electronic gas and air modulation system**
Allows precise self setting gas combustion to improve performance and lower emissions
- **Flame lift detection system**
Enables more efficient and quieter combustion
- **Push fit flue system with industry leading flue lengths**
80/125 flue adaptor and system for even greater flue lengths
- **Plain text display**
High quality text for clear visibility and understanding of current boiler operation
- **Features Vaillant's exclusive AquaComfort system**
Provides quick delivery of hot water at a constant temperature, preventing unnecessary water wastage
- **ErP A rated boiler range**
Delivers highest efficiency and lowest running costs
- **Built-in two-stage frost protection**
Ensures optimal performance all year round

Dimensions:

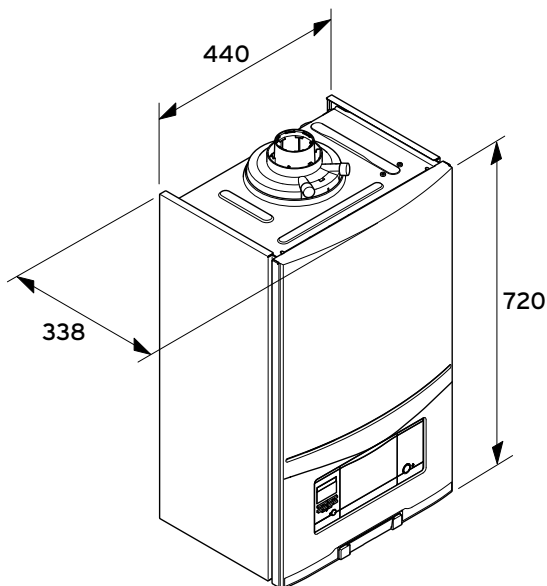

Clearances:

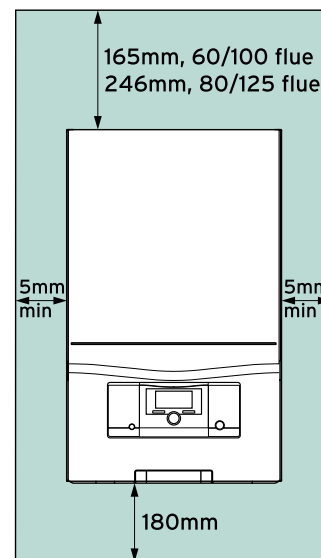

Note: A 500mm front clearance is recommended to allow easy access during inspection and maintenance

ecoFIT pure

Combi boilers



Overview

Ultra-quiet operation, a small footprint and total flexibility of siting (with top and rear flue options) mean that the ecoFIT pure range fits in with your customers' needs. It's the perfect solution for fitting inside a standard kitchen cupboard unit.

The automatic purging assistant and high specification, automotive grade, aluminium heat exchanger makes for a lightweight installation.

With high quality, highly efficient components, complete availability of spare parts and an accessible layout, the ecoFIT pure is easy to maintain and service.



Key features and benefits

- **Compact, cupboard fit solution**

A smaller footprint and cupboard fit dimensions offers flexibility of siting

- **Four-sided cooling and water agitation of the heat exchanger**

Reduces the stress on the heat exchanger for longer life reliability and reduced maintenance costs

- **Boiler Plus compliant with Vaillant controls**

Install with VRT 350 or VRT 50 + timeSWITCH 150 for a load compensated system

- **Premium quality components**

For great reliability and performance

- **Wide modulation range of up to 1:5**

Adapts perfectly to most systems in domestic applications, resulting in lower fuel bills for your customers

- **High-specification aluminium heat exchanger**

Designed for longer life, easier maintenance, and smaller energy bills

- **Seven year guarantee available**

A free two year guarantee comes as standard, rising to seven years out of the box when registered on Advance. It's also eligible for a 10-year guarantee when fitted with our Boiler Protection Kit

- **Easy installation and maintenance**

Accessible layout allows all components to be replaced from the boiler front. Removable side panels for even more access

- **35kW output model available**

Delivers a range of flow rates to suit all properties

- **Compatible with Vaillant's range of intelligent controls**

Delivers an easy to use and energy efficient system, saving money on energy bills

- **Pneumatic gas and air modulation system**

For precise self setting gas combustion to improve performance and lower emissions

- **Top and rear flue options**

Flue options and cupboard fit dimensions offer flexibility of siting

- **Push fit flue system with industry leading flue lengths**

80/125 vertical flue lengths of up to 25m for greater installation flexibility

- **Bright clear LED display**

Delivers clear visibility in poor light conditions and easy reading of current boiler operation

- **ErP A rated boiler range**

Delivers highest efficiency and lowest running costs

- **Integrated filling loop**

Makes installation even quicker

Dimensions:

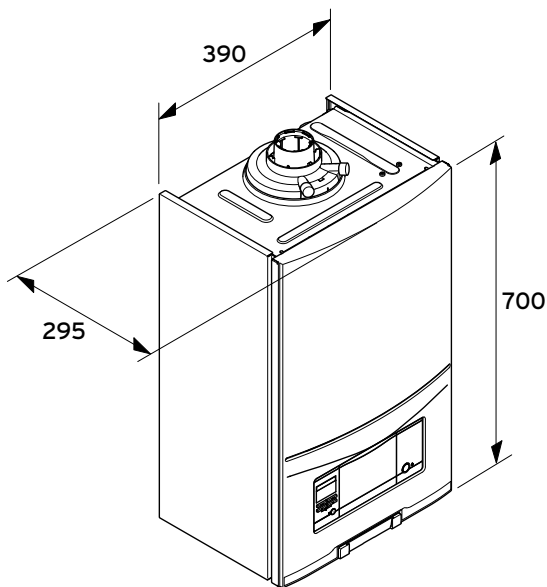

Clearances:

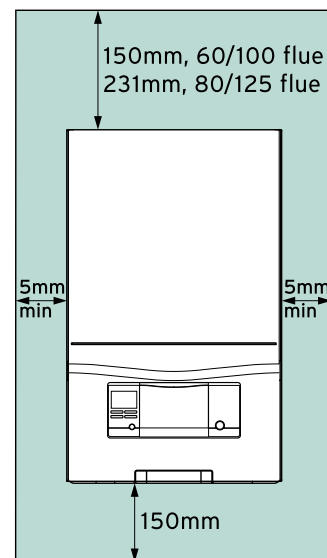

Note: A 500mm front clearance is recommended to allow easy access during inspection and maintenance

ecoTEC exclusive with Green iQ

System boilers



Overview

The ecoTEC exclusive is our first ever boiler with Green iQ technology. Combining our complete range of smart technologies and features, you can be sure you're fitting the very best when you fit new the new 27kW ecoTEC exclusive with Green iQ system boiler.

As well as providing great performance, the ecoTEC exclusive intelligently manages consumption and output to keep all its components running at peak performance, for longer, providing a low maintenance solution that you can rely on.

The ecoTEC exclusive system boiler includes an integrated diverter valve for the first time in UK Vaillant history.



Key features and benefits

- **Green iQ Mode**
Outstanding eco-credentials which optimise running cycles, resulting in even lower gas consumption
- **Highly recyclable**
ecoTEC exclusive is 85% recyclable at the end of its life
- **Premium quality components**
Ensures highest reliability and performance
- **Wide modulation range of up to 1:10**
Adapts perfectly to all systems in every situation, resulting in lower fuel bills for your customers
- **Patented stainless steel heat exchanger**
Provides superior heat transfer and highly efficient performance
- **10-year guarantee available**
A free five year guarantee comes as standard, rising to seven years out of the box when registered on Advance. A 10-year guarantee is available when boilers are installed with a Boiler Protection Kit and registered on Advance

- **Easy installation and maintenance**
Accessible layout allows all components to be replaced from the boiler front. Removable side panels for even more access
- **Step-by-step full text installation wizard**
For error free, quick and simple set-up and installation
- **All-gas system**
Always reaches optimal combustion with lowest emissions. As a self-adaptive system, it automatically adjusts to all types of gas
- **Compatible with Vaillant's range of intelligent controls**
Delivers an easy to use and energy efficient system, saving money on energy bills
- **Integrated three-way valve**
Four-pipe system with load compensation in DHW and CH modes. No more complex wiring systems, junction boxes or external zone valves
- **Push fit flue system with industry leading flue lengths**
80/125 vertical flue lengths for even greater flue lengths

Dimensions:

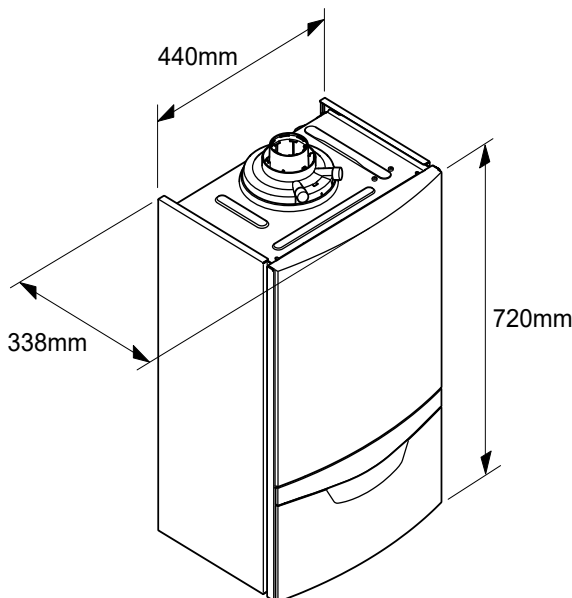

Clearances:

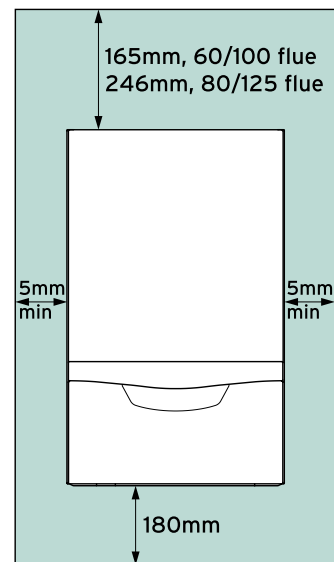

Note: A 500mm front clearance is recommended to allow easy access during inspection and maintenance

ecoTEC plus

System boilers



Overview

The ecoTEC plus range of boilers is extremely reliable. All models have the quality of components and manufacturing that Vaillant is known for, providing outstanding performance and build quality.

With continuous modulation and real combustion control by a multi-sensor system, Vaillant's ecoTEC plus boilers achieve high efficiency at the lowest emissions.

The ecoTEC plus system boiler is available in a range of power outputs to meet the heating requirements of varying house sizes. With outputs of 12, 15, 18, 24, 30 and 37kW, there's a perfect size for the requirements of most domestic buildings.

Whichever output you choose, you can be assured it is ultra-quiet, a feature recognised by the Noise Abatement Society, which has awarded the ecoTEC plus range the Quiet Mark for its innovative design, specifically created to ensure a peaceful home for your customers.



Key features and benefits

- **Boiler Plus compliant with time and temperature controls**

Install with VRT 15, timeSWITCH 160 and VR 66 wiring centre for the easiest way to meet Boiler Plus

- **Premium quality components**

For highest reliability and performance

- **Wide modulation range of up to 1:6**

Adapts perfectly to all systems in every situation, resulting in lower fuel bills for your customers

- **Patented stainless steel heat exchanger**

Provides superior heat transfer and highly efficient performance

- **10-year guarantee available**

A free five year guarantee comes as standard, rising to seven years out of the box when registered on Advance. A 10-year guarantee is available when boilers are installed with a Boiler Protection Kit and registered on Advance

- **Easy installation and maintenance**

Accessible layout allows all components to be replaced from the boiler front. Removable side panels for even more access

- **Step by step full text installation wizard**

For error free, quick and simple set-up and installation

- **Dedicated models available for LPG**

A great solution for off-gas areas

- **Electronic gas and air modulation system**

Allows precise self setting gas combustion to improve performance and lower emissions

- **Flame lift detection system**

Enables more efficient and quieter combustion

- **Push fit flue system with industry leading flue lengths**

80/125 vertical flue lengths of up to 41m for greater installation flexibility

- **Large backlit plain text display**

Delivers clear visibility in poor light conditions and easy reading of current boiler operation

- **Compatible with heat pump hybrid system**

Can be fitted with an aroTHERM heat pump to create a hybrid system

- **Precise German engineering and design**

Quality manufacturing from award winning factory in Derbyshire

- **Recognisable Vaillant fault codes**

Making it easy to diagnose faults

Dimensions:

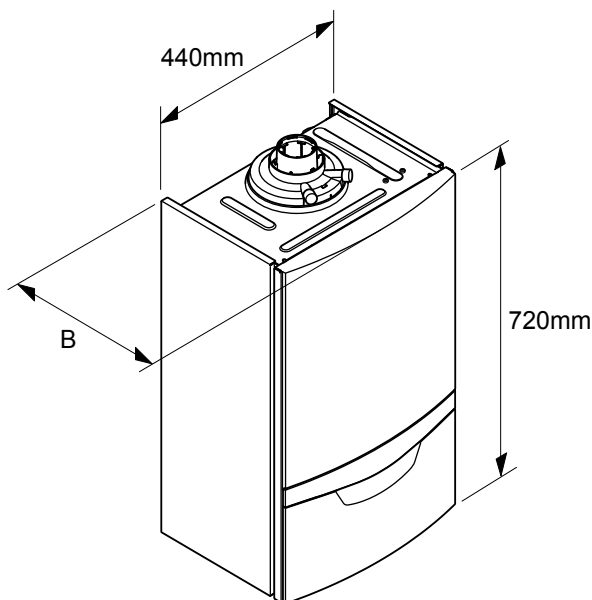

Installation depth	Dimension B
ecoTEC plus 612 ecoTEC plus 615 ecoTEC plus 618 ecoTEC plus 624	338mm
ecoTEC plus 630	372mm
ecoTEC plus 637	406mm

Clearances:

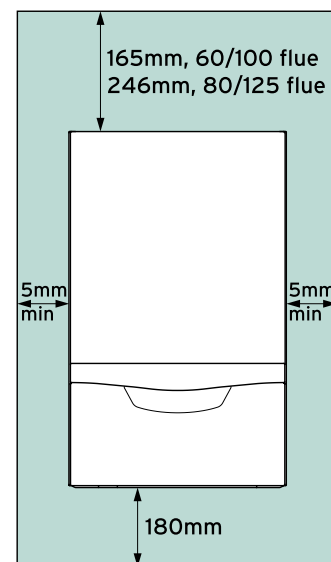

Note: A 500mm front clearance is recommended to allow easy access during inspection and maintenance

ecoTEC plus

Large output system boilers



Overview

The ecoTEC plus 48 and 64kW boilers are compact in size and extremely lightweight. The front and side panels can be removed, allowing for much easier access in tight and restrictive spaces.

The internal ducted rain collector prevents rain ingress from the flue system depositing in the boiler casing, and the new gunmetal air separation device prevents unwanted vented emissions within the case, both of which help to protect the electronics inside the boiler. ecoTEC plus 48 and 64kW can be converted to LPG to cater for projects that are unable to use a natural gas supply. These boilers can be cascaded for projects that require outputs above 70kW.



Key features and benefits

- **Compact dimensions**
For easy siting in tight spaces
- **ErP A+ rated**
When installed with a class VI control
- **Low NOx burner system**
Levels as low as 29mg/kWh to minimise environmental impact
- **Premium quality components**
Ensures highest reliability and performance
- **Wide modulation range of up to 1:5**
Adapts perfectly to all systems in every situation, resulting in lower fuel bills for your customers
- **Patented stainless steel heat exchanger**
Provides superior heat transfer and highly efficient performance
- **Easy installation and maintenance**
Accessible layout allows all components to be replaced from the boiler front. Removable side panels for even more access
- **Step by step full text installation wizard**
For error free, quick and simple set-up and installation
- **Compatible with LPG**
A great solution for off-gas areas

- **Electronic gas and air modulation system**
Allows for precise self setting gas combustion to improve performance and lower emissions
- **A range of push fit flue systems available**
80/125 vertical, horizontal and facade flue accessories for greater installation flexibility
- **Large backlit plain text display**
Delivers clear visibility in poor light conditions and easy reading of current boiler operation
- **Built-in two-stage frost protection**
Ensures optimal performance all year round
- **Compatible with heat pump hybrid system**
Can be fitted with an aroTHERM heat pump to create a hybrid system
- **Recognisable Vaillant fault codes**
For easy diagnosis
- **Out of the box guarantees**
Five-year guarantee as standard, for added peace of mind
- **Ability to cascade**
For flexible siting and increased outputs of up to 256kW. Cascaded larger output boilers can operate up to 3bar

Dimensions:

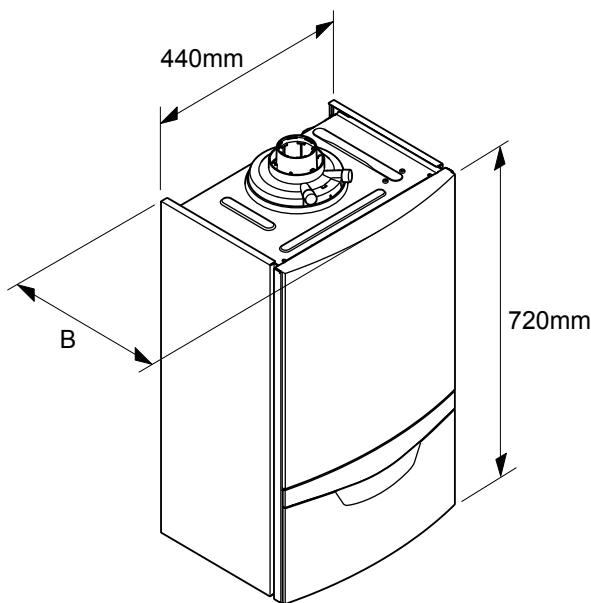

Installation depth	Dimension B
ecoTEC plus 48	405mm
ecoTEC plus 64	473mm

Clearances:

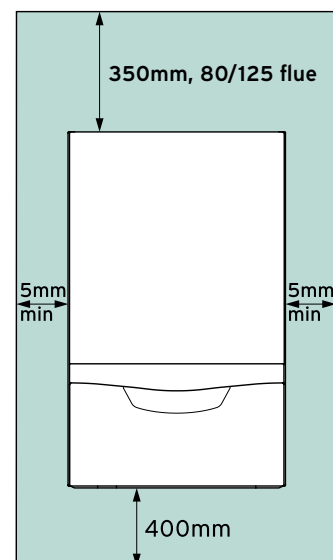

Note: A 500mm front clearance is recommended to allow easy access during inspection and maintenance

Note: Our larger output boilers must be fitted with Vaillant's proprietary low loss header (WH40/2 article number 0020248932) designed to fit directly under the boiler

ecoFIT pure

System boilers



Overview

ecoFIT pure system boilers offer great features and a wide range of outputs, with 12, 15, 18, 25 and 30kW outputs. They're all ultra-quiet in operation, have a small footprint and flexible siting options (including a choice of top or rear flues).

The automatic purging assistance and high specification, aluminium heat exchanger make for a lightweight installation.

With high quality, highly efficient components, complete availability of spare parts and an accessible layout, the ecoFIT pure easy to maintain and service.



Key features and benefits

- **Premium quality components**

Ensuring highest reliability and performance

- **Boiler Plus compliant with time and temperature controls**

Install with VRT 15, timeSWITCH 160 and VR 66 wiring centre for the easiest way to meet Boiler Plus

- **Wide modulation range of up to 1:5**

Adapts perfectly to all systems in every situation, resulting in lower fuel bills for your customers

- **Patented high-specification aluminium heat exchanger**

Designed for longer life, easier maintenance and smaller energy bills

- **Out of the box guarantees**

Two year free guarantee can be extended to seven years when installs are registered on Advance. It's also eligible for a 10-year guarantee when fitted with our Boiler Protection Kit.

- **Easy installation and maintenance**

Accessible layout allows all components to be replaced from the boiler front. Removable side panels for even more access

- **Pneumatic gas and air modulation system**

Allows precise self setting gas combustion to improve performance and lower emissions

- **Top and rear flue options**

A smaller footprint and cupboard fit dimensions offer flexibility of siting

- **Push fit flue system with industry leading flue lengths**

80/125 vertical flue lengths of up to 25m for greater installation flexibility

- **Bright clear LED display**

Delivers clear visibility in poor light conditions and easy reading of current boiler operation

- **ErP A rated boiler**

Delivers highest efficiency and lowest running costs

- **Built-in two-stage frost protection**

Ensures optimal performance all year round

- **Patented four-sided cooling and water agitation of the heat exchanger**

Reduces stress on the heat exchanger for longer life reliability and reduced maintenance costs

- **Precise German engineering and design**

Quality manufacturing from award winning factory in Derbyshire

- **Recognisable Vaillant fault codes**

For easy fault diagnosis

Dimensions:

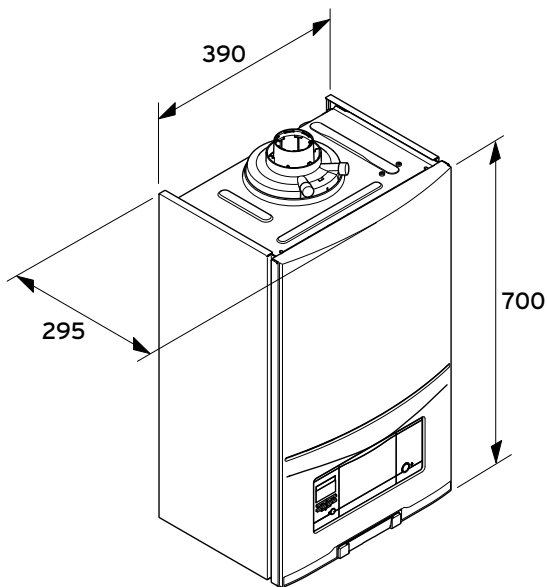

Clearances:

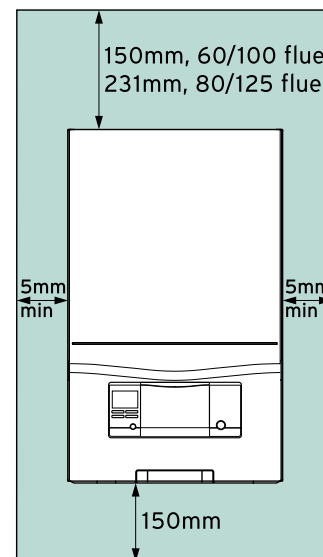

Note: A 600mm front clearance is recommended to allow easy access during inspection and maintenance

ecoTEC plus

Open vent boilers



Overview

The ecoTEC plus range of open vent boilers is extremely reliable. All models have the quality of components and manufacturing that Vaillant is known for, providing outstanding performance and build quality.

With continuous modulation and real combustion control by a multi-sensor system, Vaillant's ecoTEC plus boilers achieve high efficiency at the lowest emissions. These boilers have an aluminium heat exchanger with wide waterways: an ideal choice for older properties.

They're available with outputs of 12, 15, 18, 24, 30 and 35kW, so there's an ecoTEC plus open vent boiler that can meet the heating requirements of varying house sizes.

Each one is ultra-quiet, a feature recognised by the Noise Abatement Society, which has awarded the ecoTEC plus range the Quiet Mark for its innovative design, specifically created to ensure a peaceful home for your customers.

Key features and benefits

- **Wide modulation range of up to 1:5**

Adapts perfectly to all systems in every situation, resulting in lower fuel bills for your customers

- **Boiler Plus compliant with time and temperature controls**

Install with VRT 15, timeSWITCH 160 and VR 66 wiring centre for the easiest way to meet Boiler Plus

- **High-specification aluminium heat exchanger**

Designed for longer life, easier maintenance and smaller energy bills

- **10 year guarantee available**

A free five year guarantee comes as standard, rising to seven years out of the box when registered on Advance. A 10 year guarantee is available when boilers are installed with a Boiler Protection Kit and registered on Advance

- **Easy installation and maintenance**

Accessible layout allows all components to be replaced from the boiler front. Removable side panels for even more access

- **Compact, cupboard fit solution**

Smaller boiler footprint offers flexibility of siting, including a cupboard fit

- **Dedicated model available for LPG**

Great solution for off-gas areas

- **Electronic gas and air modulation system**

Allows for precise self setting gas combustion to improve performance and lower emissions

- **Top and rear flue options**

Flue options and cupboard fit dimensions offer flexibility of siting

- **Push fit flue system with industry leading flue lengths**

80/125 vertical flue lengths of up to 25m for greater installation flexibility

- **Bright clear LED display**

Delivers clear visibility in poor light conditions and easy reading of current boiler operation

- **ErP A rated boiler**

Delivers highest efficiency and lowest running costs

- **Compatible with heat pump hybrid system**

Can be fitted with an aroTHERM heat pump to create a hybrid system

Dimensions:

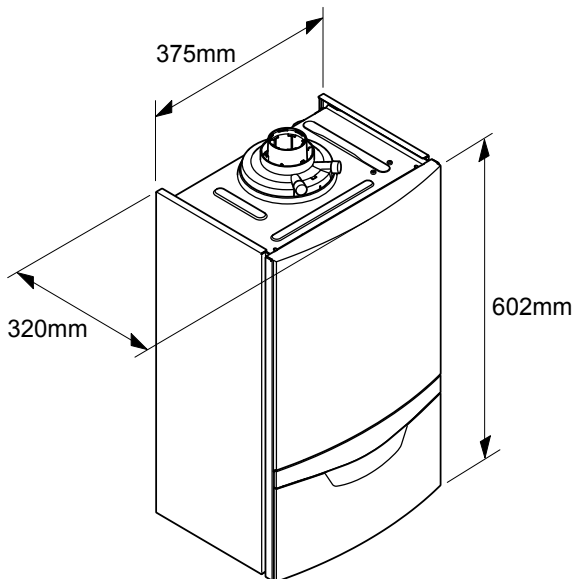

Clearances:

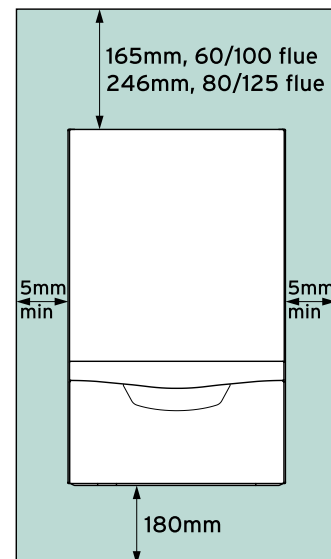

Note: A 600mm front clearance is recommended to allow easy access during inspection and maintenance

ecoFIT pure

Open vent boilers



Overview

The ecoFIT pure range of open vent boilers has a wide range of outputs to choose from, with 12, 15, 18, 25, 30 and 35kW models available. With ultra-quiet operation, a small footprint and flexible siting options (including a choice of top or rear flues), the ecoFIT pure range has a model to fit your customers' needs.

The automatic purging assistance and high specification, aluminium heat exchanger make for a lightweight installation.

High quality and high efficiency, together with the complete availability of spare parts and the easy accessibility of the unit layout means the ecoFIT pure is easy to maintain too.

Key features and benefits

- **Premium quality components**
For great reliability and performance
- **Wide modulation range of up to 1:5**
Adapts perfectly to all systems in every situation, ensuring lowest fuel bills for your customers
- **Boiler Plus compliant with time and temperature controls**
Install with VRT 15, timeSWITCH 160 and VR 66 wiring centre for the easiest way to meet Boiler Plus
- **High-specification aluminium heat exchanger**
Designed for longer life, easier maintenance, and lower energy bills
- **Seven year guarantee available**
A free two year guarantee comes as standard and is extended to seven years when registered on Advance
- **Easy installation and maintenance**
Accessible layout allows all components to be replaced from the boiler front. Removable side panels for even more access
- **Compact, cupboard fit solution**
Flexible siting options due to small footprint and cupboard fit dimensions

- **Pneumatic gas and air modulation system**
Allows precise self setting gas combustion to improve performance and lower emissions
- **Top and rear flue options**
Flexible flue options to suit various properties
- **Push fit flue system with industry leading flue lengths**
80/125 vertical flue lengths of up to 25m for greater installation flexibility
- **Bright clear LED display**
Delivers clear visibility in poor light conditions and easy reading of current boiler operation
- **ErP A rated boiler**
Delivers highest efficiency and lowest running costs
- **Built-in two-stage frost protection**
Ensures optimal performance all year round
- **Patented four-sided cooling and water agitation of the heat exchanger**
Reduces stress on the heat exchanger to increase longevity and reliability while reducing maintenance costs
- **Precise German engineering and design**
Quality manufacturing from Vaillant's award winning factory in Derbyshire
- **Recognisable Vaillant fault codes**
For easy fault diagnosis

Dimensions:

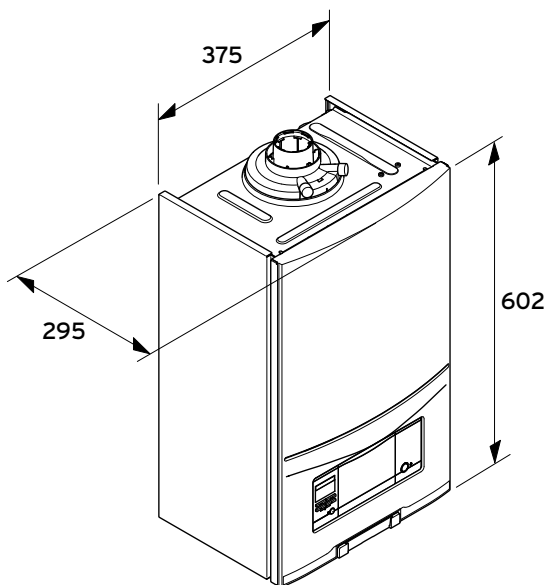

Clearances:

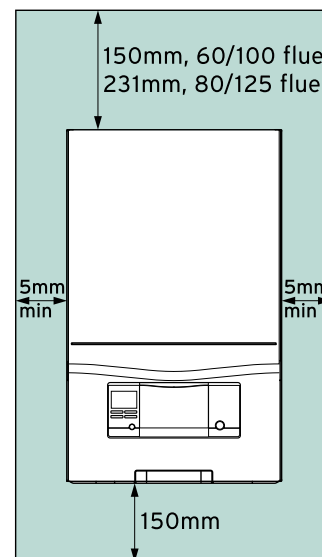

Note: A 600mm front clearance is recommended to allow easy access during inspection and maintenance

Technical data

Technical data	Unit of measure	ecoTEC exclusive 835	ecoTEC exclusive 843
General			
Boiler type		Combi	
Signature model output	kW	35	43
Article number		0010017064	0010017065
Gas Council number		47-044-66	47-044-67
Boiler dimensions (HxWxD)	mm	720 x 440 x 406	720 x 440 x 474
Performance			
NOx (En 15502-2-1)	mg/kWh	35	36
ErP efficiency (heating / DHW)	A+++ - D / A+ - F	A / A	
ErP efficiency	%	94	
ErP decibel rating (sound power)	dBa	43	51
Heating			
Nominal heat output range at 50/30 °C (condensing mode)	kW	3.9 - 26.4	4.8 - 36.0
Nominal heat output range at 80/60 °C (non condensing mode)	kW	3.4 - 24.6	4.3 - 33.4
Maximum flow temperature	°C	85	
Flow temperature range	°C	30 - 80	
Flow temperature factory setting	°C	75	
Approximate condensate volume at 50/30 °C	Litres/hr	2.48	3.37
Modulation (max/min)	1 : X	1:10.4	1:10.1
Domestic hot water			
Maximum heat output for water generation	kW	35.3	43.4
Lowest water pressure to operate boiler	Bar	0.35	
Lowest water flow for operation	l/min	1.5	
Lowest water pressure for maximum flow rate	Bar	0.8	
Domestic hot water flow rate (at $\Delta t = 35K$)	l/min	14.5	17.8
Domestic hot water flow rate (at $\Delta t = 45K$)*	l/min	11.2	13.8
Hot water output temperature range	°C	35 - 65	
Mechanical			
Expansion vessel size	Litres	10	
Gas inlet connection (pipe size)	mm	15	20
Heating flow and return connections (pipe size)	mm	22	
Hot and cold water connections (pipe size)	mm	15	
Heat exchanger material	Stainless/Aluminium	Stainless steel	
Boiler lift weight (dry boiler)	kg	47.5	55.0
Maximum horizontal flue length 60/100	m	5.5	
Rear flue options	Yes/No	No	
Permissible flue classifications		C13, C33, C53	
Minimum clearances			
Side left and right	mm	5	
Top	mm	165	
Top (if using rear flue)	mm	-	
Below	mm	180	300
Front	mm	500	

*Achieved via fitment of a flow restrictor

Technical data	Unit of measure	ecoTEC plus 825	ecoTEC plus 832	ecoTEC plus 832 LPG	ecoTEC plus 835	ecoTEC plus 838
General						
Boiler type		Combi				
Signature model output	kW	25	32	32	35	38
Article number		0010021823	0010021824	0010021825	0010021822	0010021826
Gas Council number		47-044-83	47-044-84	47-044-85	47-044-82	47-044-86
Boiler dimensions (HxWxD)	mm	720 x 440 x 338			720 x 440 x 372	720 x 440 x 406
Performance						
NOx (En 15502-2-1)	mg/kWh	32	35	55	29	34
ErP efficiency (heating / DHW)	A+++ - D / A+ - F	A / A				
ErP efficiency	%	94				
ErP decibel rating (sound power)	dBa	47			46	45
Heating						
Nominal heat output range at 50/30°C (condensing mode)	kW	4.1 - 20.8	5.7 - 26.4	6.5 - 25.5	6.4 - 32.8	7.1 - 30.9
Nominal heat output range at 80/60°C (non condensing mode)	kW	3.8 - 19.3	5.2 - 24.4	6.0 - 24.4	5.8 - 30.4	6.5 - 28.6
Maximum flow temperature	°C	85				
Flow temperature range	°C	30 - 80				
Flow temperature factory setting	°C	75				
Approximate condensate volume at 50/30°C	Litres/hr	2.0	2.5		3.1	2.9
Modulation (max/min)	1 : X	1:6.7	1:6.1	1:5.3	1:6.0	1:6.0
Domestic hot water						
Maximum heat output for water generation	kW	25.4	31.8		35.0	38.7
Lowest water pressure to operate boiler	Bar	0.35				
Lowest water flow for operation	l/min	2				
Lowest water pressure for maximum flow rate	Bar	0.8				
Domestic hot water flow rate (at Δt = 35K)	l/min	10.5	13.0		14.3	15.9
Domestic hot water flow rate (at Δt = 42K)*	l/min	8.8	10.9		11.9	13.2
Hot water output temperature range	°C	35 - 65				
Mechanical						
Expansion vessel size	Litres	10				
Gas inlet connection (pipe size)	mm	15				
Heating flow and return connections (pipe size)	mm	22				
Hot and cold water connections (pipe size)	mm	15				
Heat exchanger material	Stainless/Aluminium	Stainless steel				
Boiler lift weight (dry boiler)	kg	36	37		41	44
Maximum horizontal flue length 60/100	m	12	5.5			
Rear flue options	Yes/No	No				
Permissible flue classifications		C13, C33, C43, C53				
Minimum clearances						
Side left and right	mm	5				
Top	mm	165				
Top (if using rear flue)	mm	-				
Below	mm	180				
Front	mm	500				

*Achieved via fitment of a flow restrictor

Technical data	Unit of measure	ecoTEC plus 938
General		
Boiler type		Storage combi
Signature model output	kW	38
Article number		0010021827
Gas Council number		47-044-87
Boiler dimensions (HxWxD)	mm	720 x 440 x 624
Performance		
NOx (En 15502-2-1)	mg/kWh	34
ErP efficiency (heating / DHW)	A+++ - D / A+ - F	A / A
ErP efficiency	%	94
ErP decibel rating (sound power)	dBa	45
Heating		
Nominal heat output range at 50/30 °C (condensing mode)	kW	7.1 - 30.9
Nominal heat output range at 80/60 °C (non condensing mode)	kW	6.5 - 28.6
Maximum flow temperature	°C	85
Flow temperature range	°C	30 - 80
Flow temperature factory setting	°C	75
Approximate condensate volume at 50/30 °C	Litres/hr	2.9
Modulation (max/min)	1 : X	1:6.0
Domestic hot water		
Maximum heat output for water generation	kW	38.7
Lowest water pressure to operate boiler	Bar	0.35
Lowest water flow for operation	l/min	2
Lowest water pressure for maximum flow rate	Bar	0.8
Domestic hot water flow rate (at $\Delta t = 35K$)	l/min	15.9
Domestic hot water flow rate (at $\Delta t = 42K$)*	l/min	13.2
Hot water output temperature range	°C	35 - 65
Mechanical		
Expansion vessel size	Litres	10
Gas inlet connection (pipe size)	mm	15
Heating flow and return connections (pipe size)	mm	22
Hot and cold water connections (pipe size)	mm	15
Heat exchanger material	Stainless/Aluminium	Stainless steel
Boiler lift weight (dry boiler)	kg	43+17
Maximum horizontal flue length 60/100	m	5.5
Rear flue options	Yes/No	No
Permissible flue classifications		C13, C33, C43, C53
Minimum clearances		
Side left and right	mm	5
Top	mm	165
Top (if using rear flue)	mm	-
Below	mm	180
Front	mm	500

*Achieved via fitment of a flow restrictor

Technical data	Unit of measure	ecoTEC pro 24	ecoTEC pro 28	ecoTEC pro 28 LPG	ecoTEC pro 30
General					
Boiler type		Combi			
Signature model output	kW	24	28		30
Article number		0010021836	0010021837	0010021838	0010016538
Gas Council number		47-044-88	47-044-89	47-044-90	47-044-52
Boiler dimensions (HxWxD)	mm	720 x 440 x 338			
Performance					
NOx (En 15502-2-1)	mg/kWh	27		28	30
ErP efficiency (heating / DHW)	A+++ - D / A+ - F	A / A			
ErP efficiency	%	94			93
ErP decibel rating (sound power)	dBa	49			
Heating					
Nominal heat output range at 50/30°C (condensing mode)	kW	5.9 - 24.8	5.9 - 25.9	7.9 - 25.3	6.9 - 25.7
Nominal heat output range at 80/60°C (non condensing mode)	kW	5.2 - 23.0	5.2 - 24	7.2 - 24.0	8.0 - 24.7
Maximum flow temperature	°C	85			
Flow temperature range	°C	30 - 80			
Flow temperature factory setting	°C	75			
Approximate condensate volume at 50/30°C	Litres/hr	19			2.5
Modulation (max/min)	1 : X	1:4.3	1:5	1:3.6	1:3.8
Domestic hot water					
Maximum heat output for water generation	kW	23.5	27.5	27.5	30.0
Lowest water pressure to operate boiler	Bar	0.3			
Lowest water flow for operation	l/min	2			
Lowest water pressure for maximum flow rate	Bar	0.8			
Domestic hot water flow rate (at Δt = 35K)	l/min	9.6	11.1	11.1	12.3
Domestic hot water flow rate (at Δt = 42K)*	l/min	8.0	9.3		10.2
Hot water output temperature range	°C	35 - 65			
Mechanical					
Expansion vessel size	Litres	8			
Gas inlet connection (pipe size)	mm	15			
Heating flow and return connections (pipe size)	mm	22			
Hot and cold water connections (pipe size)	mm	15			
Heat exchanger material	Stainless/ Aluminium	Stainless steel			
Boiler lift weight (dry boiler)	kg	38			39
Maximum horizontal flue length 60/100	m	12			
Rear flue options	Yes/No	No			
Permissible flue classifications		C13, C33, C43, C53			
Minimum clearances					
Side left and right	mm	5			
Top	mm	165			
Top (if using rear flue)	mm	-			
Below	mm	180			
Front	mm	500			

*Achieved via fitment of a flow restrictor

Technical data	Unit of measure	ecoFIT pure 825	ecoFIT pure 830	ecoFIT pure 835
General				
Boiler type		Combi		
Signature model output	kW	25	30	35
Article number		0010020389	0010020390	0010020391
Gas Council number		47-044-68	47-044-74	47-044-70
Boiler dimensions (HxWxD)	mm	700 x 390 x 295		
Performance				
NOx (En 15502-2-1)	mg/kWh	39	39	39
ErP efficiency (heating / DHW)	A+++ - D / A+ - F	A / A		
ErP efficiency	%	94		
ErP decibel rating (sound power)	dBa	49	51	52
Heating				
Nominal heat output range at 50/30 °C (condensing mode)	kW	5.3 - 19.1	6.3 - 26.5	7.5 - 26.7
Nominal heat output range at 80/60 °C (non condensing mode)	kW	5.0 - 18.3	6.1 - 25.4	7.2 - 25.6
Maximum flow temperature	°C	80		
Flow temperature range	°C	10-80		
Flow temperature factory setting	°C	75		
Approximate condensate volume at 50/30 °C	Litres/hr	1.84	2.55	2.57
Modulation (max/min)	1 : X	1:5.1	1:4.9	1:5
Domestic hot water				
Maximum heat output for water generation	kW	25.2	30	35
Lowest water pressure to operate boiler	Bar	0.3		
Lowest water flow for operation	l/min	2		
Lowest water pressure for maximum flow rate	Bar	2		
Domestic hot water flow rate (at Δt = 35K)	l/min	10.4	12.2	14.1
Domestic hot water flow rate (at Δt = 42K)*	l/min	8.0	10.4	12.0
Hot water output temperature range	°C	35 - 60		
Mechanical				
Expansion vessel size	Litres	8		
Gas inlet connection (pipe size)	mm	15		
Heating flow and return connections (pipe size)	mm	22		
Hot and cold water connections (pipe size)	mm	15		
Heat exchanger material	Stainless/ Aluminium	Aluminium		
Boiler lift weight (dry boiler)	kg	32	33	
Maximum horizontal flue length 60/100	m	10		
Rear flue options	Yes/No	Yes		
Permissible flue classifications		C13, C33, C43, C53		
Minimum clearances				
Side left and right	mm	5		
Top	mm	150		
Top (if using rear flue)	mm	20		
Below	mm	150		
Front	mm	500		

*Achieved via fitment of a flow restrictor

Technical data	Unit of measure	ecoTEC exclusive 627
General		
Boiler type		System
Signature model output	kW	27
Article number		0010017063
Gas Council number		41-694-02
Boiler dimensions (HxWxD)	mm	720 x 440 x 338
Performance		
NOx (En 15502-2-1)	mg/kWh	30
ErP efficiency (heating)	A+++ - D	A
ErP efficiency	%	94
ErP decibel rating (sound power)	dBa	46
Heating		
Nominal heat output range at 50/30°C (condensing mode)	kW	3.4 - 26.7
Nominal heat output range at 80/60°C (non condensing mode)	kW	3.0 - 24.7
Maximum flow temperature	°C	85
Flow temperature range	°C	30 - 80
Flow temperature factory setting	°C	75
Approximate condensate volume at 50/30°C	Litres/hr	2.52
Modulation (max/min)	1 : X	1:8.9
Mechanical		
Expansion vessel size	Litres	10
Gas inlet connection (pipe size)	mm	15
Heating flow and return connections (pipe size)	mm	22
Heat exchanger material	Stainless/Aluminium	Stainless steel
Boiler lift weight (dry boiler)	kg	37.5
Maximum horizontal flue length 60/100	m	5.5
Rear flue options	Yes/No	No
Permissible flue classifications		C13, C33, C53
Minimum clearances		
Side left and right	mm	5
Top	mm	165
Top (if using rear flue)	mm	-
Below	mm	180
Front	mm	500

Technical data	Unit of measure	ecoTEC plus 612	ecoTEC plus 615	ecoTEC plus 618	ecoTEC plus 618 LPG	ecoTEC plus 624	ecoTEC plus 630	ecoTEC plus 630 LPG	ecoTEC plus 637	
General										
Boiler type		System								
Signature model output	kW	12	15	18		24	30		37	
Article number		0010021828	0010021829	0010021830	0010021831	0010021832	0010021833	0010021834	0010021835	
Gas Council number		41-694-20	41-694-21	41-694-22	41-694-23	41-694-24	41-694-25	41-694-26	41-694-27	
Boiler dimensions (HxWxD)	mm	720 x 440 x 338					720 x 440 x 372		720 x 440 x 406	
Performance										
NOx (En 15502-2-1)	mg/kWh	23	23	29	39	35	29	64	36	
ErP efficiency (heating)	A+++ - D	A								
ErP efficiency	%	94								
ErP decibel rating (sound power)	dBa	43		47			46		50	
Heating										
Nominal heat output range at 50/30°C (condensing mode)	kW	3.3 - 13.2	3.3 - 16.7	4.1 - 20.0	5.4 - 19.4	5.7 - 26.4	6.4 - 32.8	9.4 - 31.9	7.1 - 40.5	
Nominal heat output range at 80/60°C (non condensing mode)	kW	3.0 - 12.2	3.0 - 15.2	3.8 - 18.2	5.0 - 18.2	5.2 - 24.4	5.8 - 30.4	8.5 - 30.4	6.4 - 37.6	
Maximum flow temperature	°C	85								
Flow temperature range	°C	30 - 80								
Flow temperature factory setting	°C	75								
Approximate condensate volume at 50/30°C	Litres/hr	1.2	1.6	1.9		2.5	3.1		3.8	
Modulation (max/min)	1 : X	1:4.1	1:5.1	1:4.9	1:3.7	1:4.7	1:5.2		1:5.9	
Mechanical										
Expansion vessel size	litres	10								
Gas inlet connection (pipe size)	mm	15								
Heating flow and return connections (pipe size)	mm	22								
Heat exchanger material		Stainless steel								
Boiler lift weight (dry boiler)	kg	36				37	38		43	
Maximum horizontal flue length 60/100	m	22.0		12.0		5.5				
Rear flue options	Yes/No	No								
Permissible flue classifications		C13, C33, C43, C53								
Minimum clearances										
Side left and right	mm	5								
Top	mm	165								
Top (if using rear flue)	mm	-								
Below	mm	180								
Front	mm	500								

Technical data	Unit of measure	ecoTEC plus 48	ecoTEC plus 64
General			
Boiler type		System	
Signature model output	kW	48	64
Article number		0010021520	0010021521
Gas Council number		41-694-28	41-694-29
Boiler dimensions (HxWxD)	mm	720 x 440 x 405	720 x 440 x 473
Performance			
NOx (En 15502-2-1)	mg/kWh	30.8	29.1
ErP efficiency* (heating)	A+++ - D	A+	
ErP efficiency	%	94	
ErP decibel rating (sound power)	dBa	56.5	
Heating			
Nominal heat output range at 50/30°C (condensing mode)	kW	8.7 - 48.0	12.2 - 63.5
Nominal heat output range at 80/60°C (non condensing mode)	kW	7.8 - 44.1	11.0 - 58.7
Conversion to LPG G31 at 37mb at 50/30°C (Conversion kit by installer on site necessary)	kW	8.6 - 46.6	12.0 - 62.1
Conversion to LPG G31 at 37mb at 80/60°C ((Conversion kit by installer on site necessary)	kW	7.8 - 44.0	11.0 - 58.4
Maximum flow temperature	°C	80	
Flow temperature range	°C	30 - 80	
Flow temperature factory setting	°C	75	
Approximate condensate volume at 50/30°C	Litres/hr	5.0	6.9
Modulation (max/min)	1 : X	1:5.5 (18%)	1:5.2 (19%)
Lowest water pressure to operate boiler	bar	0.8	
Nominal flow rate (at DT = 20K)	l/hr	1900	2500
Mechanical			
Expansion vessel size	Litres	Available as an accessory	
Gas inlet connection (pipe size)	BSP female	1"	
Heating flow and return connections (pipe size)	BSP female	1 1/4"	
Heat exchanger material	Stainless/Aluminium	Stainless steel	
Boiler lift weight (dry boiler - includes pump)	kg	38	48
Maximum horizontal flue length 80/125	m	18	15
Maximum vertical flue length 80/125	m	21	18
Rear flue options	Yes/No	No	
Permissible flue classifications		C13, C33, C43, C53, C93, B23, B23p, B53, B53p	
Minimum clearances			
Side left and right	mm	5	
Top	mm	350	
Top (if using rear flue)	mm	-	
Below	mm	400	
Front	mm	500	

*When installed with a VRC 700

Technical data	Unit of measure	ecoFIT pure 612	ecoFIT pure 615	ecoFIT pure 618	ecoFIT pure 625	ecoFIT pure 630
General						
Boiler type		System				
Signature model output	kW	12	15	18	25	30
Article number		0010020395	0010020396	0010020397	0010020398	0010020399
Gas Council number		41-694-03	41-694-04	41-694-05	41-694-06	41-694-07
Boiler dimensions (HxWxD)	mm	700 x 390 x 295				
Performance						
NOx (En 15502-2-1)	mg/kWh	32	33	39		40
ErP efficiency (heating)	A+++ - D	A				
ErP efficiency	%	94				
ErP decibel rating (sound power)	dBa	45	48	49	51	54
Heating						
Nominal heat output range at 50/30 °C (condensing mode)	kW	4.7 - 12.8	4.7 - 15.9	5.2 - 19.1	6.4 - 26.5	7.5 - 31.8
Nominal heat output range at 80/60 °C (non condensing mode)	kW	4.5 - 12.3	4.5 - 15.2	5.0 - 18.3	6.1 - 25.4	7.2 - 30.5
Maximum flow temperature	°C	80				
Flow temperature range	°C	10 - 80				
Flow temperature factory setting	°C	75				
Approximate condensate volume at 50/30 °C	Litres/hr	1.23	1.53	1.84	2.55	3.06
Modulation (max/min)	1 : X	1:3.3	1:4	1:5	1:4.9	1:4.9
Mechanical						
Expansion vessel size	Litres	8				
Gas inlet connection (pipe size)	mm	15				
Heating flow and return connections (pipe size)	mm	22				
Heat exchanger material	Stainless/Aluminium	Aluminium				
Boiler lift weight (dry boiler)	kg	31			32	
Maximum horizontal flue length 60/100	m	10				
Rear flue options	Yes/No	Yes				
Permissible flue classifications		C13, C33, C43, C53				
Minimum clearances						
Side left and right	mm	5				
Top	mm	150				
Top (if using rear flue)	mm	20				
Below	mm	150				
Front	mm	500				

Technical data	Unit of measure	ecoTEC plus 412	ecoTEC plus 415	ecoTEC plus 418	ecoTEC plus 424	ecoTEC plus 424 LPG	ecoTEC plus 430	ecoTEC plus 435
General								
Boiler type		Open vent						
Signature model output	kW	12	15	18	24		30	35
Article number		0010021220	0010021221	0010021222	0010021223	0020231355	0010021224	0010015674
Gas Council number		41-694-13	41-694-14	41-694-15	41-694-16	41-694-18	41-694-17	41-044-76
Boiler dimensions (HxWxD)	mm	602 x 375 x 320						
Performance								
NOx (En 15502-2-1)	mg/kWh	32	33	39	39	35	40	29
ErP efficiency (heating)	A+++ - D	A						
ErP efficiency	%	94						93
ErP decibel rating (sound power)	dBa	45	48	51	52	49	55	53
Heating								
Nominal heat output range at 50/30°C (condensing mode)	kW	4.7 - 12.8	4.7 - 15.9	5.2 - 19.1	6.3 - 25.7	8.0 - 25.7	7.5 - 31.8	7.5 - 37.1
Nominal heat output range at 80/60°C (non condensing mode)	kW	4.5 - 12.3	4.5 - 15.2	5.0 - 18.3	6.1 - 24.6	7.6 - 24.3	7.2 - 30.5	7.1 - 35.1
Maximum flow temperature	°C	80						
Flow temperature range	°C	10 - 80						
Flow temperature factory setting	°C	75						
Approximate condensate volume at 50/30°C	Litres/hr	1.23	1.53	1.84	2.47		3.06	3.57
Modulation (max/min)	1 : X	1:2.8	1:3.5	1:3.8	1:4.2	1:3.4	1:4.4	1:5.2
Mechanical								
Gas inlet connection (pipe size)	mm	15						
Heating flow and return connections (pipe size)	mm	22						
Heat exchanger material		Aluminium						
Boiler lift weight (dry boiler)	kg	23.0			23.8			
Maximum horizontal flue length 60/100	m	10				0.7*	10	
Rear flue options	Yes/No	Yes				No	Yes	
Permissible flue classifications		C13, C33, C43, C53 (LPG option can only be fitted with top horizontal flue supplied)						
Minimum clearances								
Side left and right	mm	5						
Top	mm	150						
Top (if using rear flue)	mm	75						
Below	mm	150						
Front	mm	500						

*Cannot be extended with any other standard Vaillant flue component. 0.7m flue is supplied with this boiler.

Technical data	Unit of measure	ecoFIT pure 412	ecoFIT pure 415	ecoFIT pure 418	ecoFIT pure 425	ecoFIT pure 430	ecoFIT pure 435
General							
Boiler type		Open vent					
Signature model output	kW	12	15	18	25	30	35
Article number		0010020400	0010020401	0010020402	0010020403	0010020404	0010020405
Gas Council number		41-694-08	41-694-09	41-694-10	41-694-11	41-694-12	41-694-19
Boiler dimensions (HxWxD)	mm	602 x 375 x 295					
Performance							
NOx (En 15502-2-1)	mg/kWh	32	33	39	39	40	32
ErP efficiency (heating)	A+++ - D	A					
ErP efficiency	%	94					
ErP decibel rating (sound power)	dBa	45	48	51	52	55	
Heating							
Nominal heat output range at 50/30°C (condensing mode)	kW	4.7 - 12.8	4.7 - 15.9	5.2 - 19.1	6.4 - 26.5	7.4 - 31.8	7.0 - 35.8
Nominal heat output range at 80/60°C (non condensing mode)	kW	4.5 - 12.3	4.5 - 15.2	5.0 - 18.3	6.1 - 25.4	7.1 - 30.5	7.2 - 34.8
Maximum flow temperature	°C	80					
Flow temperature range	°C	10 - 80					
Flow temperature factory setting	°C	75					
Approximate condensate volume at 50/30°C	Litres/hr	1.23	1.53	1.84	2.55	3.06	3.65
Modulation (max/min)	1 : X	1:3.3	1:4	1:5	1:4.9		
Mechanical							
Gas inlet connection (pipe size)	mm	15					
Heating flow and return connections (pipe size)	mm	22					
Heat exchanger material	Stainless/ Aluminium	Aluminium					
Boiler lift weight (dry boiler)	kg	22					23
Maximum horizontal flue length 60/100	m	10					
Rear flue options	Yes/No	Yes					
Permissible flue classifications		C13, C33, C43, C53					
Minimum clearances							
Side left and right	mm	5					
Top	mm	150					
Top (if using rear flue)	mm	20					
Below	mm	150					
Front	mm	500					

Terminal clearances

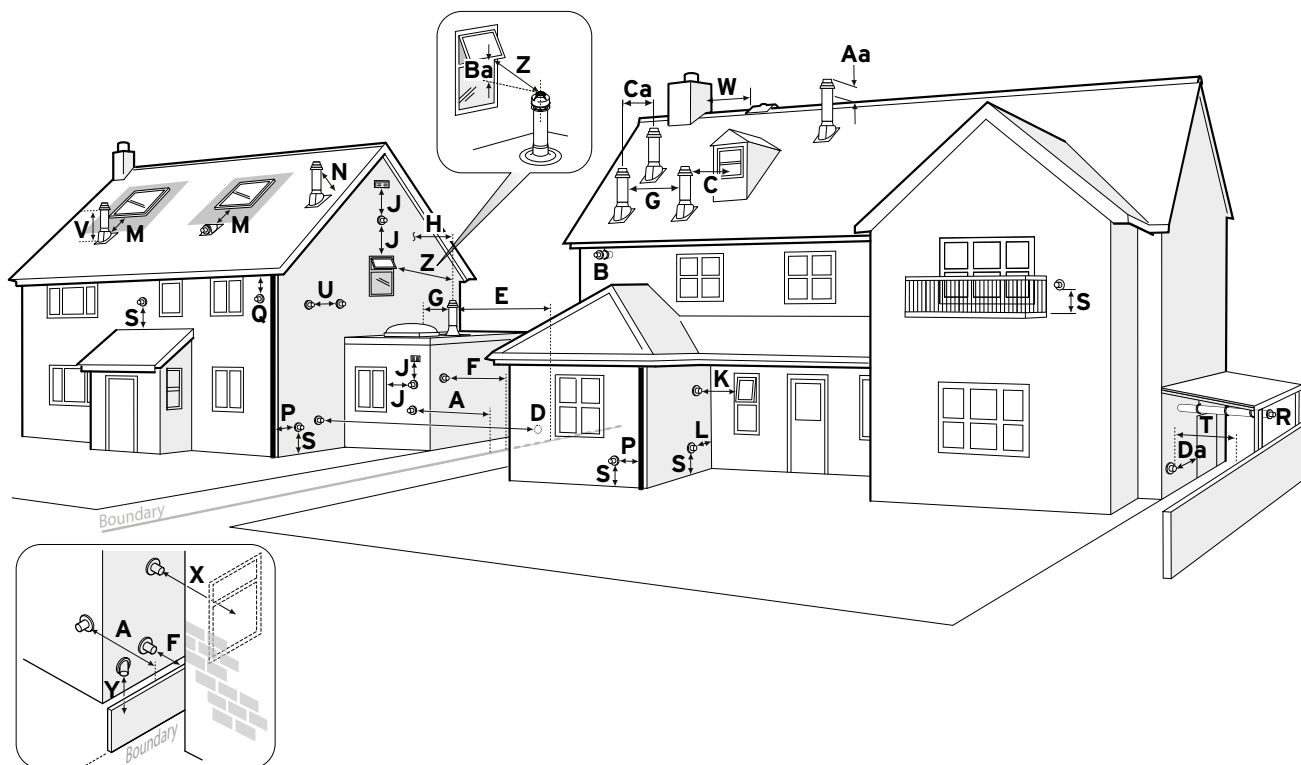

A	300	300mm adjacent to a boundary.
B	25 ⁽¹⁾	The dimension below eaves, balconies and car ports can be reduced to 25mm, as long as the flue terminal is extended to clear any overhang. External flue joints must be sealed with a suitable silicon sealant.
C	1500	1500mm between a vertical flue terminal and a window or dormer window on a roof.
D	1200	1200mm between terminals facing each other.
E	300	Vertical flue clearance, 300mm adjacent to a boundary line.
F ⁽²⁾	600	600mm distance to a boundary line, unless it will cause a nuisance. BS 5440:Part 1 recommends that care is taken when siting terminal in relation to boundary lines.
G	300	300mm minimum clearance from a skylight to a vertical flue or to another adjacent vertical flue.
H	500 1500	Vertical flue clearance, 500mm to non-combustible building material, and 1500mm clearance to combustible building material.
J	300	300mm above, below and either side of an opening door, air vent or opening window.
K	600	600mm diagonally to an opening door, air vent or opening window.
L ⁽²⁾	200	200mm to an internal or external corner.*
M	2000	2000mm below a Velux window, 600mm above or to either side of the Velux window.
N	400	400mm from a pitched roof or 500mm in regions with heavy snowfall.
P	25	25mm from vertical drain pipes and soil pipes.
Q ⁽¹⁾	200	200mm below eaves and 75mm below gutters, pipe and drains. (see also 'R')

R	25	The dimension below eaves, balconies and car ports can be reduced to 25mm, as long as the flue terminal is extended to clear any overhang. External flue joints must be sealed with suitable silicon sealant.
S	300	300mm above adjacent ground or balcony.
T ⁽²⁾	600	600mm distance to a surface facing a terminal, unless it will cause a nuisance. BS 5440: Part 1 recommends that care is taken when siting terminals in relation to surfaces facing a terminal.
U	300	300mm clearance alongside another terminal.
V	300	300mm above roof level.
W	300	300mm min to vertical structure on roof, roof vent
X	2000	2000mm min. to opening in adjacent building
Y	600	600mm min. at an angle to a boundary which is not less than 300mm to the terminal
Z	600	600mm min. measured to the nearest corner of the OPEN window
Aa	300	No more than 300mm above ridge
Ba	300	Not less than 300mm below the opening window
Ca	600	600mm between vertical flues
Da	1200	From an opening (e.g. door window etc.) in eaves, balconies, car ports and overhangs

- (2) These dimensions comply with the building regulations, but they may need to be increased to avoid wall staining and nuisance from plumbing depending on site conditions.
- All measurements are the minimum clearances required.
 - Terminals must be positioned so to avoid combustion products entering the building.
 - Support the flue at approximately one metre intervals and at a change of direction, use suitable brackets and fixings.
 - Installations in car ports are not recommended.
 - The flue cannot be lower than 1 metre from the top of a lightwell due to the build up of combustion products.
 - Dimensions from a flue terminal to a fanned air inlet to be determined by the ventilation equipment
 - The terminal clearances are only applicable where the appliance has been installed, commissioned and maintained inline with the manufacturer's instructions

* This distance can be reduced to 25mm by using a plume kit or diverter and being angled at 45° to avoid staining.

Note: Terminal must NOT terminate under roof or car port. Car port must have at least two open sides.

(1) There should be no ventilation/opening in the eaves within 300mm distance of the terminal.

Flue lengths

Technical data	Horizontal flues		Vertical flues	
	60/100 DN	80/125 DN	60/100 DN	80/125 DN
Diameter				
Combi boilers				
ecoTEC exclusive 835 and 843	5.5m	32m	8m	34m
ecoTEC plus 825	12m	39m	16m	41m
ecoTEC plus 832, 835, 838 and 938	5.5m	32m	8m	34m
ecoTEC pro 24, 28 and 30	12m	39m	16m	41m
ecoFIT pure 825, 830 and 835	10m	25m	10m	25m
System boilers				
ecoTEC exclusive 627	5.5m	32m	8m	34m
ecoTEC plus 612 and 615	22m	25m	26m	27m
ecoTEC plus 618	12m	39m	16m	41m
ecoTEC plus 624, 630 and 637	5.5m	32m	8m	34m
ecoTEC plus 48	-	18m	-	21m
ecoTEC plus 64	-	15m	-	18m
ecoFIT pure 612, 615, 618, 625 and 630	10m	25m	10m	25m
Open vent boilers				
ecoTEC plus 412, 415, 418, 425, 430 and 435	10m	25m	10m	25m
ecoFIT pure 412, 415, 418, 425, 430 and 435	10m	25m	10m	25m

Please note: there will be reductions in the maximum length of flues if elbows etc are required in the design. See the individual flue guides for further information.

Flue solutions

Flue accessories

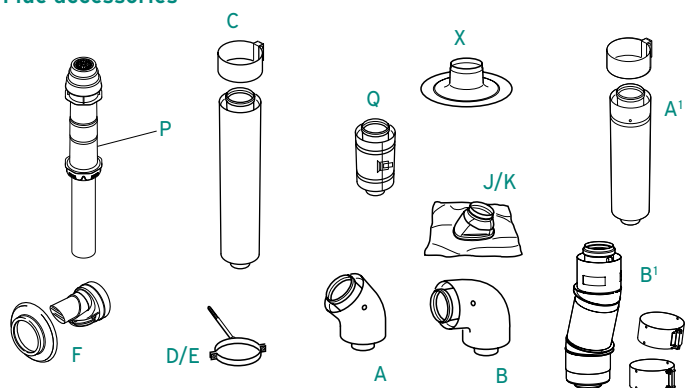

Variable termination kits (Not for 80/125 flues or ecoTEC 48/64 boilers)

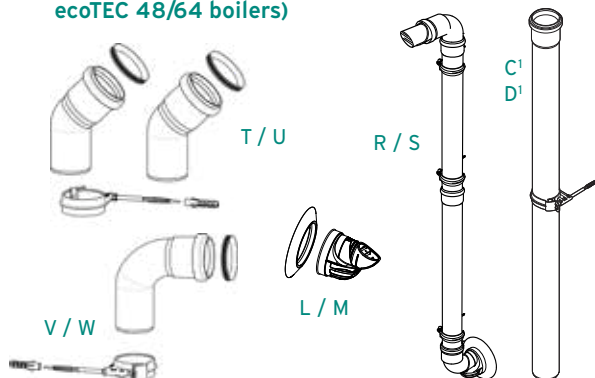

Horizontal flue configuration examples

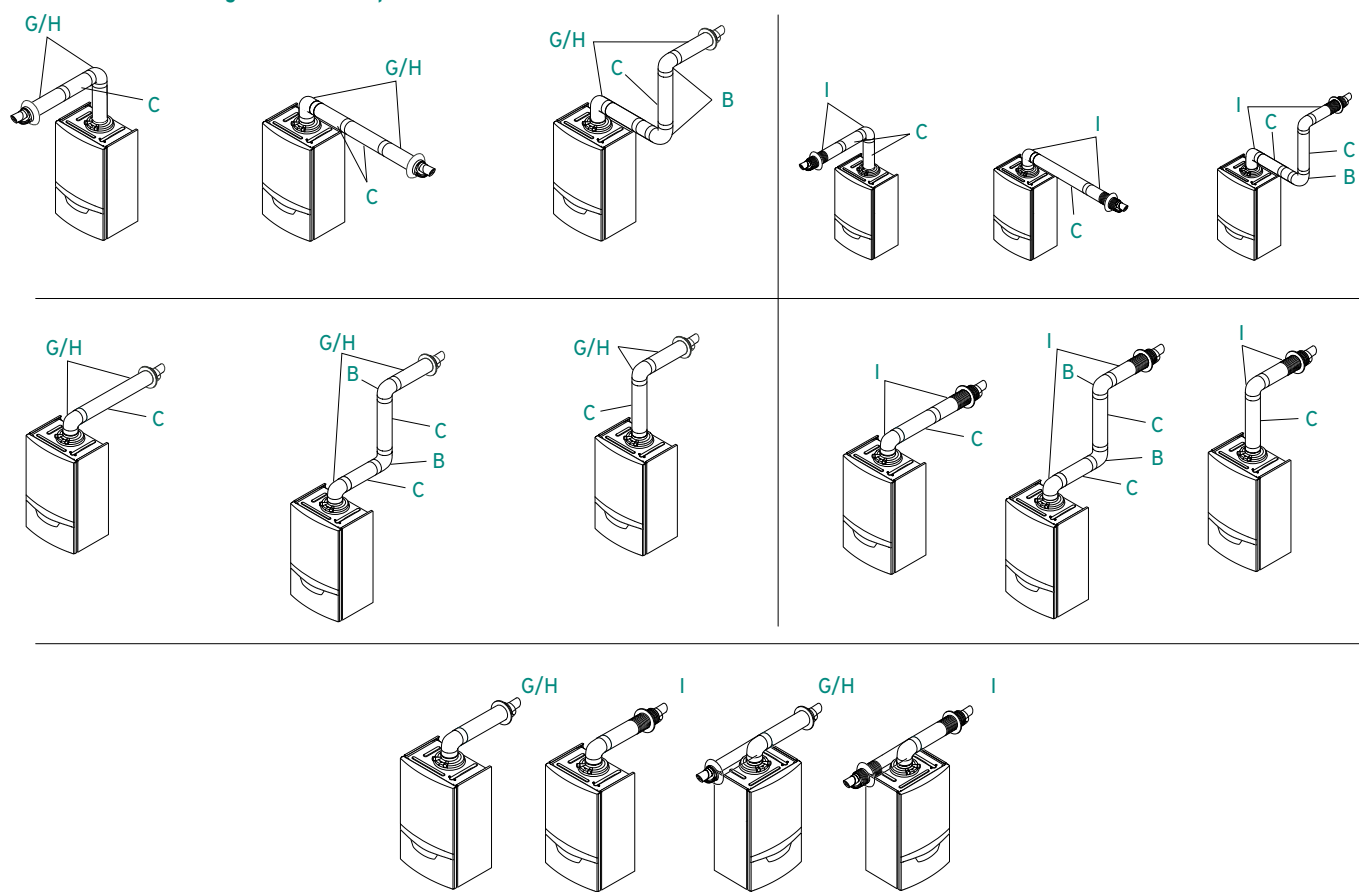

Vertical flue configuration examples

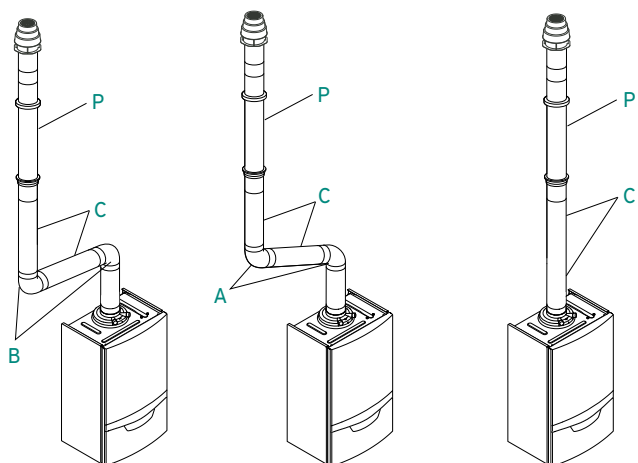

Rear flue configuration (ecoFIT pure and ecoTEC plus open vent only)

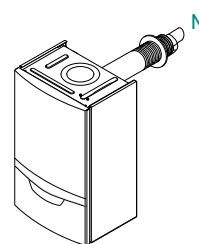

60/100 and 80/125 DN flue components

Component	Description	Part number	
		60/100 DN	80/125 DN
A	Bends 45° (pack of 2)	303911	303211
B	Elbow 87°	303910	303210
C	Extension 0.5 m DN60/100	303902	303202
	Extension 1.0m DN60/100	303903	303203
	Extension 2.0m DN60/100	303905	303205
	Extension 4.0m DN60/100	0020138174	-
D	Fixing clamp (140mm thread length) (pack of 5) DN60/100	303821	303616
E	Flue support clips (250mm thread length) (pack of 3) DN60/100	303935	-
F	Flue terminal kit (black)	0020219537	-
G	Horizontal flue kit 1.7m	0020219519	-
H	Horizontal flue kit 0.7m (Comprehensive range)	0020219517	303209
	Horizontal flue kit 0.7m (Simple range)	303933	-
I	Horizontal telescopic flue kit	0020219518	-
J	Pitched roof tile flexible (black)	303980	
K	Pitched weather collar	009076	
L	Plume deflector kit (black) (Not for ecoTEC exclusive)	0020219533	-
M	Plume deflector kit (white) (Not for ecoTEC exclusive)	0020219534	-
N	Rear telescopic flue kit	0020228140	-
P	Roof terminal (black)	0020223472	0020030797
Q	Sliding sleeve	303915	303215
R	Variable termination kit (black)	0020219529	-
S	Variable termination kit (white)	0020219530	-
T	VTK elbow 45° (pack of 2) - (black)	0020219551	-
U	VTK elbow 45° (pack of 2) - (white)	0020219552	-
V	VTK elbow 87° (black)	0020219543	-
W	VTK elbow 87° (white)	0020219544	-
X	Flat roof weather collar	009056	
A'	Telescopic flue extension (500 - 800mm)	303906	
B'	Telescopic offset flue DN60/100	303919	
C'	VTK extension 1.0m black	0020219539	
D'	VTK extension 1.0m white	0020219540	

Stainless steel 80/125mm facade flue

Maximum facade flue length

ecoTEC plus	48kW	64kW
Maximum permissible length of concentric flue gas pipe	22.0m (includes 3 x 87° elbows and support elbow)	22.0m (includes 3 x 87° elbows and support elbow)

Air intake piece must be positioned no further than 4m from the connection with the boiler.

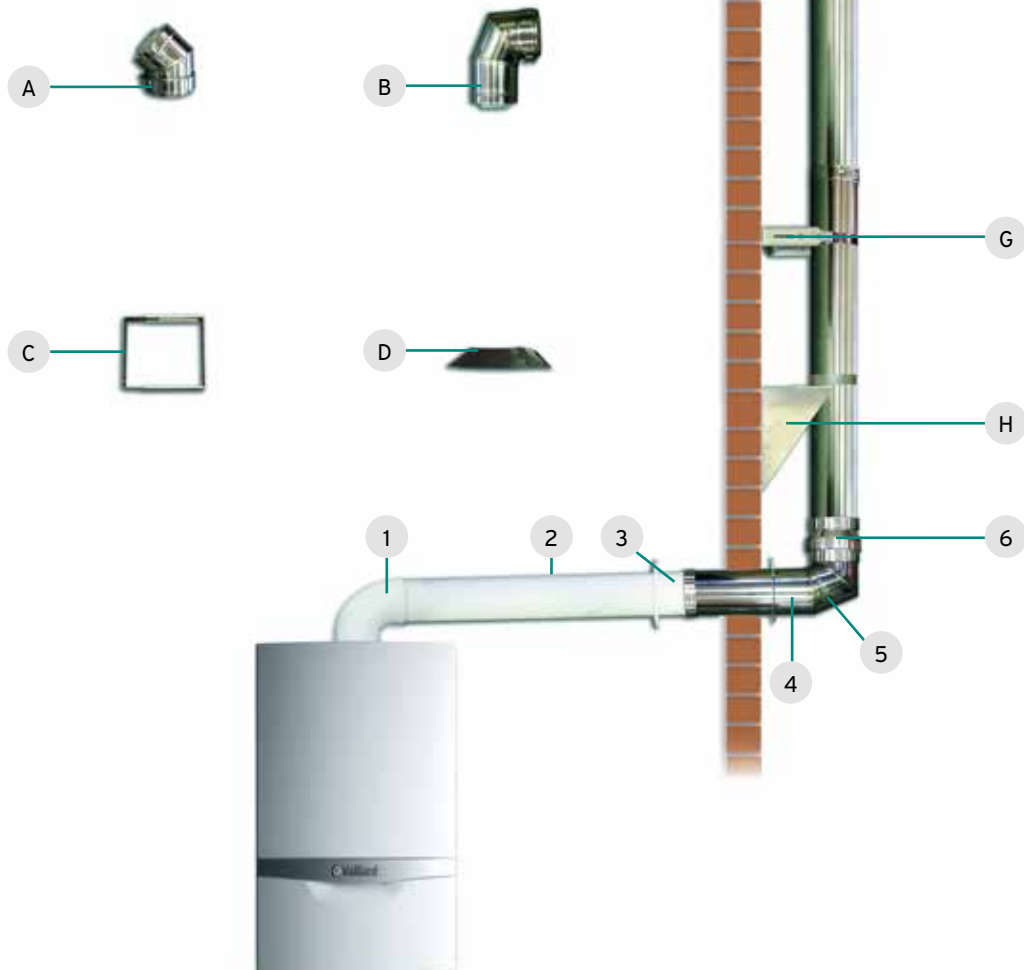

80/125mm concentric stainless steel facade flue

Key	80/125mm facade flue	Article number	Key	Facade basic connection set	Article number
A	45° elbow (pack of 2)*	0020042757	1	87° elbow	0020042748
B	87° elbow (pack of 1)*	0020042756	2	Transition piece	
C	Fixing bracket extension	0020042752	3	Inner wall rosette	
D	Rain collar	0020042760	4	Outer wall rosette	
E	1.0m extension	0020042754	5	Wall penetration elbow	
	0.5m extension	0020042753	6	Air intake piece	
	0.5m adjustable extension	0020042755	7	Bird guard terminal	
F	Fixing bracket	0020042751			
G					
H	Adjustable wall support for heights over 4m	0020042749			

*Can be used to terminate horizontally

Controls



Controls are an essential part of all heating systems

We always recommend our appliances are fitted with a Vaillant control. Vaillant has a wide range of controls and each uses eBUS, technology that enables each element of a Vaillant system to communicate to ensure it's always working with ultimate efficiency.

Vaillant's controls range from simple analogue controls to app-controlled models that can be integrated with smart home systems and alert you to faults. All of our controls come with load compensation as standard. Every Vaillant heating appliance can be matched with the perfect control to ensure compliance with Boiler Plus legislation.

As well as allowing the user to choose the times their heating and/or hot water switches on or off, controls can set preferred temperature parameters. Controls can also monitor weather conditions in a variety of ways; either by using data from weather forecasts or by using an external sensor. For Vaillant controls, this means the control can take this information and modulate the output of the boiler to deliver the most efficient flow rate to reach the desired temperature. This modulation reduces energy use and carbon outputs that reduce bills while increasing the longevity of the boiler.



The VDE institute is an independent and neutral European technical-scientific association that assesses products and services for smart home security.

All of Vaillant's products have been rigorously tested and have met VDE's strict testing criteria for approval by the Institute. You can therefore reset assured that any data used by Vaillant products is protected and secure.



Search for Vaillant on Google Play or the App Store

Traditional controls



timeSWITCH 150

Vaillant traditional mechanical controls have been designed to be easy to use and feel familiar, all whilst automatically offering advanced intelligent functionality (for our combi boilers only).



VRT 50

This easy-to-use digital thermostat has a familiar design that shows the current room temperature. It is more efficient than an analogue thermostat and allows for easy changes to the desired temperature. It uses Vaillant's eBUS technology for enhanced functionality and to ensure compatibility with the timeSWITCH 150.

Note: To comply with Boiler Plus, the timeSWITCH 150 and VRT 50 must be used together.

Key features and benefits

- **Easy to use**
Simple 24 hour timer allows for easy programming, with up to 48 heating on/off times
- **Traditional familiar mechanical timer**
Sliding tappets and a large analogue clock display for easy setting of your time programmes
- **Simple override function**
Manual override does not adjust the time programme when the temperature is in the off and constant on heating modes
- **Quick mode selection**
Heating mode selection dial to enable easy switching between Off, Constant On and Timed modes
- **Time periods as short as 15 minutes**
15 minute time intervals for flexible setting of time programmes
- **Discreet**
Plugs directly into the fascia of the Vaillant boiler without the need for any cable harnesses

Key features and benefits

- **Boiler modulation with our eBUS protocol**
Takes advantage of Vaillant's eBUS protocol to take total control of your Vaillant boiler
- **Enhanced load compensation**
Uses enhanced load compensation to adjust the output of your Vaillant boiler, ensuring it only uses the energy it needs to
- **Service, maintenance and fault indicator**
Appliance service, fault, and maintenance indication is displayed on the screen
- **Clear digital display**
With 0.5°C temperature intervals
- **Wide range of temperatures for your comfort**
The room temperature can be adjusted between 5 - 30°C
- **Simple installation often utilising existing cable**
Two core voltage wired connection for simplicity

Traditional digital controls



timeSWITCH 160

Vaillant digital plug-in controls have been designed to be easy to use. They allow users to choose three heating and hot water time periods over the course of a day. Whilst feeling familiar, they do also offer intelligent functionality via the eBUS language.



VRT 15

Vaillant room controls have been designed to feel familiar and be easy to use. This 230Vac thermostat offers intelligent functionality with Vaillant's eBUS technology.

Note: these traditional controls should always be used together and are suitable for open vent and system boilers only. These controls do not comply with Boiler Plus out of the box.

Key features and benefits

- **Simplistic menu layout**

Easy to set heating and hot water time programs

- **Flexible time programs**

Three heating and three hot water time periods can be set for each week or 24 hour period

- **Quick mode selection**

Quick mode selection easily overrides heating and hot water schedules without making any changes to set programs

- **Service, maintenance and fault indicator**

Appliance service, fault and maintenance indication is displayed on the screen

- **Clear, high contrast backlit display**

Blue backlit display uses proven technology to offer outstanding contrast and low energy use

Key features and benefits

- **Automatic daylight saving**

Automatically adjusts to British summer/winter time

- **Holiday function**

Holiday mode ensures heating is off whilst you're away and ready for your return

- **Discreet plug-in timer**

Plugs directly into the fascia of the Vaillant boiler without the need for any cable harnesses

- **Easily control traditional S and Y plan systems**

Can control either an S or a Y plan system when used with our VR 66 wiring centre

Load compensating control



VRT 350 / 350F

This load compensating control enables seven days of comfort with three temperature settings throughout the day. This control will modulate your boiler to operate as cost efficiently as possible.

Vaillant programmable thermostat controls have been designed to be easy to use and feel familiar whilst automatically offering advanced functionality. The VRT 350 is available in a wireless model (VRT 350f).

The blue backlit screen and plain text display make the VRT 350 easy and clear to understand. Only two push buttons and one rotary dial are needed to select and change data.

Plus, when you go on holiday the VRT 350 and VRT 350f have a holiday set-back function, which reduces the temperature in your property and heats it up before you come back home.

Key features and benefits

- **Boiler modulation with our eBUS protocol**

Takes advantage of Vaillant's eBUS protocol to take total control of your Vaillant boiler

- **Enhanced load compensation**

Enhanced load compensation ensures the boiler modulates so it only ever uses the energy it needs

- **Flexible time programs**

Three heating and hot water periods can be set for each week or 24 hour period

- **Quick mode selection**

This menu allow user to quickly override heating and hot water schedules without affecting set programs

- **Clear, high contrast backlit display**

Blue backlit display offers outstanding contrast and low energy consumption

- **Easy to use intuitive menu layout**

Simple to set heating and hot water programs

- **Fully compatible**

Compatible with Vaillant combi, system and open vent boilers

- **Easily control traditional S and Y plan systems**

Can control either a S or a Y plan system when used with our VR 66/2 wiring centre

- **Service, maintenance and fault indicator**

Appliance service, fault and maintenance indication is displayed on the screen

- **Automatic daylight saving**

Automatically adjusts to British summer/winter time

- **Holiday function**

Ensure heating is turned off for the duration of your holiday, but back-on in time for your return

- **Programs stored in memory permanently**

Holds times and temperature programs permanently, even in the event of power failure

Load compensating control



sensoHOME

The sensoHOME is Vaillant's new control for heating systems that have just one or two zones. It's been designed to be simple to install and use, and operates with Vaillant's proprietary eBUS protocol, ensuring all the components of the system can easily communicate with each other to provide optimum system performance. It's perfect for gas fuelled systems in domestic properties.

Installation of the sensoHOME has been designed to be as easy as possible, with guided commissioning that detects the eBUS components of the system automatically and proposes pre-defined settings.

A simplified interface means that end-users will also find this control more intuitive to use. Time programs can be created in minutes by answering a few questions, and the sensoAPP (available when a sensoNET internet gateway is fitted) makes it easy to use on the go. Weather compensation automatically adjusts the flow rate of the boiler for ultimate modulating efficiency.

The sensoHOME is available in a wireless version (RF) for heating systems that have one heating zone.

Simply search for Vaillant on Google Play or the App Store



Key features and benefits

- **Boiler modulation**
eBUS connection allows the boiler to modulate, ensuring peak performance and optimum efficiency for a Vaillant heating system
- **Intuitive Interface**
The touch interface provides a simplistic method of navigating the control to undertake simple tasks
- **Time program assistant**
Effortlessly set heating programs in minutes using the time program assistant

- **Energy dashboard***
Provides enhanced insight into your heating system performance and energy consumption
- **sensoAPP***
With the sensoNET internet gateway, the sensoAPP can be downloaded and used to manage heating and hot water requirements on the go
- **Weather compensating**
When an outdoor sensor is installed, it will allow the heating system to understand the thermal behaviour in and around the property and adjusts the flow temperatures to ensure optimal efficiency

*sensoNET (VR 921) internet gateway required

Internet connected control



vSMART

vSMART is a wireless heating and hot water control that is managed via an app, allowing for control from a mobile device, anywhere, anytime.

The vSMART room thermostat can be either wall mounted or free-standing, depending on the homeowner's preference and can be fitted in as little as 25 minutes. It uses quick-fit connections from the gateway wires, which are fed straight into the boiler, using our intelligent low voltage eBUS connection which requires easily available 0.75mm, 2 core cable.

Download myVAILLANT Pro today

More details on page 63.

Simply search for Vaillant on Google Play or the App Store



Key features and benefits

- **Boiler modulation**
Vaillant's eBUS protocol ensures the boiler modulates for optimal efficiency and peak performance
- **Internet weather compensation**
Optimises system flow temperatures and efficiency based on the temperature outside your home
- **ErP class VI**
High ErP performance for up to 4% increased efficiency
- **Boiler Plus compatible**
Meets Boiler Plus requirements with ease due to being a smart, weather compensating and modulating control
- **Intelligent self-learning**
Immediately begins to learn the thermal behaviour of the building to better respond to your requirements
- **Android and Apple iOS application**
Easy remote control of heating and hot water via a mobile app

- **Multi-user sharing and multi-home control**
The app allows for multiple users to access one control. You can also use one app to connect to multiple controls, e.g. family home and holiday home
- **Electronic paper display**
Black and white display uses proven electronic paper technology offering outstanding contrast, resulting in crystal clear information. vSMART only uses power when the display is refreshed
- **Holiday function**
Preventing the heating from coming on whilst you are away and putting it back on ready for when you return
- **Multiple personalised usage profiles**
Profiles can be added, providing a completely tailored heating and hot water system
- **Wall mounted or table stand installation**
vSMART is delivered with a wall bracket and a table stand that enables the user to choose the perfect location

System controls



VRC 700 / 700F

The VRC 700 system control allows you to manage all gas, hybrid, or renewable heating systems. The VRC 700 effortlessly ensures your appliances are working to their peak performance and always maintaining optimum efficiency. Available in a wired version (VRC 700) or wireless version (VRC 700f) and with the addition of the VR920, the VRC 700/700f can be controlled via the smartphone app.

The VRC 700 control allows for a single interface that will communicate and control all Vaillant appliances. The VRC 700 will automatically identify and use the most efficient, and therefore most cost effective product at any time. This functionality makes it the perfect controls for hybrid systems.

Simply search for Vaillant on Google Play or the App Store



Key features and benefits

- **Boiler modulation**
eBUS connection allows the boiler to fully modulate to ensure peak performance
- **Multiple heating circuits with domestic hot water control**
The wired VRC 700 control can control up to nine heating circuits and the wireless VRC 700f control can control up to three heating circuits
- **Individual zone control**
Compatible with ambiSENSE thermostatic radiator valves, enabling up to 20 individually controlled rooms
- **Designed with simplicity and familiarity in mind**
Uses a familiar menu structure for ease of use
- **Takes care of all Vaillant equipment automatically**
When used on a hybrid system, it automatically chooses the most efficient and cost effective appliance in the system to deliver the most energy efficient solution
- **Flexible time programs**
Three heating and hot water programs can be set per week or 24 hour period

- **Holiday function**
Turns heating off while you're away and back on for when you return
- **Accepts on/off signals from third party devices**
Can interface with third party underfloor heating controls to provide total system flexibility
- **Clear, high contrast backlit display**
Blue backlit display uses proven technology for super clear information and low energy consumption
- **Programs stored in memory permanently**
Holds times and temperature programs permanently even in the event of a power failure
- **Works with S, S+ and W plan systems**
Can control S, S+ and W plan systems when used with our VR 70 and VR 71 wiring centres
- **Works with Y plan system**
Can control a Y plan system when used with our VR 66/2 wiring centre
- **Fully compatible**
Compatible with Vaillant combination, system and open vent boilers

System controls



sensoCOMFORT

The sensoCOMFORT is Vaillant's new control for multi-zone heating systems. It's been designed to be simple to install and use, and operates with Vaillant's proprietary eBUS protocol. This ensures all the components of the system can easily communicate with each other to provide optimum system performance. It's perfect for multi-zone gas-fuelled systems, and hybrid, or renewable installations.

The sensoCOMFORT has been designed to be simple to install, with guided commissioning that detects all the components of a system and proposed pre-defined settings.

A simplified interface means that end-users will also find this control more intuitive to use. Time programs can be created in minutes by answering a few questions, and the sensoAPP (available when a sensoNET internet gateway is fitted) makes it easy to use on the go.

End-users will benefit from the energy dashboard feature, which provides valuable insights into energy consumption over a two-year period. This data will include an overview on renewable gain when a flexoTHERM heat pump and/or solar thermal unit is fitted as part of the heating system.

The sensoCOMFORT is available in a wireless version (RF) that can control up to three heating zones.

Simply search for Vaillant on Google Play or the App Store



Key features and benefits

- **Boiler modulation**
eBUS connection allows the boiler to modulate, ensuring peak performance and optimum efficiency for a Vaillant heating system
- **Weather compensating**
sensoCOMFORT comes with an outdoor sensor that provides an understanding of the thermal behaviour in and around the property and adjusts the flow temperatures to ensure optimal efficiency
- **Intuitive Interface**
The touchscreen interface provides a simplistic method of navigating the control to undertake simple tasks

- **Energy dashboard**
Provides enhanced insight into your heating system performance and energy consumption
- **Multiple heating circuits with domestic hot water control**
The wired sensoCOMFORT control can control up to five heating circuits. The wireless version can control up to three zones
- **Time program assistant**
Effortlessly set heating programs within minutes using the time program assistant
- **sensoAPP***
With the sensoNET internet gateway, the sensoAPP can be used to manage heating and hot water requirements on the go

*sensoNET (VR 921) internet gateway required

Connected thermostatic radiator valve



ambiSENSE

ambiSENSE is the name of Vaillant's intelligent thermostatic radiator valves (TRVs). They fit onto radiators to control the temperature in the most precise way possible.

Controlled via an app, ambiSENSE TRVs allow users to create personalised heating schedules to ensure each room has its own temperature and timing programs. Up to 20 zones can be created.

ambiSENSE valves save energy as well as creating perfect comfort for each individual room.

Simply search for Vaillant on Google Play or the App Store



Key features and benefits

- **Refined comfort**
ambiSENSE works in conjunction with the VRC 700 and sensoCOMFORT system controls to meet the personalised requirements of everyone in the home
- **Control up to 20 valves**
Each controller can work with up to 20 valves. Each valve head has its own signal booster, so distance from the controller is never a problem
- **Control your system on the go**
Compatible with apps that mean you can control your heating from your mobile device to boost or delay your heating if required
- **Weather compensating**
Automatically compensates for the weather outside using weather data received from the control
- **Easy to install**
It's simple to replace standard TRVs with ambiSENSE smart valves. Full instructions are provided
- **Up to seven devices per profile**
Up to six valve heads and one thermostat can be fitted per room. They will automatically sync with each other
- **Easily identify which room you want to control**
Replace the symbol for the zone with a snapshot of that room for increased personalisation and clarity
- **Detects open windows**
If a window is open, the ambiSENSE valve head will detect this and stop trying to heat the room, saving you energy
- **Manually alter the temperature**
Turn the dial on the valve heads to directly alter the temperature for an hour without disrupting your time program
- **Child lock**
Prevent unscheduled temperature changes by activating the child lock through the app
- **Clear digital display**
Digital screen on the valve heads displaying the set temperature

myVAILLANT Pro



Download
myVAILLANT Pro
today



Vaillant introduces myVAILLANT Pro to help our customers help their customers

Vaillant introduced its eBUS communication technology into its products in 2006. This enables Vaillant appliances to talk to each other and offers data on the performance of the heating system and its components.

This technology now means that Vaillant can support installers to offer their customers extra levels of service and support - using myVAILLANT Pro.

The solution enables installers to remotely monitor their customer boiler installations, with access to detailed performance data, fault code history and offer diagnostic insights - all at the click of a button.

Download myVAILLANT Pro today

Currently only compatible with Vaillant's vSMART connected control.

Benefits at a glance

Improved service efficiency

Be notified immediately of a fault on a customer's appliance, with insights on how to rectify, so you can plan ahead and have an even more efficient first visit

Diagnostic insights

Data driven insights on failures to aid repairs and spare part identification

Customer management

Easily manage customers in the secure customer database which gives quick visibility of appliance model and serial number

Latest appliance documents

Installation, user instructions with exploded views, and wiring diagrams available

Plannable business

Schedule multiple service and repair visits more efficiently using the failure and spare part insights provided

Intelligent repairs

Improve first-time fix rates by knowing what parts you need before you arrive

Detailed fault and status history and information

Time and date stamped service and fault history for each connected appliance and the latest fault information available for all supported appliances

Installation and manufacturing date

Complete transparency of the appliance production and installation

Remotely monitor appliance and thermostat

Easily review appliance data points whilst on the move and manage customer's time programs set on their thermostat

Get started with myVAILLANT Pro in three easy steps

1. Download the app

The app can be easily accessed directly through the myVAILLANT Pro website or by downloading the iOS or Android app.

2. Sign-in with Advance

You need an active Vaillant Advance account to access myVAILLANT Pro. You can create one via the links found on the app, the myVAILLANT Pro website, or on the Advance website or app.

3. Get started

Set-up is complete! Start adding customers and providing peace of mind with myVAILLANT Pro.



Security

Vaillant is proud in ensuring myVAILLANT Pro is secured for today and tomorrow.

All Vaillant products are tested and approved by the VDE Institute, an independent and neutral European technical-scientific association that tests and certifies electro technical devices, components, and systems. Products carrying the VDE mark have been independently assessed against international standards and legal protection requirements.

You can therefore rest assured that Vaillant products are secured and protected to the highest level.

System water



Why is clean system water so important?

Due to the variety of issues that can be caused in the boiler by unclean water in the system, the Government has legislated that any new or replacement heating system must be chemically cleaned, and the filled system has to be treated with a chemical inhibitor to prevent corrosion and the build-up of scale. The British Standard that outlines the requirements of the Domestic Building Services Compliance Guide or the Domestic Chemical Water Treatment Manufacturers Association are free to download.

There are several measures that should be implemented to test and treat system water so that it doesn't impact on the performance of the boiler.

Turbidity

The amount of Total Diluted Solids (TDS) in the water can be tested with a turbidity tube. A level of <200ppm indicates minor contamination that can be treated with chemicals. If the reading is >200ppm, a power flush is recommended.

Is the water hard or soft?

Water hardness sticks are easy to use. Where hard water is identified, a scale prevention measure is required. Vaillant recommends the use of a magnetic filter.

pH

If the system water is too acidic, the metals in the system are in danger of corroding. If the water is too alkaline, then there is a danger of electrolysis. It's therefore important to ensure the water stays between 6.5 and 8.5. It's easy to get a reading using pH sticks or an electronic reader.

It's important to carry out annual inspections as poor water quality can void a guarantee or warranty. This should be done during the annual service when checking the pressure in the expansion vessel, as the drained water can be easily tested and will indicate the level of inhibitor in the system.

More detailed information is available on our website



Water cleanliness



Galvanic corrosion

Water filters - Boiler Protection Kit



Boiler Protection Kit

Today's highly energy-efficient heating and cooling systems can only offer optimal performance with dirt-free water.

The unique magnetic field booster technology guarantees unprecedented fast, optimal dirt separation. Even the smallest magnetite particles are removed, maximising system performance as well as protecting costly system components.

Thanks to the ingenious design, collected dirt can be removed quickly and easily.

Key features and benefits

- **Small particle removal**
Very small particles, from $5\mu\text{m}$ (= 0.005 mm) and up are separated and removed
- **Valveless design**
No shut-off valves or bypass required
- **Constant low pressure drop**
Maximising system performance
- **Low maintenance**
Maintenance only takes a few seconds and is not a dirty job compared to a filter solution
- **Flexible**
22mm and 28mm connection diameters available.
22 mm version suitable for boilers with heating output up to 27kW. 28 mm version suitable for boilers with heating output of 28 to 45kW



More detailed information is available on our website

Advance Boiler Protection Kit



Advance Boiler Protection Kit

The high-quality Advance Boiler Protection Kit helps extend the life of boilers and provides more flexibility for set-ups.

Our UK engineers have designed the filter so that it can fit horizontally onto the pipework, close to the bottom of the boiler in tight spaces, making it a very discreet solution that protects the boiler and keeps it functioning more efficiently, for longer.

The Advance Boiler Protection Kit is supplied with a 22mm isolation valve for simple and quick drain-down of the filter for maintenance and cleaning. It has a maximum operating pressure of three bar and is not available for our 48 and 64kW boilers. Patent pending UK 2009327.4.



More detailed information is available on our website

Key features and benefits

- **Horizontal fitting**
Designed to be sited horizontally for a discreet, space saving fit
- **High-quality brass design**
The body of the filter has a superior brass construction
- **Compact design**
Barely visible when installed, offering flexibility for siting
- **Quick servicing**
Easy to dismantle, so the magnet shield can be easily removed for quicker cleaning
- **800 micron stainless steel non-ferrous filter**
Hard wearing stainless steel mesh that collects non-magnetic debris and blocks sludge from entering the boiler
- **Limitless installation orientations**
Suitable for boilers located in any situation

- **Compatible with water and water/glycol mixes**
Perfect for boilers installed in cold situations where glycol has been added to protect from freezing
- **500 ml volume capacity**
Allows for easy dosing of chemicals
- **Advanced magnetizing process**
Exerts its magnetic power in a wider region, even when full, for fully optimised filtration efficiency that averages over 80%, even when the magnet is fully covered
- **Standard 3/4" drain point connection**
Can connect to a standard hose, so the drain point can also be used for dosing. The unique sealing ring and swivel head allows it to rotate without leaking for easier serviceability
- **Maximum operating temperature 90°C**
Ideal for modern systems as well as older, high temperature systems

Domestic hot water cylinders



Overview

Performance and reliability are what Vaillant is all about. That's why our products have been expertly designed and engineered to work to their full potential together. Working in harmony with all the Vaillant domestic boilers, the uniSTOR cylinder range uses state of the art, best in class insulation that provides ultimate efficiency.

Vaillant cylinders are tested in accordance with all industry standards. In addition, Vaillant fully supports and complies with the additional requirements of the Hot Water Association and the rigorous auditing process that ensures the highest quality standards are maintained.

Key features and benefits

- **Extended cylinder range**
Easy to select right product required for the system
- **Slimline cylinders available**
Perfect for smaller spaces
- **Pre-plumbed cylinders**
For faster installation and time and money savings
- **Improved insulation**
Best in class ErP rating and very low heat loss
- **Metal outer jacket**
High quality protection for the cylinder that makes it easier to keep clean
- **Controls mounting plate**
For easy location of controls (pre-plumbed only)
- **In-line front connections**
For easy and neat installation
- **Adjustable feet (excluding slimline models)**
For easy installation on uneven ground
- **Hidden cable duct**
Easy and neat wiring of cylinder
- **Unvented kit and expansion vessel supplied with product**
(supplied with product)
No additional cost to meet G3 requirements
- **25-year guarantee**
The shells of the cylinders have a 25-year guarantee for total peace of mind
- **Flexible**
Designed to work perfectly with Vaillant system and open vent boilers as well as heat pumps. Suitable for retro-fitting



uniSTOR slim-line pre-plumbed cylinder

Technical data	Unit of measure	uniSTOR slimline pre-plumbed	
Model		120	150
Article number		0010019209	0010019210
Maximum height	mm	1427	1642
Diameter	mm	435	435
Unvented kit	l	12	12
ErP rating	A+ - F	C	C
Heat loss	kW / 24hrs	1.68	1.80
Coil output	kW	16.4	16.1
Coil size		0.65	0.65
Primary flow rate	l/h	900	900
Re-heat (70%)	mins	15.2	18.4
Heat up 15 to 60C	mins	21.7	26.3
Actual water capacity	l	121	141
Weight empty	kg	49.5	53.6
Weight full	kg	171	195



uniSTOR pre-plumbed cylinder

Technical data	Unit of measure	uniSTOR pre-plumbed			
Model		180	200	250	300
Article number		0010019211	0010019212	0010019213	0010019214
Maximum height	mm	1165	1265	1535	1745
Diameter	mm	595	595	595	595
Unvented kit	l	18	18	25	25
ErP rating	A+ - F	B	B	B	B
Heat loss	kW / 24hrs	1.11	1.22	1.41	1.59
Coil output	kW	17.1	16.9	16.6	16.5
Coil size		0.80	0.80	0.80	0.80
Primary flow rate	l/h	900	900	900	900
Re-heat (70%)	mins	20.7	22.1	30.3	34.0
Heat up 15 to 60C	mins	29.6	31.6	43.3	48.5
Actual water capacity	l	175	194	245	284
Weight empty	kg	59.0	61.2	70.9	76.0
Weight full	kg	234	255	316	360



uniSTOR standard cylinder

Technical data	Unit of measure	uniSTOR standard					
		120	150	180	200	250	300
Model		120	150	180	200	250	300
Article number		0020235265	0020235266	0020235267	0020235268	0020235269	0020235270
Maximum height	mm	840	1000	1165	1265	1535	1745
Diameter	mm	595	595	595	595	595	595
Un-vented kit	l	12	12	18	18	25	25
ErP rating	A+ - F	A	A	B	B	B	B
Heat loss	kW / 24hrs	0.83	1.00	1.11	1.22	1.41	1.59
Coil output	kW	15.8	17.2	17.1	16.9	16.6	16.5
Coil size		0.69	0.69	0.80	0.80	0.80	0.80
Primary flow rate	l/h	900	900	900	900	900	900
Re-heat (70%)	mins	14.3	18.6	20.7	22.1	30.3	34.0
Heat up 15 to 60C	mins	20.4	26.6	29.6	31.6	43.3	48.5
Actual water capacity	l	115	145	176	194	245	284
Weight empty	kg	33.0	36.0	40.0	42.0	52.0	56.0
Weight full	kg	148	181	216	236	297	340

Industry leading training for industry leading engineers



Our training team provides industry brilliance with its tailored training courses, striving to keep you one step ahead of the ever-evolving heating and hot water technologies and industry regulations.

Due to the dynamic situation in 2020 we are running most of our courses online, with hands-on sessions in our Centres of Excellence whenever possible. For the most up to date information on the courses that are available, please visit our website at www.vaillant.co.uk

Service and spares support



Spares and support, year after year

Vaillant is committed to responsible spares provision and provides spares for a minimum of 15 years after production ceases. We have a nationwide network of genuine spares stockists and a dedicated spare parts team to help you identify the parts you require.

Vaillant has even developed an app that helps identify spare parts to make ordering easier.

sparesCHECK app

- ✓ Trade only
- ✓ Online & offline
- ✓ Exploded device views
- ✓ Over 4,000 pictures
- ✓ Serial number scanning
- ✓ Part "where used"



Simply search for Vaillant on Google Play or the App Store

Service you can count on

At Vaillant UK, we invest as much of our resources into our service and support as we do in creating our outstanding heating solutions. So you can rest assured that when you choose a Vaillant product, you will be supported by the best service in the industry.

Vaillant has specialist teams available to support installers and end-users with all enquiries. We pride ourselves on the efficiency of our service departments, supported by online tools that allow our customers to book appointments for our services for added convenience.

Vaillant has over 250 service engineers. This includes the largest specialist fleet of renewable and commercial systems engineers in the UK.

With phone operators available 364 days a year, service and support from Vaillant UK is never far away.

Supporting your business



Free extended guarantees

Product	Out the box Guarantee	Free Advance Guarantee
ecoTEC exclusive with Green iQ	5 years	10 years*
ecoTEC plus	5 years	10 years**
ecoTEC pro	2 years	7 years
ecoTEC plus 48/64	5 years	N/A
ecoFIT pure	2 years	10 years*
aroTHERM	2 years	5 years

*When fitted with a boiler protection kit

**When fitted with a boiler protection kit, excludes 48 and 64kW light commercial boilers

Training

Visit your local Vaillant Centre of Excellence for industry leading training on our products and receive 200 credits for attending. To find out more information and what courses are available, give our Training team a call on **0345 601 8885** or email on training@vaillant.co.uk or contact your local Area Sales Manager.

Homeowner leads

We'll send you leads from local homeowners from our 'Find an Installer' tool.

Help at your fingertips

Pick up our handy quick start guide to discover how quick and simple it is to register our products through the Advance app.

Download the Advance app and start boosting your business today. Sign up at vaillant-advance.co.uk

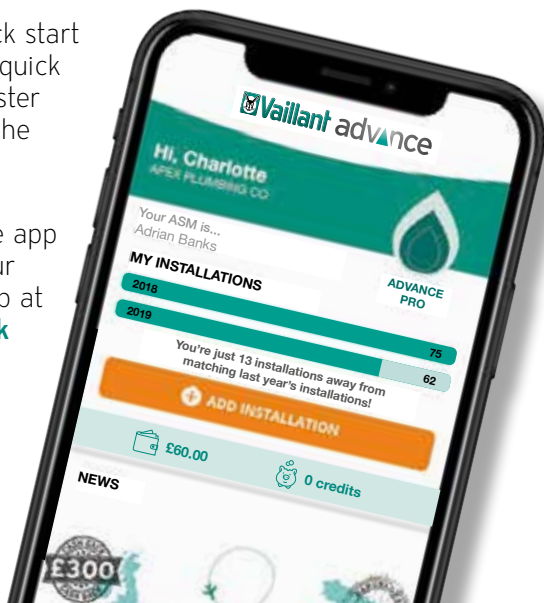

Rewarding your loyalty

Ways to earn cash and credits

- Register Vaillant products on Advance
- Use #Advance on your Twitter posts
- Complete our training
- Attend an event
- Special personalised offers

Our catalogues

You can get me, branded workwear, work equipment and other great stuff on the credit catalogue.



Your cashback can be spent on discounted tools, vouchers or withdrawn as a business cheque.

Advance trips

All members can take part in our Advance To Go and Advance To Snow incentives. Anyone who participates has the opportunity to join us on an exclusive, all-expenses paid trip to some of Europe's top destinations just by installing and registering our products.



What can you do on the Advance app?



Register Vaillant products



Free Gas Safe registrations



Access all our manuals and literature



Special offers

Order numbers

Article description	Article code
Advance Boiler Protection Kit (22mm)	0010035819
Boiler protection kit (22mm)	0020278309
Boiler protection kit (28mm)	0020278310
Combi boilers	
ecoTEC exclusive 835	0010017064
ecoTEC exclusive 843	0010017065
ecoTEC plus 825	0010021823
ecoTEC plus 832	0010021824
ecoTEC plus 832 LPG	0010021825
ecoTEC plus 835	0010021822
ecoTEC plus 838	0010021826
ecoTEC plus 938	0010021827
ecoTEC pro 24	0010021836
ecoTEC pro 28	0010021837
ecoTEC pro 28 LPG	0010021838
ecoTEC pro 30	0010016538
ecoFIT pure 825	0010020389
ecoFIT pure 830	0010020390
ecoFIT pure 835	0010020391
System boilers	
ecoTEC exclusive 627	0010017063
ecoTEC plus 612	0010021828
ecoTEC plus 615	0010021829
ecoTEC plus 618	0010021830
ecoTEC plus 618 LPG	0010021831
ecoTEC plus 624	0010021832
ecoTEC plus 630	0010021833
ecoTEC plus 630 LPG	0010021834
ecoTEC plus 637	0010021835
ecoTEC 48	0010021520
ecoTEC 64	0010021521
ecoFIT pure 612	0010020395
ecoFIT pure 615	0010020396
ecoFIT pure 618	0010020397
ecoFIT pure 625	0010020398
ecoFIT pure 630	0010020399
Open vent boilers	
ecoTEC plus 412	0010021220
ecoTEC plus 415	0010021221
ecoTEC plus 418	0010021222
ecoTEC plus 424	0010021223
ecoTEC plus 424 LPG	0020231355
ecoTEC plus 430	0010021224
ecoTEC plus 435	0010015674
ecoFIT pure 412	0010020400
ecoFIT pure 415	0010020401
ecoFIT pure 418	0010020402
ecoFIT pure 425	0010020403
ecoFIT pure 430	0010020404
ecoFIT pure 435	0010020405
Controls	
vSMART combi Pk	0020223154
vSMART System/OVent Pk	0020223158
VRT 350	0020124475
VRT 350F	0020124482
VRT 15	306777
VRT 50	0020018265
timeSWITCH 150	0020116882
timeSWITCH 160	0020124498
Wireless VRC 700F	0020259829
Wired VRC 700	0020236291
VR 920	0020252923
ambiSENSE starter Pk	0020242485
ambiSENSE VR50 GB	0020242487
ambiSENSE VR51	0020247923
Wired VRC 700 1 Radiator zone & DHW	0020236292
Wired VRC 700 2 Radiator zone & DHW	0020236293
Wired VRC 700 3 Radiator zone & DHW	0020236294
Wireless VRC 700 1 Radiator zone & DHW	0020259830
Wireless VRC 700 2 Radiator zone & DHW	0020259831
Wireless VRC 700 3 Radiator zone & DHW	0020259832
sensoCOMFORT 1 Radiator zone & DHW	0010036821
sensoCOMFORT 2 Radiator zone & DHW	0010036822
sensoCOMFORT 3 Radiator zone & DHW	0010036823
sensoCOMFORT 4 Radiator zone & DHW	0010036824
sensoCOMFORT 5 Radiator zone & DHW	0010036825
sensoCOMFORT RF 1 Radiator zone & DHW	0010036826
sensoCOMFORT RF 2 Radiator zone & DHW	0010036827
sensoCOMFORT RF 3 Radiator zone & DHW	0010036828
sensoHOME	0020260951
sensoHOME RF	0020260961
Cylinders	
Slim-line pre-plumbed	
uniSTOR 120	0010019209
uniSTOR 150	0010019210
Pre-plumbed	
uniSTOR 180	0010019211
uniSTOR 200	0010019212
uniSTOR 250	0010019213
uniSTOR 300	0010019214
Standard	
uniSTOR 120	0020235265
uniSTOR 150	0020235266
uniSTOR 180	0020235267
uniSTOR 200	0020235268
uniSTOR 250	0020235269
uniSTOR 300	0020235270
Flues and accessories	
Bends 45° (2 off) DN60/100	303911
Elbow 87° DN60/100	303910
Extension 1.0m DN60/100	303903
Extension 2.0m DN60/100	303905
Extension 4.0m DN60/100	0020138174
Extension 0.5m DN 60/100	303902
Extension 0.5m DN 80/125	303202
Fixing clamp (5 off)	303821
Flue support clips (5 off)	303935
Flue terminal kit (black)	0020219537
Horizontal flue kit 1.7m	0020219519
Horizontal flue kit DN60/100	0020219517
Horizontal telescopic flue kit DN60/100	0020219518
Pitched roof tile flexible	303980
Pitched weather collar	009076
Plume deflector kit (black)	0020219533
Plume deflector kit (white)	0020219534
Pipe cover plate (large)	0020237908
Pipe cover plate (small)	0020237909
Rear telescopic flue kit	0020228140
Roof terminal (black)	0020223472
Ridge tile terminal	303982
Sliding sleeve DN60/100	303915
Telescopic offset flue DN60/100	303919
Variable termination kit (black)	0020219529
Variable termination kit (white)	0020219530
VTK elbow 45 deg (2 off) (black)	0020219551
VTK elbow 45 deg (2 off) (white)	0020219552
VTK elbow 87 deg (black)	0020219543
VTK elbow 87 deg (white)	0020219544
Spacing frame (ecoFIT pure c&s only)	0020229924
Spacing frame (ecoTEC plus / pro c&s only)	308650
ecoLEVEL condensate pump	0020030797
Upward piping kit	0020237907

Contacts

Sales enquires

Vaillant sells its products through plumbing and heating merchants in the UK. For further information, contact your local Vaillant sales representative.

Phone: **0345 602 2922**

Renewables

For renewable products aftersales service and commissioning.

Phone: **0345 602 0262**

Email: aftersales@vaillant.co.uk

General enquiries

If you are unsure of who you need to speak to or you have a general enquiry, our friendly reception staff will happily point you in the right direction.

Phone: **0345 602 2922**

Training

For information on training centres and courses in your area.

Phone: **0345 601 8885**

Email: training@vaillant.co.uk

Technical enquiries

If you have a technical query, you can contact us by phone or email.

Phone: **0344 693 3133**

Email: technical@vaillant.co.uk

Spares enquiries

If you need helping finding a spare part, you can download our app from the appStore or Google Play.

Phone: **01773 596 615**

Option 1: Vaillant stock availability

Option 2: If you require a part number

Commercial

For aftersales and technical support for larger output boilers.

Phone: **0330 102 8570**

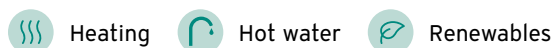

Vaillant Group UK Ltd.

Nottingham Road, Belper, Derbyshire DE56 1JT

Telephone 0345 602 2922

www.vaillant.co.uk/for-installers

info@vaillant.co.uk



VALBROB2BDOM0921