

ASSEMBLE TOP SEAT, VERTICAL AND COVER MIRAGE FRAME (MIRAGE FRAME)

a) PRE-ASSEMBLING VERTICALS

Put Cover Bracket as shown in the figure.

Put Resin Upper Joint as shown in the figure, tighten up #12 Sheet Metal Screws.

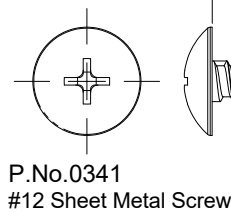
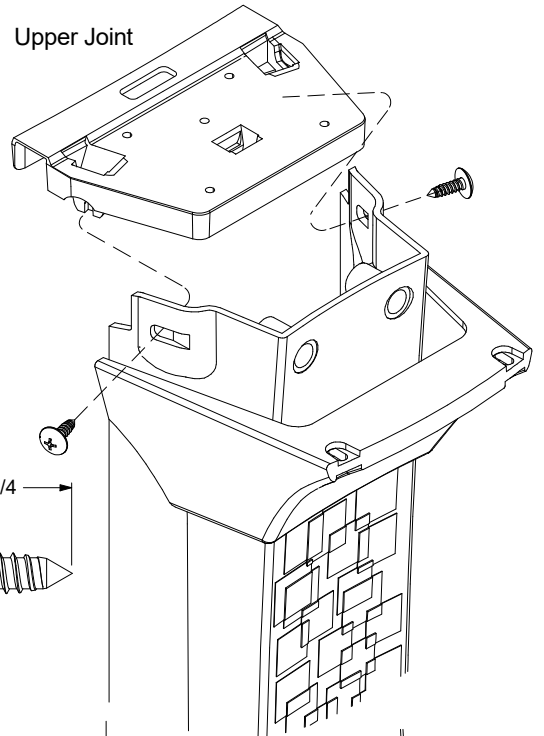
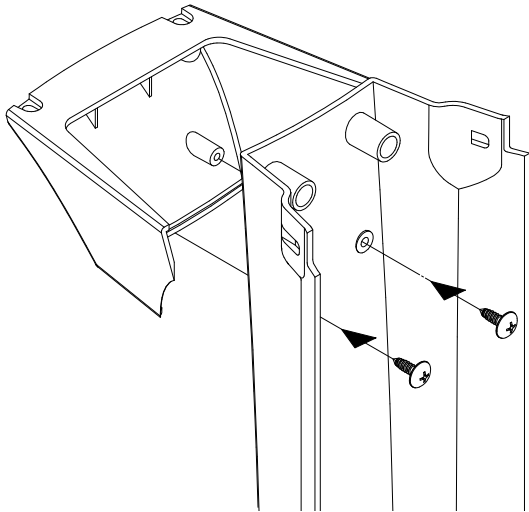

b) INSTALLING VERTICALS

Hook Assembled Resin Upper Joint over the top rail. Secure the bottom of vertical to Resin Lower Joint by #12 Sheet Metal Screws. Continue installing verticals in this manner all around the pool.

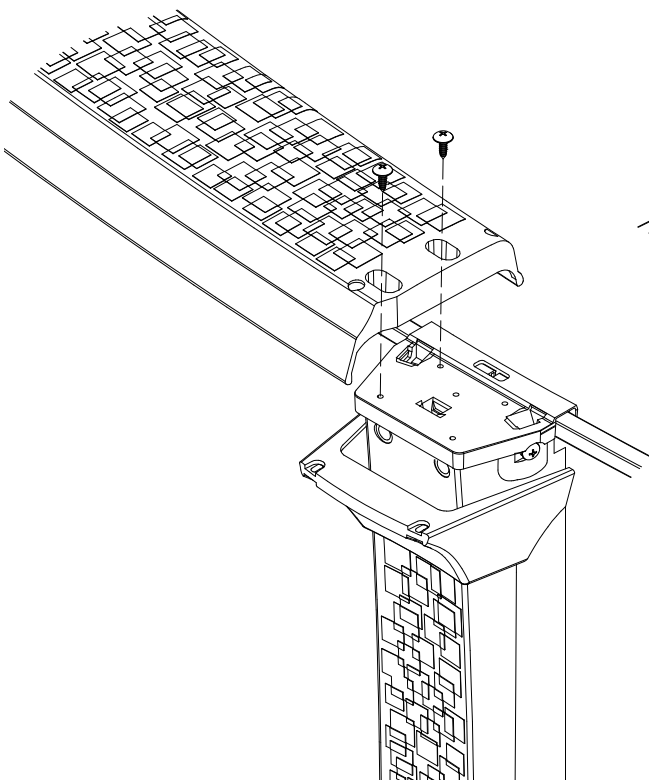
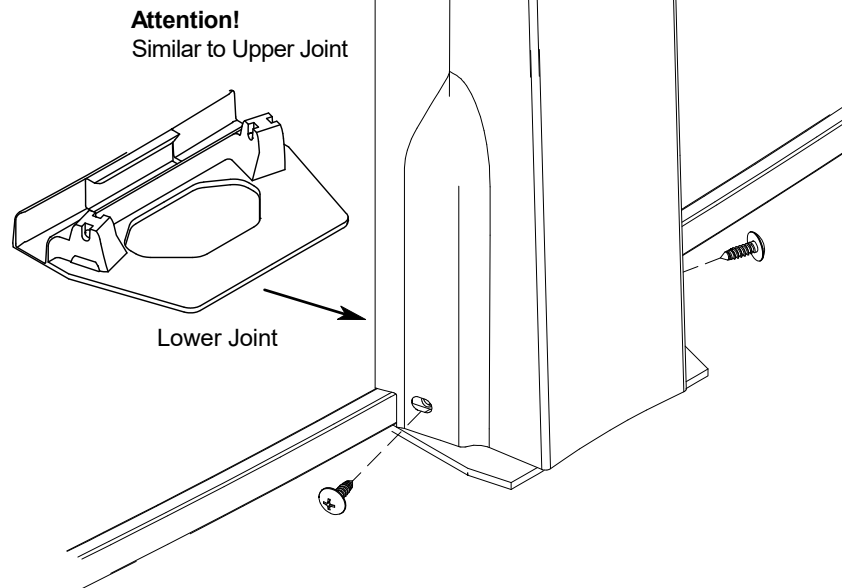

c) INSTALLING TOP SEATS

Place each of the top seat over the upper joints and secure with #12 Sheet Metal Screws.

Install all of top seat in this way around entire pool. Top seat are installed between verticals. Each end of top seat rest on upper joint and attached to it.

It may be necessary to move the complete verticals slightly to left or right to accommodate the top seat.

Do this carefully as not disturb the earth mound. Check all screws to be sure they are tight.

d) INSTALLING SEAT COVERS

Attach seat cover by placing it from inside of pool in right position as shown in the figure.

Put seat cover and cover bracket together, Insert #12 Sheet Metal Screw from cover bracket to seat cover, and tighten it up.

Put #12 Sheet Metal Screw to seat cover and tighten it up. Put seat cover cap on top of side seat cover.

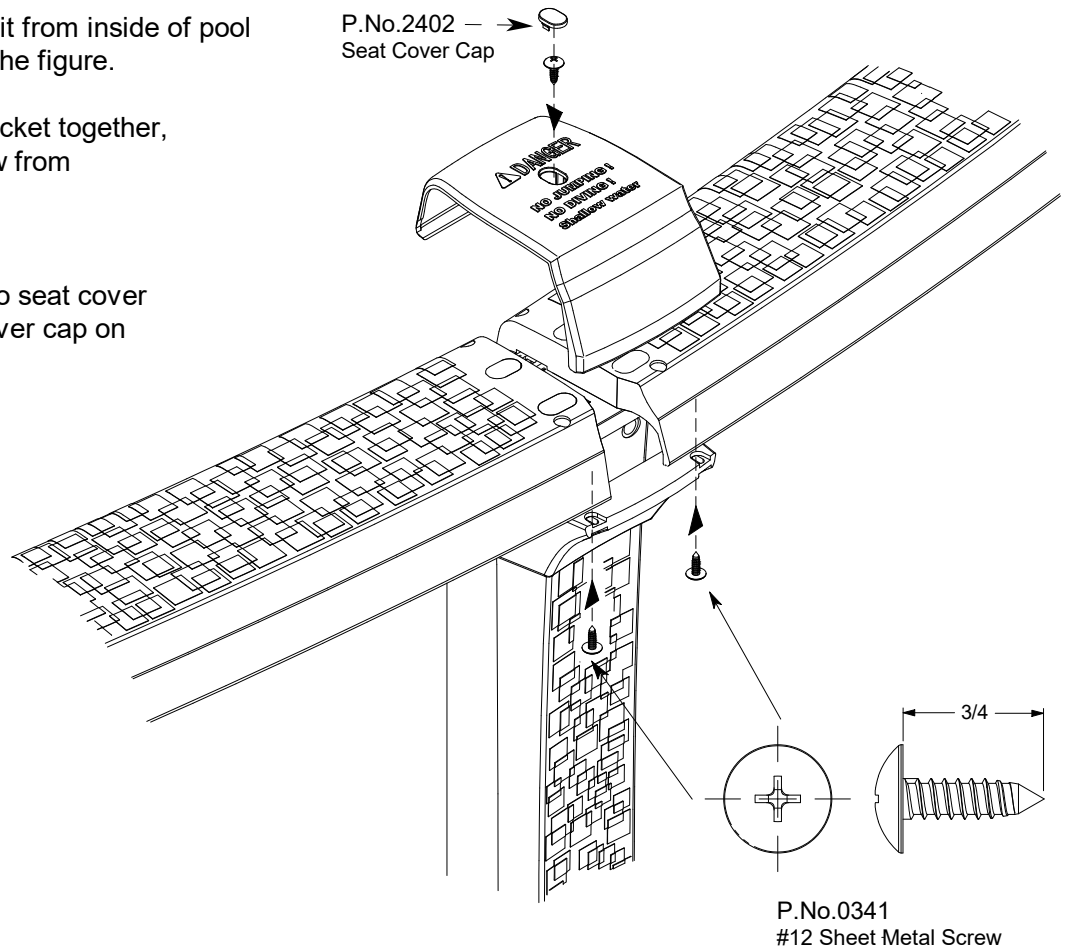

FOR OVAL POOL ONLY

e) INSTALLING OVAL SIDE TOP SEAT AND SIDE SEAT COVERS

Use #12 Sheet Metal Screw to install oval side top seats on top of resin side upper joint P. No. 3177.

Attach side seat cover as shown in the figure.

Put seat cover cap on top of side seat cover.

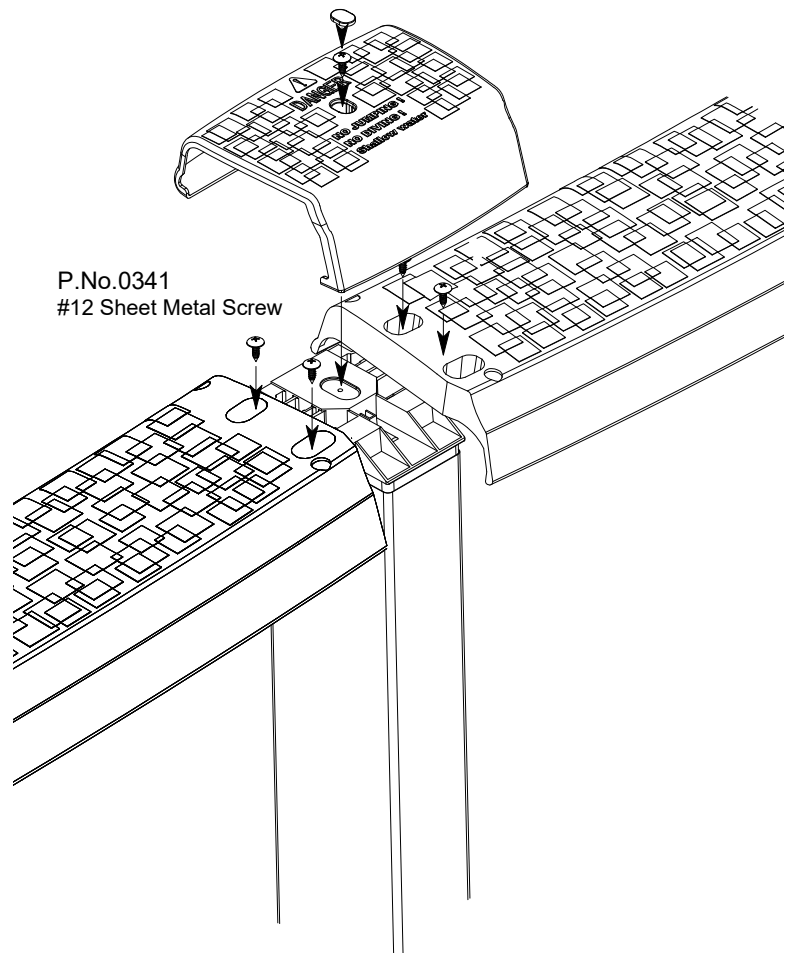

! DANGER

ALL THESE POOLS ARE DESIGNED FOR SWIMMING ONLY.
THEY MUST NOT BE USED FOR JUMPING OR DIVING.

DO NOT JUMP
DO NOT DIVE

PERMANENT INJURY OR DEATH CAN RESULT.

ASSEMBLAGE DE LA MARGELLE ET POTEAUX DE STRUCTURE MIRAGE (MIRAGE FRAME)

a) PRÉ-ASSEMBLAGE DES POTEAUX

Installer les supports de couvre-joints tel qu'illustré.

Installer la plaque du haut en résine tel qu'illustré.

Visser et bien serrer les visses métalliques #12.

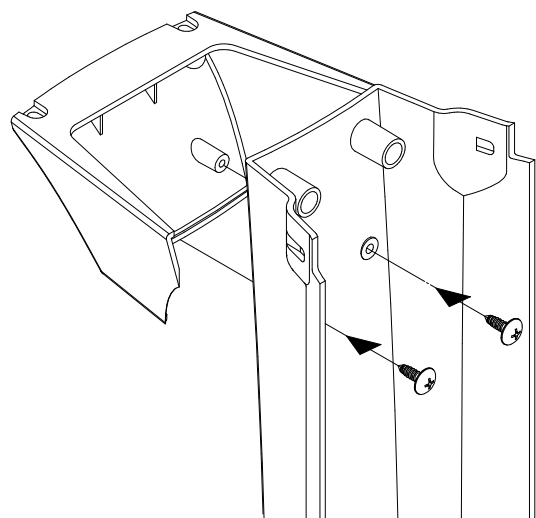

Plaque du haut

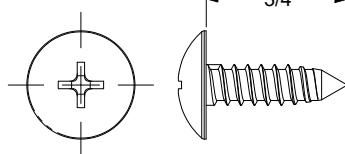

P.No.0341
Visse métallique #12

b) INSTALLATION DES POTEAUX

Installer le couvre joint par-dessus le joint de margelles. Assembler la plaque du bas en résine au bas du poteau. Visser et bien serrer les visses métalliques #12. Répéter l'opération pour tous les poteaux autour de la piscine.

Attention!

Similaire à Plaque du haut

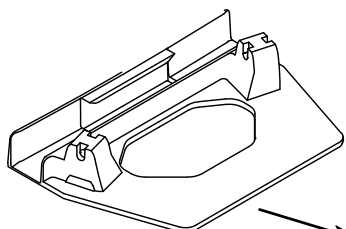

Plaque du bas

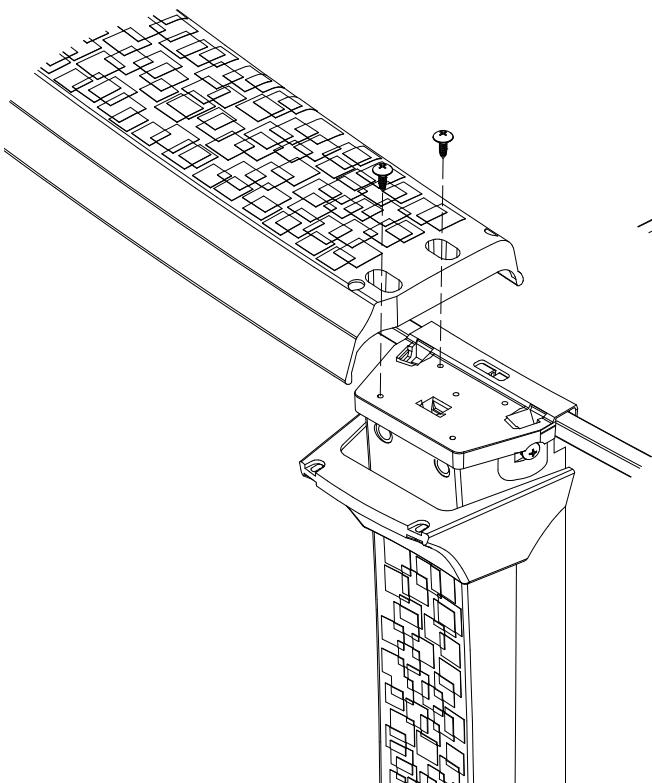

c) INSTALLATION DES MARGELLES

Positionner chaque margelle sur les plaques du haut et visser les visses métalliques #12.

Installer toutes les margelles de cette manière autour de la piscine, entre chaque poteau. Le haut des poteaux peuvent être légèrement bougés pour assurer une bonne installation des margelles.

Faire attention de ne pas bouger le bas des poteaux et les rails du bas durant l'opération.

Vérifier chaque visse métallique #12 afin de s'assurer qu'elles sont bien serrées.

d) INSTALLATION DES COUVRE-JOINTS

Fixer le couvre-joint de l'intérieur de la piscine dans la bonne position tel qu'illustré.

Assembler le couvre-joint et le support, insérer la visse métallique #12 à partir du support vers le couvre-joint et serrer.

Utiliser les visses métalliques #12 pour fixer les couvre-joints par-dessus les margelles, dans les plaques du haut. Installer cache vis plastique de couvre-joints.

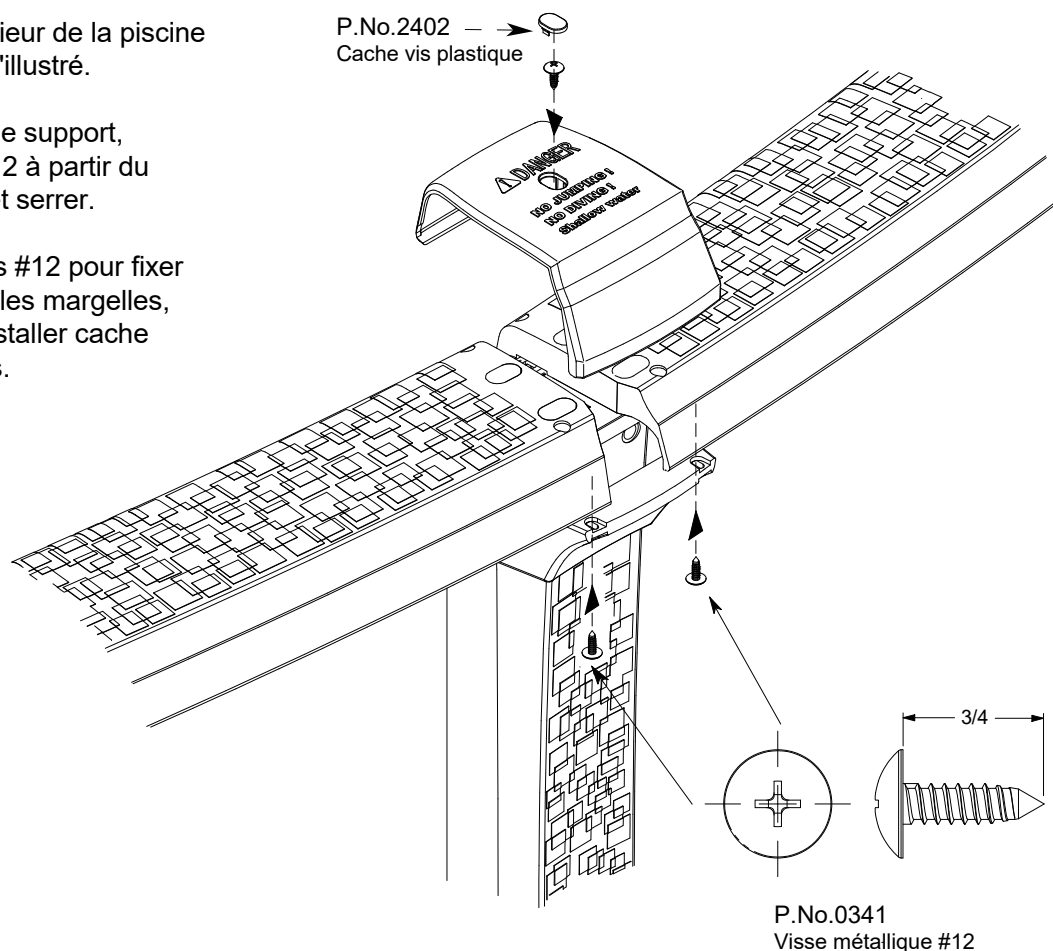

POUR PISCINES OVALES SEULEMENT

e) INSTALLATION DES COUVRE-JOINTS DE CÔTÉ SUR LES PISCINES OVALES.

Utiliser les visses métalliques #12 pour fixer les margelles sur les plaques du haut. P.No.3177.

Fixer le couvre-joint tel qu'illustré.

Installer cache vis plastique de couvre-joints.

