

PHP-WF-004 V1.0 EN

PENTHOUSE™
PAWS

Automatic Pet Water Fountain



Before using the product, please read this manual thoroughly and retain it for future reference.



Contents

Safety Precautions	1
Product Overview	3
How To Use	5
Care Instructions	8
How To Clean The Pump	8
How To Bind App	9
Troubleshooting	13
Specifications	13
Warranty	14

Safety Precautions

Warning!

- Dispose of all packaging materials properly. Keep the polybags away from children and pets as these bags could cause suffocation.
- Do NOT allow children to play with, in or around the pet water fountain.
- To avoid injury, please keep close supervision when the appliance is used near children.
- Do NOT use the water fountain with pets not able to reach the water tray or with any physical disability.
- Do NOT place any foreign object in the water tank.
- Do NOT disassemble the pet fountain other than components as instructed in this User Manual.
- Do NOT use the pet fountain for anything other than its intended use.
- Only use attachments recommended or sold by the manufacturer. The use of attachments not recommended or sold by the manufacturer may cause an unsafe condition. Do NOT modify the pet fountain.
- Do NOT operate any appliance if the unit is malfunctioning or has been damaged. Do not attempt repairs on the device yourself.
- Contact our customer service immediately for further instructions.
- Be sure to disconnect the power supply for safety when the appliance is not in use.
- Please disconnect the power supply before maintaining and cleaning the machine.
- Always unplug the appliance when not in use; or before putting on or taking off parts and before cleaning.

- The power adapter and wire plug must not be flooded during cleaning.
- This product is for indoor use only.
- This product is not allowed to run without water.
- Read and observe all important notices listed on the pet water fountain and the packaging.
- Never pull the electrical power cord to remove the plug from the wall outlet. If the plug of this device gets wet, turn off the electricity of that wall outlet. Do NOT attempt to unplug.
- Check the device after installation. Do NOT plug in if there is water on the contact points or plug.
- To avoid tripping, always position the power cord out of the way of foot traffic.
- Do not use the appliance in the bathroom.
- Change the filter every 2 weeks or when the flow rate has noticeably reduced. For two or more cats, you may need to replace the filters more regularly if it becomes blocked.

Caution

- Do NOT allow pets to chew on or swallow any parts. If you are concerned about the power cord, purchase a cord conduit (a hard-plastic protector) at any hardware store to protect the power cord.
- If an extension cord is necessary, one unit with a proper rating should be used.
- Do NOT install or store the pet water fountain where it will be exposed to weather or temperatures below °OC / °40F.

Product Overview

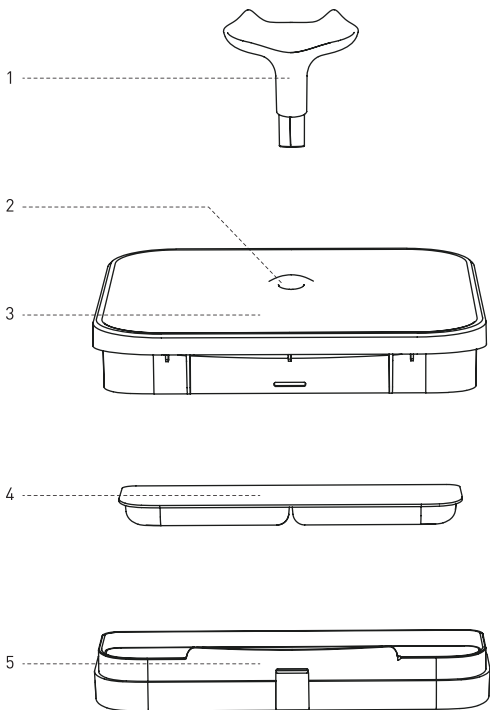

- 1. Spout
- 2. Water Outlet
- 3. Water Tray

- 4. Filter
- 5. Filter Tray

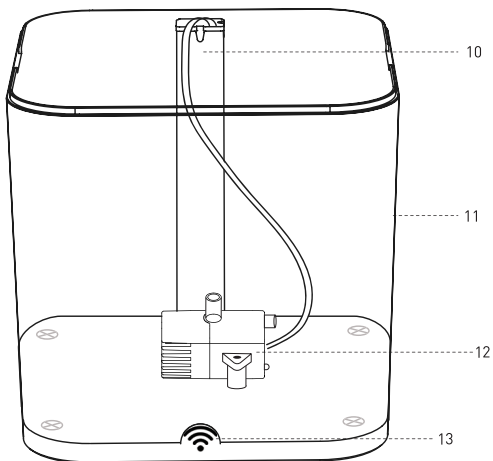
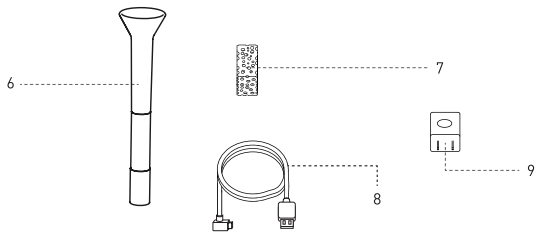

6. Water Pipe

7. Foam Filter

8. USB cable

9. Charger

10. Card Slot

11. Water Tank

12. Water pump with power cord

13. Double touch the wifi icon, can reset the pet water fountain.

How To Use

Step 1

Soak the filter in a clean bowl for 5 minutes.

Notes:

1. The filter must be fully soaked before the fountain is turned on; otherwise, water may not flow through the filter smoothly and cause spillage.
2. Please rinse the filter under the water tap thoroughly (illustrated)
3. Do not soak the filter in the water tank of the fountain in case of any surface dust.

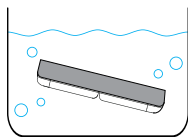

Step 2

Insert the Type-C USB power cord.

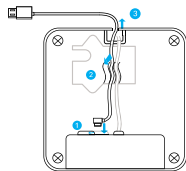

Bottom of product

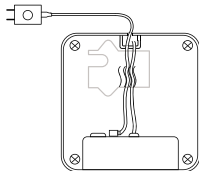
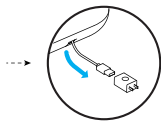

Elevation view

Step 3

Install the water pipe on the pump. Add water to the tank.

 **Note:**

Keep the water level between the Min and Max level. If the water under the Min level, the indicator light will turn to red color.

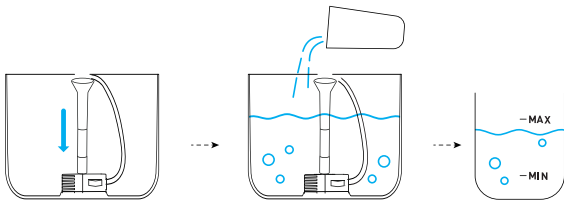

Step 4

Install the filter tray and place the filter on the filter tray. Press down firmly to make sure the pipe outlet comes out.

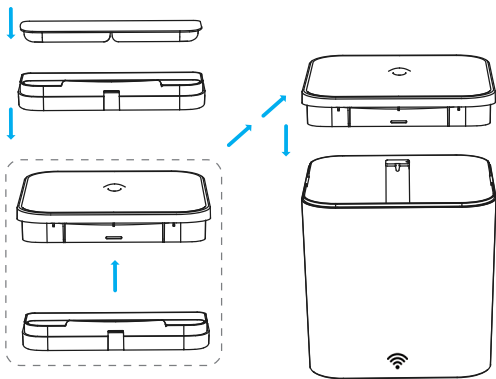

Step 5

Install the water tray. Whether to install the spout depends on your pet's drinking preference.

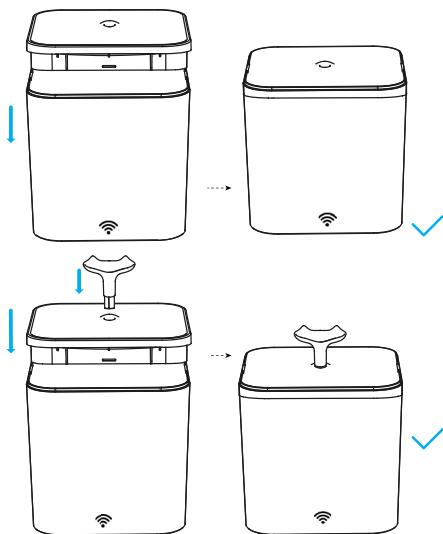

Step 6

Connect the power adapter.

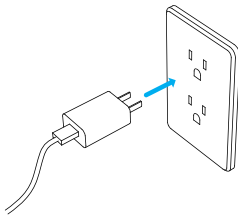

Care Instructions

1. Replace the filter and foam every 2 weeks.
2. Clean the pump and fountain every week.
3. To extend the life of pump, please add water before starting the machine.

How To Clean The Pump

Step 1

Remove the pump cover and impeller cover in sequence.

 **Note:**
The foam filter is in the pump cover, change the foam every 2 weeks.

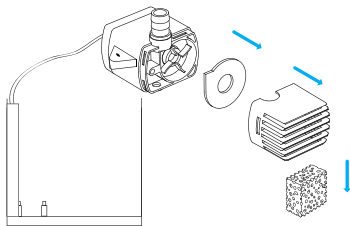

Step 2

Remove the impeller by the brush hook.

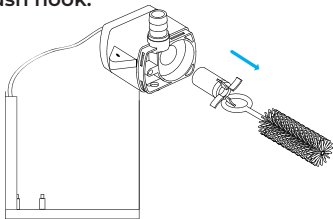

Step 3

Use the brush to clean the parts with water.

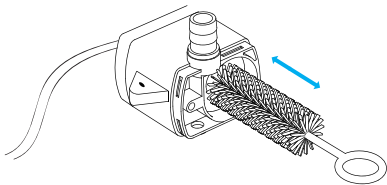

 **Tip:** The brush can also be used to clean the spout. Recommended to clean the spout every 2 weeks.

How To Bind App

Step 1

Download App

Please scan the QR code to download Penthouse Paws Smart app and complete the installation.

Or manually look up Penthouse Paws App on your phones app store.

SCAN THIS QR CODE



Step 2

App Setup & Add Device

1. Run the App, read and agree to the privacy policy
2. Register a new account or login to a registered account
3. Setup login and password.

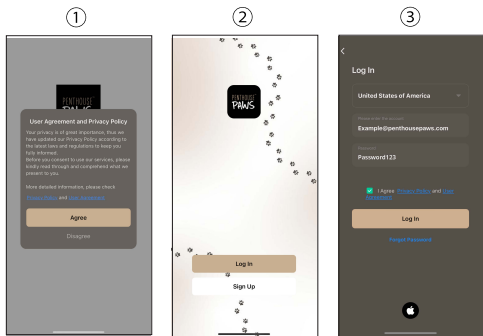

1. Click on " PH Paws Smart Water Fountain ".
2. Input your Wi-Fi Information.
3. Penthouse Paws APP will automatically connect to Smart Water Fountain.
4. Device added successfully

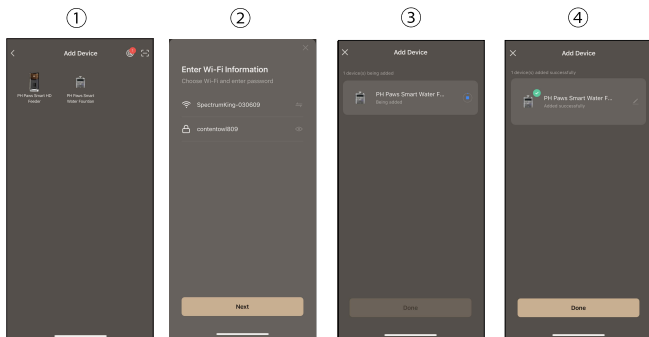

Step 3

Interface

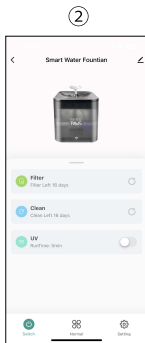
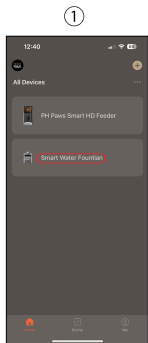

1. Click on " PH Paws Smart Water Fountain"
2. Review and make sure your interface matches

Step 4

Interface Introduction

1. Device name, It can be modified.
2. Fountain information and settings.
3. "Lack water" notification if there is low water.
4. Remind filter replace time.
5. Remind cleaning time.
6. Display UV running time.
7. Turn on/off the device.
8. Status Settings: Normal and Smart. (Smart mode setting cannot be adjusted as they are based on recommended values. Whereas on normal mode the settings can be adjusted to your preferences).
9. Fountain Settings: Set filter, Change Time, UV Runtime & More.

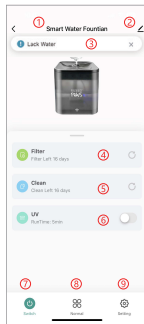

Step 4

Device Settings

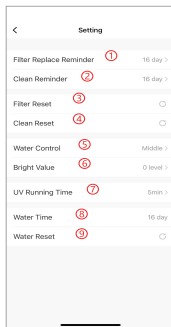

1. Set filter replace time.
2. Set clean pump, water tank time.
3. After replace filter, click it, start timing.
4. After clean pump, water tank, click it, start timing.
5. Adjust water stream.
6. Adjust the indicator light.
7. set UV running time.
8. Set change water time.
9. After change water, click it, start timing.

Step 5

Fountain Information and settings

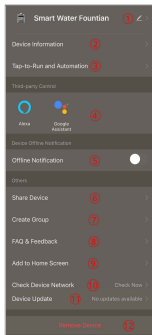

1. Change device name
2. View device ID, IP address, MAC, zone time, signal.
3. Tap-to-Run and Automation.
4. Smart Home compatible turn devices on/off.
5. If device is offline, APP will send push notifications after 30 minutes.
6. Share access to device to other users.
7. Create Group, Multiple devices connected to one group for easy use.
8. FAQ & Feedback.
9. Add to Home Screen.
10. Check Device Network.
11. Device Update.
12. Remove device will delete the Wifi information from the device. Then use a new account to connect.

Troubleshooting

Problem	Solution
Water keeps spilling out of the water tray.	The filter may not be fully soaked. Please soak the filter in a clean bowl (not in the water tank) for 5 minutes before the first use.
The pump stops working.	<ol style="list-style-type: none">1. Fill in water between MIN and MAX. The pump will fail if it runs dry.2. Clean the pump, water tank, and drinking basin.3. If the above solutions don't work, please contact us.
How often should I change the filters? Where to get them?	It's recommended to replace the filters every 2 weeks. Please contact us to purchase new filters.
Why do I need to soak the filter before first use?	The filters absorb more water (and therefore clean more water) when they're wet and expanded. Soaking the filter removes particulate matter that may have settled on the filter.
Water output speed slows down.	For the first use (or reuse after long-time storage), the water pump needs to discharge air, it's normal if the water output speed slows down.

Specifications

Model	PHP WF-004
Power Adapter	Input: 240-100V 60/50Hz Output: 5V/1A
Material	ABS
Water Tank Capacity	2.2 L
Dimensions	160*160*175 mm / 8.9 x 5.6 x 5.5 inch
Net Weight	700g/24.7oz

Warranty

- 12 month warranty
- Life-time support

Please contact help@penthousepaws.com for warranty issues or questions.