



# Outdoor Kitchens - Installation & User Guide



Installer please leave this with homeowner

# Thank You!

Thank you for purchasing a Stono Outdoor Kitchen! We are confident this quality product will last you for years to come. If you need further help or additional information regarding installation, please do not hesitate to reach out to us!

## Included Parts & Tools

The following parts and tools are included with your outdoor kitchen.

Leveling Legs: 4

Storm Tie-down Straps: 4

## Photos of Completed Projects

We would love to see pictures of your finished and installed project! Please send images to [support@stonooutdoor.com](mailto:support@stonooutdoor.com). High quality images will likely be featured on our social media or website!



# Outdoor Kitchens & Islands

## Shell Construction

Your kitchen should arrive pre-assembled, however large kitchens may arrive in multiple sections. If your kitchen contains multiple sections please see the following instructions. Otherwise, skip to page 4.

The primary fastening mechanism is a slot and cleat system that is laser cut in the supports and panels. The vertical supports will have slots cut in them that correspond with cleats that are cut in the front and back panels.

Connect your kitchen sections by sliding the cleat system of each section into the corresponding slots of the adjoining section. Using a rubber mallet, ensure cleats are fully seated.

### Legend

Vertical Support: V1, V2, Etc  
Back Panel: B1, B2, Etc  
Front Panel: F1, F2, Etc

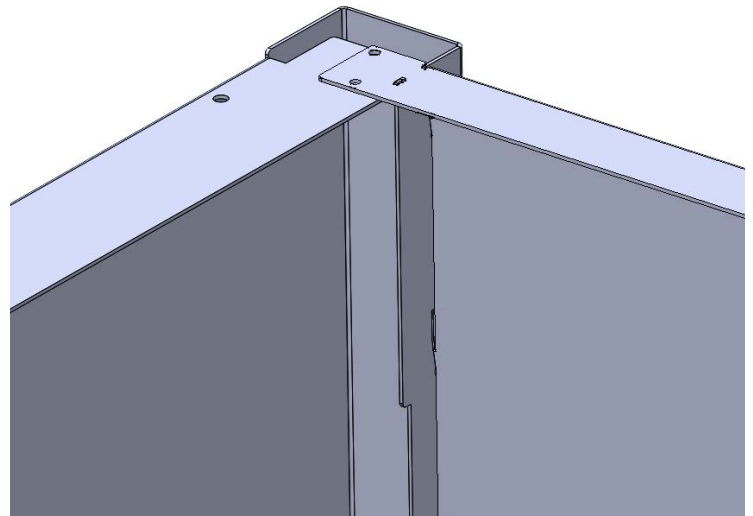
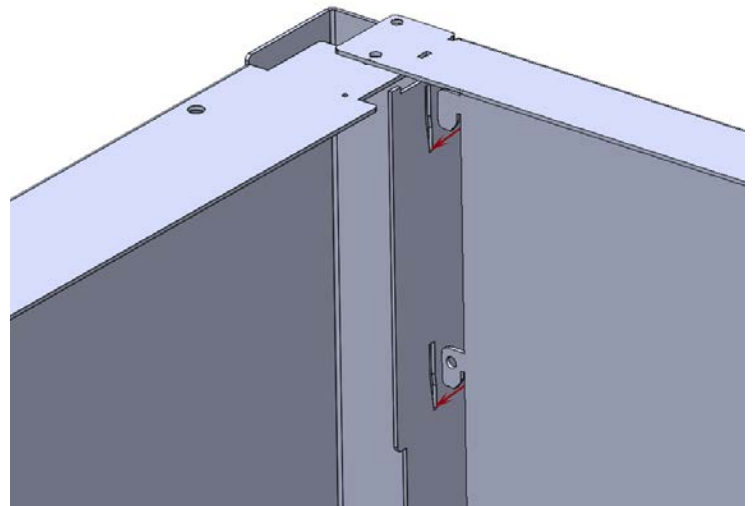
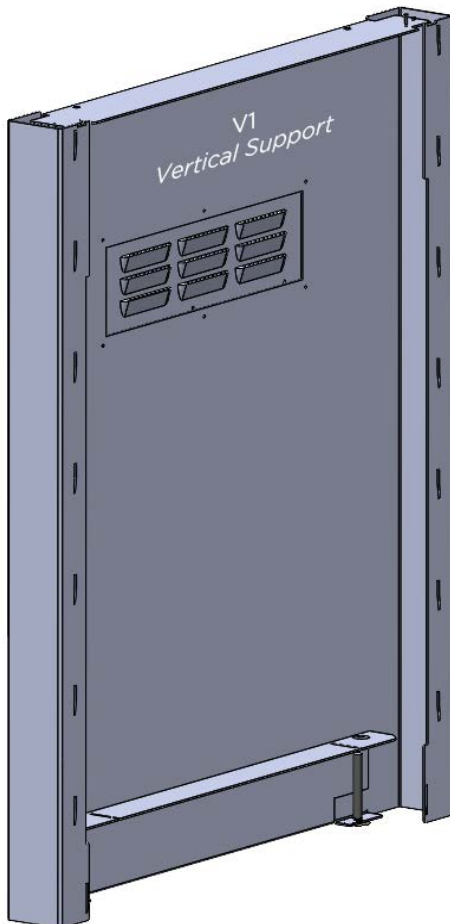

## Shell Construction Continued

Although your kitchen design and layout may vary, always follow the sequence of numbers for each adjoining section. Repeat this process until all of the Vertical Supports and Panels are connected.

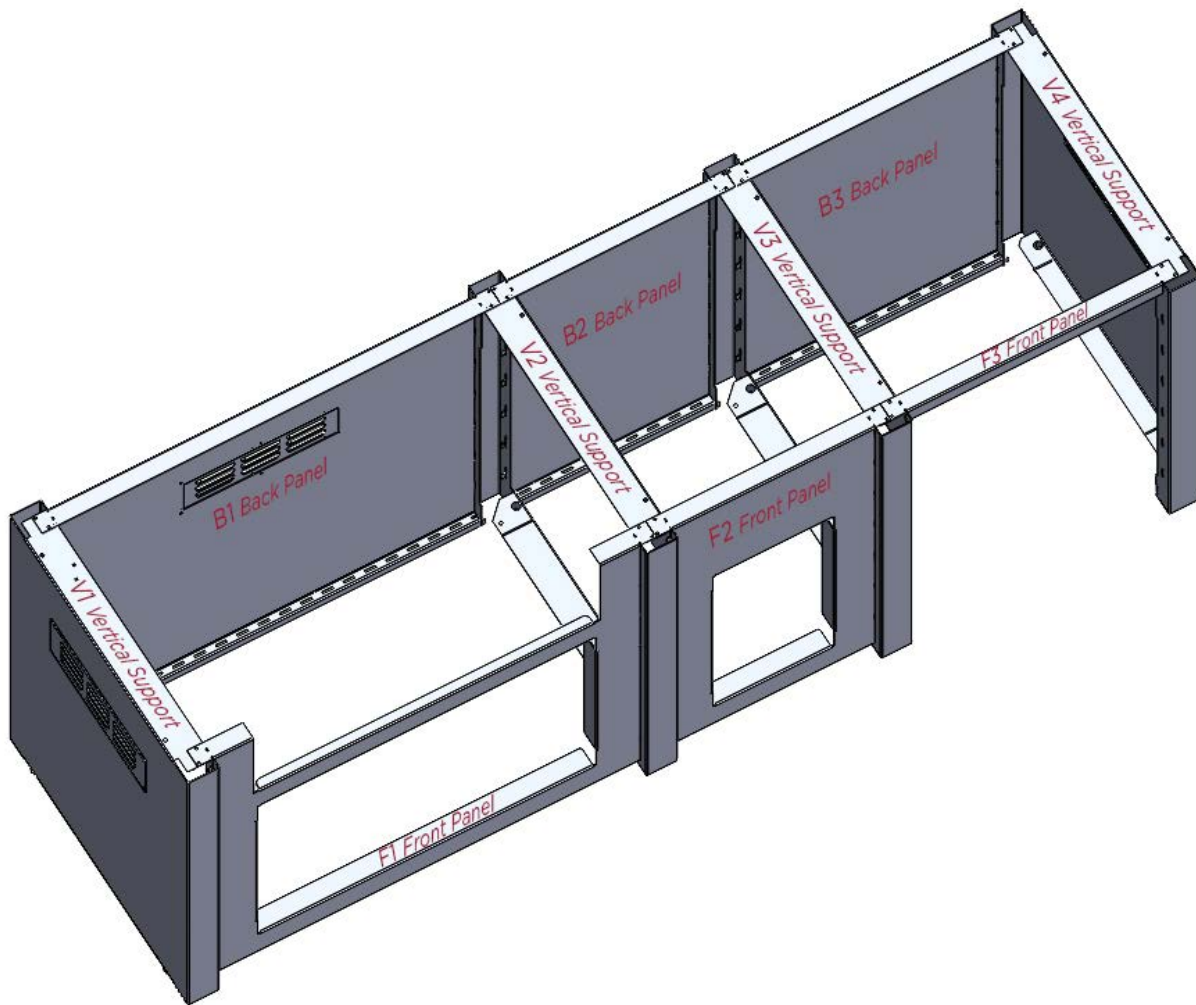

---

Using the provided screws, fasten each Support and Panel together in the corners of each section.

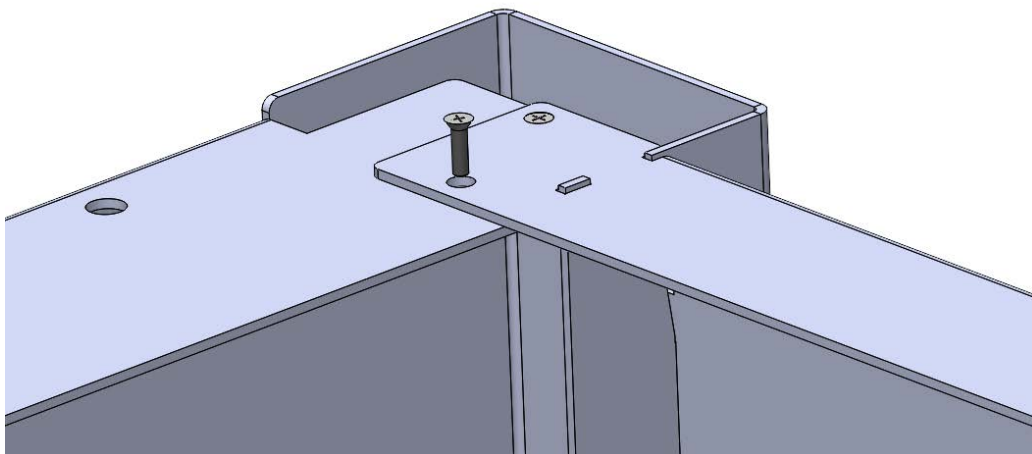

## Leveling System

Each unit will come with an adjustable leveling kit. If desired, adjust with the included allen wrench as needed to achieve level. Using the leveling feet will be at the discretion of the installer, we do not require that the feet be used to elevate the product. If desired, insert included storm tie-down straps over leveling legs, and secure in place with the appropriate fasteners (not included).

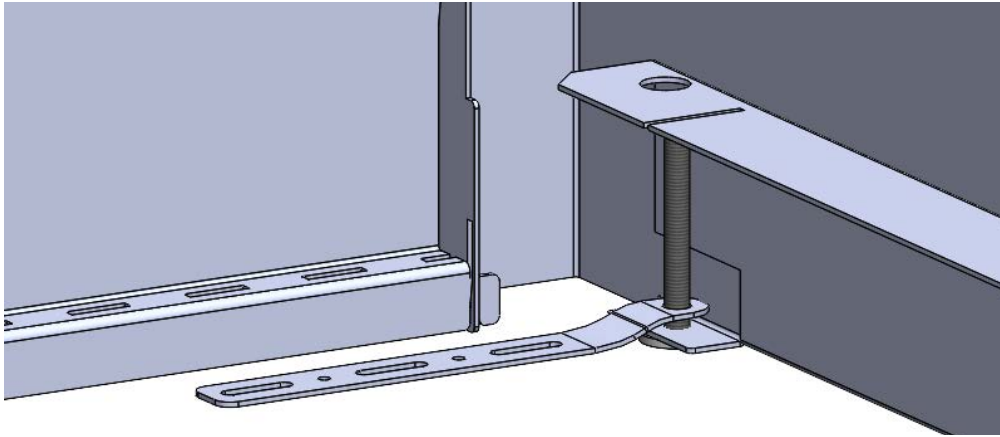

---

## Component Installation

Stono Components will come pre-installed. If you purchased 3rd party Components, please follow the manufacturer instructions for installation. Typically, the component will be fastened to the formed return in the opening of the metal front panel of the kitchen shell.

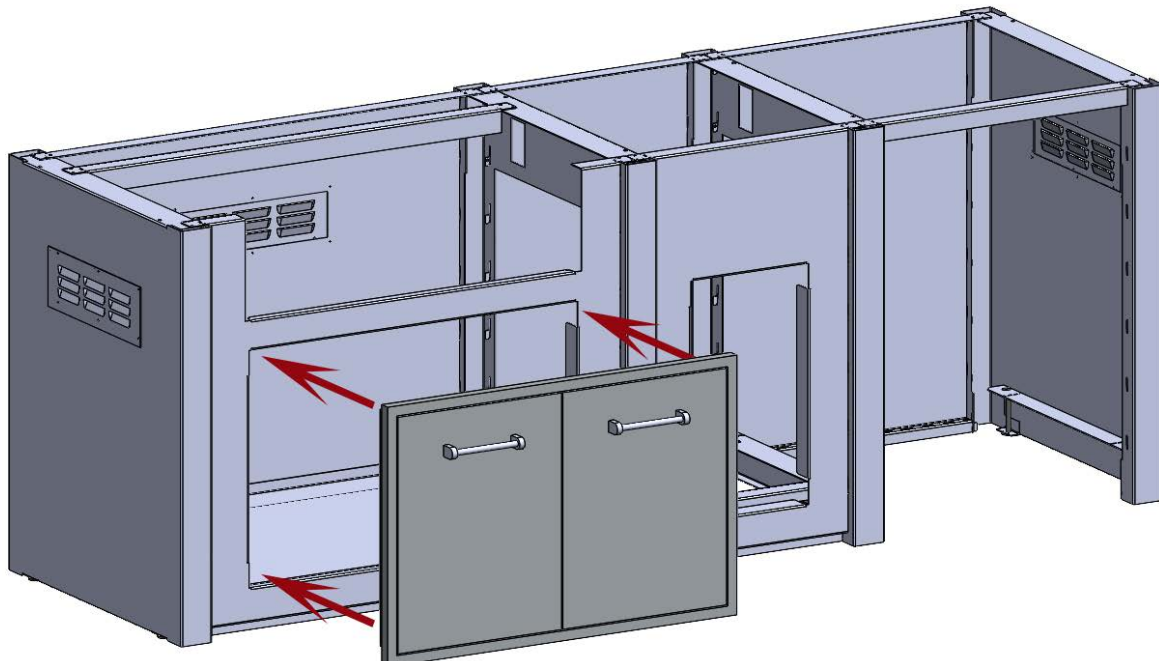

## Countertop Installation

Lower the countertop into place on top of the kitchen. The countertop should cover the top of the kitchen shell, and overlap downwards several inches on all sides. Glue or silicone may be used to secure the countertop, but will make it very difficult to remove in the future to replace panels or disassemble the kitchen.

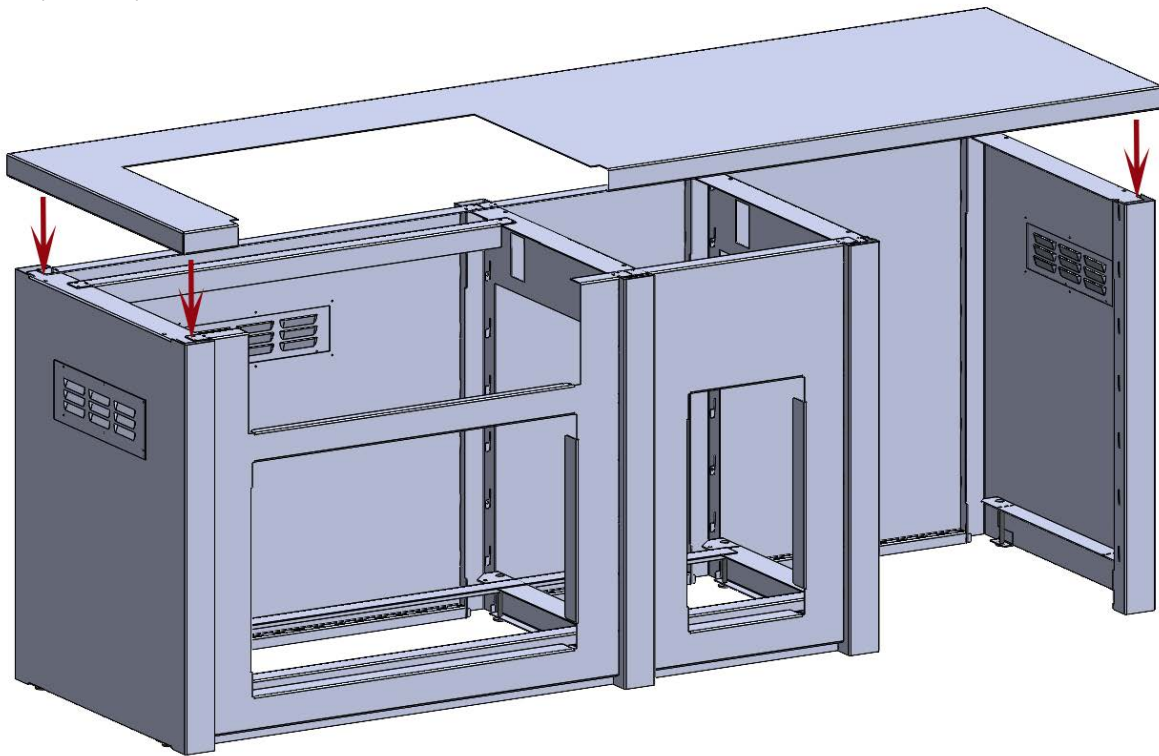

---

## Grill Installation

Your countertop will be pre-cut to the specifications provided for your specific grill. Please trim the provided Gasket as needed for your application. Following any specific instruction provided by the manufacturer, install your Grill into the countertop.

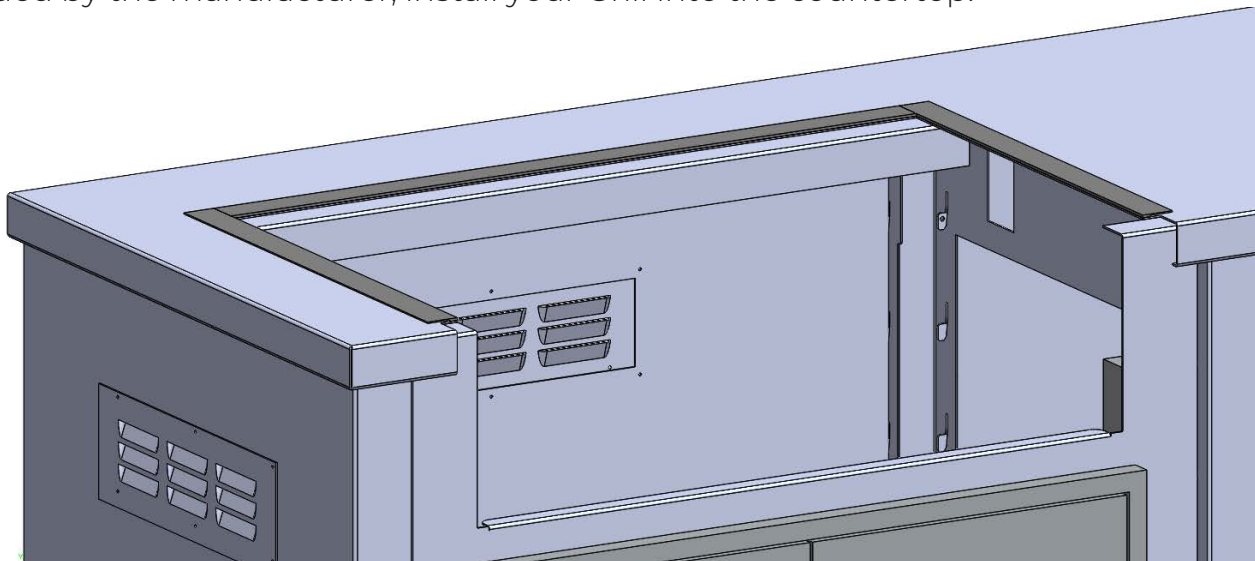

# Completion

Install any remaining components, and enjoy!



## Operation & Maintenance

- Excessive heat can cause damage to the finish. A very hot wood or gas fire, or hot coals and embers coming in contact with a finished surface can cause discoloration or more serious damage. This type of damage, caused by overheating, is considered abuse and is not covered under warranty.
- Your kitchen and countertop powdercoat finishes can be cleaned using a damp cloth and soap or mild household cleaner, or rubbing alcohol for tougher stains. For Stainless finishes, please use standard Stainless cleaners and supplies. To avoid damage to the finish, abrasive cleaning products and cleaners containing ammonia or other harsh chemicals should be avoided.

## Warranty

Your Stono Products are covered by a 5 year limited warranty. For more information, please visit [www.stonoooutdoor.com](http://www.stonoooutdoor.com).

### **WARNING**

This product can expose you to chemicals including Carbon Black, which is known to the state of California to cause Cancer. For more information go to [www.P65Warnings.ca.gov](http://www.P65Warnings.ca.gov)