



External air intake



33cm Logs



1.8kg wood per hour



Easy to remove ash tray



Optional Heat Bank available



Andorra

National Certificate of Compliance No; H793/1214

Tested and complies with AS/NZS 4012:2014, AS/NZS 4013:2014

Andorra provides ultra-low wood consumption and efficient clean burning. It is one of Euro Fireplaces most popular models. Easy to operate, the Andorra will start heating within 20min of lighting.

Andorra Clearances

Tested to comply with AS/NZS 2918:2018

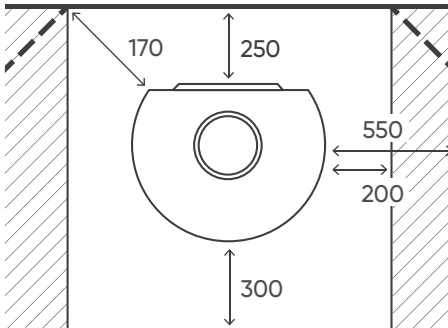

Capacity	240sqm
Efficiency	Aus 67% Eu 82%
Emissions	0.8g
Wood Usage	1.8kg/hr
Weight	110kg
H/W/D	1097/510/415
Heat Bank	Optional 20kg
Ember Retention	WO/HB - 6 hr+ W/HB - 7 hr+