

# **MOJAB**

**OFF-ROAD GEAR**



[www.mojaboffroad.com](http://www.mojaboffroad.com)

Thank you for choosing Mojab Jack.

### **WARNINGS**

- ◆ The Jack is intended for off road use in vehicle recovery situations.
- ◆ The Jack has not been designed for use in a horizontal orientation, Jack performance cannot be guaranteed when used on extreme angles.
- ◆ Do not use for vehicle maintenance or wheel removal.
- ◆ Do not use under a raised vehicle.
- ◆ Do not use under a vehicle that is supported by a Jack.
- ◆ Do not put any part of your body under a vehicle when Jack is being used as the only support device.

### **OWNER RESPONSIBILITIES**

- ◆ Do not operate or repair the jack without reading this manual.
- ◆ Follow all instructions and operational procedures.
- ◆ Inspect the Jack for proper operation and function prior to every use.

### **OPERATOR SAFETY WARNINGS**

- ◆ Use good lifting technique(straight back, using legs to lift).
- ◆ When the Jack is not in the carrying bag, carry the Jack with two hands, horizontally, across the front of the body.
- ◆ When the Jack is in the carrying bag, use the bag's carrying handles to lift.
- ◆ Do not carry the Jack on one shoulder, it increases the risk of injury to the person who is carrying the Jack, as it is unbalanced and unstable.
- ◆ When carrying the Jack and turning, be aware of the surroundings, to prevent hitting people or objects.
- ◆ The Jack was designed to reduce risks and increase safety. Operation of the Jack may have the potential to cause harm if used improperly. Ensure all instructions are read and understood prior to operation of the Jack.

#### **1.Position**

Position the Jack to only lift in the areas of the vehicle specified as off road jacking points.

#### **2.Always use support stands**

After lifting the vehicle, always support the load with appropriately rated vehicle support stands before working on the vehicle.

#### **3.Do not overload Jack**

Do not overload the Jack beyond its rated capacity. Overloading the Jack can cause damage or failure to the Jack.

#### **4.Always use on hard and level surface**

The Jack is designed only for use on hard level surfaces capable of withstanding the load. Use on unstable or other insufficient surfaces can result in Jack instability and possible loss of load.

#### **5. Insert hook as far as possible**

Insert the hook as far as possible to apply the most load closer to the body. Failure to insert enough of the hook can cause the Jack to become unstable, fail, damage vehicle or loss of load.

6. Do not raise or lower the Jack unless tools, equipment and people are clear  
When lowering the Jack ensure the vicinity is clear. Ensure there are no tools or equipment left under the vehicle before lowering. Always lower the Jack slowly and in a controlled manner.

7. Do not use the Jack to support or stabilize a load

Using the Jack to support or stabilize a load may result in unexpected movement and result in serious injury, being crushed and/or death. Always securely chock and block (stabilize) the load to be lifted. Never place any part of the body under a raised load without properly chocking and supporting the load.

8. Never use the Jack on curved or tubular vehicle parts

Failure to follow may cause the Jack to slip and damage the vehicle and/or cause injury to the operator. Use a Jack adaptor to lift from wheel rims or bumpers.

9. The use of heavy duty rigging/winch gloves is recommended

10. Do not move or dolly a vehicle while the Jack is in use

11. Stay alert and use caution when operating Jack

Do not use the Jack when tired, incoherent, dizzy or under the influence of drugs and/or alcohol. The operator MUST be alert and watch the lifted load during operation of the Jack.

12. Training

Read this manual before use. Do not allow anyone who has not read this manual and/or does not understand the instructions and safety requirements to use the Jack.

13. Inspection

Using a Jack that is not in good working condition and free of debris may cause property damage and/or loss, serious injury and/or death. Inspect the Jack before each use. Ensure the Jack is not damaged, excessively worn, or missing parts. Do not lubricate the shaft.

14. Operating Temperature

The Jack has been designed to operate within a temperature range of -20°C to +50°C.

15. Do not lift any object or vehicle that is occupied.

All passengers/persons must vacate the object or vehicle prior to being lifted.

16. Chock and Block (stabilize)

A chock is a wedge which is placed under the un-lifted wheels to inhibit the wheels from rolling.

When you block a load, you secure and support a load that has been lifted.

Apply park brake in the vehicle before operating the Jack.

Chock the wheel opposite the end being lifted.

With the vehicle lifted, place the block or stabilize under an appropriate location on the vehicle.

The block or stabilizer must have a load rating greater than the load being lifted.

17. DO NOT MODIFY the Jack in any way. Unauthorized modification may impair the function, lifespan and/or safety of the Jack. The Jack was designed for specific applications.

18. ALWAYS CHECK FOR DAMAGED OR WORN out parts before using the Jack. Broken parts will affect the equipment operation.

19. When the Jack is not in use, the Jack must be stored in the bag provided. Inspect for good working condition prior to storage and re-use.

20. Keep away from children.

21. Not tested for use in potentially explosive environments.

22. Not tested for use in areas with potential for sensitivity to static electricity.

23. Not intended for use in the lifting of dangerous materials.

24. Not intended for the use of contact and/or preparation of food.

25. Not intended for use in marine environments and/or on maritime vessels.

## JACK COMPONENTS

### ◆ KNOW YOUR JACK

Compare these illustrations with your Jack BEFORE operation to become familiar with the location of various Jack components.

Ensure all markings are present and clearly legible prior to each operation.

Jacket Sleeve is for preventing the direct contact between vehicle and jack body.

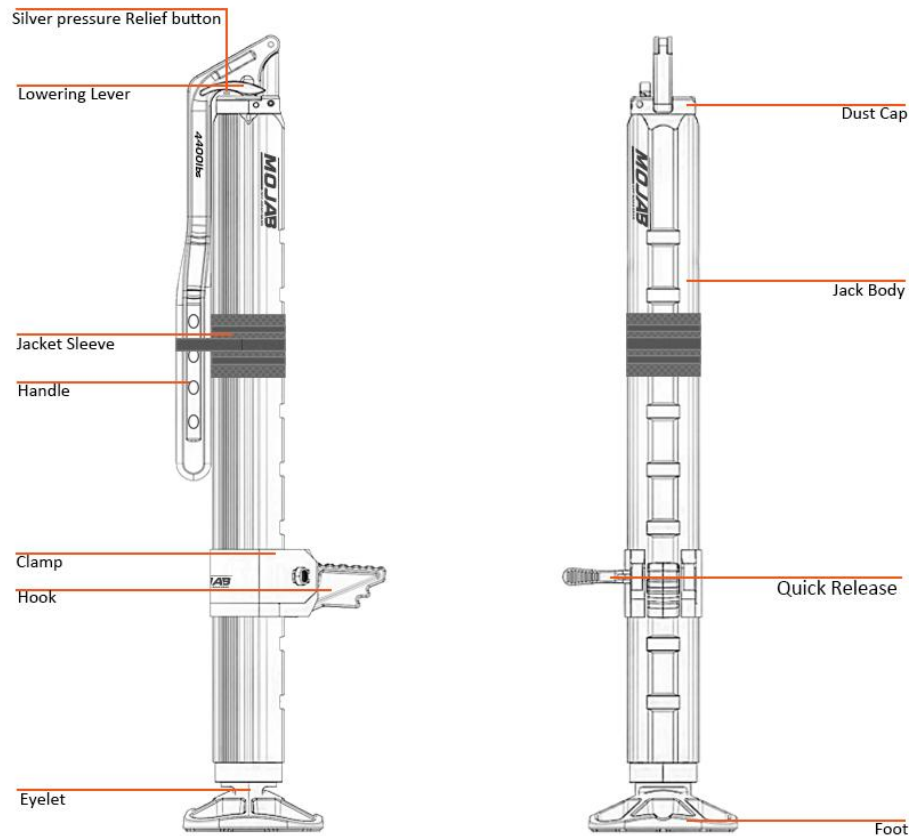

## JACK OPERATION BEFORE USE

Occasionally during shipment and/or handling, air becomes trapped within the hydraulic system which interferes with the Jack's performance. To release the trapped air, please perform the following with the Jack in an upright position:

- ◆ 1. Depress the black lowering lever for a period of 5-10 seconds.
- ◆ 2. Depress the silver pressure relief button on top of the Jack for 5-10 seconds.
- ◆ 3. Pump the Jack handle several times to ensure no bubbling noises are present.
- ◆ 4. Ensure the pump operates smoothly before putting into service.

## **OPERATING PRINCIPLES**

When the lowering lever is not depressed, upward strokes of the Jack handle draws oil from the reservoir tank into the piston cavity. Hydraulic pressure holds the valve closed, which keeps the oil in the piston cavity.

◆ Downward strokes of the Jack handle releases oil into the cylinder, which forces the pump system upward inside the shaft.

◆ When the Jack reaches maximum extension, oil is bypassed back into the reservoir to prevent an overextended ram stroke and possible damage to the Jack. Depressing the black lowering lever allows the oil to flow through the pump and back into the reservoir tank. This releases hydraulic pressure from below the pump system and allows the Jack to retract (lower).

## **WARRANTY: 2 YEARS**

### **MAINTENANCE INSTRUCTIONS**

The Jack is to be only serviced by Mojab specialist.

#### ◆ CHANGING OIL

It is recommended that you return your Jack back to Mojab for servicing if an oil change is required.

#### ◆ LUBRICATION

DO NOT attempt to lubricate the shafts, they are self-lubricating and will lubricate themselves upon re-use.

#### ◆ CLEANING

Periodically check the external upper and lower seals. The seals keep contaminants from entering the Jack. Wipe with a cloth when necessary. Check the shafts for signs of rust or corrosion. Clean as needed and wipe with an oily cloth.

Rinse the Jack with fresh water. Never use high pressure and never use chemicals to clean the Jack.

Avoid operating the lowering lever or depressing the pressure relief button while cleaning.

#### ◆ STORAGE

Store Jack with the shaft fully retracted (Jack lowered), the handle retained in the jacket sleeve and the hook in the upright position.

Ensure the Pressure Relief Button is not depressed while in storage. Storage with Pressure Relief Button depressed may cause oil leakage.

When not in use, the Jack should be stored within the supplied carry bag and it is best to put it upright. If the Jack is transported within a vehicle, ensure the Jack is adequately restrained so as to not become a projectile in the event of a collision.

## How to use your JACK RAISING THE JACK

### ◆ 1. VEHICLE SAFETY

Stabilize the vehicle by applying chocks to the wheels at the opposite end of the vehicle being lifted.

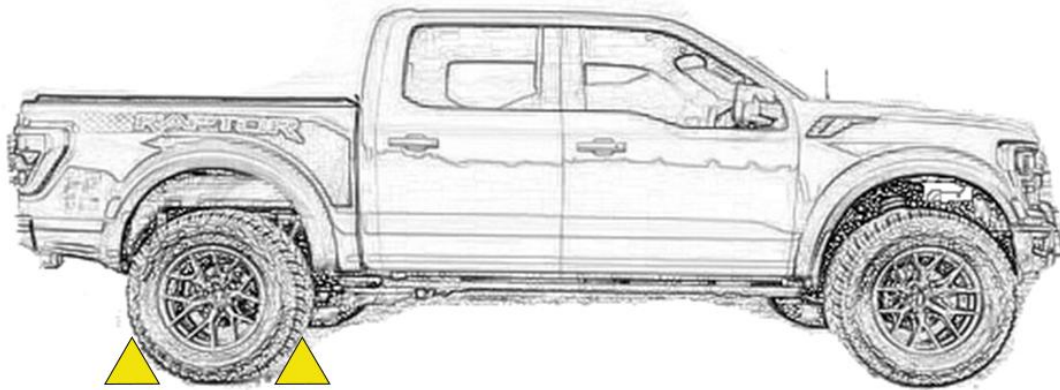

### ◆ 2. CLAMP LOCK

To position the hook for lifting, release the lever on the side of the clamp. The quick release lever does not need any adjustment; pull the lever away from the body of the Jack to release the clamp. If the clamp no longer applies enough clamping force; close the lever and adjust with a hex key until the hook is adequately clamped. Do not over tighten. If greater clamping force is required; With the clamp lock in the closed position, use a 5mm Hex Key to tighten the clamp bolt. Do not exceed 4.5Nm.

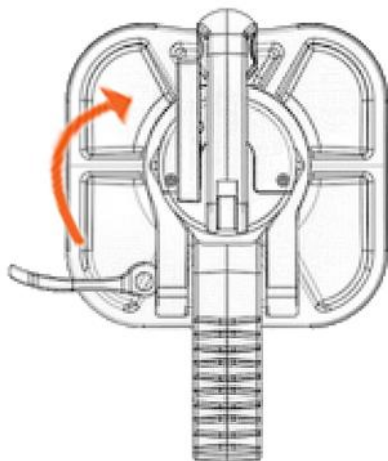

### ◆3.HOOK POSITION

Rotate the hook to a horizontal position and raise the hook to the desired groove closest to but just below your target jacking point.

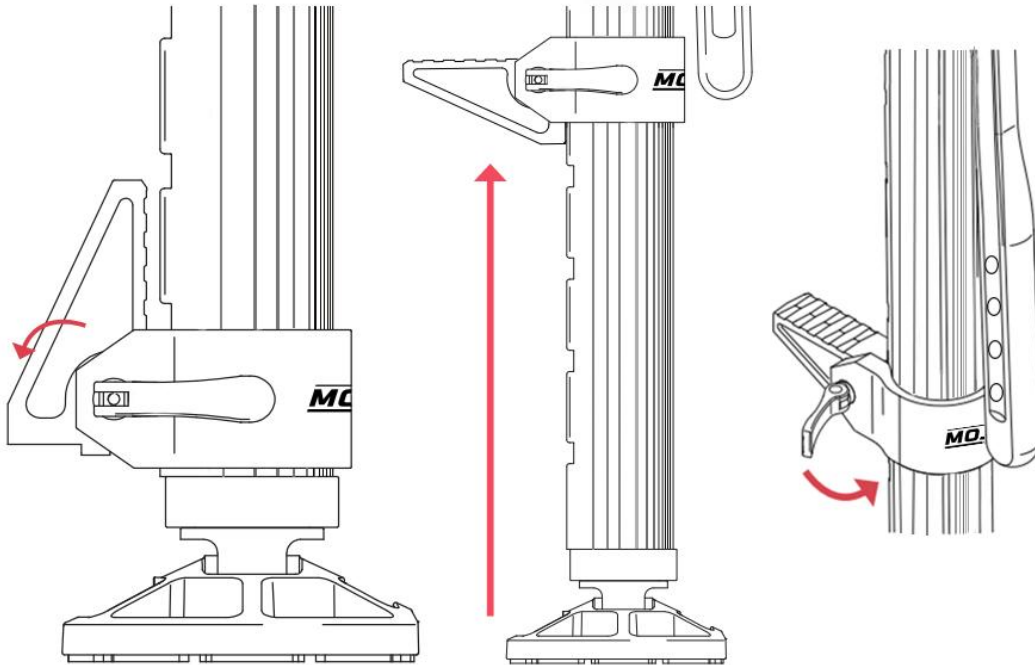

Close the quick release lever.

NOTE: It is important that you allow for some height between your jacking point and the hook so that the Jack can be removed safely once you lower the Jack.

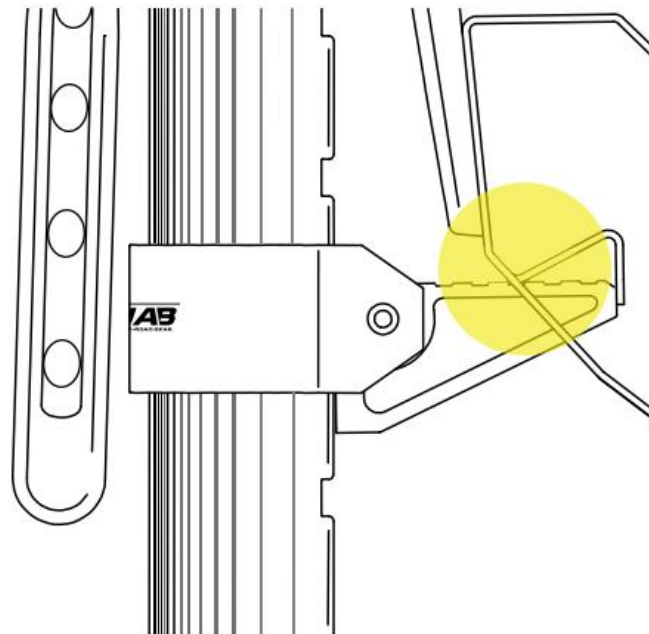



#### ◆4.FOOT ORIENTATION

Before jacking a vehicle,check the foot orientation. The foot orientation determines the way the Jack may pivot as the vehicle is raised. The shaft rotates inside the body; to rotate, stand on the foot and twist the body.

NOTE: The Jack may blow over if left unattended in high winds.

#### WARNING:

Failure to consider the movement in the foot may result in property damage and/or serious injury. The vehicle will move in an arc motion and the Jack can become unstable if not aligned properly.

#### ◆5.HOOK ENGAGEMENT

It is recommended that you push the hook as far in as possible and to ensure a secure lift.Some bars may restrict the depth which the hook can be inserted. Do not lower the hook below the restrictive plate as this may cause damage to the bar.

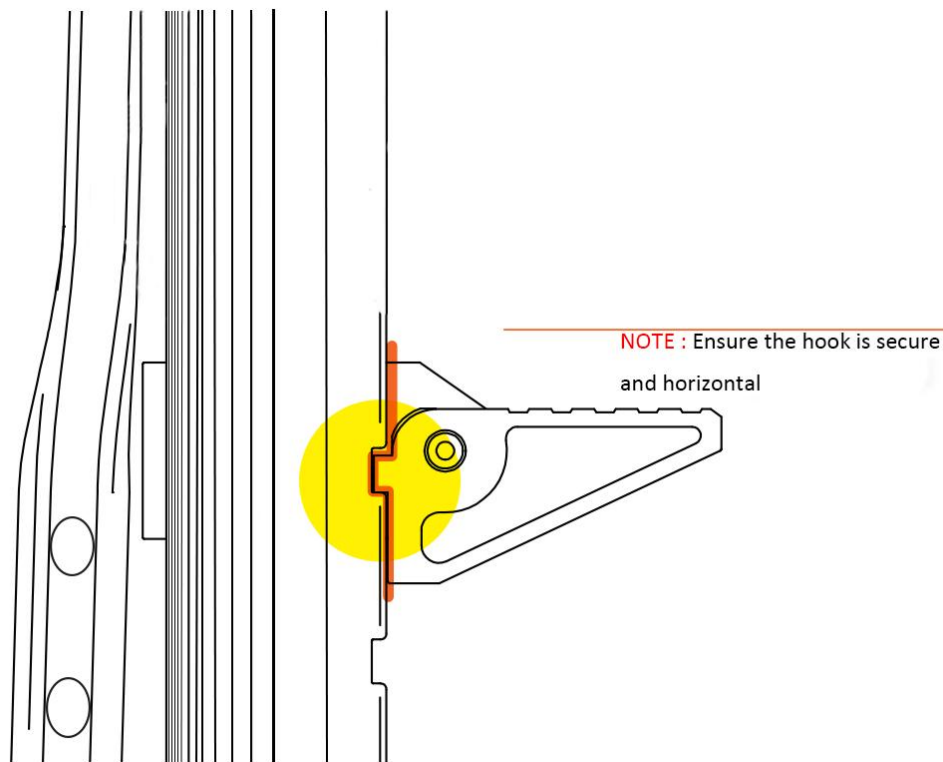

◆ 6. VEHICLE INTERFERENCE

If the handle linkage is going to interfere with the vehicle, move the hook to a lower groove and pump the Jack to raise the hook to the target jacking point.

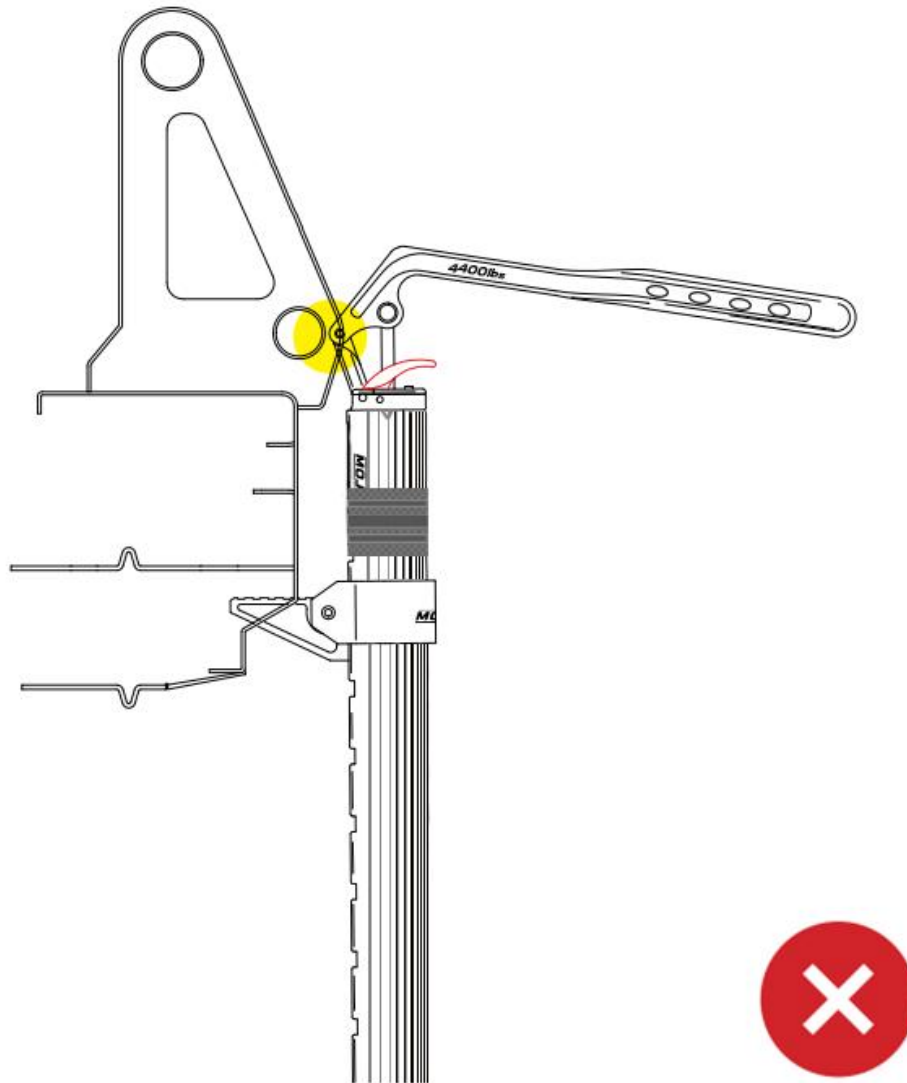

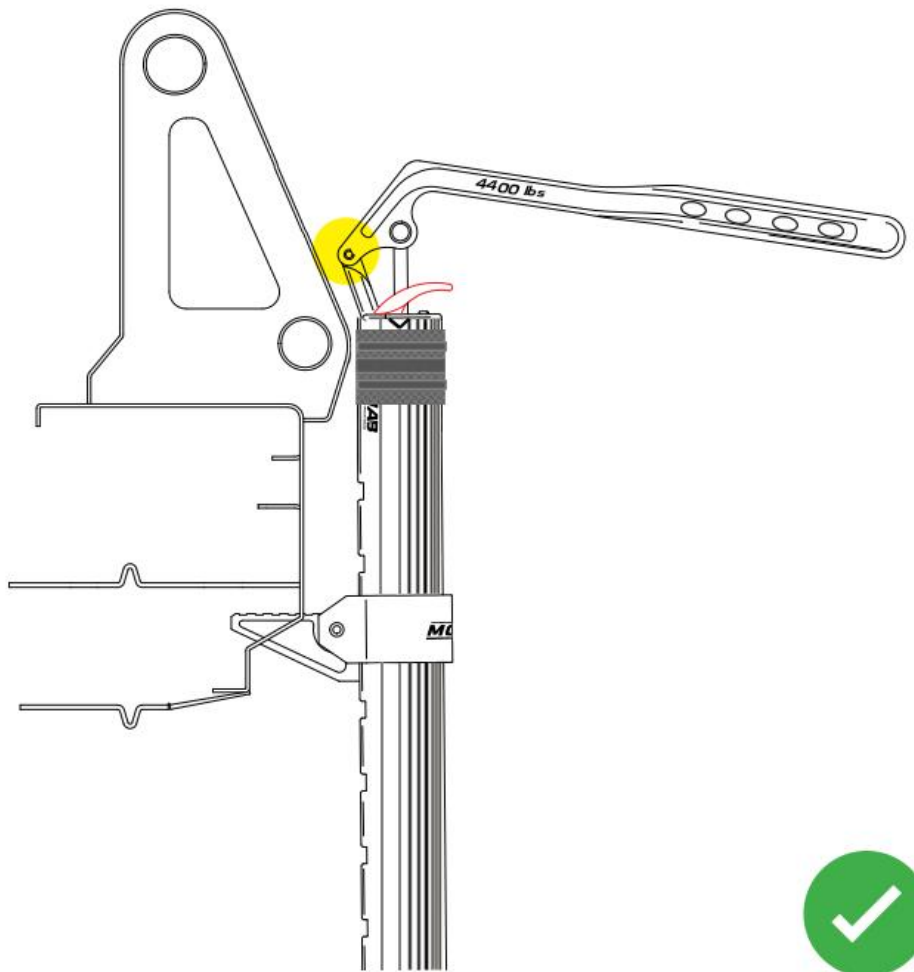

#### ◆ 8.JACK PUMPING

Raise the Jack slightly and re-check that the jacking point and foot position is secure. Use the most appropriate pumping method for the weight and/or your personal geometry when lifting a vehicle.

When the Jack is under light load, use the full stroke of the handle.

As the weight increases and the Jack raises, consider a smaller pumping action.

Doing so keeps the force below shoulder-line and reduces effort required by the operator.

As the load increases on the Jack, the handle will require increased input force by the operator to operate.

Please consider the mass you are lifting and operator technique to achieve the desired lift.

NOTE: Full stroke of the handle is ideal for setup and low lifts.

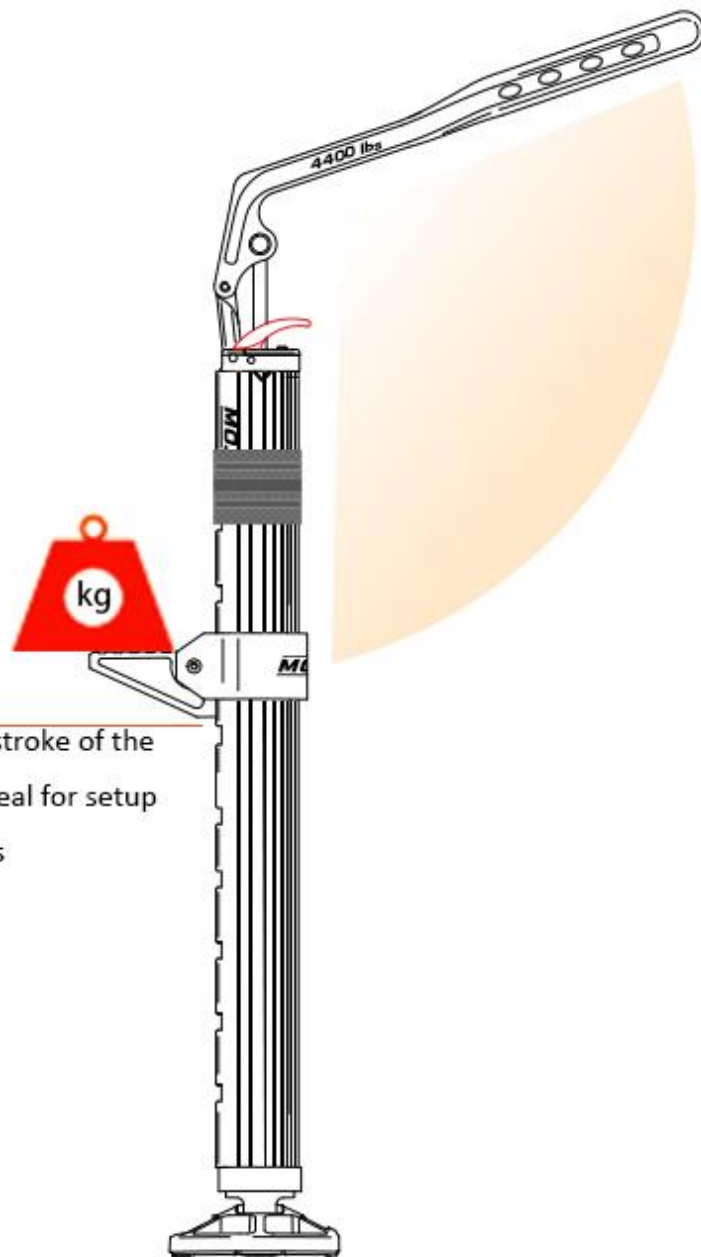

**NOTE:** Full stroke of the handle is ideal for setup and low lifts

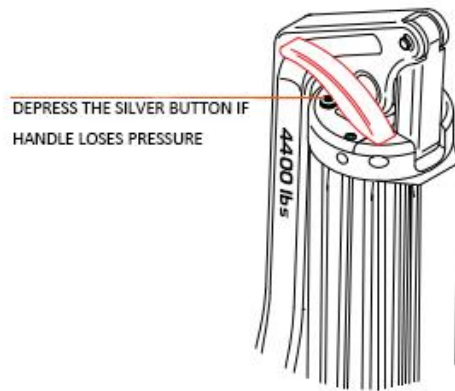

DEPRESS THE SILVER BUTTON IF  
HANDLE LOSES PRESSURE

**NOTE :** If the handle loses pressure during pumping, depress the silver pressure relief button which is located under the red lowering level. this will allow the jack to equalize

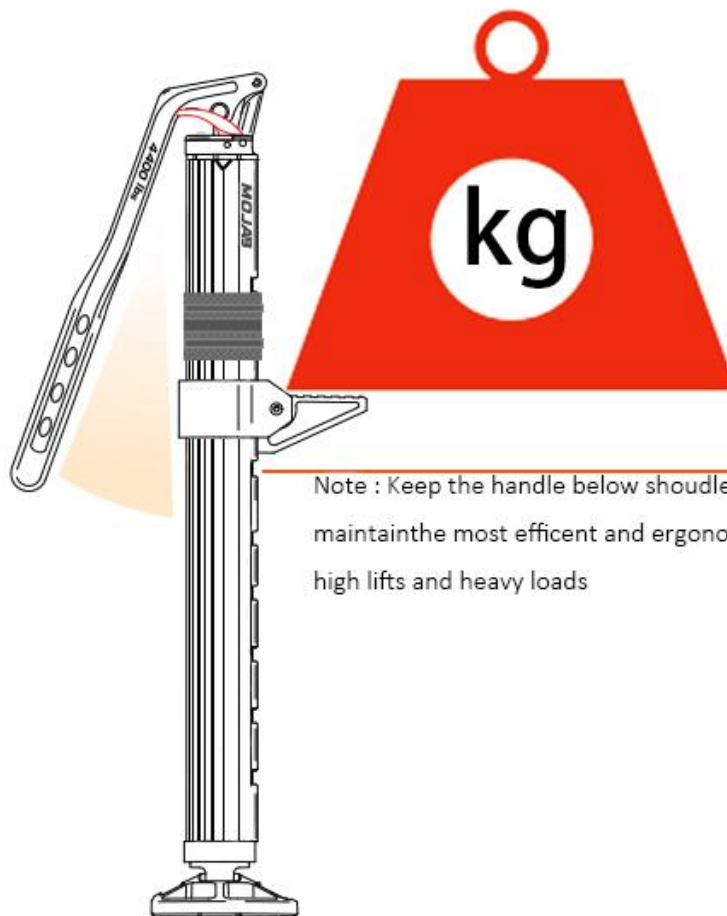

Note : Keep the handle below shoulder level to maintain the most efficient and ergonomic action during high lifts and heavy loads

◆ **NOTE:**

The Jack is designed for single person use only.

If at any time during use operation becomes difficult, STOP.

Seek assistance if you cannot maintain control of the handle force during lifting operations.

## HOW TO USE YOUR JACK

### ◆VEHICLE SAFETY◆

Raise the vehicle to desired height.

Once raised, transfer the load to an appropriately rated Jack stand.

### ◆WARNING 1:

Raising an inflated tyre more than 50mm (~2") above the ground or attempting to lift more than one wheel at a time may result in the vehicle tipping over, unexpected movement, serious injury and/or death. Always raise an inflated tyre less than 50mm (~2") and only one tyre at a time. Use only certified Jack stands and adhere to their operating instructions.

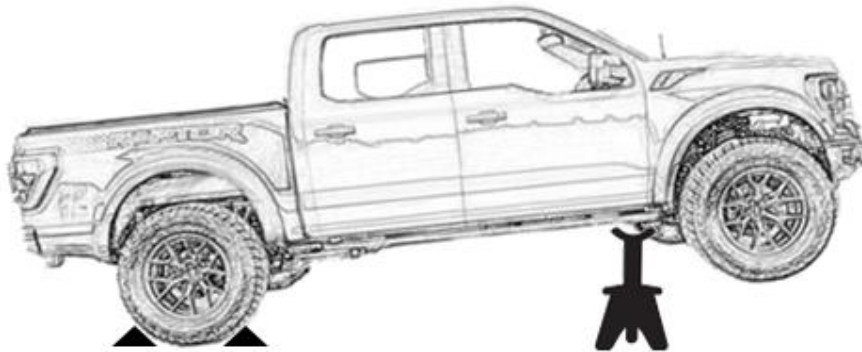

### ◆WARNING 2:

Do not put any part of your body under the vehicle when Jack is being used as the support device.

## HOW TO USE YOUR JACK

### ◆LOWERING THE JACK◆

#### 1.VEHICLE SAFETY

Raise load high enough to clear the Jack stands, then carefully remove Jack stands (always in pairs).

#### 2.LOWERING

Using a slow and smooth action, depress the BLACK lowering lever. If the Jack has not been used recently, initial force on the lever may be higher to break the seal of the valve. Correct technique when using the lowering lever will ensure safe and controlled descent.

#### 3.DESCENT CONTROL

The initial two-thirds of the release lever travel is intended for slow lowering of the loaded Jack. The final third of the lever travel is for fast lowering of the unloaded Jack. Do not use the fast lowering speed while the Jack is loaded.

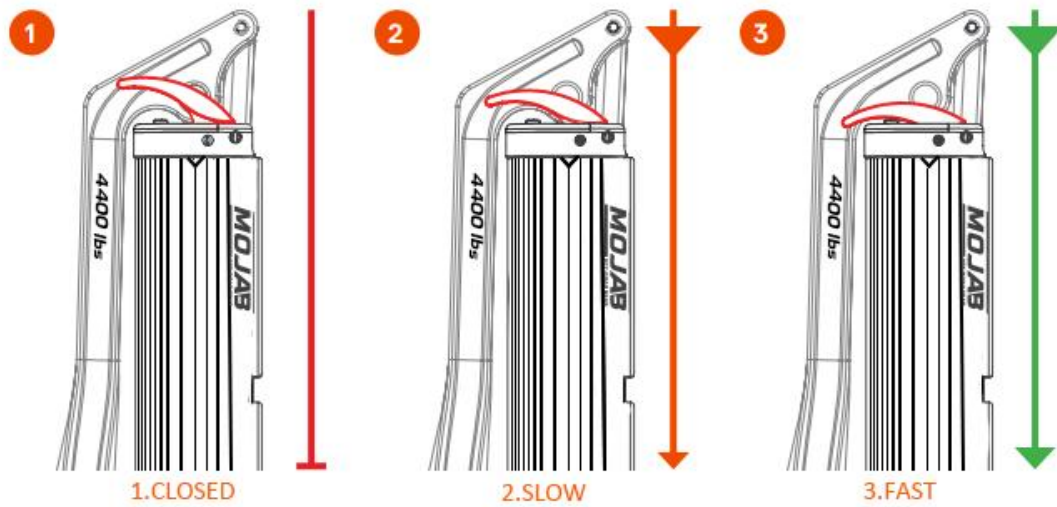

#### 4. JACK STORAGE

After removing the Jack from the vehicle, fully depress the release lever and apply downward pressure on the Jack to fully compress it to its storage position.

Lower the handle and press it into the retaining fingers of the jacket sleeve. Open the quick release lever and rotate the foot upward, close the quick release to hold the hook in place.

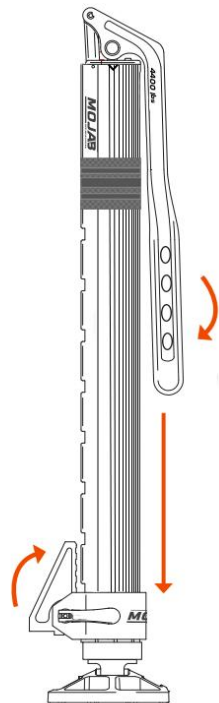

### ◆ JACK OIL LEAK AND SPILLAGE

The Jack uses Hydraulic mineral oil, this fluid is only toxic if ingested. If contact with hydraulic fluid occurs, wash your hands thoroughly prior to contact with food or drinks.

Avoid oil interacting with any rubbers, vehicle paint, plastic or upholstery.

Promptly clean oil spillages using warm soap water, then rinse immediately with fresh water.

Jack is filled with 1200ml of oil.

Jack never needs more than approx. 1100mls; the extra fluid ensures that the pump always has enough fluid. Small leaks won't need to have Jack topped up.

To ensure Jack has enough fluid:

\*Raise Jack to full extension without load.

\*If Jack reaches its end stop without any air sucking noises, it has sufficient fluid and does not need to be refilled.

\*If Jack does not reach full extension, or begins to produce "air sucking" or "gurgling" noises during pumping, Jack may need extra fluid to operate to its full extension.

\*Topping up the fluid requires disassembly, and must only be done by authorized service personnel, as incorrect disassembly/reassembly may cause Jack to malfunction.

NOTE: Topping up with excess fluid may cause malfunction, including leakage and inability for Jack to lower fully.

### JACK SPECIFICATIONS

Min.Lifting Height	6 inch
Max.Lifting Height	48 inch
Travel	21.25 inch
Lifting Range	6 inch -48 inch
Compressed Height	35 inch
Extended Height	56.3 inch
Weight	11.6kgs
Max.Lifting Capacity	2000kg/4410lb
Fluid	Hydraulic Mineral Oil
Fluid Capacity	1200ml





[www.mojaboffroad.com](http://www.mojaboffroad.com)

Tel: +1(602)805-6812