



C25M - C25H - C25I - C25J - C25W

Preliminary Specifications

Hand pallet truck

2.5 tonnes





Hand pallet truck

The hand pallet truck is without any doubt the most basic, yet essential, tool in materials handling. For decades, it has served as the “first assistant” for truck operators loading and unloading pallets on location.

In warehouses, shops and industry, hand pallet trucks are used in all kinds of applications and are particularly suited to short distance and occasional horizontal pallet handling.

Cat hand pallet trucks are durable, maneuverable, ergonomic and easy to maintain over a long service life, taking care of your business and your people.

Find out how our range of hand pallet trucks could work for you

Your Cat Lift Trucks dealer can give you more specific information about the hand pallet truck and also our full range of warehouse equipment and lift trucks, with capacities up to 16 tonnes. They'll advise you on the right equipment for your needs and how to maximize your return on investment.

Characteristics			Cat Lift Trucks	Cat Lift Trucks	Cat Lift Trucks	Cat Lift Trucks	Cat Lift Trucks
1.1	Manufacturer (abbreviation)		C25M	C25H	C25I	C25J	C25W
1.2	Manufacturer's model designation		Pedestrian	Pedestrian	Pedestrian	Pedestrian	Pedestrian
1.4	Operator type: pedestrian, (operator)-standing, -seated		2500	2500	2500	2500	2500
1.5	Load capacity	Q (kg)	600	600	600	600	600
1.6	Load center distance	c (mm)	883	883	733	953	733
1.8	Load wheels axle to fork face (forks lowered)	x (mm)	1190	1190	1040	1260	1040
1.9	Wheelbase	y (mm)					
Weight							
2.1	Truck weight without nominal load	kg	62,5	67,5	66,5	72,5	60
Wheels, frame							
3.1	Tyre type: P=Polyurethane, N=Nylon, R=Rubber		P,N,R	P,N,R	P,N,R	P,N,R	P,N,R
3.2	Tyre dimension, drive side	Ø (mm)	200	200	200	200	200
3.3	Tyre dimension, load side	Ø (mm)	80	80	80	80	80
3.5	Number of wheels, load / drive side tandem / single		1/2x1 - 1/2x2	1/2x1 - 1/2x2	1/2x1 - 1/2x2	1/2x1 - 1/2x2	1/2x1 - 1/2x2
3.6	Track width (center of tyres), drive side	b10 (mm)	109	109	109	109	109
3.7	Track width (center of tyres), load side	b11 (mm)	370	370	370	370	370
Dimensions							
4.4	Lift height	h3 (mm)	115	115	115	115	115
4.9	Height of tiller arm / steering console (min./max.)	h14 (mm)	1214	1214	1214	1214	1214
4.15	Fork height fully lowered	h13 (mm)	85	85	85	85	85
4.19	Overall length	l1 (mm)	1543	1543	1393	1613	1393
4.20	Length to fork face	l2 (mm)	393	393	393	393	393
4.21	Overall width	b1/b2 (mm)	520	685	685	685	520
4.22	Fork dimensions (thickness, width and length)	s / e / l (mm)	53/160/1150	53/160/1150	53/160/1000	53/160/1220	53/160/1000
4.25	Outside width over forks (minimum / maximum)	b5 (mm)	520	685	685	685	520
4.32	Ground clearance at centre of wheelbase (forks lowered)	m2 (mm)	32	32	32	32	32
4.33/b	Working aisle width (Ast3) with 1000x1200 pallets, load crosswise	Ast3 (mm)	1743	1743	1683	1813	1683
4.34/b	Working aisle width (Ast3) with 800x1200 pallets, load lengthwise	Ast3 (mm)	1793	1793	1783	1813	1783
4.35	Turning circle radius	Wa (mm)	1276	1276	1216	1346	1216

Model	Fork dimensions WxL (mm)	Load wheels	Drive wheel
C25WPTP	520 x 1000	4 Tandem, Polyurethane	Polyurethane
C25MNTN	520 x 1150	4 Tandem, Nylon	Nylon
C25MPSP		2 Single, Polyurethane	Polyurethane
C25MPTP		4 Tandem, Polyurethane	
C25MRTP		4 Tandem, Polyurethane	Rubber
C25IPTP	685 x 1000	4 Tandem, Polyurethane	Polyurethane
C25HPTP	685 x 1150	4 Tandem, Polyurethane	Polyurethane

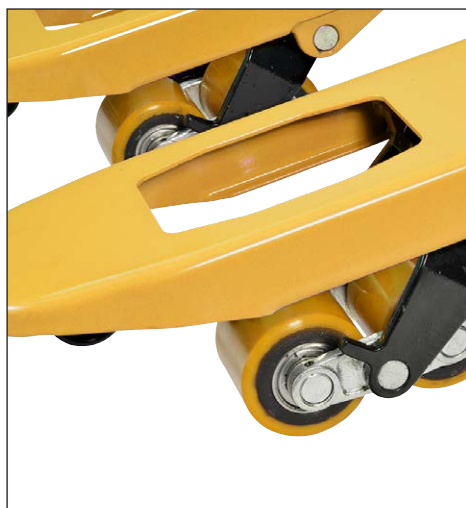

C25

Hand pallet truck

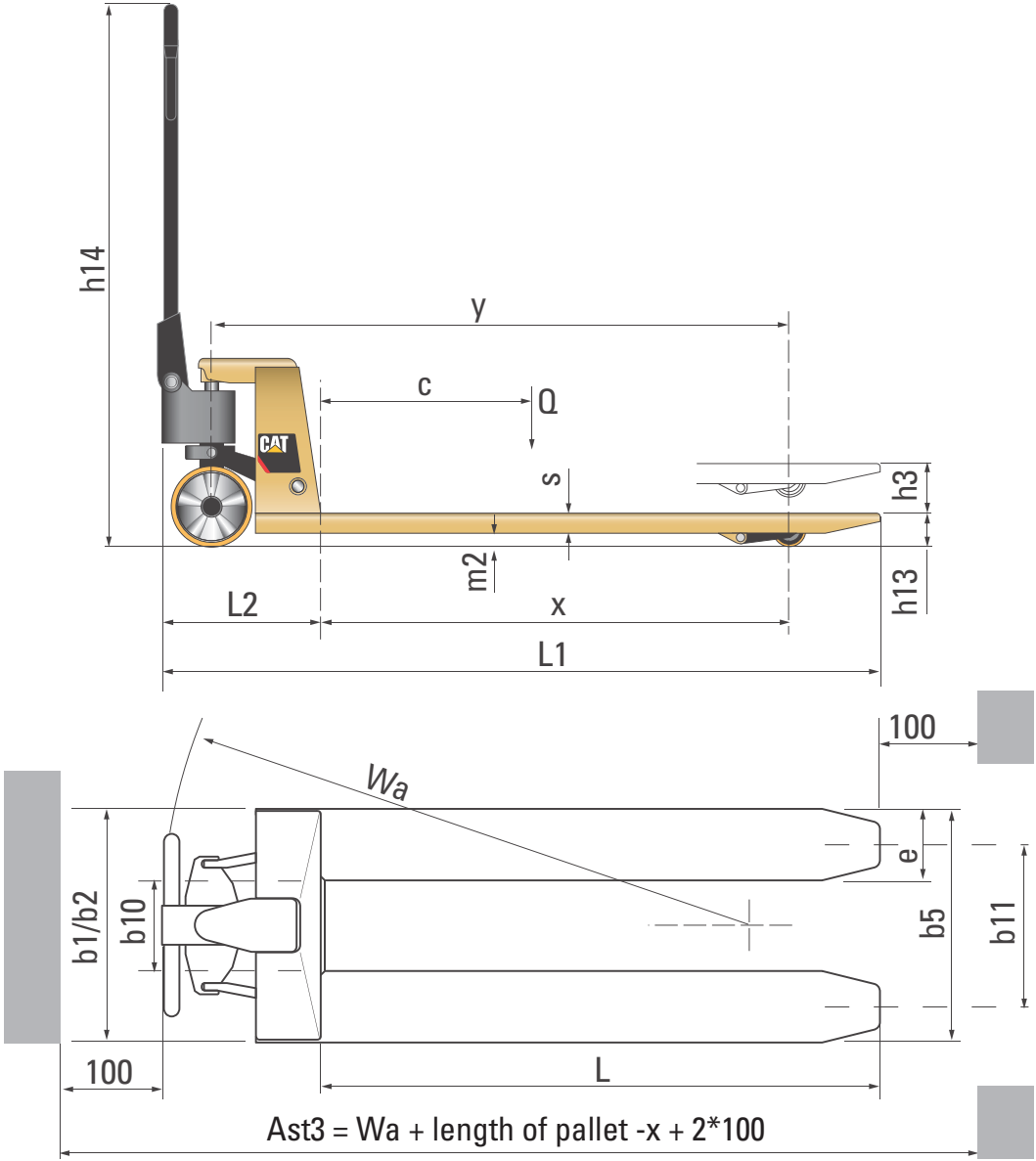



Hand pallet truck

Lower Cost of Ownership

- Competitive pricing
- Bypass valve preventing over load
- Bullet connection between steering shaft and pump piston
- Convenient to replace the steering wheel

Unmatched Productivity

- Easy to maneuver with 210° steering angle
- Special lowering valve to control the rate of descent
- Rollers mounted on fork tips for effortless entry/exit to/from pallet

Safety and Ergonomics

- Large rubber handle with 3 positions for control lever

Options

- Nylon, polyurethane- or rubber steering wheel
- Tandem load wheels

Cat® Lift Trucks.

Your partner in materials handling.



For over 80 years Caterpillar has built some of the world's best construction and mining equipment, designed to perform in the toughest environments.

This same philosophy and heritage is evident in our materials handling equipment, which includes a complete range of electric, diesel and LPG powered lift trucks and warehouse equipment.

Every day our dealer network delivers tailored materials handling solutions in more than 70 Countries across Europe, Africa and the Middle East.

We continually invest in the selection, development and support of our dealer network to provide you with the right equipment, service and advice. For instance, we offer the highest parts availability in the industry of over 97%, measured full line first pick, with next day delivery in most Countries.

Come and talk to us about your materials handling requirements.

Contact your dealer now or visit our website:

www.catliftruck.com

info@catliftruck.com
www.catliftruck.com

WEGC1834 (03/18)
©2018, MCFE. All rights reserved.
CAT, CATERPILLAR, BUILT FOR IT, their respective logos, "Caterpillar Yellow", the "Power Edge" trade dress as well as corporate and product identity used herein, are trademarks of Caterpillar and may not be used without permission.

Printed in The Netherlands

NOTE: Performance specifications may vary depending on standard manufacturing tolerances, vehicle condition, types of tyres, floor or surface conditions, applications, or operating environment. Trucks may be shown with non-standard options. Specific performance requirements and locally available configurations should be discussed with your Cat lift trucks Dealer. Cat Lift Trucks follows a policy of continual product improvement. For this reason, some materials, options and specifications could change without notice.

