

USE AND CARE GUIDE

ASTRA CFL AREA LIGHT

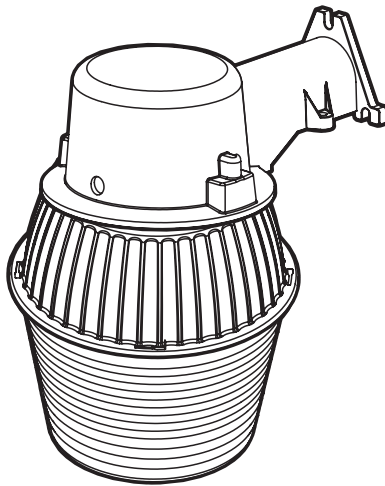

Questions, problems, missing parts? Before returning to the store,
call Commercial Electric Customer Service
9 a.m. - 5 p.m., EST, Monday - Friday

1-844-548-3776

HOMEDEPOT.COM

THANK YOU

We appreciate the trust and confidence you have placed in Commercial Electric through the purchase of this CFL area light. We strive to continually create quality products designed to enhance your home. Visit us online to see our full line of products available for your home improvement needs. Thank you for choosing Commercial Electric!

Table of Contents

Safety Information	2	Installation	5
Warranty.....	2	Operation.....	9
Pre-Installation.....	3	Care and Cleaning	9
Preparing for Installation	5	Troubleshooting	10

Safety Information

IMPORTANT

THIS PRODUCT MUST BE INSTALLED IN ACCORDANCE WITH THE APPLICABLE NATIONAL ELECTRICAL CODE AND LOCAL BUILDING CODES BY A PERSON FAMILIAR WITH THE CONSTRUCTION AND OPERATION OF THE PRODUCT AND THE HAZARDS INVOLVED.

PRECAUTIONS

- Please read and understand this entire manual before attempting to assemble, install, or operate this light fixture.
- This light fixture requires a 120 Volt AC power source.
- Some codes require installation by a qualified electrician.
- This light fixture must be properly grounded.
- Make sure connections are secure using wire nuts, crimp-on lugs or other UL approved connecting devices.
- This light fixture should be installed outdoors to a wall or a pole.
- This product may contain chemicals known to be hazardous. Thoroughly wash hands after installing, handling, cleaning or otherwise touching the product.



WARNING: Risk of fire. Keep the light fixtures at least 3 in. (76 mm) from combustible materials.



CAUTION: Burn hazard. Allow the light fixture to cool before touching.

NOTICE: Do not connect this fixture to a dimmer switch.

NOTICE: FCC Regulations state that any unauthorized changes or modifications to this equipment not expressly approved by the manufacturer could void the user's authorization to operate this equipment.



IMPORTANT: This equipment has been tested and found to comply with Part 18 of the FCC rules. This product may cause interference to radio equipment and should not be installed near maritime safety equipment operating between 0.45-30 MHz. However, there is no guarantee that interference will not occur in a particular installation. If this equipment does cause harmful interference to radio or television reception, which can be determined by turning the equipment OFF and ON, the user is encouraged to try to correct the interference by one or more of the following measures:

- Reorient or relocate the receiving antenna.
- Increase the separation between the equipment and receiver.
- Connect the equipment into an outlet on a circuit different from that to which the receiver is connected.
- Consult the dealer or an experienced radio/TV technician for help.



WARNING: Before installation or servicing, turn the power OFF at the circuit breaker or fuse. Place tape over the circuit breaker switch and verify power is OFF at the light fixture.

Warranty

This is a limited warranty offered by the manufacturer for a period of three years from the date of purchase to its customers. The manufacturer warrants to customers that the products will be free from defects in material and workmanship. The obligation of the manufacturer under this warranty is limited to the provision of replacement of products and is extended to the original purchaser of the product on presenting valid purchase receipt or other proof of date of original purchase acceptable to the manufacturer. The receipt is required for rendering the warranty performance. Any warranty claims without original proof of purchase would not be accepted.

It should be noted that the warranty does not apply to the manufacturer products that have been altered or repaired by unauthorized personnel, have been subjected to neglect, abuse, misuse or accident or damages caused during shipping. Any other products not manufactured by the manufacturer which have been supplied, installed and/or used in conjunction with the manufacturer products are not covered under this warranty. Any damages caused by replacements bulbs or corrosion or discoloration of brass components are also not covered by this warranty.

Warranty (continued)

LIMITATION OF LIABILITY

In no event shall the manufacturer be liable for indirect, consequential, incidental or special damages, or lost profits. The manufacturer is not liable for any claims or damage arising out of or connected with the manufacture, sale, delivery, use, maintenance and repair or modification of the manufacturer products, or supply of any replacement parts that exceed the purchase price of the manufacturer products giving rise to a claim. Labor charges to remove or install the fixtures will not be accepted.

TO CLAIM

Please contact The Home Depot customer service at 1-844-548-3776 or email support@homedepot.com and include your name, address and contact number, along with a copy of the purchase receipt and a brief description of the problem.

Pre-Installation

PLANNING INSTALLATION

Before installing the light fixture, ensure that all parts are present. Compare parts with the Hardware Included and Package Contents sections. If any part is missing or damaged, do not attempt to assemble, install, or operate this light fixture.

Estimated installation time: 20 minutes

SPECIFICATIONS

Lumens (Light Output)	2800 Lumens
Watts (Power Consumption)	65 Watts
Lumens/Watts (Efficacy)	43 Lumens per watt
Power Requirements (Input Voltage)	120VAC
Light Color (CCT)	4000 Kelvins (Bright White)
Dimmable	Non-Dimming (Do not wire to dimming switch)
Operating Modes	Dusk-to-Dawn: Automatically turns light fixture ON during night and OFF during day.

TOOLS REQUIRED



Phillips screwdriver



Wire strippers/cutters



Circuit tester



Silicone sealant



Wrench



Power Drill



Work gloves



Ladder



Safety goggles

Pre-Installation (continued)

HARDWARE INCLUDED



NOTE: Hardware not shown to actual size.

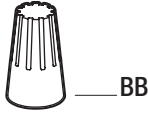

Part	Description	Quantity
AA	Hex head lag bolts	3
BB	Wire nut	3
CC	Rubber grommet	1
DD	Flat Washer	3

PACKAGE CONTENTS

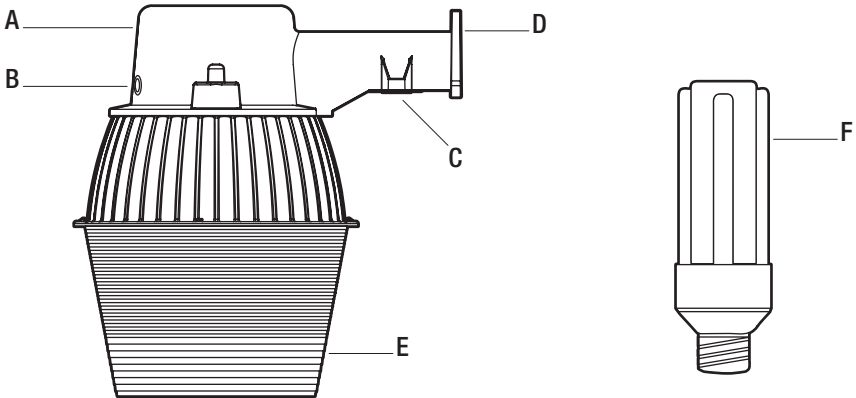

Part	Description	Quantity
A	Light fixture	1
B	Photocell lens	1
C	Wire cover plate	1
D	Fixture arm	1
E	Reflector	1
F	CFL Light (MXCFL65)	1

Preparing for Installation

Review this information to ensure a successful installation:

- Install the light 12–30 ft. above the ground.
- When mounting the fixture, ensure the photocell is in an area that receives daylight and is not too close to reflective surfaces in order to ensure successful Dusk-to-Dawn operation.
- When installing two fixtures on one switch, make sure the switch is rated for at least a 1A inductive load.
- Do NOT wire to a dimming switch.
- When mounting to a wall, make sure the fixture is 7 in. on center away from an eave and 13 in. on center away from the inside corner of the exterior wall.

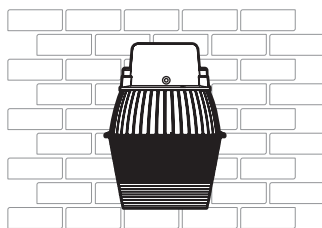

Wall Mount

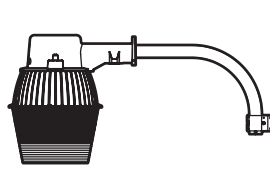

Extension Arm Mount

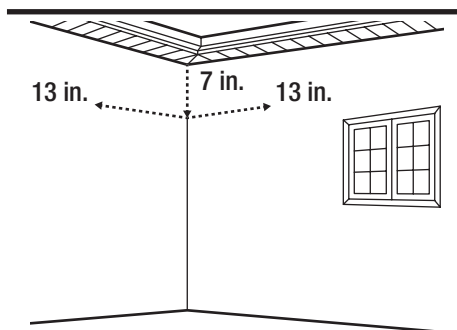

Installation

1 Turning off the electricity

- Verify the wall switch is in the OFF position.
- Turn off power at the circuit breaker that supplies power to the outlet box you are working on.
- For screw-in type fuses unscrew the fuse that supplies power to the outlet box you are working on.

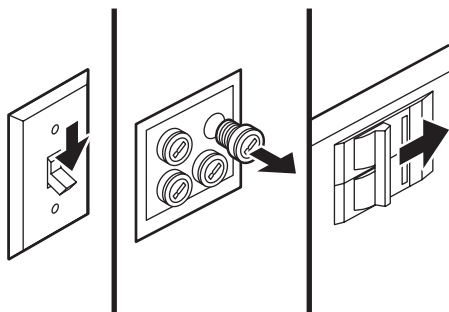

Installation (continued)

2 Preparing for mounting the fixture

Wall Mount



NOTE: The fixture comes with the wire guard protection plate (C) already installed on the fixture arm (D).

- Remove the wire guard protection plate (C) from the arm (D) of the fixture by loosening the screws.
- Mark and pre-drill the three holes on the desired location of the mounting surface.

Extension Arm Mount

- Remove the wire guard protection plate (C) from the arm (D) of the fixture by loosening the screws.

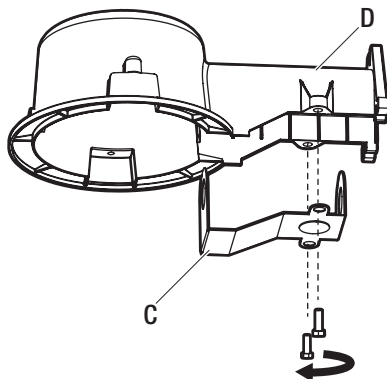

3 Mounting the fixture

- Feed supply wires through the arm (D).

Wall Mount

- Attach the fixture to the wall using the three hex head bolts (AA).



NOTE: Use other suitable bolts or fasteners as applicable to your mounting surface.



IMPORTANT: After marking and predrilling the three mounting holes, partially screw the bottom hex bolts (AA) and place the fixture's two bottom mounting grooves onto the bottom bolt (AA), then insert the top bolt, and tighten all bolts to firmly secure the fixture to the surface.



IMPORTANT: Please refer to the below table for using the correct hardware according to mounting surface material.

Mounting Surface	Hardware
Brick	1/4 in. Hex head sleeve anchor (not included)
Wood pole	1/4 in. Lag bolts (AA)
Masonry block	1/4 in. Toggle bolts (not included)
Metal wall panels	1/4 in. Bolt, nut, washers, and flat backing plate (not included)

Extension Arm Mount

- Secure the extension arm to the light fixture arm (D) using the screws removed earlier.



IMPORTANT: Extension Arm is available and sold separately. If you need to purchase the extension arm please contact your retail store. Installation instructions for the extension arm are available in the instructions sheet provided in the extension arm package.

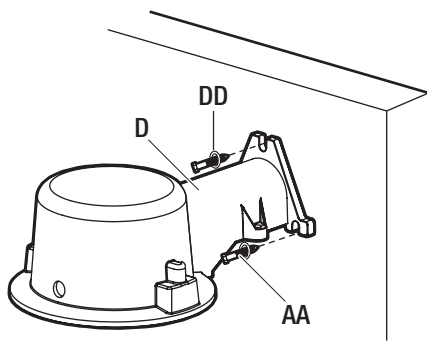

Wall Mount

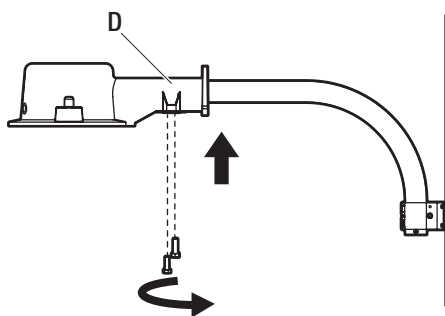

Extension Arm Mount

Installation (continued)

4 Making the electrical connections

Wall Mount

- Place rubber grommet (CC) into the hole of the wire cover plate before threading wires through.
- Thread the wires through the hole in the wire cover plate (C) before making wiring connections.

Wall and Extension Arm Mount

Electrical Wiring

- If necessary, strip 3/8 in. of insulation from the junction box or fixture (A) wires.
- Connect the fixture black wire to the supply black wire ((+) line), and fixture white wire to the supply white wire (-) common by twisting the exposed wires together and using the wire nuts (BB). Ensure there are no loose wires.
- Connect the supply green ground wire to the 2 green fixture ground wires by twisting the exposed wires together and using the wire nuts (BB).

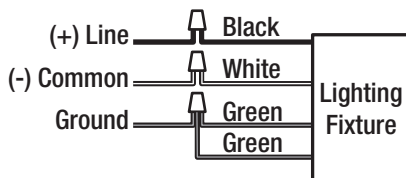
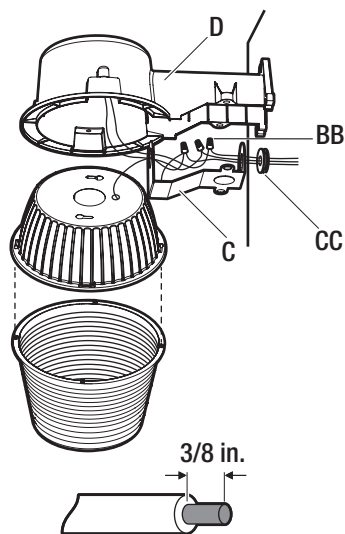

NOTE: Hold stripped ends near each other and align any frayed strands (do not twist wires).

Push the wires into wire nut (BB) and use your fingers to twist the wire nut clockwise until tight. Check for tightness by pulling wires.

5 Securing the fixture and wiring

Wall Mount

- Once the fixture is wired, place the wire cover plate (C) on the arm (D) by tightening the two screws removed earlier.

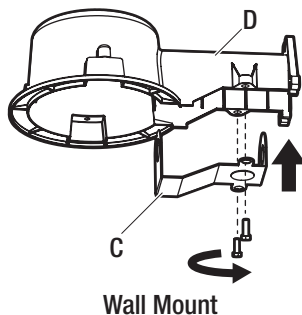

Extension Arm Mount

- After wiring is complete, secure the fixture on the extension arm by tightening the screws removed earlier.

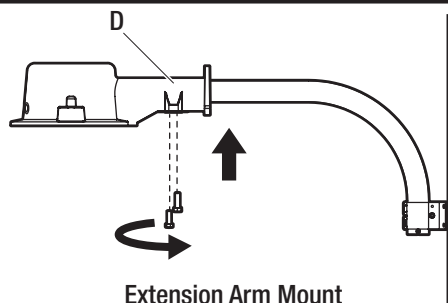

Installation (continued)

6 Installing the reflector

Preparing the reflector for installation

- Place the hooks from the bottom part of the lens reflector (E) into the holes provided in the upper part of the reflector's (E) rim and twist the bottom lens to fit.
- Close the hooks by pressing them down to lock.

Attaching the reflector to the fixture

- Install two small screws included with the reflector (E) leaving about 1/4 in. of space under the fixture head (A).
- Align keyholes in the reflector (E) with screw heads and rotate counterclockwise.
- Tighten the screws using a Phillips head screwdriver to attach the reflector (E) on the fixture head (A).



CAUTION: Be careful of sharp edges when installing the reflector and lens.

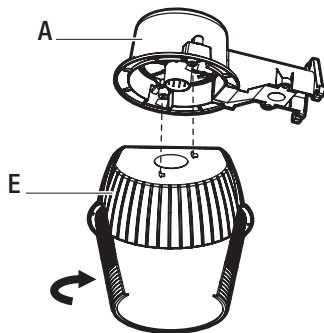
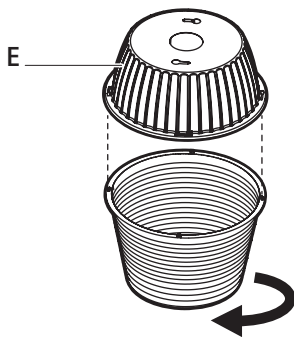

7 Installing the CFL light

- Install the CFL light (F) inside the reflector (E) on the fixture head (A).



NOTE: Only use MXCFL65 (provided in the box) for installation.

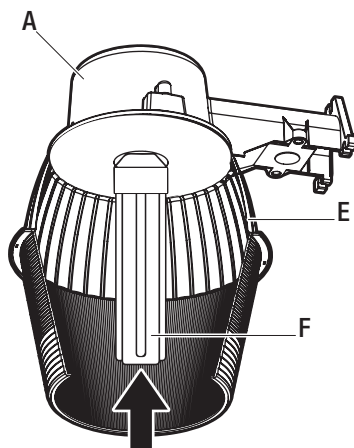

Operation

DUSK-TO-DAWN OPERATION

Dusk-to-dawn operation enables the light fixture to automatically turn ON when dark outside and turn OFF when the sun rises, thus saving you energy.

- To allow normal dusk-to-dawn operation ensure the photocell (B) is unobstructed.
- Ensure the switch powering the outlet connected to the light fixture is turned to the ON position and leave it ON at all times to enable dusk-to-dawn functionality to operate automatically.



IMPORTANT: To test if the light fixture (A) and photocell (B) works properly run power to the fixture and cover the photocell to turn the fixture ON. Shine a light into the photocell to see if fixture turns OFF.



NOTE: If the photocell (B) is located in an area under heavy shade the photocell may not detect enough light and may turn the light fixture on.

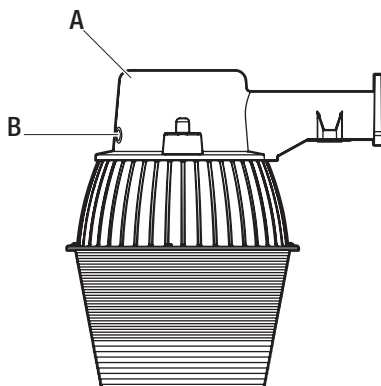

Care and Cleaning

- Shut off the main power supply before cleaning the product. To prolong the original appearance, clean the light fixture with clear water and a soft, damp cloth only.
- Do not use abrasive cleaners or cleaners that contain alcohol. Do not apply paints, solvents, or any other chemicals on this light fixture. They could cause a premature deterioration of the finish and may void the warranty.
- Do not spray the light fixture with a hose or power washer.

Troubleshooting

Problem	Possible Cause	Solution
The light does not turn ON.	There is no power to the fixture.	<ul style="list-style-type: none"><input type="checkbox"/> Check if circuit breaker is tripped.<input type="checkbox"/> Confirm wall switch is ON. Verify wiring to the fixture is correct (turn power OFF to fixture beforehand).
	The fixture senses daylight.	Cover the photocell. Wait several seconds until the fixture turns ON.
The light cycles ON and OFF continuously.	The photocell light sensor is sensing reflected light	Relocate the light fixture to a location where there is no reflected light.
The light flickers.	The light fixture is wired through a dimmer switch.	Do not use a dimmer switch to control the light fixture. Replace the dimmer with a standard ON/OFF switch.
The light stays ON.	The light sensor is in a shaded area.	Shine a flashlight into the light sensor and wait up to a minute. If the light turns OFF, the fixture should be moved to a location with enough light in the daylight hours for the light sensor to work.
	The light sensor is faulty.	If the light does not turn OFF when a flashlight is shined on the light sensor for up to a minute, then the sensor may be faulty. Please contact customer service.



NOTE: The photocell (B) may have a short delay in order to reduce its sensitivity to sudden light changes. When testing, shine a light/cover the photocell for up to a minute to check if the fixture functions properly.



**Questions, problems, missing parts? Before returning to the store,
call Commercial Electric Customer Service
9 a.m. - 5 p.m., EST, Monday-Friday**

1-844-548-3776

HOMEDEPOT.COM

Retain this manual for future use.