

Conventional Wainscot

Wall Padding Panels

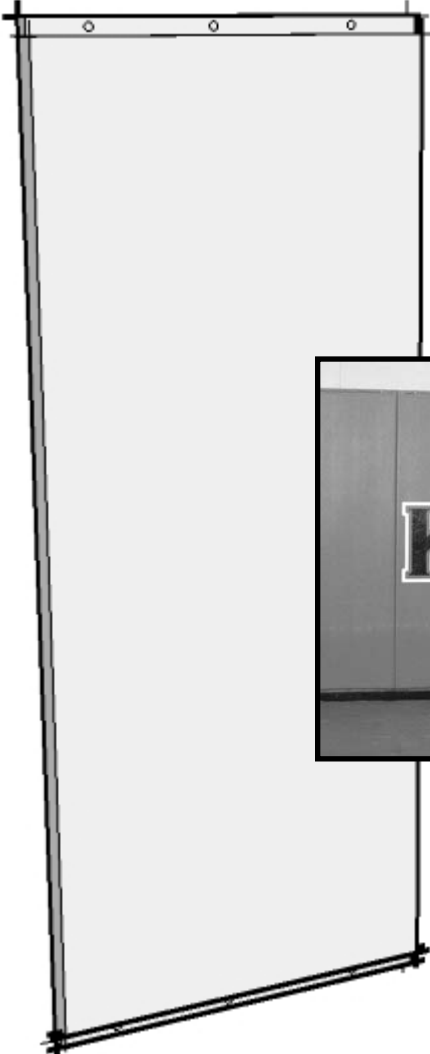

MODEL #
RWC25321
RWC26321
RWC253X1
RWC263X1
RWC25321
RWC25XXX
RWC26XXX



Installation Instructions

FOR CONVENTIONAL PANELS

Wainscot Wall Padding Installation

Thank you for purchasing Wainscot Panels from Resilite. Please read the instructions completely prior to beginning installation. It is important to pre-plan the exact location of each panel to be installed. Carefully determine where wall elements such as electrical outlets, fire alarms, thermostats, etc. will fall and if they will interfere in the placement of your panels. Resilite recommends that panels are installed not more than 4" above the floor surface. Step-by-step Instructions to create cut-outs around electrical outlets, etc. are also provided. Should you have any questions, or need technical assistance please call 1-800-THE-MATS (1-800-843-6287).

(NOTE: These instructions are provided as a guideline to assist you during the installation process. Careful attention to detail and these instructions will enable fast and easy attachment of your new wainscot wall padding. These instructions include directions for installing **CONVENTIONAL** wainscot panels.)

CONVENTIONAL Wainscot Panels:

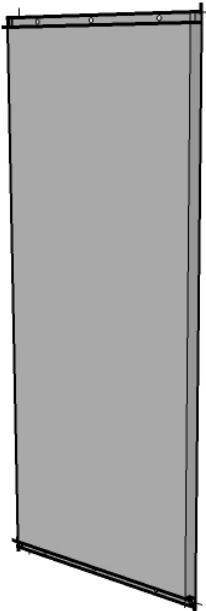

YOU WILL NEED TWO PEOPLE AND THE FOLLOWING TOOLS:

- Pencil
- Level or Framing Square
- Chalk line
- Tape Measure
- Electric or Cordless Drill
- $\frac{3}{16}$ " masonry drill bit
- P-3 phillips head driver bit
- Safety Glasses
- Saber Saw or Circular Saw
- 1" x 3" x 8' Furring Strips
- 2" Drywall or Tapcon Screws to attach furring strips
- 4d - 1" long finish nails
- 6 per panel - No. 10 x 1" flat head wood screws

STEP 1

Measure up from floor 4" and mark your wall. Give yourself two or three marks along the bottom of the wall. Using your chalk line strike a horizontal line to indicate the bottom positioning of the wall panel.

Using that line as a guide, measure up the wall exactly 62" for 2' x 5' panels or 74" for 2' x 6' panels. Strike another horizontal chalk line. You now have the top and bottom location of your wainscot panels.

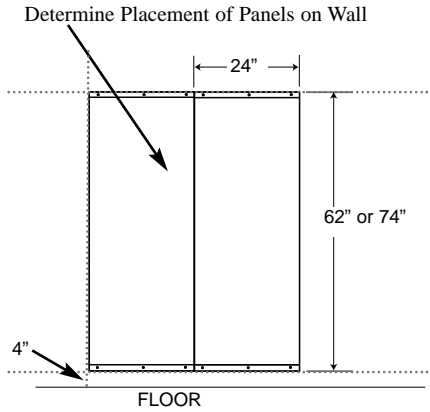

STEP 2

Mark the starting point for your wall padding. Using your square and a level, draw a vertical line 90° connecting your top and bottom lines. This will be the starting edge of your panel.

STEP 3

Determine if you can directly mount your panels onto the wall or if you will need to install furring strips to use as "nailers" to securely attach your panels.

NOTE: Each panel must be securely fastened to the wall on top, bottom and middle. If you will be directly mounting your panels to the wall it is recommended that a high-quality construction adhesive be used behind each panel. Failure to securely attach each panel to the wall could result in serious injury or death. It is generally recommended that furring strips be used when mounting conventional wainscot panels.

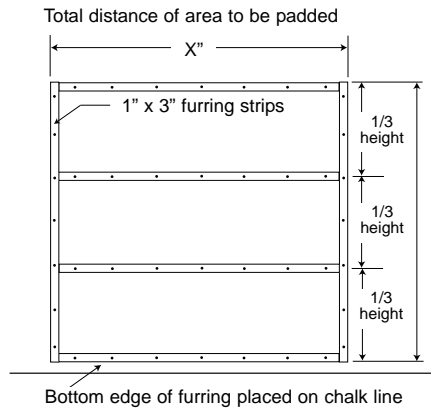

STEP 4

Using the top edge of the 1" "panel nailing flange" as a guide, align the panel flush with the top edge of the furring strip. Hold the panel in place, square and plumb the panel.

Attach the panel using three (3) No. 10 x 1" flat head wood screws through top flange and three (3) screws through bottom flange.

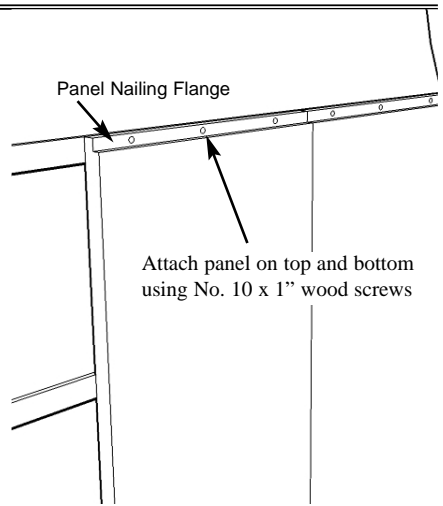

STEP 5

To ensure panels stay flat and secure to furring strips toenail a finishing nail where the panel laps-over the middle two furring strips. Use a 4d 1" long finish nail. ***Do not nail through the face of the panel.***

You will be able to nail both sides of your starting panel. All other panels will be nailed on one side only.

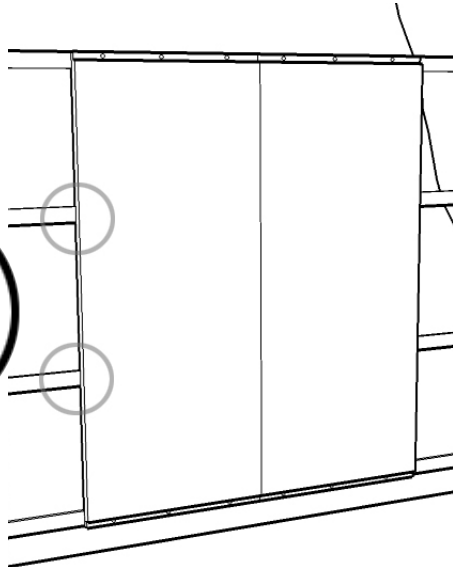
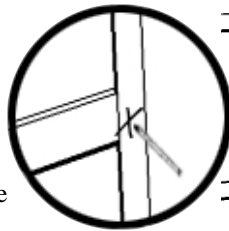

STEP 6

Continue attaching panels until all panels have been installed.

HOW TO MAKE CORNERS

INSIDE CORNERS:

Inside corners can easily be made by creating a “butt joint”.

STEP 1: Install one panel completely into the corner, if possible.

STEP 2: Pad the other wall that joins the corner. Work from the outside of the wall toward the corner. Once you have reached close to the corner, measure the distance between the last pad installed and the pad that is butted into the corner. This will be the space to be filled by cutting down one pad.

STEP 3: Select pad to be cut down. Mark distance to be padded on back of panel.

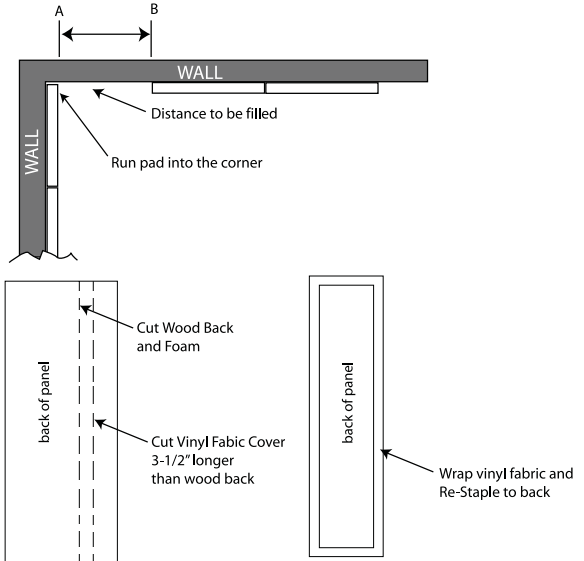

Strike a chalkline from top to bottom. Remove the staples from the top, bottom and one side of the pad.

STEP 4: Double check measurements. Using circular saw set depth of cut to be approx. 3/8". Cut through plywood only along entire length of panel, using the chalk line as your guide. With sharp knife, trim the foam back to the edge of the plywood. BE CAREFUL NOT TO CUT VINYL FABRIC.

STEP 5: Cut the vinyl fabric 3-1/2" wider than the edge of the plywood. This will provide you with a new “tack strip”. Wrap the vinyl around the panel and onto the back. Begin stapling along the side, then staple top and bottom.

STEP 6: Your panel should now fit the space needed between your last panel and the corner panel.

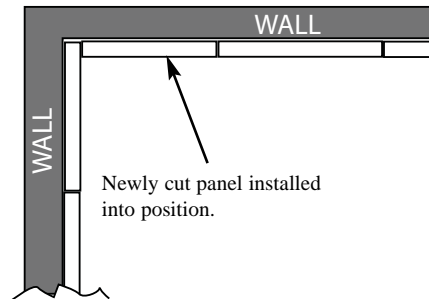

HOW TO MAKE CORNERS

OUTSIDE CORNERS:

Outside corners can be made by removing some of the wood back and folding the panel around the corner.

STEP 1: Hold the panel into position and mark off LINE “A” on the back of the panel.

STEP 2: Lay the panel flat with the back facing up. Measure out 2” from Line “A”. Mark Line “B”.

STEP 3: Strike a chalk line from top to bottom along both line “A” and “B”. (figure: 1)

STEP 4: Double check measurements. Using circular saw set depth of cut to be approx. $\frac{3}{8}$ ". Cut through plywood only along entire length of panel, using the chalk line as your guide.
BE CAREFUL NOT TO CUT INTO THE FOAM.

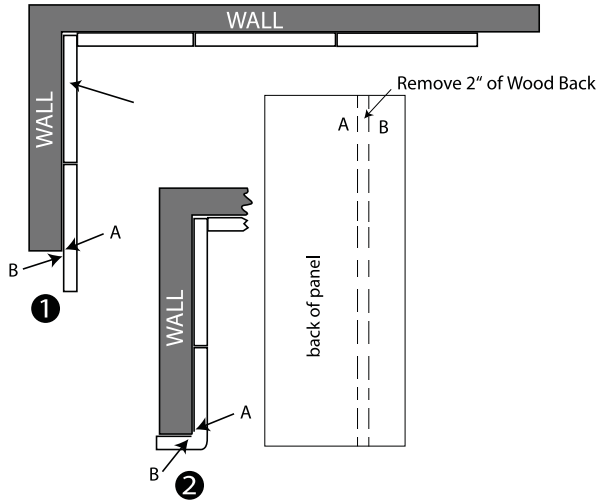

STEP 5: Remove plywood between “A” and “B”.

STEP 6: Place your panel into position. Gently fold around the corner and attach panel as normal. (figure: 2)

NOTE: For safety reasons, never make a “butt joint” at an outside corner.

CUSTOMIZED PADS

Resilite offers a variety of customized “L”-shaped corner pads, “I-Beam pads and “U”-shaped column pads. These pads offer you a quick and easy way to get a professional-looking installation. Resilite can also create irregular column pads to cover almost any obstruction. Accurate dimensions of the obstruction you wish to pad must be provided to Resilite.

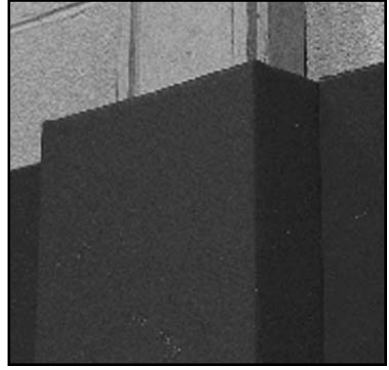

INSTALLING “L” or “U” SHAPED PADS

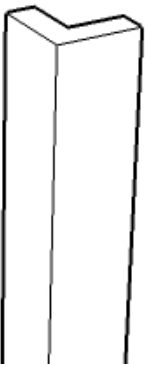

“L” Shaped Pad



“U” Shaped Pad

If ordered, Resilite may have provided you with factory-made “L” Shaped or “U” Shaped customized pads. These pads should be installed before the pads on either side of the obstruction.

STEP 1: Hold the panel into position and fasten to wall or furring strips using the “nailing flange”.

STEP 2: Butt your wall panel to the “L” or “U” shaped pad.

CUTOUTS

Resilite has provided a separate document with step-by-step photos for making simple cutouts. Follow the instructions provided for professional-looking cutouts. If you have any questions regarding the installation of your panels please call 1-800-THE-MATS.





PO Box 764, Sunbury PA 17801

Call Toll Free: **1-800-THE-MATS** or **1-800-843-6287**

Fax: (570) 473-8988 • E-mail: resilite@resilite.com

Web Site: www.resilite.com