



15 MINUTES

Contact Information

CONGRATULATIONS on your ProSun® purchase!



Please make sure you read this manual carefully before using this equipment and specifically the maintenance schedule. If you have any questions please contact ProSun directly.

ProSun International LLC

2442 23rd Street North
Saint Petersburg FL 33713
Toll Free: (800) 874-2776
Telephone: (727)825-0400
Fax: (727) 825-0700

For all customer service related questions please contact our service department.

Toll Free: (800) 501-8485



WARNING!



WARNING!

ProSun has drawn up a maintenance schedule to ensure good performance and maximum life of your unit. It is strongly recommended to adhere to these service instructions and intervals. Always disconnect the power before starting any maintenance work or cleaning!!

Read all the instructions thoroughly, failure to do so may result in:

- Serious death or injury
- Damage to the device or environment



WARNING!

WARNING: No modification of this equipment is allowed.

For the safety of yourself and others around you please read all the following instructions thoroughly. Please allow all operators of this equipment to read these instructions.

COPYRIGHT

ProSun International LLC

The contents may not be duplicated (in whole or part), distributed or utilized for competitive purposes without authorization or disclosed to other parties. Changes cannot be made to the information herein.

Table of Contents

Important Customer Information	5
Who Should Use, Read, & Understand this Manual	5
Warning Signs & Symbols	5
Preparing the Product For Use	7
Export	7
Transportation	8
Delivery	8
Ventilation	8
Installation & Set-up	8
Environmental Conditions for Transport & Storage	8
Environmental Conditions for Operation.....	8
Comissioning of the Equipment	10
Equipment Components & Description	10
Device Description	10
Lamp Configuration	11
Dimensions	11
Technical Data	12
Electrical Specifications	12
Electrical Requirements	13
Electrical Connections	14
Before Your Red Light Session	15
After the Red Light Session	16
Operation of the Equipment	17

How to Operate the Equipment	18
Normal Equipment Operation	18
Storing the Device	22
Decommissioning Your Unit	22
Storage	22
Disposal	22
Control Functions	23
General Operation	24
Error Messages	26
Care & Maintenance	27
Basic Care Maintenance	28
Maintenance Schedule	28
Cleaning & Disinfecting Acrylics	29
Cleaning Plastic Surfaces	30
Cleaning Lamps	30
Cleaning the Machine	30
Maintenance by Skilled Persons	30
Troubleshooting Guide	31
Replacement Components	32
Longevity of Acrylics	32
Longevity of Lamps	32
Disposal of Lamps	32
Technical Modifications	32
Removing Acrylics	33
Replacing the Lamps	34
Assembly Introduction	35
Included Parts	36
Assembly	37
Warranty	45

Important Customer Information

Who should use, read and understand this manual:

- Owners - Owners are people that have this equipment in their business and have read and fully understood this whole user manual. The owner is responsible for ensuring that any other person who uses this equipment has also read and understood this user manual and labeling on the equipment.
- Operator/User - People who are responsible for the operation, cleaning as well as general maintenance care, as outlined in this manual, and who instruct the patients in the operation of the equipment. All operators have fully read and understood this user manual and labeling on the equipment.
- Patient - Any person that receives a session.
- Service technicians- Certified technicians who will perform assembly and maintenance work on the equipment and have fully read and understood the user manual and labeling on the equipment.

All people that will be operating this equipment need to fully read and understand these instructions and all labeling on the equipment. A copy of the user manual should be readily available. This manual may include features that are not included for your bed. Any service work outside of the preventative care table in this manual should be done by a ProSun authorized technician.

Warning signs and symbols

Danger and Safety Symbols:



DANGER!

Danger Hazard exists for human health.



WARNING!

WARNING: Hazard exists that can be dangerous to human health if instructions are not followed properly.



WARNING : To avoid risk of electric shock, this equipment must only be connected to a supply mains with protective earth.

High Voltage exists and is dangerous for human contact.



Caution Symbol means to proceed with caution and follow instructions carefully.



ESD-Sensitive devices, do not touch without using necessary proper precautions.

Symbols found on equipment and packaging:



Follow and read instructions thoroughly prior to using equipment.



Keep equipment dry.



Fragile.



This way up.



Use only long forks on the fork lift and only lift on the correct openings.



Do not double stack. This symbol indicates that the items shall not be vertically stacked, either because of the nature of the transport packaging or because of the nature of the items



Temperature limit indicates the maximum and minimum temperature limits at which the item shall be stored, transported or used.



Atmospheric pressure limitation. This symbol is accompanied by the upper and lower limits of atmospheric pressure for storage and transportation.



Humidity limitation indicates the acceptable upper and lower limits of relative humidity for transport and storage.



Protective earth connections.



Recyclable Material



Polystyrene



Cardboard



Mixed Paper



Wood



Waste of electrical and electronic equipment must not be disposed as unsorted municipal waste. It must be collected separately, and must be disposed as per local regulations.



Alternating Current. Single Phase

Preparing the Product for Use

Export:

The device in this manual is intended for use in the United States and Canada. If this equipment is exported to other countries, other standards may apply and not all information in the operator manual may be applicable. ProSun does not assume any liability if there is non-compliance outside of the intended sale territories of the United States or Canada. The exporter assumes their own risk by removing this equipment outside of the United States or Canada.

Transportation:

- Equipment must be transported on the pallet on which it is mounted, and should not be double stacked with other transport materials. If a forklift is used the long forks should be used and only from the correct side. Only lift the load a few centimeters and move it to the place of installation.

CAUTION - If the short forks are used damage may occur. 

If a forklift cannot be used then the device must be partially disassembled from the pallet for transport. Installers or persons transporting the equipment may want to use a dolly to move the disassembled components but be careful of the weight. Each piece should be moved individually to the place of installation.

During transportation environmental conditions must be met, ambient an ambient temperature range of - 40 °C to + 70 °C or -40°F to 158°F, relative humidity range of between 10 to 95% including condensation and atmospheric pressure range of 50 kPa to 106 kPa.

If ambient temperature change is different from required temperature then let equipment sit at proper temperature for at least 2 hours prior to installation.

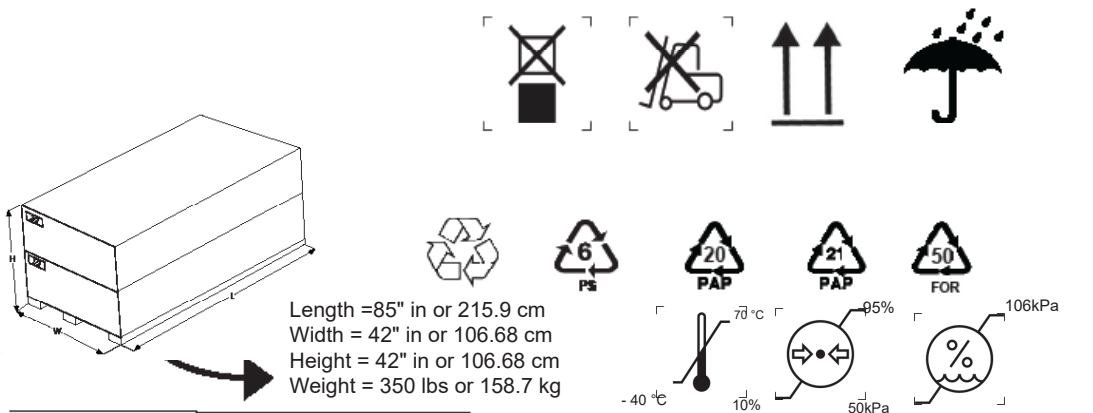

Length = 85" in or 215.9 cm
Width = 42" in or 106.68 cm
Height = 42" in or 106.68 cm
Weight = 350 lbs or 158.7 kg

Icons: No stacking, Forklift (long forks), Upward arrows, Umbrella, Recycle, PS 6, PAP 20, PAP 21, FOR 50, Temperature range (-40°C to 70°C), Humidity (10% to 95%), Pressure (50kPa to 106kPa).

ProSun international LLC

Delivery:

Once equipment is delivered make sure proper temperatures, humidity and atmospheric pressure are in place.

The following items are included in the delivery:

- Equipment
- Protective goggles
- Cleaner
- All parts in assembly manual
- Instructions on downloading the User Manual

Note that equipment is delivered through third party freight company. Equipment will not be brought inside the building by freight company unless prior arrangements are made. Coordinate with ProSun installation department to set up delivery and installation details.



In a commercial setting an external timer is required. ProSun recommends to use this accessory (T-Max Flushmount G2).



DANGER!

Ventillation:

The Device must always have proper ventilation. Failure to do so can cause in serious safety hazards and overheating of the equipment.

Installation and Set-up:

Equipment should only be installed in dry rooms with proper ventilation and airing. The room should be the recommended size of 8 x 7 ft in order to allow for good air flow.

The unit should not be set up in a mobile environment or facility, i.e. trains, buses, ships. The unit also should not be used outdoors, if used outdoors damage to the equipment is possible and the manufacturer will not be held liable

Before starting the installation process or operating the equipment the transportation pallet should be removed. Observe correct room sizes prior to installation the equipment and ensure that room has correct electrical specifications. The customer must have provided a dedicated power source when called for in the technical specifications of the unit.

Environmental conditions for transport and storage:

- Relative humidity range of 10% to 95% including condensation.
- Atmospheric pressure range of 50kPa to 106 kPa.
- Storage temperature range: -40 °F (-40 °C) and 158 °F (70 °C)
 - Let equipment sit for at least 2 hours if range was outside of ambient temperature range.

Environmental conditions for operation:

- Relative humidity range of 30% to 75% including condensation.
- Atmospheric pressure range of 50kPa to 106 kPa.
- Optimum ambient temperature range: 50°F (10°C) and 86 °F (30°C)



Installation can present a Danger with electrical shock or burns, only authorized personnel should install the equipment. Initial installation in commercial settings should be done by a ProSun certified technician. As the equipment owner it is your responsibility to ensure that correct electrical requirements are met and followed.

Overheating can occur if proper ventilation is not followed. Never obstruct the airways in the inflow and outflow areas. If proper ventilation is not followed system malfunction and damage may occur. Always install the unit at proper distance from walls in order to have proper airflow. Failure to do so may cause system failures or errors.

The customer is responsible for all costs associated with the preparation of the installation of the equipment. This includes but is not limited to room preparation, costs, fees, permits, and inspections unless specified otherwise in the sales order for the equipment purchased. ProSun and all authorized parties shall reserve the right to refuse to install equipment into any room which has not been properly prepared in accordance with the electrical specification and room requirements.

The electrical contractor or his designee shall provide and install all electrical material as specified for a safe operating system. ProSun certified technicians will not perform any electrical work. The recommended electrical plan must be coordinated between the customer and the electrical contractor. Any deviation of the electrical, before, during and after equipment installation is the responsibility of the customer. The electrical contractor or his designee shall ensure the completion of all electrical requirements prior to the installation of any ProSun equipment. All wires shall be single solid runs without splices, meeting NEMA standards. The electrical contractor or his designee should ring out, tag and terminate all wires at both ends. Each should be inspected to ensure that no wires have been grounded or are left open. ProSun certified technicians are not responsible for the final installation of the electrical system, the electrical contractor or his designee should be present to make the final electrical connection upon completion of the installation of the equipment.

The customer shall bear the sole responsibility for compliance with all applicable codes, OSHA, NEMA, local and national Standards. All electrical work shall conform to the requirements of the national electrical code, OSHA or applicable local and or state ordinances.



WARNING: Position the equipment so that disconnection to the mains plug can be easily made during the unexpected error which could lead to a hazardous situation.



WARNING: Power supply cord must be replaced by ProSun certified technician.

Commissioning of the equipment

The equipment is initially commissioned by a certified ProSun technician. The device will be properly assembled and handed over ready for us. In order to properly commission the equipment, the business owner must ensure that the location is ready prior to the equipment being installed. This included having correct power requirements and having the room in which the unit will be located ready.

If the equipment has not been used for a longer period of time, then it must first be inspected by a certified technician before being put back into operation again.

Device Description

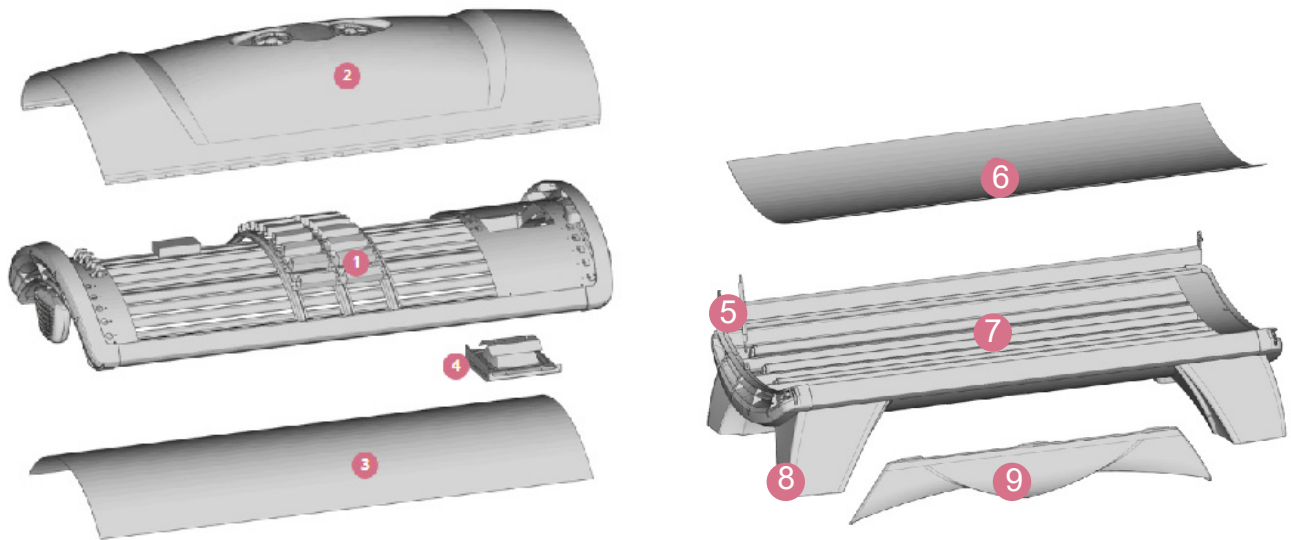

1. Ballasts - your unit may have different ballasts than shown in image
2. Canopy cover plate
3. Canopy Acrylic
4. Not available for Jade models
5. Shocks
6. Bench Acrylic
7. Bench
8. Side Legs
9. Front Skirt (optional)

Lamp configuration- The use of non approved Lamps voids the warranty!



RenuvaSkin L32					
	Quantity	Name	Length	Watts	Part Number
A	18	RenuvaSkin 110W	75" inches	110W	LAMP8070030
B	14	RenuvaSkin 100W	71" inches	100W	LAMP8070020

RenuvaSkin L32 - Spare parts	
Acrylic Canopy	ACRY6012165
Acrylic Bench	ACRY6012180
Shocks	GASP6014349
Goggles	ACCE2501629

Dimensions

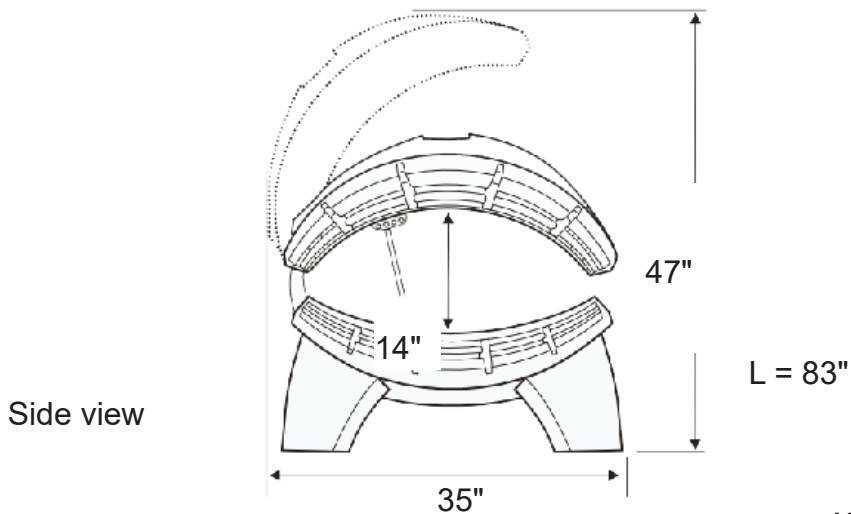

Technical Data

Electrical Specifications

RenuvaSkin L32	
RenuvaSkin L32	
Power consumption rating:	17 Amp
Rated Voltage:	120V ~ 17A 60Hz
Rated Fuses:	20 amp 1-pole
Continuous Operation:	Continuous operation for a maximum of 15 minutes.
Noise level inside the device:	71 
Noise level 1m away from the device:	62
Load on the base plate:	Max 250lbs or 113 Kg
Equipment Weight:	Approx 300 lb or 136 kg
Operating Humidity:	30-75%
Ambient Operating temperature:	50 to 86 degrees Farenheit 10 to 30 degrees Celcius
Max. operating altitude (above sea level):	<6500 ft (2000m)
Max surface temperature:	146.6 degrees Farenheit 63.7 degrees Celcius



Note: If operating this equipment at altitudes above 6500 ft / 2000m above sea level adaption may be needed to get normal operation.

Important Notice:

- Never operate this machine when the ambient room air temperature is greater than 104 degrees Fahrenheit. Never operate this machine when it is not ventilating itself properly (too hot inside).
- This device may not be used by people with reduced physical, sensory or mental capabilities or who have insufficient experience and/or knowledge without supervision. A person responsible for their safety must make sure, either by supervision or instruction, that the device is used correct and safely. If there is any doubt about the above mentioned instructions then that person cannot use this device.
- Never operate this machine when it is not ventilating itself properly (too hot inside).
- The salon owner or operator may never, under any circumstances, open the bench or canopy of the unit without the supervision of an authorized service person.

The Electrical requirements for your ProSun unit are:

Model	Breaker 1	Volt 1	Breaker 3	Volt 3	Hertz	Operating Amps 1	Operating Amps 3
ProSun Jade 32J	20 Amp	120V ~	N/A	N/A	60 Hz	17 Amp	N/A

Connecting a 120v unit to a 220V power source constitutes an automatic NULLIFICATION of the manufacturers factory warranty, because it could cause damage to the unit’s system.

Please insure that your electrician and/or installer, reads this user’s manual carefully prior to the installation of your ProSun unit. Service personnel should be authorized by ProSun to perform work on equipment and should have knowledge of equipment and read the full manual.



WARNING: Always disconnect the ProSun unit from its power supply when serving or repairing the unit.

WARNING: Plug is used as a means of isolation.

Electrical Connections



DANGER!

Live Components

Risk of fatal injury due to electrical shock when touching live parts.



WARNING!

Risk of electrical Shock

To avoid the risk of electrical shock, this equipment must only be connected to a supply mains with protective earth.

Both the power supply and the related connection work must comply with national standards. The connection work and replacement of the power supply cord must be done by a certified electrician or technician. For Canada a Class-A ground fault circuit (GFCI) has to be used. Any equipment outside of the US and Canada needs to comply to their countries standards.

Connection Requirements

There must be an emergency disconnect to turn off the unit in the room.

Before your Red Light Session

Check for any conditions mentioned in the manual that may prevent you from using the equipment.

Make-up and cosmetics

Do not wear make-up when using the equipment. Make-up clogs the pores in your face.

Jewelery

Remove all jewelery prior to use, including piercings.

Hair and loose items

Any loose hair should be tied back using a hair tie. Any loose items on clothing should be secured.

Medications

Some medications increase the skin's sensitivity. The probability is especially high with antibiotics, sulphonamids, psychiatric drugs, tranquilizers, anti-diabetes treatments and diuretics. Sun creams which contain psorale or kumarin also may increase skin sensitivity. If you are unsure consult your doctor prior to using the equipment!

Contact Lenses

You do not need to remove your contact lenses prior to using the device but you must like all other users wear the protective goggles.

Showering and hydrating the skin

We recomend treating your skin to a moisturizing cream after showering after your session.

After the Red Light Session

Cleaning and Disinfection

All parts of the equipment that come in contact with the user must be cleaned and disinfected after each session.

Infections can be transferred through skin contact. The following items should be cleaned after each session:

- Goggles
- base plate
- acrylics
- handles
- control panel
- Mp3 components
- Only approved bed cleaner should be used, such as Lucasol One step. Use of any incorrect bed cleaner will void the warranty. Use only EPA registered quaternary ammonium germicidal based detergent solution. Always follow the product label for dilution

Cleaning the machine:

Always disconnect the main power from the unit before attempting to clean or repair it.

Dust the lamps with a dry cloth - do not use cleaning fluid or alcohol. The acrylics should be taken out at least once every week of operation and cleaned thoroughly with a non-alcoholic disinfectant glass or surface cleaner. If alcohol is used, the acrylic may fade, crack, or break altogether. Use a vacuum cleaner with a dust nozzle to clean around the ballast racks and throughout the interior portions of the base, top deck, and bench.

Cleaning Acrylics:

Do Not clean or rub with a dry cloth as it may cause scratches!

Non-approved cleaning agents should not be used, especially products including lysoform, ethyl alcohol or other liquids containing alcohol. **If used the warranty will be voided!**

Acrylics should be cleaned after every use, even though they do not always come in direct contact with the user. If the user does touch the acrylic and those marks are left for a period of time, combined with the heat and light from the lamps those marks can become permanent.

Cleaning Plastic Surfaces:

For cleaning plastic surfaces we recommend using regular soap and warm water. Never use an aggressive cleaning agent that contains alcohol or essential oils. Using inappropriate cleaners may cause permanent damage not covered by warranty. Remove all jewelry and loose items before cleaning.

Cleaning Lamps:

Low pressure lamps can be cleaned with a damp cloth (without any additional cleaning agents). Dust lamps with a dry soft cloth - do not use cleaning fluid or alcohol.

Operation of Equipment

Obligations of the business operator

- As the business operator you are responsible for informing the user of the risks of use.
- All danger and safety labels should be attached to the equipment and clearly visible to the user. You should not remove these labels at any time!
- No safety devices(i.e. temperature sensors) may be removed, deactivated or otherwise bypassed from the equipment, as it can cause safety issues and impair the proper functioning of the equipment.
- The equipment may only be used when in proper operating conditions.
- It is the business operators responsibility to ensure the unit is handled properly.

Staff Training

As a business operator you are required to train your personnel by ensuring that they have read and understood this user manual and all labeling on the equipment, and can properly operate the equipment and instruct them in the established legal and accident prevention regulations. Ensure that your staff is properly trained and understand how to use the equipment and that they observe all these instructions. This includes:

- Information regarding intended use and foreseeable misuse of the equipment.
- Safety Instructions
- Operating Instructions
- Cleaning/Disinfection and maintenance instructions.

Please make sure the instructions and any additional information from the manufacturer, such as manuals, are available to the staff at their workplace.

Regularly check that your staff is conscious of the safety rules and are aware of the risks of improper use of this equipment.

Ensure that equipment is properly cleaned/disinfected per the intervals set forth in the manual.

Ensure that your staff is providing the users with proper advice, in particular regarding the exposure times, operation of the equipment and possible risks for misuse.

How to operate the equipment

Prior to operating the equipment check that the unit has been cleaned/disinfected and check for any damage to the acrylics.

No other people should be in the vicinity of the equipment when in use. This device should be used by 1 person at the time.

Lay down facing up towards the controls. When the session is finished do not push up on the acrylic but rather open the canopy by lifting on the side of the unit.

Equipment Operation

Before turning on the equipment make sure you have proper warning signs at your location. We recommend permanently placing a Warning sign on the wall close to the bed such as the one below:

Operating Modes:

There are 4 different operating modes for this equipment.

Standby Mode

The bed is in an idle state, it is connected to the power but is currently not in use. The lamps in the unit are not turned on at this time. While in Standby mode you can change to In Use mode by starting a session or go into service mode by entering into the parameters.

In Use Mode

The bed is in use and the lamps are on. The session time is counting down and can be stopped, paused or features can be changed in the control panel.

Cool down Mode

The bed has finished the session and now will start a mandatory cool down. During this time the cool down time will be displayed in the control panel and the buttons have no function if pressed. The bed must complete the mandatory cool down before being able to enter into any other operating mode.

Service Mode

In service mode the bed parameters can be changed and the bed can be configured as needed.

Starting the session

Press start once on the START button on the display. You will see the maximum minute time, here you will use the minus button to select the desired minutes for your session. Then press START again to turn on your session. If you do not push a button quickly enough the display will go blank and you will need to start this process again.

Before entering the bed prepare yourself for the session.

- Remove all clothes and jewelery
- Remove make-up and cosmetics
- Put on lotions(if applicable)
- Remove glasses, contacts can be worn under goggles.
- Put on protective goggles.
- Close the device
- Lay down in the unit facing up towards the display
- When the session is over do not push up on the acrylic but rather put your hand outside the unit and push the canopy open.

Operation during the session

During the session the features can be used by pushing the buttons on the control panel. You can push the feature you wish to use (i.e. the fan button followed by the increase button or decrease button.

Note: 20 seconds after your last input the control display screen will go back to the session time. You can change the features at any time by pushing the button of the feature you wish to activate.

Stopping the Session

If the time in the session runs out naturally then the unit will go into a 3 minute cool-down. However if you need to stop the session prior to end of the session you can do so by hitting the START/STOP Button.

To pause the session you can hit the START/STOP button once.

Then to completely stop the session prior to the end of our session time hit the START/STOP button twice and the unit will go into Cool-down mode.

Standby Mode

When the unit is in standby mode, you can change the decorative lighting on the device.



This symbol will appear on the LCD display after 500 hours. It is preferable after 800 hours to replace the lamps with new ones. After replacing the lamps reset the lamp hour counter.

Note: The exposure label on the front of the unit shows the lamps that are suitable for your unit.

Reading Hour Counter:

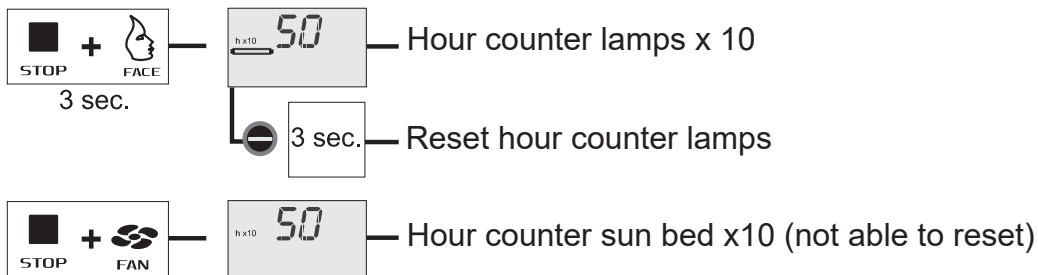

Service Mode

When the unit is in standby mode, you can enter into the service or maintenance parameters.

To Program your Unit Display



Note: Start with a Blank Display

Step 1: Enter into Program mode by Pushing B and D simultaneously for 10-30 seconds or until the display shows a 01. Let go and the display will blink 01 and a number.

If the display shows 01 and 00 - the unit is in external timer (T-Max mode)

If the display shows 01 and a number - the unit is in stand alone mode.

Step 2: To put the unit in Stand Alone Mode: when the display shows 01 and 00, use the Plus (D) button and increase the time to the maximum exposure time. Then hit the Start (A) button to save. If the unit is in stand alone mode reverse these steps using the Minus button (C) to put the time on 00, then hit start.

If the screen goes blank before hitting the Start button to save then the parameters did not save. Start the process over with Step 1.

Storing the Device

Decommissioning your unit

The equipment must be disconnected from the power in order to temporarily or permanently decommission it. You must follow legal disposal requirements when you are going to permanently dispose of your unit.

Storage

Store the equipment in a dry, frost free location with a stable temperature. Once the device has been unplugged from the power supply, allow it to completely cool before packaging it for storage. You can use plastic wrapping to protect against scratching. We recommend using moving blankets surrounded by plastic wrap.

Storage temperature can be between 5 °F (-15 °C) and 140 °F (+60 °C)

- Let equipment sit for at least 2 hours if range was outside of ambient temperature range.

Disposal

There are environmental regulations for disposal of lamps and batteries. Lamps contain fluorescent materials and other waste containing mercury. Contact your local health department, local garbage disposal or city authority to find out how to properly dispose of the equipment.

Packaging contains recyclable material.



Waste of electrical and electronic equipment must be disposed as unsorted municipal waste. It must be collected separately, and must be disposed as per local regulations. Contact ProSun International LLC or an authorized representative for information concerning the decommissioning of your equipment.

Control Functions



#	Function	Description	Additional Information
A	Start	Use this button to start the session.	
B	Stop	Use this button to stop or pause the session.	
C	Minus	Decrease time	Decrease cooling fan speed
D	Plus	Increase time	Increase body cooling fan speed
E	Face Lamp	Not Applicable for this bed	
F	Fan	Use this button to use the fan	

Operation



Note: Typically *Stand-alone mode* is for residential use and *Remote mode* is for commercial use
All units come standard in *remote-mode*

A Start

Stand-alone mode:

By depressing start once the “+ and –” buttons can be used to set the time. Pressing for a second time will start the unit.

B Stop

Stand-alone mode: (for residential units)

Pressing stop once will cause the unit to “pause”. The lights will go out but the ventilation will continue to run.

Pressing stop twice will initiate a mandatory after-cooling phase of 3 minutes. The unit cannot be started during these 3 minutes.

Remote mode: (only for commercial units)

Pressing stop once will cause the unit to “pause”. The lights will go out but the ventilation will continue to run.

The unit will not respond to pressing stop several times. The external timer automatically will switch the unit off. Switching off will initiate a mandatory cool down of 3 minutes. The unit cannot be started during these 3 minutes.

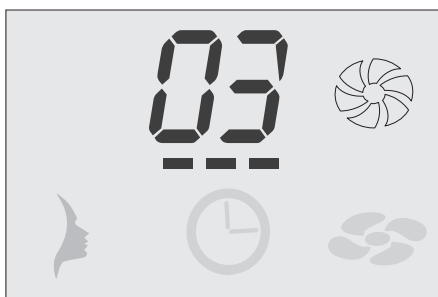
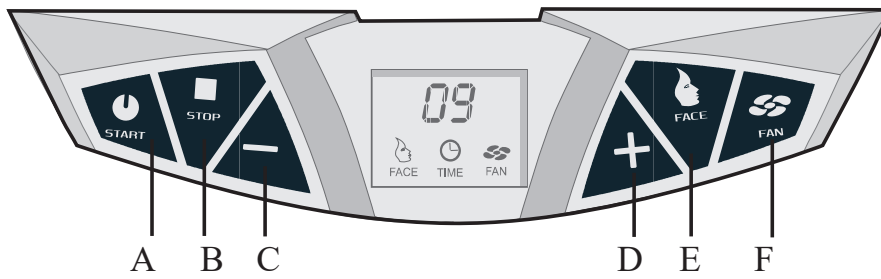

Illustration after-cooling



- ⊖ **Stand-alone mode:**
 - a. Reduce Session time
 - b. Reduce body cooler speed

- Coin mode:*
 - a. Reduce body cooler speed

- ⊕ **Stand-alone mode:**
 - a. Increase Session time
 - b. Increase body cooler speed

- Coin mode:*
 - a. Increase body cooler speed

- 👤 **Face**
Not Used in this bed

- 🌀 **Fan**
Switch the body cooler on and off

Error messages



Display messages:



Overrule error (Switch print and/or display print defective)

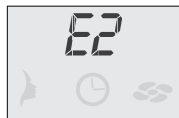

Unit is overheating



Communication error (No communication between switch print and display print)



Note: When you receive one of the above error messages on your LCD display, you should stop using the unit and unplug it. Please contact your dealer.

Care and Maintenance

The Care and Maintenance in this section provides information on how to properly care for your equipment after each use and during the lifespan of the unit. It will help provide you with basic troubleshooting and maintenance questions. If your bed fails to operate properly, please review the following steps before calling for service.

THE BED YOU PURCHASED CONTAINS VOLTAGES WHICH ARE POTENTIALLY HAZARDOUS. IN THE FOLLOWING PAGES YOU WILL RECEIVE A CLEAR DESCRIPTION OF WHAT CARE AND MAINTENANCE CAN BE DONE BY A NON-SKILLED PERSON THAT HAS READ AND UNDERSTOOD THE MANUAL AND WHICH REPAIRS AND MAINTENANCES SHOULD BE PERFORMED BY CERTIFIED TECHNICIANS.

FOR YOUR BED:

Safe and continuous operation of your bed depends partially on the care taken by users. Please observe the following precautions when bed is in use.

- Do not allow sharp object in the bed while in use. Avoid having the acrylic sheets coming in contact with sharp edges or objects.
- Do not allow liquid or any foreign objects to get inside the unit.
- Ensure the back side of the unit is at least 8 to 12 inches from the wall.
- The room in which the unit is located must be well ventilated.
- Make sure the unit never comes in contact with water while connected to power.
- Do not turn the Machine on and off frequently within the space of 3 minutes.



DANGER - High Voltage !

You can be killed or injured by an electric shock!

During maintenance and service work there is a risk that you can touch live parts and could receive a fatal shock. When performing basic care maintenance and before a certified technician performs maintenance work they should make sure:

- The device is disconnected from the power supply.
- The device is not in use.
- Do not reach behind the cover plates and do not open the unit while it is switched on.
- Refit and safety devices after work has been completed.

If service or maintenance work is going to be performed on the equipment then they must be deenergized. Meaning that all live cables must be switched off.

Switching off the device alone is not enough, certain points may still be energized. Therefore, switch off fuses before performing any work, if possible also remove these fuses before starting.

Accidental reactivation can result in serious accidents. Immediately after deenergizing the equipment, secure all switches or fuses used for deenergizing against being switched on again.

For more maintenance information please visit our website at:

www.prosun.com/customer-service

Basic Care Maintenance

Basic Care Maintenance and service of your equipment play a major role in maintaining the units performance and appearance over the period of its useful life. Compliance at the intervals specified for your unit are absolutely necessary to ensure the proper operation of the equipment. The table below is a preventative care table that can be done by any unskilled person, if any service outside of this table is needed please contact ProSun immediately and this would should only be done by a certified technician.

The equipment should be routinely serviced and maintained by a ProSun certified technician.



WARNING!

WARNING!

Injuries and damage due to improper maintenance!

Improper maintenance can cause the unit to become inoperable.

Always comply with the maintenance schedule supplied in this manual and follow cleaning/ disinfecting instructions.

Maintenance Schedule:

Frequency	After Each Session	Daily	Weekly	Every 1 to 3 Months
Cleaning all components in contact with user (MP3 cable, acrylics, goggles, etc)	X			
Unit base, control panel and handles	X			
Click Strips are firmly in place	X			
Clean & Sanitize Bed Exterior		X		
Remove & Clean inside of acrylic sheets				
Dust Lamps				X
Wipe & Vacuum fans & vents			X	
Clean all reflectors				X
Inspect Acrylics for cracks & wear		X		
Check hinges bolts for proper tightness		X		
Inspect vent hoses for optimum ventilation			X	

Lucasol™ 4-Step Cleaning Process

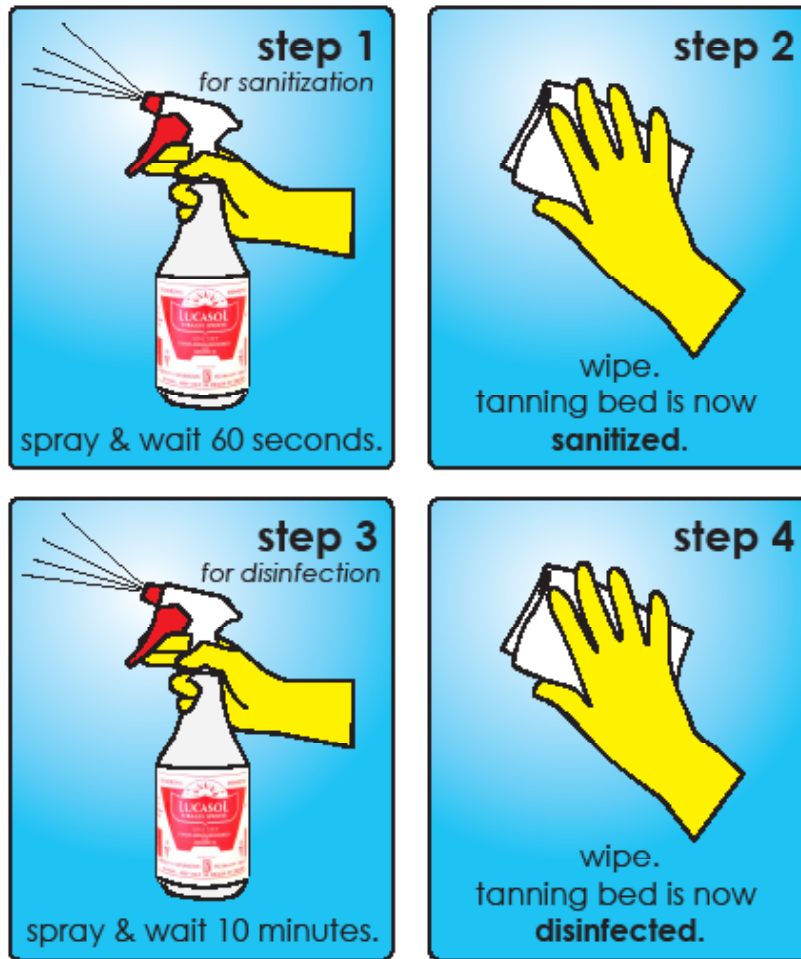

- STEP 1** After use, spray the tanning bed spray with Lucasol™ disinfectant and let disinfectant sit for 60 seconds to kill 99.99% of bacteria, fungus, and virus.
- STEP 2** Wipe tanning bed surface to remove Lucasol™ and any tanning lotion residue. The bed is now sanitized.
- STEP 3** Spray tanning bed again and let Lucasol sit for 10 minutes to achieve 100% disinfection, killing 100% of bacteria, fungus, and virus.
- STEP 4** Wipe remaining Lucasol™ from the surface of the bed. The bed is now disinfected.

Following this 4-Step process will minimize the risk of spreading infectious disease and offer the tanning bed user the best possible results.

*Not all tanning bed disinfectants kill 99.99% of bacteria, virus, and fungus in 60 seconds. If you are not using Lucasol™ read the label on your disinfectant bottle for proper directions.

NOTE:

For thorough cleaning and disinfection, the product you are using has to remain in contact with the surface that is being cleaned and disinfected for a specific amount of time, as mentioned on the instructions of the product. The specific amount of time will depend on the type of cleaner/disinfectant that you are using. Follow the directions on the product.

After the specified application time remove remaining cleaner/disinfectant from the surface of the equipment.

The service of this equipment may only be done by an authorized technician or trained and qualified staff.

The below basic maintenance can be done by an unskilled person.

Cleaning Plastic Surfaces:

For cleaning plastic surfaces we recommend using regular soap and warm water. Never use an aggressive cleaning agent that contains alcohol or essential oils. Using inappropriate cleaners may cause permanent damage not covered by warranty. Remove all jewelry and loose items before cleaning.

Cleaning Lamps:

Low pressure lamps can be cleaned with a damp cloth(without any additional cleaning agents). Dust lamps with a dry soft cloth - do not use cleaning fluid or alcohol.

Cleaning the machine

Always disconnect the main power from the unit before attempting to clean or repair it. Dust the lamps with a dry cloth - do not use cleaning fluid or alcohol. We recommend using Lucasol as the cleaning product. The acrylics should be taken out at least once every week of operation and cleaned thoroughly with a non-alcoholic disinfectant glass or surface cleaner. If alcohol is used, the acrylic may fade, crack, or break altogether. Use a vacuum cleaner with a dust nozzle to clean around the ballast racks and throughout the interior portions of the base, top deck, and bench.

Maintenance by skilled persons:

ProSun recommends having an annual inspection by a certified technician to review connections, check for loose wiring, check the power cords and review all other high voltage components. At this time the certified technician can dust all electronic components.

Troubleshooting guide

PROBLEM	PROBABLE CAUSE	POSSIBLE SOLUTION
Unit is Activated but nothing happens	<ul style="list-style-type: none"> No Power to the unit. Timer clears after priming Remote timers do not work. Incorrect voltage 	<ul style="list-style-type: none"> Check to see if unit is connected to the power source. Restart timer and try again. Check that it is plugged in and contact ProSun customer service for replacement parts. Get voltage reading from certified technician.
Unit appears to be too hot	<ul style="list-style-type: none"> Fans are obstructed Room is too small 	Ensure all fans are clear of obstructions and dust. Check that your room is the correct size as described earlier in the manual.
Room temperature abnormally warm	Unit too close to the wall	Pull unit away from wall at least 10 - 12 inches.
Individual lamps do not light	<ul style="list-style-type: none"> Lamps not properly in sockets. Lamps or starters are defective. Ballast are defective. Loose wires Lamp lifecycle has ended. 	<ul style="list-style-type: none"> Turn lamp in socket units lamp illuminates. Replace lamp or starts. Replace ballast- Must be done by certified technician. Reconnect wire - Must be done by certified technician.
Unit goes in to ERROR Mode	See setup manual	Contact ProSun customer service
Canopy does not stay open.	Shocks may be damaged	Check shocks are installed per assembly instructions in this manual. Contact ProSun customer service for parts.
Cracked acrylic	Damage to equipment by user or cleaning	Contact ProSun for replacement. Non-skilled person can replace acrylic.



Any troubleshooting outside of the above mentioned guide should be done by a certified technician. Contact ProSun to schedule service with a certified technician.

Replacement of Components



WARNING!

WARNING: Before doing any repair or replacement work on this machine, ALWAYS disconnect the power at the main circuit breaker(or, if the main power cable has a wall plug, pull it out).

IMPORTANT: Only use manufacturer-authorized replacement components. Failure to do so may void warranty.

Longevity of the acrylic sheets

The acrylic sheets used in this machine should be changed between 1200 and 1500 hours of operation.

The acrylics for the unit are produced of an acrylic glass developed specifically for Red Light sessions. The use of other acrylic material can cause serious injury.

ProSun® recommends the use of Lucasol One Step when cleaning acrylic sheets. Acrylics in equipment are extremely porous and should not be cleaned/disinfected with non-approved products.

Longevity of the lamps

Lamps will last anywhere from 1000-1200 hours.

Disposal of Lamps

Lamps contain fluorescent materials and other waste that contain mercury. Certain areas in the US and Canada have specific regulations on disposal of these wastes, you can contact your health department, local garbage disposal company or city authority to find out where and how to properly dispose of them. You should retain proof of proper lamp disposal.

WARNING!

Risk of mercury toxicity

Risk of mercury toxicity after lamp breakage. Ventilate the room or area at least 15 minutes before disposing of the fragments.

Technical Modifications



WARNING!

This unit has been manufactured in accordance with current safety regulations. The illustrations and specifications are subject to changes in order to improve the device.

Unauthorized modifications and changes to the device and its controls are prohibited.

ONLY USE ORIGINAL PARTS! Use of any other parts voids the warranty and ProSun will not be liable in any cases of damage or injury due to the use of these parts.

Replacing the Acrylics

- 1 Bend back the plastic grey strip

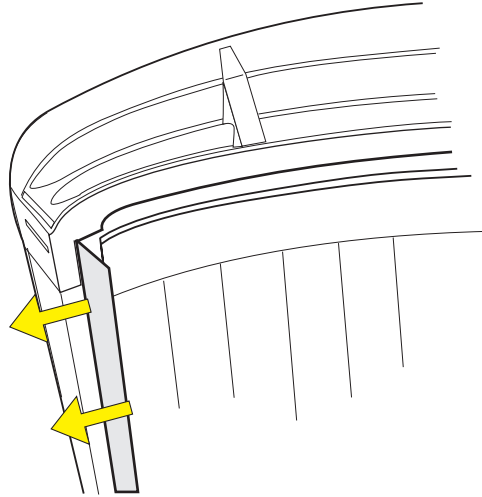

2

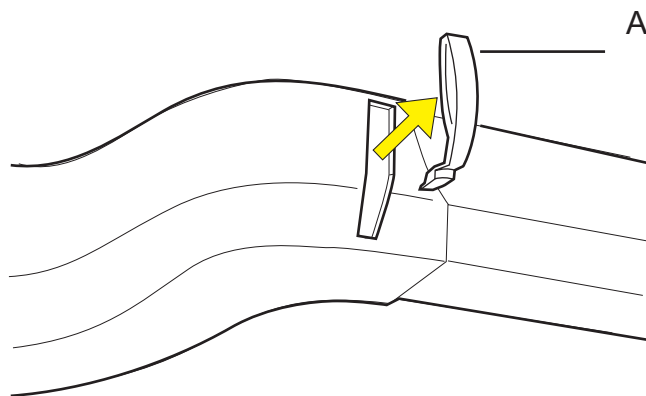

Acrylic tool

At the end of the bench or canopy you will find an acrylic tool. Remove it from the unit and use this to slide under the acrylic and lift it up gently.

3

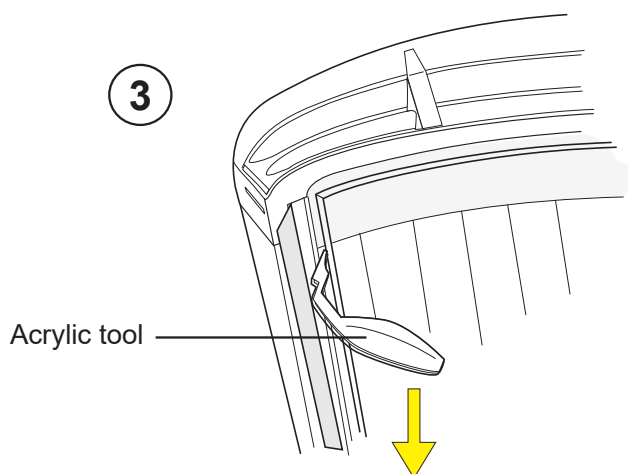

Acrylic tool

Pull back the acrylic sheet by hand first, then use the acrylic tool to remove the rest of the sheet.

You may want to wear gloves due to sharp edges of acrylic.

Replacing the Lamps

Once you have removed the acrylic you will want to unscrew and remove the metal lamp covers/ strips. Then with gloves on to protect the lamps from oils, twist the lamp and remove. When replacing the lamp twist the lamp back into position. Listen for 2 clicks to ensure the lamp is securely fastened.

A Unscrew and
remove metal strip

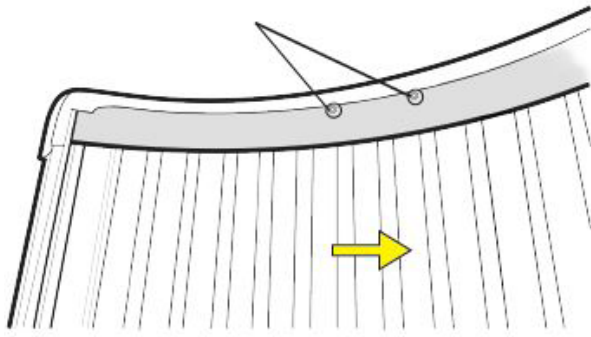

B

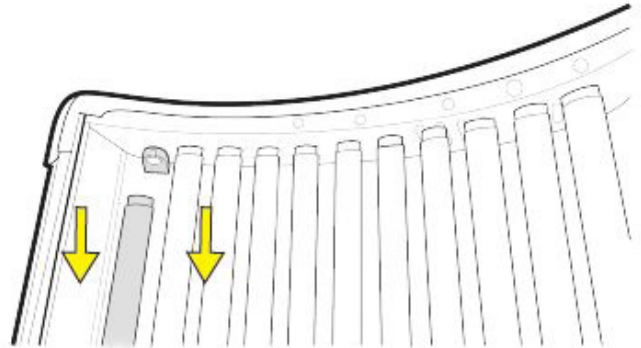

Assembly Introduction

Required for assembly (not included):

- 1 wrench to tighten bolts

*Make sure to write the Serial Number (located on the back of the canopy) down on the previous page and store the manual somewhere you can easily access. The Serial Number is **MANDATORY** to order parts for your unit, as well as, any customer service calls.

The boxes should be shipped in this manner.

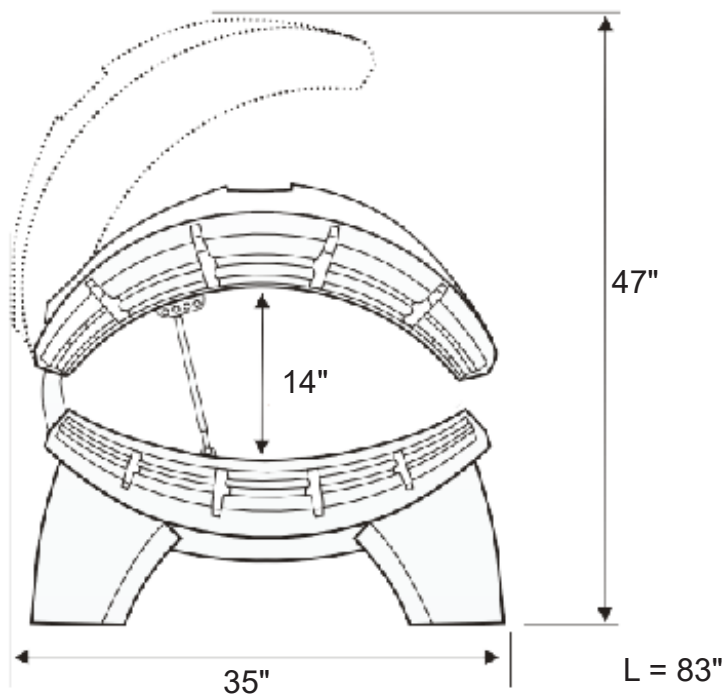
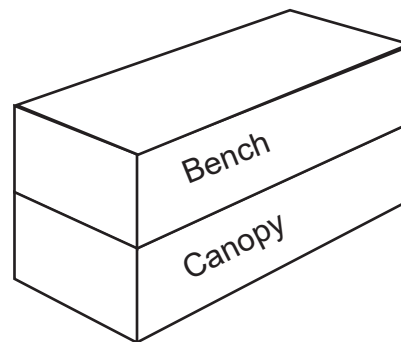

Side view

Included Parts

Make sure all parts are included before you begin.



2 Combi Arms
FAMS6012171

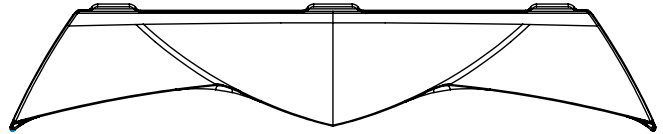

1 Plastic Front Skirt (optional)
bronze - CVPL 6012336
red - CVPL 6513606
white - CVPL 6525156



6 Combi Arm Screws
FASN1508828



2 Security Plates
FAMS6012236



1 Gas Shock



4 Security Plate Screws
FASN1513151



4 Gas Shock Pivots
GASP9008435

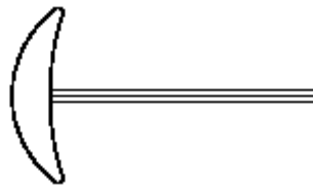

1 Alan Wrench
ACCE1009552



4 Security Clips
GASP90008436



2 Deco Shield Screws (optional)
black
FASN5010879



2 Deco Shield Washers
FASN6001362



2 Deco Shield Nuts
FASN3001132

Assembly

Carefully remove the bench from box and keep it face down.

*Optional Front Skirt (if you do not have a plastic front skirt go to step 3)

Retrieve

1 *Plastic front skirt* (located in canopy box)

Remove the screw from the leg.

1

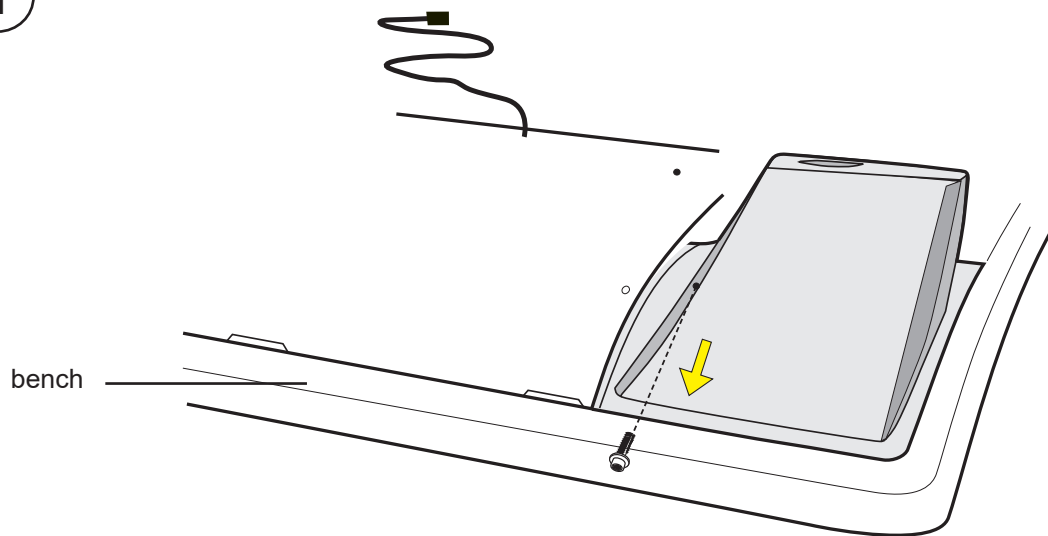

2

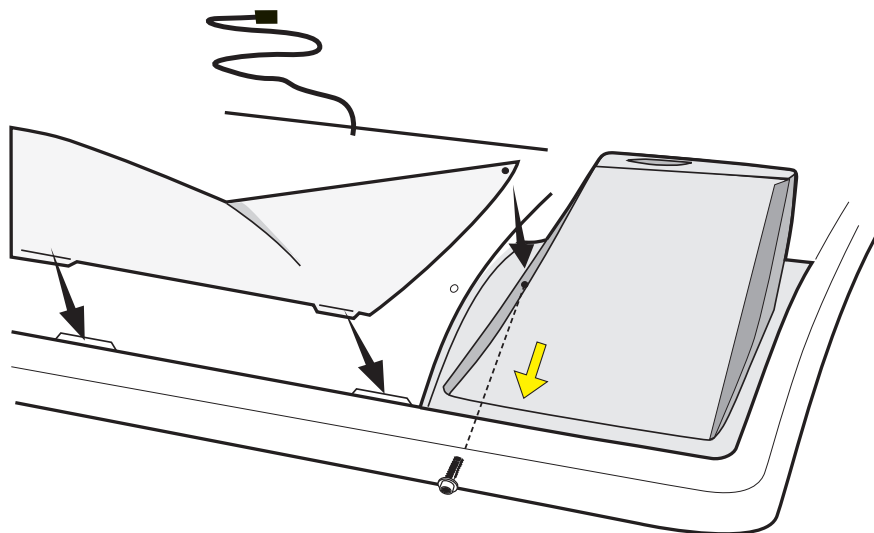

Insert *plastic front skirt* and screw in place. Repeat these steps on other side.

Flip bench over.

Retrieve

2 Combi Arms

6 Combi Arm Screws

Remove the end cap filler.

3

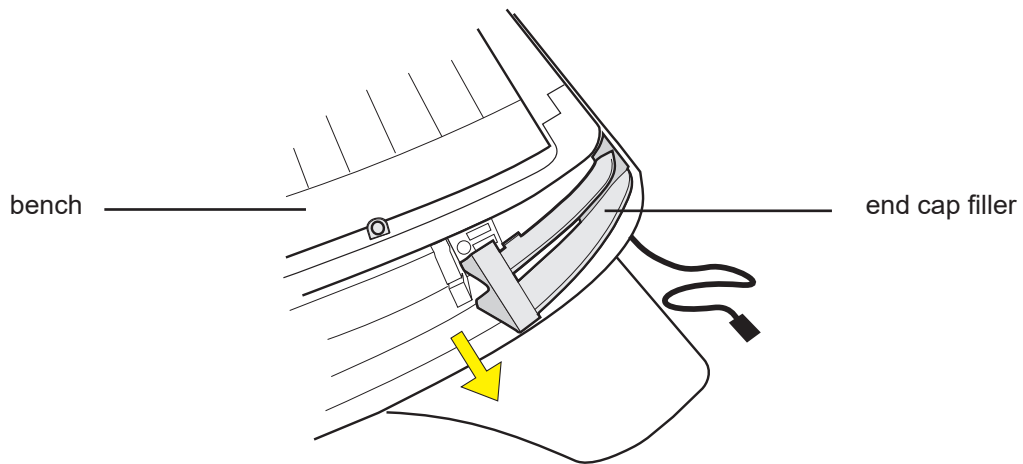

4

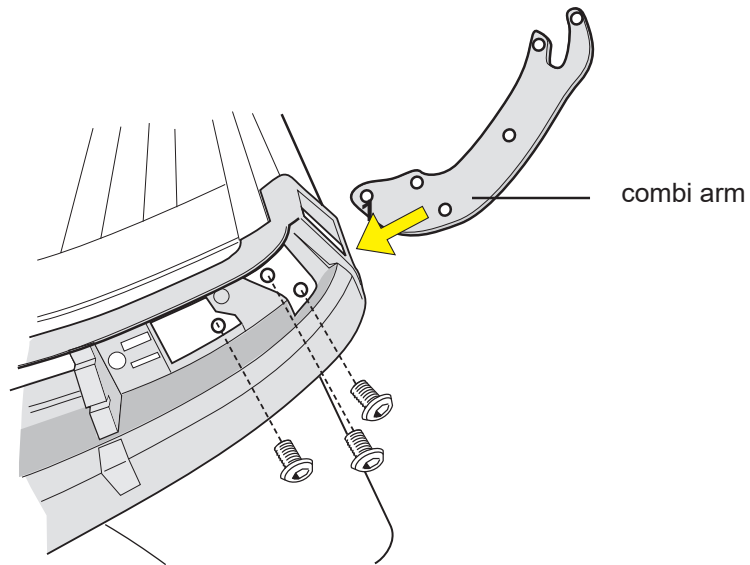

Insert combi arm into bench and secure with screws. Repeat these steps on other side.

Remove the canopy from the box.
Remove the end cap filler as done previously with the bench.

While holding the canopy on each end attach it to the bench by sliding it onto the combi arms

5

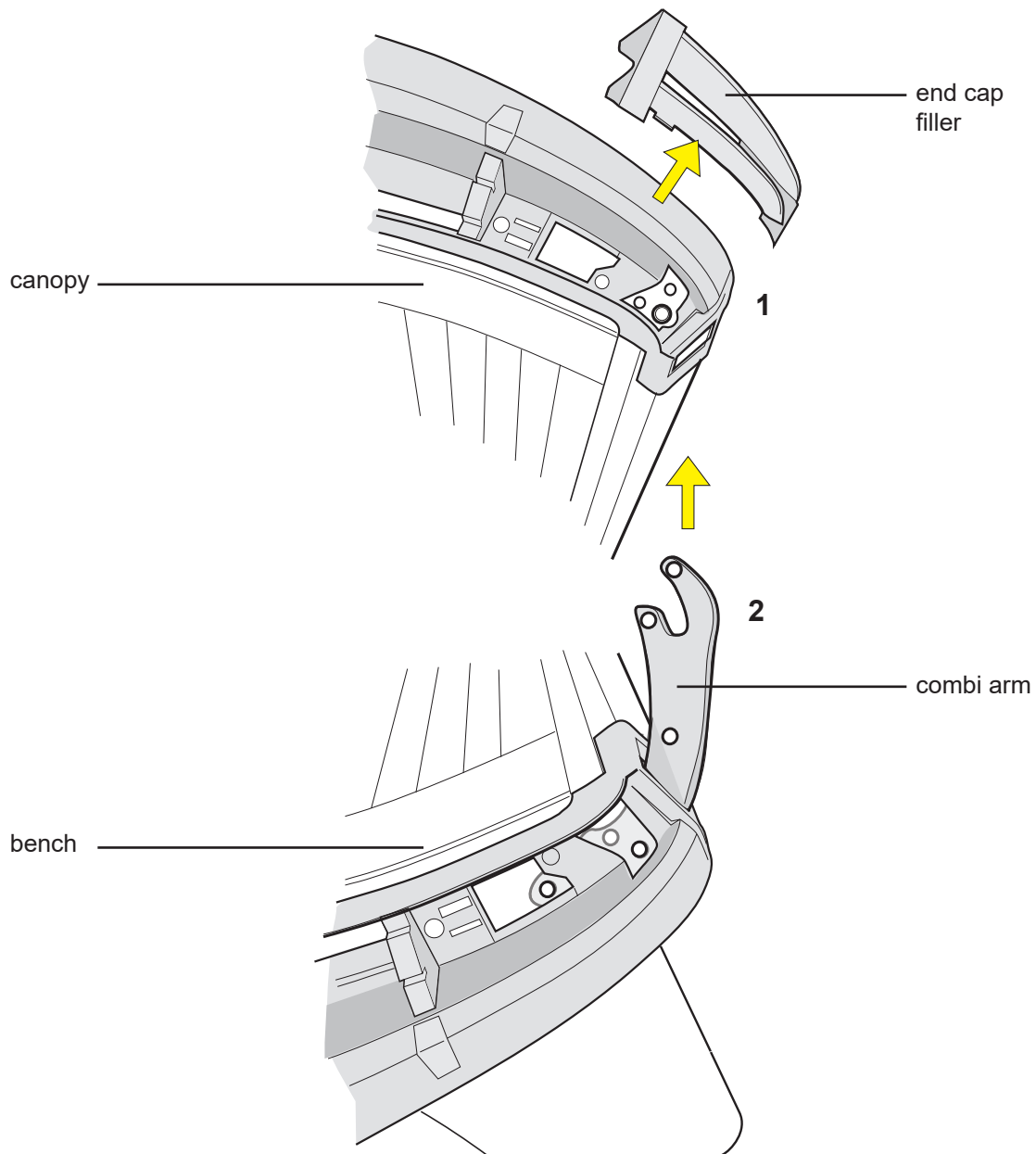

Retrieve

2 *security plates*

4 *security plate screws*

Once the canopy is attached to the bench, secure the *security plate* into place with *security plate screws*.

Repeat these steps on other side.

6

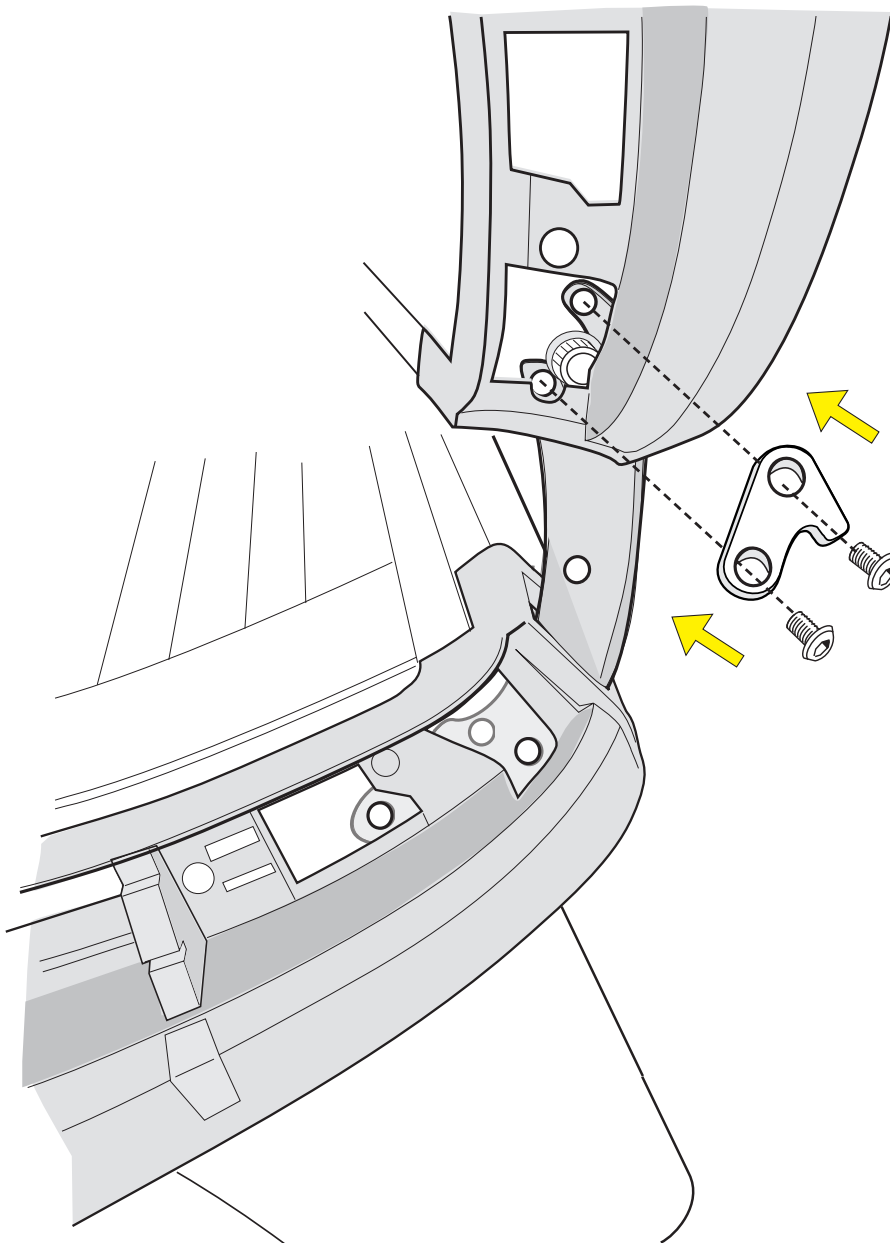

Retrieve

2 Gas shocks

4 Gas shock pivots

4 security clips

While the canopy is in an open position, insert *gas shock* into the bench and into third hole on the canopy. Then insert *gas shock pivots* and secure with a *security clip*.

7

If the canopy rises spontaneously move gas shock to hole 2

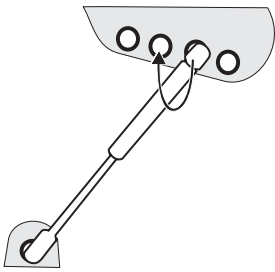

If the canopy lowers spontaneously move gas shock to hole 4

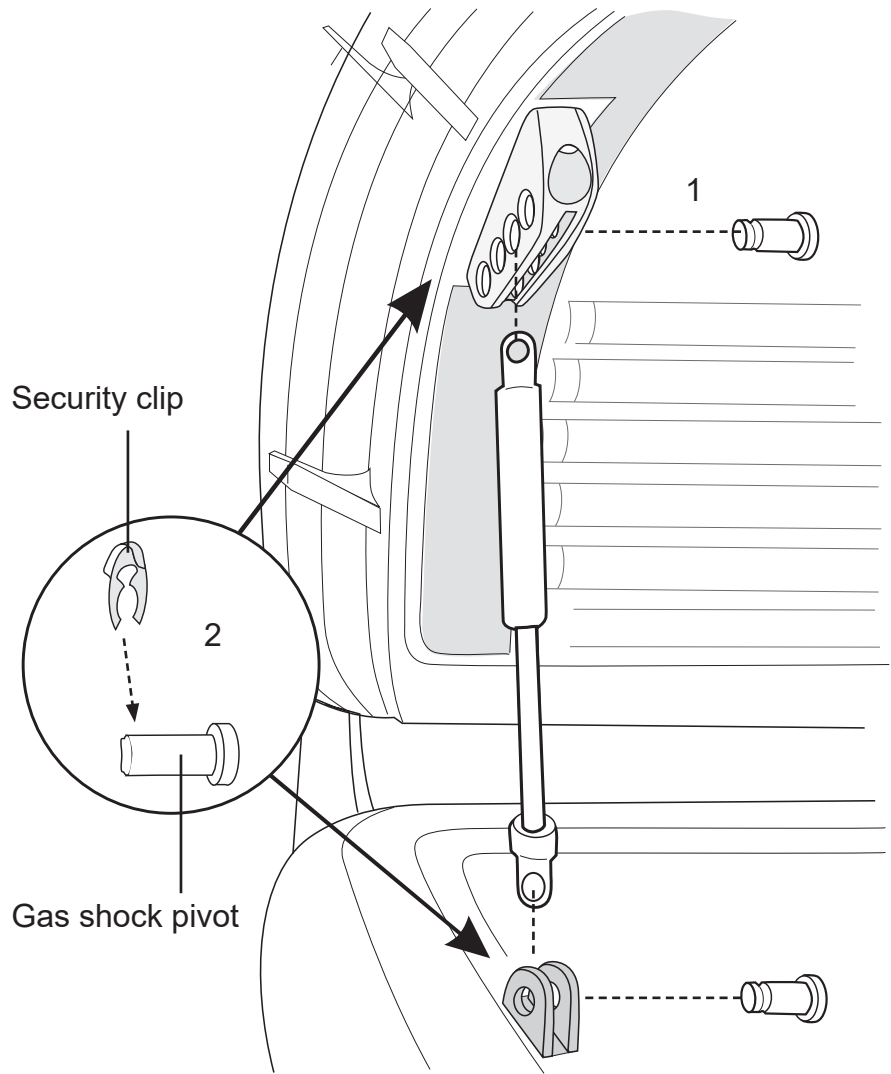
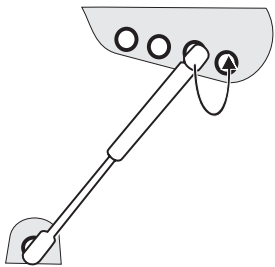

The four end cap fillers that were removed need to be inserted back into the bench and canopy.

8

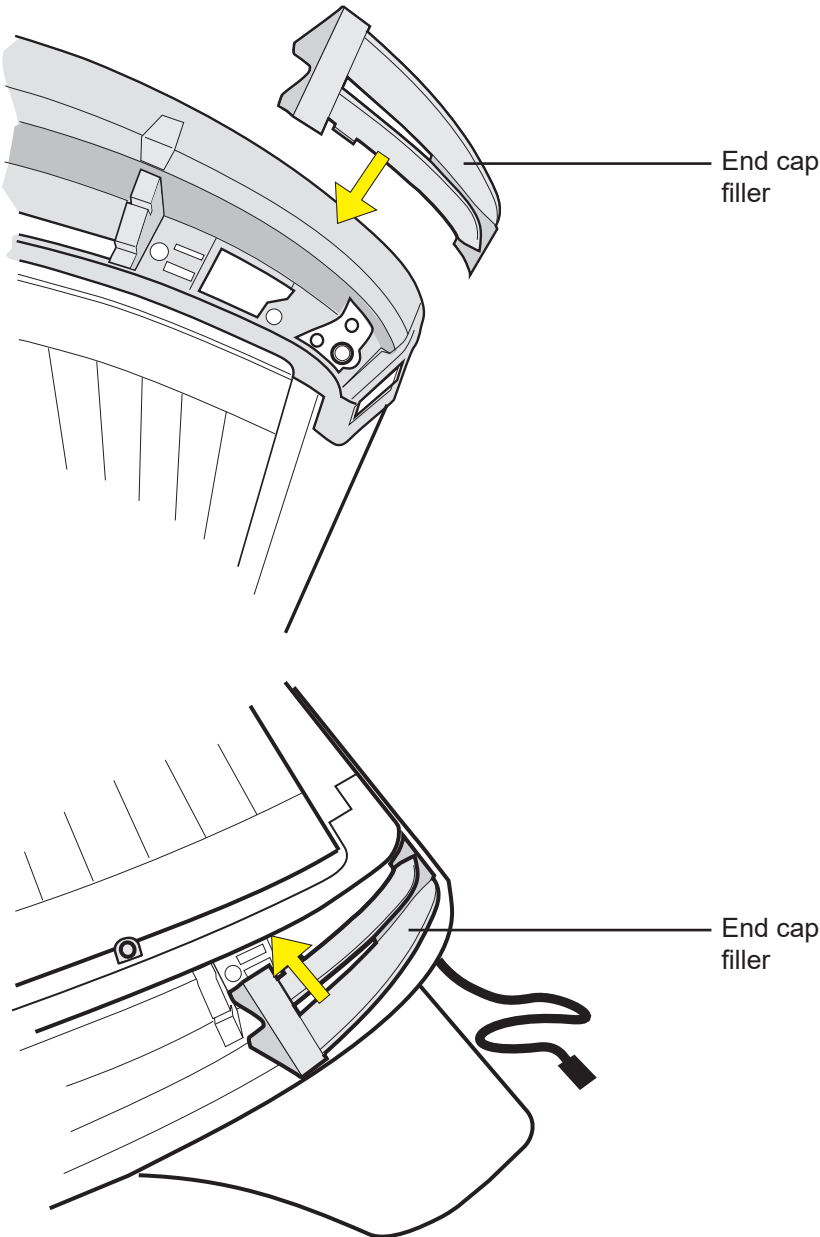

*Optional Deco Shield

Retrieve

- 1 Deco shield
- 2 deco shield screws
- 2 deco shield washers
- 2 deco shield nuts

Insert the *deco shield* in between the canopy and bench.

7

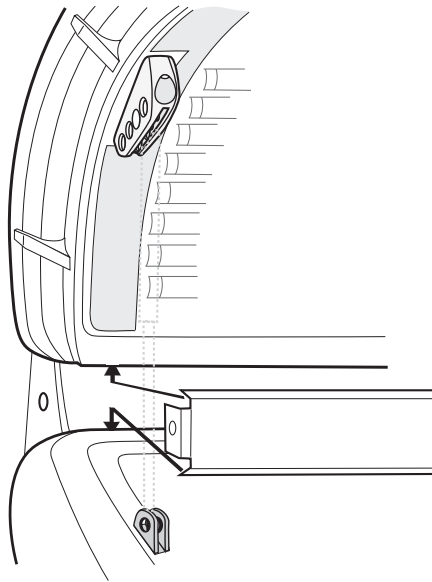

8

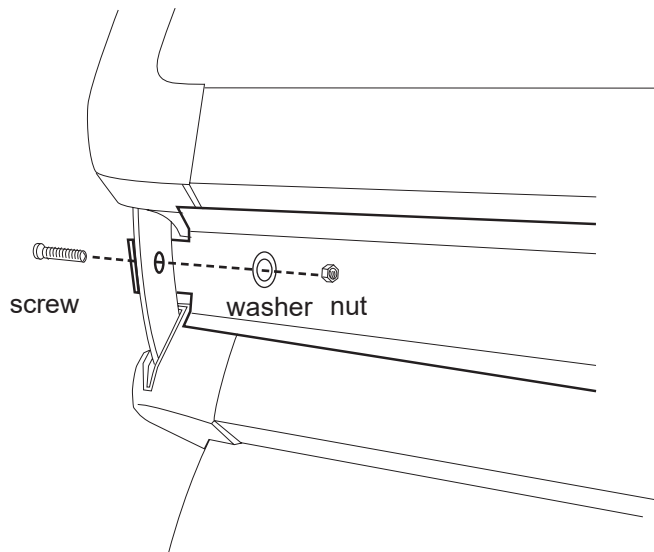

Secure by attaching the *deco shield* to combi arm.

On the back of the canopy you will see three chords:

Plug "A" into your wall outlet (or into optional buck booster)

Plug "B" in the bench

Plug "C" is not Applicable for this unit.

9

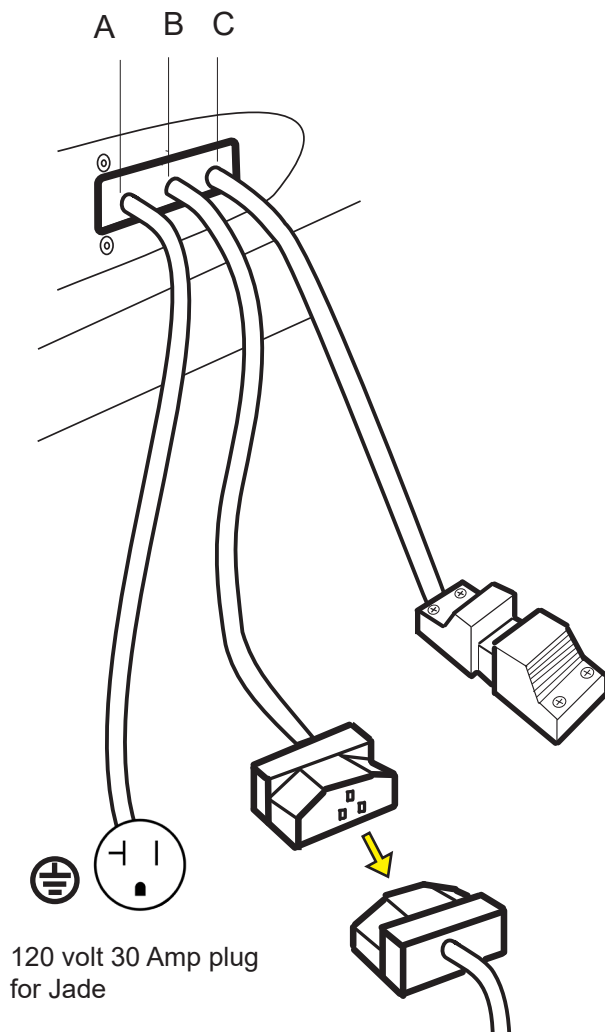

Warranty

ProSun Red Light Warranty LIMITED WARRANTY Revised January 2019

Warranty Period:

Provided it is still owned and operated by the original owner, PROSUN warrants all equipment manufactured or imported by it to be free from defects in material under normal use and service. Warranty Periods as specified below are from the date of delivery to the location. The warranty is non-transferable and is only valid for the original purchaser of the equipment.

What is covered:

During the Limited Warranty period as specified below, PROSUN will be repair or replace any defective system or components found to be defective, at PROSUN's sole discretion. Prior to making any repairs, the owner must provide PROSUN with information requested and perform basic troubleshooting. PROSUN will review the problem and provide disposition of parts and guidance to the authorized technicians performing the adjustments or repairs. Any repairs attempted or damage done as a result of such attempts, prior to reporting the problem for disposition and guidance by PROSUN customer service, shall void the limited warranty.

The cost to the Purchaser is based on the proration of the warranty on the defective system or components and labor. The limited warranty is as follows:

- 10 year warranty on steel frame
- 12 Months on Electronic Components.
- 90 days on Labor. (Note: additional labor warranty can be purchased at the time of purchase and renewed based on PROSUN's discretion and availability.

General Warranty Terms and Limitations:

- The Warranty Period is based on the date of delivery and contingent on proof of annual maintenance inspection/service. (Every 12 months or 1500 hours of operation.)
- The Limited Warranty will be null and void if equipment has been damaged and not reported and repaired or maintenance/service has not been performed as defined in the User Manual.
- Equipment must be owned by the original owner, in original installed location. It may not have been physically moved from its original installed location unless otherwise authorized by PROSUN and removal and re-installation performed by PROSUN certified technicians. Failure to do so will void the warranty.
- Outside of the normal maintenance recommended in the User Manual, any work performed on the equipment by a non-authorized technician without the express consent of PROSUN will void the warranty.
- All warrantied parts will be sent out with Ground shipping costs, expedited shipping will have an additional charge to the customer.
- Replacement parts purchased after the original warranty period are extended a 90-day warranty only if those parts have been purchased from PROSUN and installed per PROSUN's instructions and approval. Note: Payment in full is required prior to shipping replacement parts outside the warranty period or not included in the warranty. Any product being returned to PROSUN for repair, replacement or return must be adequately packaged to prevent freight damage and must be shipped via traceable methods unless otherwise authorized in writing by PROSUN.

What is not covered:

- Labor to replace warrantied parts or make repairs outside of the labor warranty period, or to perform annual maintenance.
- Any parts affected by discoloration or use of non-approved cleaners
- Damage caused by use for anything but its intended use, mishandling, abuse, negligence, external trauma due to overloading or not maintaining the equipment properly.
- Cosmetic damage, whether intended or due to wear and use.
- Damage due to improper electrical installation or connection including overpower, under power, and incorrect service connection - including any failure to the external voltage transformer (i.e. Buckboosters)
- Cracked or broken cover plates, end caps and sidebars
- Any failure of the external timing system (example: T-Max, FST timers and timer system components).
- Any damage caused by the failure of any supporting hardware not supplied by PROSUN.
- Acrylic sheets, starters (igniters), lamps, blue and clear filter glass.
- Tanning units, parts or components damaged in transit where PROSUN'S damaged goods policy is not followed by purchaser or purchaser's designee.

THIS WARRANTY DOES NOT APPLY TO ANY FAILURE OF PRODUCT DUE TO ALTERATIONS, MODIFICATIONS, MISUSE, ABUSE, NEGLIGENCE, ACT OF GOD, ACCIDENT, IMPROPER MAINTENANCE (INCLUDING LACK OF ANNUAL MAINTENANCE) OR INSTALLATION, USE OF PARTS NOT SUPPLIED BY PROSUN, FAILURE TO OPERATE AND USE THE PRODUCT IN ACCORDANCE WITH THE INSTRUCTIONS PROVIDED IN THE OWNER'S MANUAL SUPPLIED WITH THE PRODUCT OR FAILURE TO OTHERWISE MEET MANUFACTURER'S SPECIFICATIONS, OR IF THE SERIAL NUMBER HAS BEEN REMOVED, ALTERED OR DEFACED. ANY DAMAGES CAUSED BY THE USE OF NON-DISTILLED WATER.

Procedure for Requesting Warranty Work and Parts:

In the event of an issue that is covered under this limited warranty agreement, the customer must first contact PROSUN. PROSUN Customer Service will initiate a service ticket and issue you a Warranty/Incident claim number. The customer must work with ProSun by phone, email, or FAX to provide all necessary information on the issue with the equipment and perform basic troubleshooting tasks.

1. If your equipment has a manufacturer's defect within the first 90 days, the necessary parts will be sent to you via expedited shipping options. After being given a claim number by customer service, you will be sent and must sign our warranty documentation and return it to PROSUN prior to the parts being sent out.
2. A return shipping label will be provided. You will need to return the original or any unused parts to PROSUN unless otherwise advised in writing. If the original defective parts are not returned within 30 days, you will be responsible for the purchase charges for the parts. If unpaid, your account will be placed on hold until the issue has been resolved.
3. Any warranty parts needed outside of 90 day warranty period will require payment up front. A return label will be provided with your warranty parts and a full credit will be provided to your payment method within 10 business days of receiving the original or returned unused parts. If parts are not returned within 90 days or have been damaged, a credit will not be issued or may be subject to a restocking fee.
4. Depending on the labor warranty as stated in this agreement, PROSUN will help the customer by phone to replace the component or will schedule a technician to perform the service work.

Right to Modify:

PROSUN reserves the right to make changes or improvements to its products without incurring any obligations to similarly alter products which have been previously purchased.

Exclusivity of Warranty:

This warranty is the only warranty made by PROSUN and may only be modified or amended by a written instrument signed by a duly authorized officer of PROSUN. PROSUN's sole and exclusive liability and Purchaser's sole and exclusive remedy under this warranty shall be, at PROSUN's discretion, to repair or replace, to the extent available on a prorated basis, any such defective Products. These remedies are available only if PROSUN's examination of such Products discloses to PROSUN's satisfaction that such defects actually exist and were not caused by Purchaser's misuse, abuse, neglect, improper installation, maintenance or testing, alterations or modifications, failure to meet manufacturer's specifications or any other cause beyond the range of normal usage, or by accident, fire or other hazard. Repair or replacement of a part does not extend the warranty period or extend the prorated value of a part or product beyond the initial limited warranty periods as specified and set forth above.

THE WARRANTY SET FORTH ABOVE IS IN LIEU OF ALL OTHER WARRANTIES, EXPRESS OR IMPLIED, INCLUDING BUT NOT LIMITED TO ANY IMPLIED WARRANTY OF MERCHANTABILITY OR FITNESS FOR A PARTICULAR PURPOSE. IN NO EVENT SHALL

PROSUN BE LIABLE FOR ANY INCIDENTAL OR CONSEQUENTIAL DAMAGES WITH RESPECT TO THE PRODUCTS DELIVERED HEREUNDER OR SUBSEQUENT USE THEREOF.

Limitation of Liability:

PROSUN shall not be liable for any loss, damages, or penalty resulting from failure to perform any of its obligations under this Agreement due to major force or any cause beyond its reasonable control.

PROSUN'S LIABILITY UNDER OR FOR BREACH OF THIS AGREEMENT SHALL NOT EXCEED THE REFUND OF THE PURCHASE PRICE LESS REASONABLE RENTAL FOR PAST USE. IN NO EVENT SHALL PROSUN BE LIABLE FOR COSTS OF PROCUREMENT OF SUBSTITUTE GOODS BY THE PURCHASER OR FOR UNAUTHORIZED REPAIRS UNDERTAKEN BY THE PURCHASER WITHOUT PROSUN'S PREVIOUS WRITTEN APPROVAL. IN NO EVENT SHALL PROSUN BE LIABLE FOR ANY SPECIAL, CONSEQUENTIAL, OR INCIDENTAL DAMAGES, HOWEVER CAUSED, WHETHER FOR BREACH OF WARRANTY, NEGLIGENCE, OR OTHERWISE. PROSUN DISCLAIMS ANY OBLIGATION OR LIABILITY FOR LOSS OF USE OF THE PRODUCT WARRANTED, LOSS OF TIME, INCONVENIENCE, RENTAL OR SUBSTITUTE PRODUCTS, LOSS OF BUSINESS, LOSS OF INCOME, COMMERCIAL LOSS OR ANY OTHER DIRECT, CONSEQUENTIAL, SPECIAL OR INCIDENTAL DAMAGES.

Governing Law: Notwithstanding principles of conflicts of law of any jurisdiction to the contrary, all terms and provisions of this Agreement are to be construed and governed by the laws of the state of Florida without regard to the laws of any other jurisdiction. The Purchaser waives any and all privileges and rights which they may have under Chapter 47, Florida Statutes (1993), relating to venue as it now exists or may hereafter be amended, and under any other statute, or administrative provision thereof in any legal action on this Agreement; and further, the Purchaser agrees that any legal action brought on this Agreement or in connection therewith, shall be brought in the appropriate court in Pinellas County, Florida.

Attorney's Fees: Should a dispute arise with regard to this warranty or any other aspect of this sale the prevailing party shall be entitled to reasonable attorney's fees and costs through appeal under Florida Law.



ProSun
INTERNATIONAL LLC
innovative wellness solutions

ProSun International, LLC
2442 23rd Street North
St Petersburg, FL 33713
www.ProSun.com
800-874-2776