

Salon Ambience

LUXURY SINGLE WU/015 - WU/016
LUXURY DOUBLE WU/120 - WU/121
WU/122 - WU/123
LUXURY TRIPLE WU/130 - WU/131
WU/132 - WU/133
WU/134 - WU/135
WU/136 - WU/137

Salon Ambience

LUXURY SINGLE WU/015 - WU/016
LUXURY DOUBLE WU/120 - WU/121
WU/122 - WU/123
LUXURY TRIPLE WU/130 - WU/131
WU/132 - WU/133
WU/134 - WU/135
WU/136 - WU/137

Contiene informazioni riguardanti
l'installazione e la manutenzione del
lavaggio Luxury singolo, doppio e
triplo di Salon Ambience.

INDICE

CAPITOLO 1: INTRODUZIONE

Introduzione.....	5
Informazioni sul lavaggio.....	6

CAPITOLO 2: INSTALLAZIONE

Installa il tuo lavaggio: Acqua Elettricità.....	7
--------------------------------------------------	---

CAPITOLO 3: ISTRUZIONI

Utilizzare il tuo lavaggio: Luxury single WU/015.....	10
Luxury double WU/120 - WU/122 - WU/123.....	10
Luxury triple WU/130 - WU/132 - WU/133 - WU/134 - WU/135 - WU/136 - WU/137	10
Utilizzare il tuo lavaggio: Luxury single WU/016 - Luxury double WU/121.....	11
Luxury triple WU/131 - WU/132 - WU/133 - WU/134 - WU/135 - WU/136 - WU/137	11

APPENDICE

Manutenzione generale.....	12
Pulizia.....	12
Caratteristiche tecniche.....	12
Dichiarazione di conformità.....	63

INTRODUZIONE

LUXURY SINGLE WU/015 - WU/016
LUXURY DOUBLE WU/120 - WU/121
WU/122 - WU/123
LUXURY TRIPLE WU/130 - WU/131
WU/132 - WU/133
WU/134 - WU/135
WU/136 - WU/137

Grazie per aver scelto questo lavaggio Salon Ambience - una scelta eccellente!

Lo straordinario lavaggio Luxury di Salon Ambience offre un sorprendente comfort e stile; raffinato e curato nei dettagli, è dotato di alzagambe elettrico e di massaggio NEW SHIATSU® di nuova generazione. La sua forma morbida aggiunge stile al salone, mantenendo allo stesso tempo il comfort straordinario di tutti i prodotti Salon Ambience.

Il massaggio NEW SHIATSU® del nuovo lavaggio Luxury di Salon Ambience è studiato appositamente per decontrarre i muscoli e sciogliere le tensioni della zona lombare, sacrale e dorsale, lasciando una sensazione di leggerezza, tonicità e relax nel cliente. Il massaggio lavora su quattro punti di pressione differenti bilanciati ed ha una superficie di lavoro allargata rispetto alle versioni fino ad ora utilizzate.

INFORMAZIONI SUL LAVAGGIO



Disponibile in una vasta gamma di Sky Colours

INSTALLAZIONE MISURE

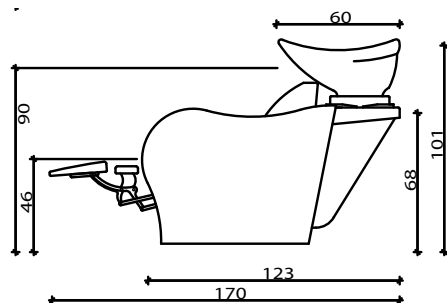

LUXURY SINGLE WU/015 - WU/016

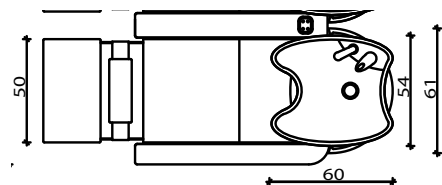

LUXURY DOUBLE WU/120 - WU/121 WU/122 - WU/123

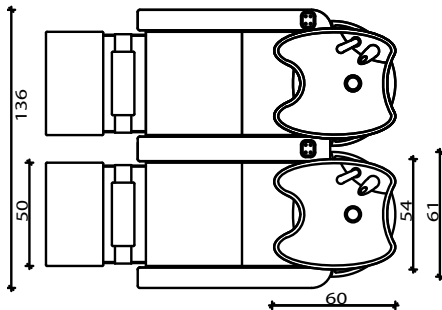

LUXURY TRIPLE WU/130 - WU/131 WU/132 - WU/133 WU/134 - WU/135 WU/136 - WU/137

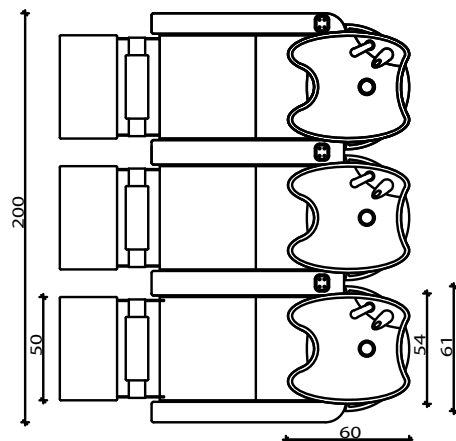

INSTALLAZIONE

INSTALLA IL TUO LAVAGGIO: ACQUA - ELETTRICITÀ

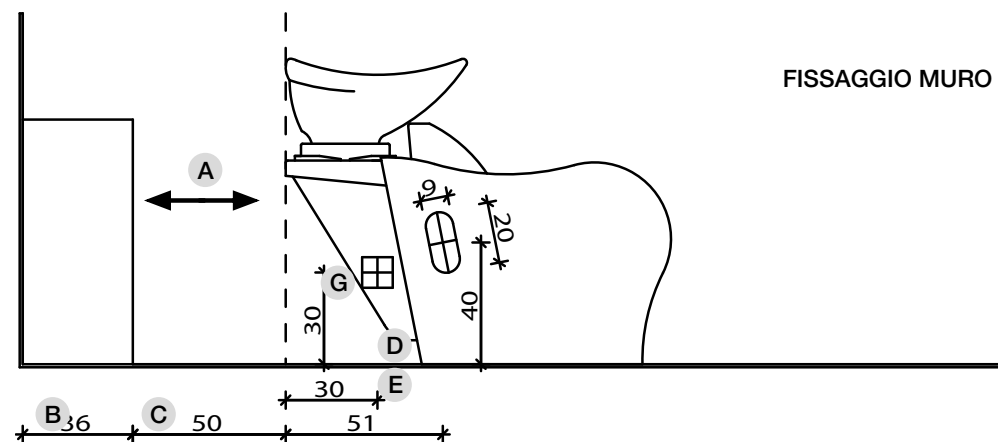
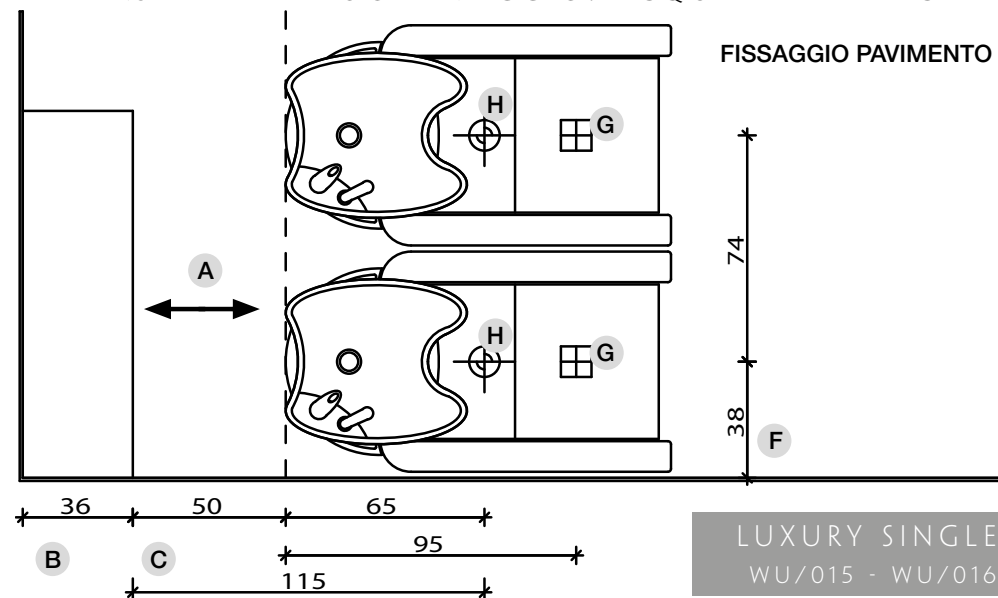

- A** Spazio di lavoro
- B** 36 cm per il mobile 'Service Centre'
48 cm per il mobile 'Wall System'
- C** Misura variabile - Non meno di 50 cm
- D** Entrata tubo acqua calda e fredda
- E** Uscita tubo acqua
- F** Misura dal muro
- G** Punto elettrico - 220V
- H** Carico acqua 3/8" - Scarico Ø40

INSTALLAZIONE

INSTALLA IL TUO LAVAGGIO: ACQUA - ELETTRICITÀ

FISSAGGIO PAVIMENTO

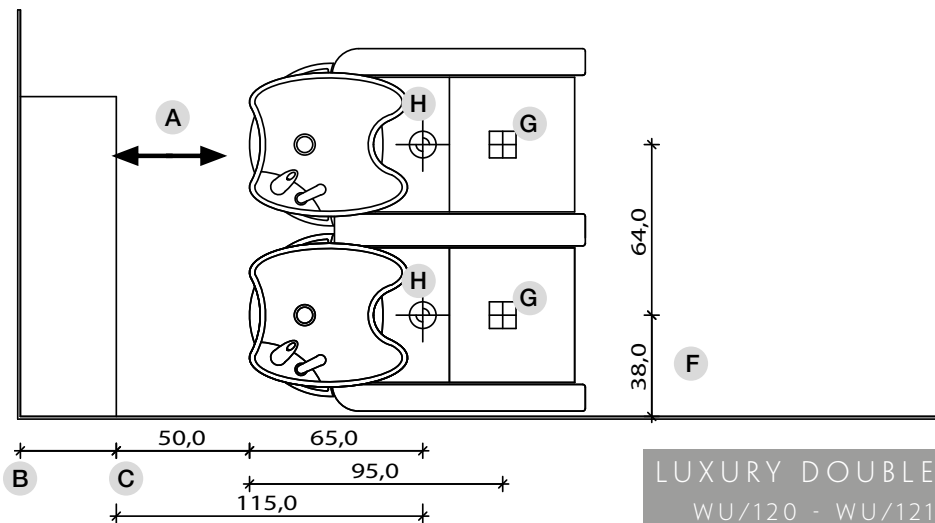

LUXURY DOUBLE
WU/120 - WU/121
WU/122 - WU/123

FISSAGGIO MURO

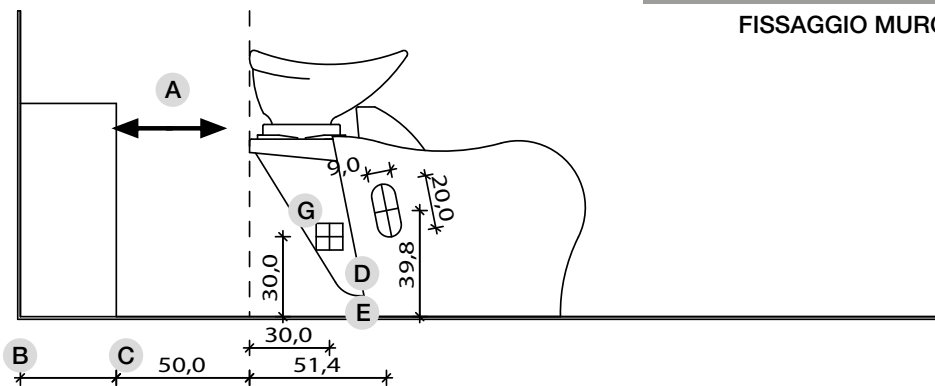

- A** Spazio di lavoro
- B** 36 cm per il mobile 'Service Centre'
48 cm per il mobile 'Wall System'
- C** Misura variabile - Non meno di 50 cm

- D** Entrata tubo acqua calda e fredda
- E** Uscita tubo acqua
- F** Misura dal muro
- G** Punto elettrico - 220V
- H** Carico acqua 3/8" - Scarico Ø40

INSTALLAZIONE

INSTALLA IL TUO LAVAGGIO: ACQUA - ELETTRICITÀ

FISSAGGIO PAVIMENTO

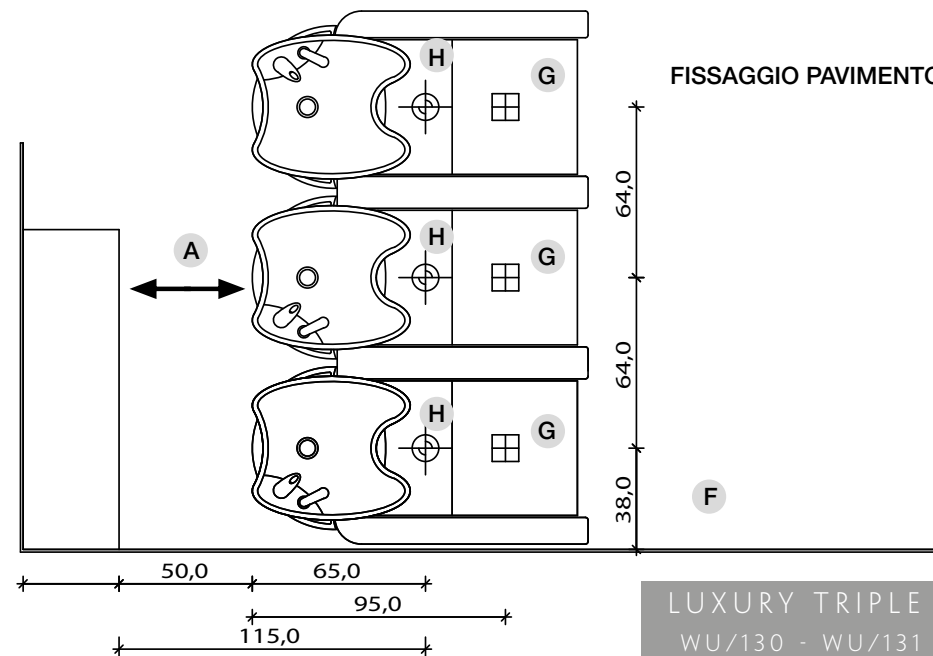

LUXURY TRIPLE
WU/130 - WU/131
WU/132 - WU/133
WU/134 - WU/135
WU/136 - WU/137

FISSAGGIO MURO

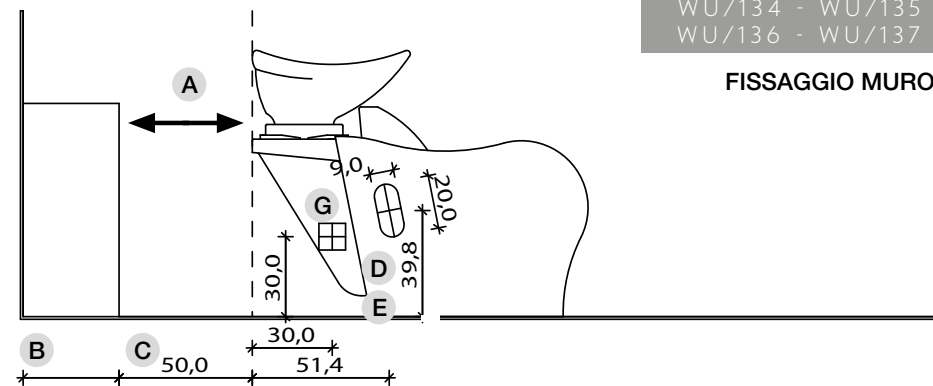

- A** Spazio di lavoro
- B** 36 cm per il mobile 'Service Centre'
48 cm per il mobile 'Wall System'
- C** Misura variabile - Non meno di 50 cm

- F** Misura dal muro
- G** Punto elettrico - 220V

ISTRUZIONI

UTILIZZARE IL TUO LAVAGGIO

LUXURY SINGLE WU/015
LUXURY DOUBLE WU/120 - WU/122 - WU/123
LUXURY TRIPLE WU/130
WU/132 - WU/133 - WU/134 - WU/135 - WU/136 - WU/137

Abbassa alzagambe, solleva schienale

Solleva alzagambe, reclinata schienale

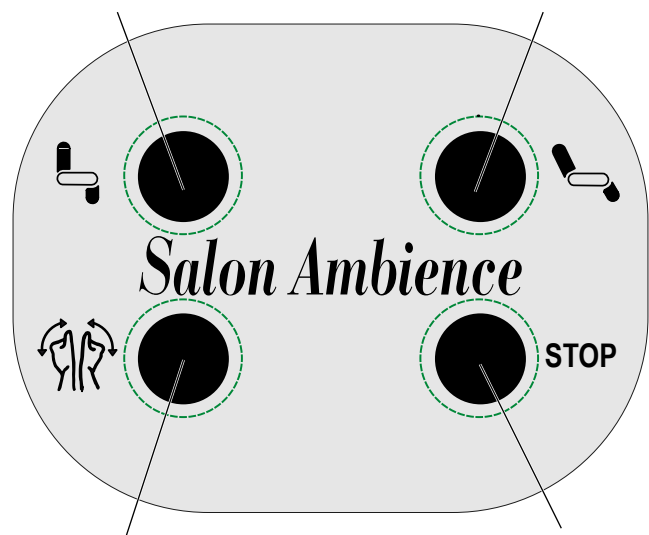

Inizio massaggio shiatsu
massaggio shiatsu

Ferma massaggio shiatsu



ISTRUZIONI

UTILIZZARE IL TUO LAVAGGIO

LUXURY SINGLE WU/016
LUXURY DOUBLE WU/121
LUXURY TRIPLE WU/131
WU/132 - WU/133 - WU/134
WU/135 - WU/136 - WU/137

Abbassa alzagambe, solleva schienale

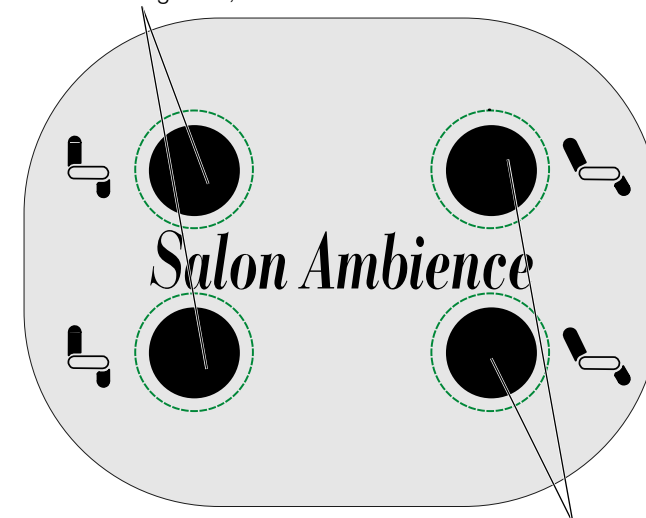

Solleva alzagambe, reclinata schienale



APPENDICE

MANUTENZIONE GENERALE

Ricordarsi sempre di scollegare il lavaggio dall'elettricità durante la riparazione, che deve essere effettuata da personale specializzato.

Verificare periodicamente che non ci siano perdite d'acqua nei collegamenti idrici, controllo che deve essere effettuato da personale specializzato.

Periodicamente controllare il fissaggio della ceramica per garantirne il corretto sostegno per il movimento.

PULIZIA

Quando si effettua la pulizia della tappezzeria, usare solo acqua e sapone neutro. Non usare mai prodotti a base di alcol per pulire il lavaggio.

OGNI SEI MESI ISPEZIONARE I RACCORDI DELL'IMPIANTO IDRICO E LA TELA GOMMATA DI STROFINAMENTO RUOTE MASSAGGIO ED EVENTUALMENTE, A SECONDO DELLA FREQUENZA DI UTILIZZO, LUBRIFICARLA CON GRASSO SINTETICO TIPO TOPAS NB 52.

AVVERTENZA

Non consentire ai bambini di giocare su questo lavaggio o di utilizzare il meccanismo. Il poggiatesta si ripiega verso il basso e il bambino potrebbe farsi male. Lasciare sempre in posizione verticale e chiuso. Tenere sempre mani e piedi fuori dal meccanismo.

Salon Ambience

Mod: ADVANTAGE⁺
REVOLUTION⁺/LUXURY

220-240 V 50/60 HZ 100W



Salon Ambience

LUXURY SINGLE WU/015 - WU/016
LUXURY DOUBLE WU/120 - WU/121
WU/122 - WU/123
LUXURY TRIPLE WU/130 - WU/131
WU/132 - WU/133
WU/134 - WU/135
WU/136 - WU/137

Contains information regarding installation and maintenance for the Salon Ambience Luxury shampoo units.

UK

INDEX

CHAPTER 1: INTRODUCTION

Introduction.....	15
About your shampoo unit.....	16

CHAPTER 2: INSTALLATION

Install your shampoo unit: Water Electricity.....	17
---------------------------------------------------	----

CHAPTER 3: INSTRUCTIONS

Using your shampoo unit: Luxury single WU/015.....	20
Luxury double WU/120 - WU/122 - WU/123.....	20
Luxury triple WU/130 - WU/132 - WU/133 - WU/134 - WU/135 - WU/136 - WU/137	20
Using your shampoo unit: Luxury single WU/016 - Luxury double WU/121.....	21
Luxury triple WU/131 - WU/132 - WU/133 - WU/134 - WU/135 - WU/136 - WU/137	21

APPENDIX

General maintenance.....	22
Cleaning.....	22
Technical characteristics.....	22
Declaration of conformity.....	63

INTRODUCTION

LUXURY SINGLE	WU/015 - WU/016
LUXURY DOUBLE	WU/120 - WU/121
	WU/122 - WU/123
LUXURY TRIPLE	WU/130 - WU/131
	WU/132 - WU/133
	WU/134 - WU/135
	WU/136 - WU/137

Thankyou for choosing this Salon Ambience shampoo unit - an excellent choice!

The stunning Luxury shampoo units from Salon Ambience offer amazing comfort and style - a refined, beautifully crafted shampoo unit that also includes an electric legrest, with a soft form that adds style to the salon, while still retaining the remarkable comfort expected of any Salon Ambience product.

The NEW SHIATSU® massage of the new LUXURY Salon Ambience washunit is specifically designed to relax the muscles and ease tension in the lumbar, sacrum and dorsal areas, leaving a feeling of lightness, tone and relaxation in the client. The massage works on four different pressure points and has a wider working surface than current shiatsu systems.

ABOUT YOUR SHAMPOO UNIT

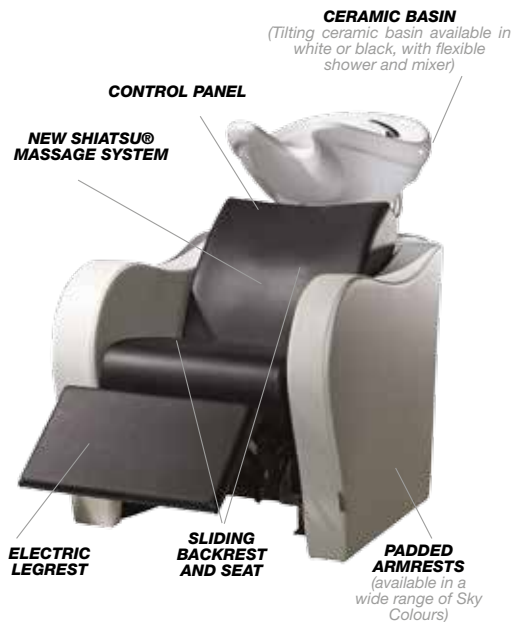

Available in a wide range of Sky Colours

INSTALLATION MEASUREMENTS

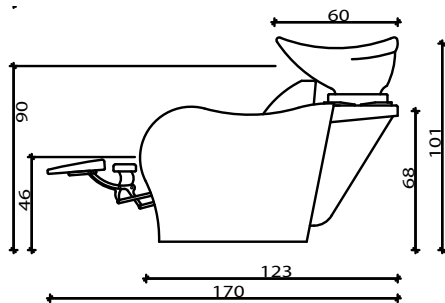

LUXURY SINGLE WU/015 - WU/016

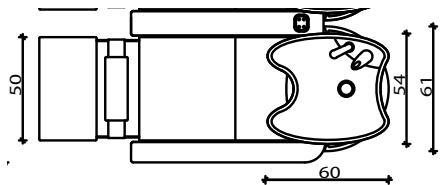

LUXURY DOUBLE WU/120 - WU/121 WU/122 - WU/123

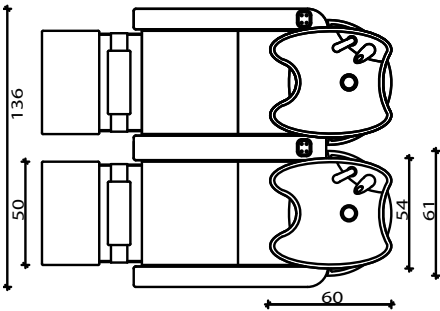

LUXURY TRIPLE WU/130 - WU/131 WU/132 - WU/133 WU/134 - WU/135 WU/136 - WU/137

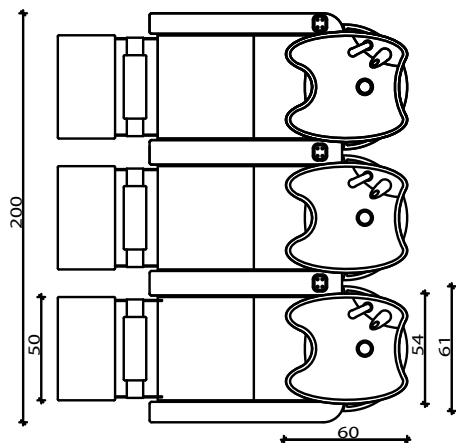

INSTALLATION

INSTALL YOUR SHAMPOO UNIT: WATER, ELECTRICITY

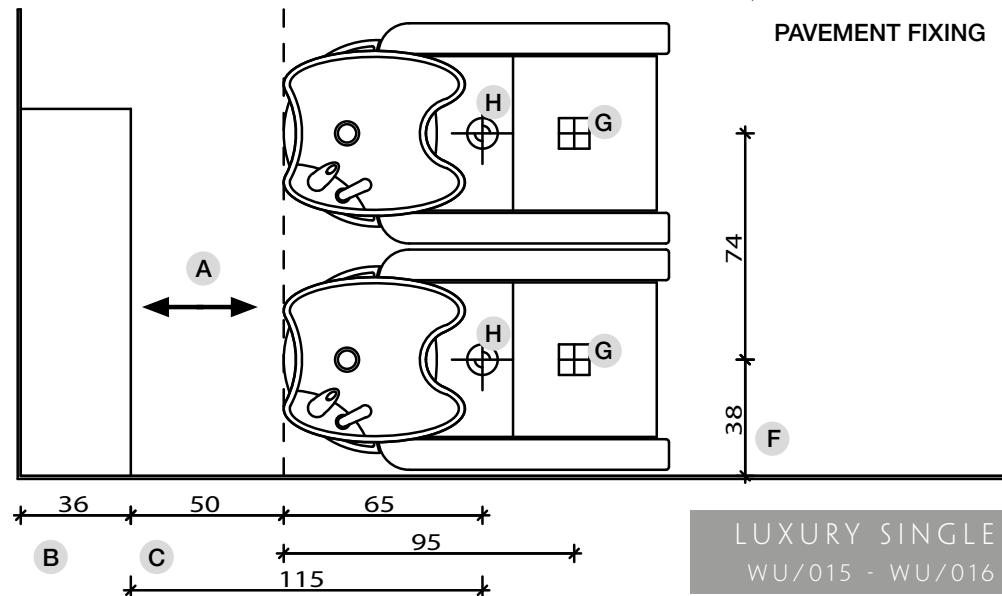

PAVEMENT FIXING

LUXURY SINGLE
WU/015 - WU/016

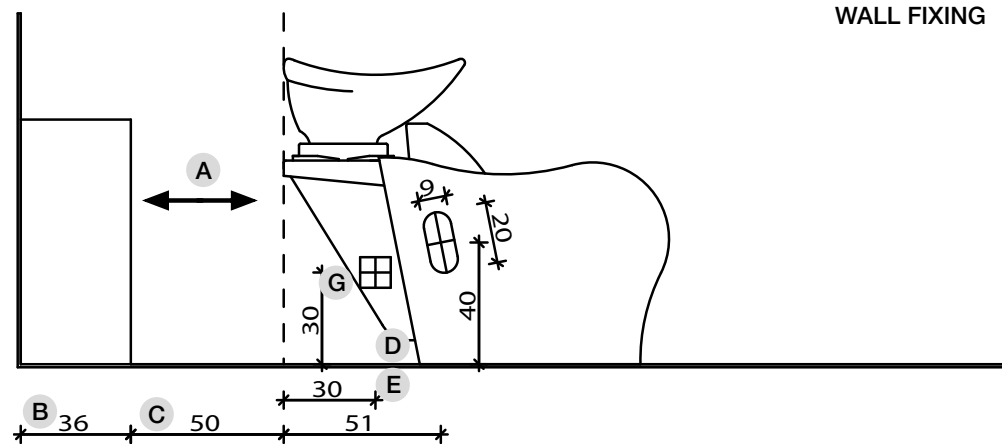

WALL FIXING

- A** Work space
- B** 36cm for 'Service Centre' cabinet
48cm for 'Wall System' cabinet
- C** Variable measurement - No less than 50 cm

- D** Hot and cold water inlet tube
- E** Water outlet tube
- F** Measurement from wall
- G** Electric point - 220V
- H** Water Inlet 3/8" - Outlet ø40

INSTALLATION

INSTALL YOUR SHAMPOO UNIT: WATER, ELECTRICITY

PAVEMENT FIXING

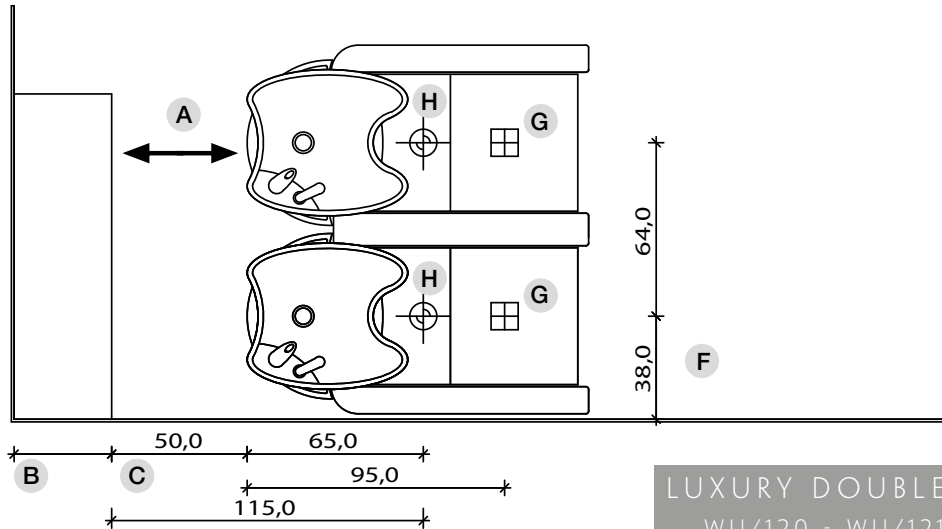

LUXURY DOUBLE
WU/120 - WU/121
WU/122 - WU/123

WALL FIXING

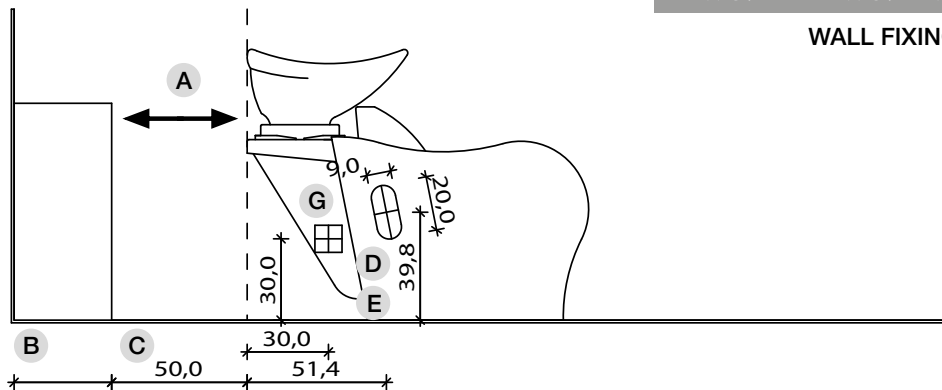

- A** Work space
- B** 36cm for 'Service Centre' cabinet
48cm for 'Wall System' cabinet
- C** Variable measurement - No less than 50 cm
- D** Hot and cold water inlet tube
- E** Water outlet tube
- F** Measurement from wall
- G** Electric point - 220V
- H** Water Inlet 3/8" - Outlet ø40

INSTALLATION

INSTALL YOUR SHAMPOO UNIT: WATER, ELECTRICITY

PAVEMENT FIXING

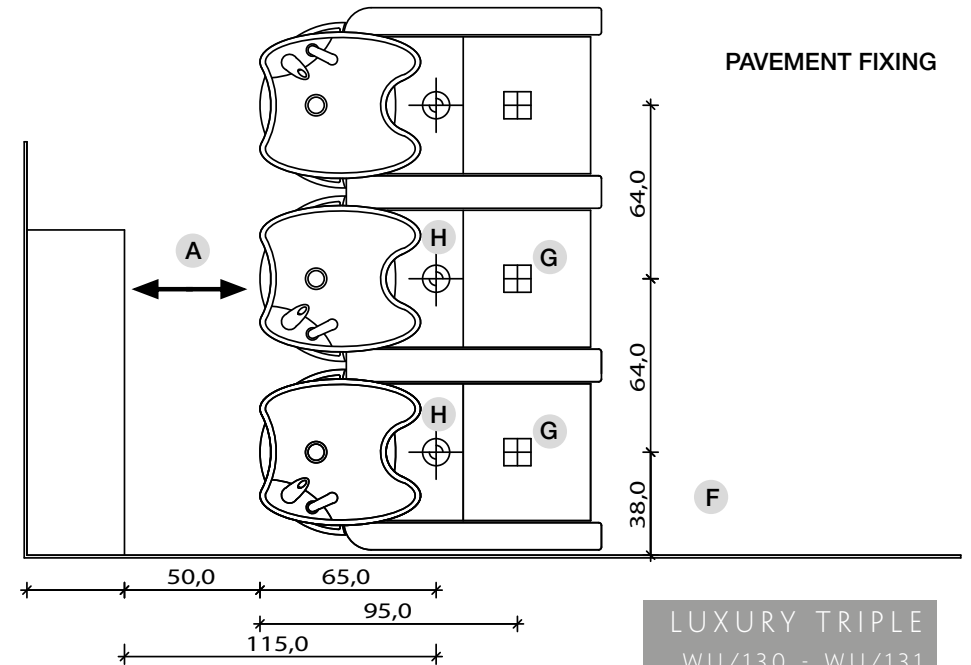

LUXURY TRIPLE
WU/130 - WU/131
WU/132 - WU/133
WU/134 - WU/135
WU/136 - WU/137

WALL FIXING

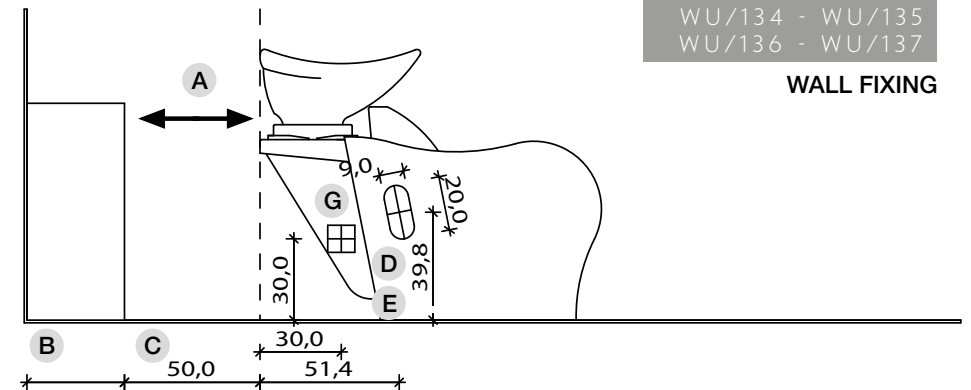

- A** Work space
- B** 36cm for 'Service Centre' cabinet
48cm for 'Wall System' cabinet
- C** Variable measurement - No less than 50 cm
- F** Measurement from wall
- G** Electric point - 220V

INSTRUCTIONS

LUXURY SINGLE WU/015
 LUXURY DOUBLE WU/120 - WU/122 - WU/123
 LUXURY TRIPLE WU/130
 WU/132 - WU/133 - WU/134 - WU/135 - WU/136 - WU/137

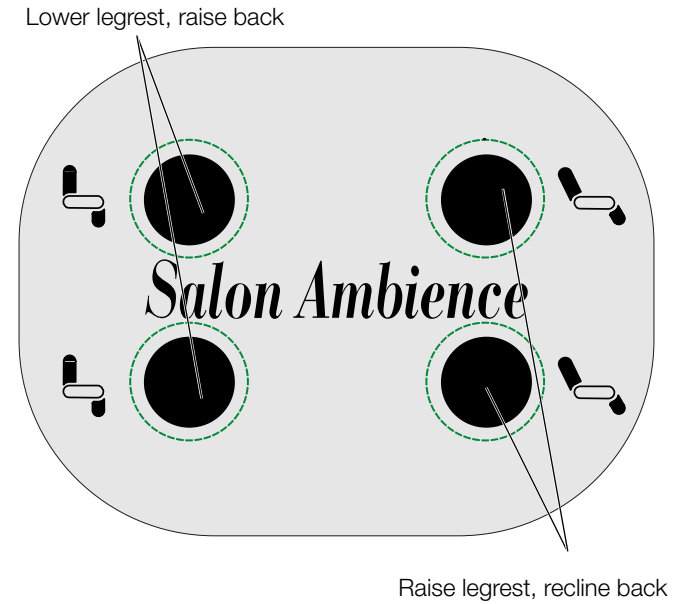
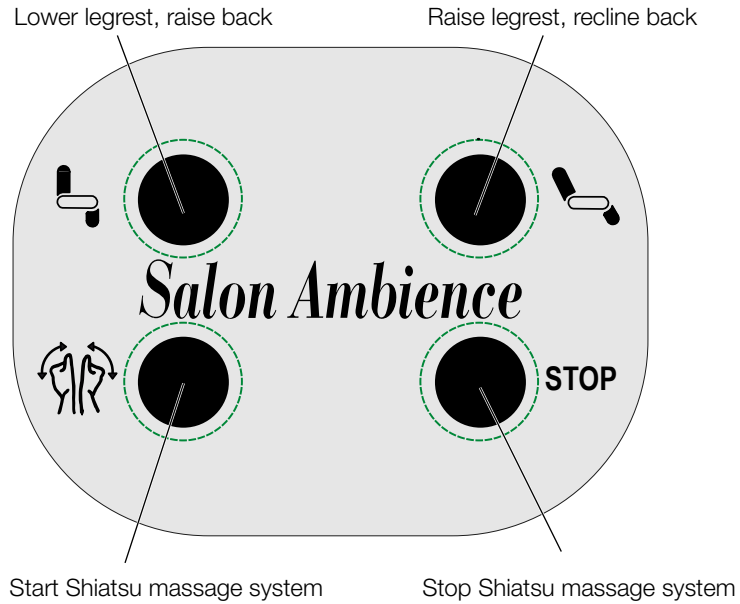

INSTRUCTIONS

LUXURY SINGLE WU/016
 LUXURY DOUBLE WU/121
 LUXURY TRIPLE WU/131
 WU/132 - WU/133 - WU/134
 WU/135 - WU/136 - WU/137

Shiatsu Massage



APPENDIX

GENERAL MAINTENANCE

Please remember to always disconnect the shampoo unit from the mains supply during any eventual repair, and always by authorised personnel.

Avoid leakage from arriving to the electric socket; occasionally check that all attachments are secure, and always by authorised personnel.

Occasionally check the basin fixing to ensure correct support and movement.

CLEANING

When cleaning upholstery, use only water and a neutral soap.

Never use alcohol-based products to clean the shampoo unit.

INSPECT WATER SYSTEM FITTINGS AND MASSAGE WHEEL RUBBER SHEET PROTECTION EVERY SIX MONTHS AND, DEPENDING ON FREQUENCY OF USE, LUBRICATE WITH A SYNTHETIC GREASE EG. TOPAS NB 52.

CAUTION

Do not allow children to play on this mechanised furniture or operate the mechanism. Legrest folds down on closing so that a child could possibly be injured. Always leave in an upright and closed position. Keep hands and feet clear of mechanism.

Salon Ambience

Mod: **ADVANTAGE⁺**
REVOLUTION⁺/LUXURY

220-240 V 50/60 HZ 100W



Salon Ambience

LUXURY SINGLE WU/015 - WU/016
LUXURY DOUBLE WU/120 - WU/121
WU/122 - WU/123
LUXURY TRIPLE WU/130 - WU/131
WU/132 - WU/133
WU/134 - WU/135
WU/136 - WU/137

Alle Informationen zur Installation und Unterhaltspflege der Salon Ambience Waschsesselmodelle Luxury.

DE

INHALT

KAPITEL 1: EINLEITUNG

Einleitung.....	25
Informationen zu Ihrem neuen Waschsessel.....	26

KAPITEL 2: MONTAGE

Wasserinstallation, Elektroinstallation.....	27
----------------------------------------------	----

KAPITEL 3: BEDIENUNGSANLEITUNG

Bedienung Ihres Waschsessels: Luxury single WU/015.....	30
Luxury double WU/120 - WU/122 - WU/123.....	30
Luxury triple WU/130 - WU/132 - WU/133 - WU/134 - WU/135 - WU/136 - WU/137	30
Bedienung Ihres Waschsessels: Luxury single WU/016 - Luxury double WU/12131	
Luxury triple WU/131 - WU/132 - WU/133 - WU/134 - WU/135 - WU/136 - WU/137	31

ANHANG

Unterhaltungspflege / Wartung.....	32
Reinigung.....	32
Technische Besonderheiten.....	32
Konformitätserklärung.....	63

EINLEITUNG

LUXURY SINGLE WU/015 - WU/016
LUXURY DOUBLE WU/120 - WU/121
WU/122 - WU/123
LUXURY TRIPLE WU/130 - WU/131
WU/132 - WU/133
WU/134 - WU/135
WU/136 - WU/137

**Vielen Dank, dass Sie sich für einen Salon Ambience
Waschsessel entschieden haben – eine gute Wahl!**

Das neue Salon Ambience Waschsesselmodell, Synthese aus Funktionalität, Kreativität und gelungenem Design, bietet mit synchron beweglichem Sitz- und Rückenpolster sowie ausschwenkbarer Beinauflage ein Optimum an Sitz- und Bedienungskomfort. Qualitätsmerkmale von Salon Ambience, made in Italy!

Die neue SHIATSU Massagetechnik des Salon Ambience Waschsessels Luxury bewirkt eine Entspannung der Muskulatur und löst Spannungen im Rücken-, Lendenwirbel- und Kreuzbeinbereich. Eine Massage mit diesem Waschsesselmodell verleiht dem Kunden ein relaxtes Gefühl von Leichtigkeit und ganzheitlicher Entspannung. Die SHIATSU Massage des Salon Ambience Waschsessels Luxury arbeitet an vier verschiedenen Druckpunkten und zeichnet sich durch eine größere Massageoberfläche als bei allen bisher bekannten Shiatsu-Systemen aus.

INFORMATIONEN ZU IHREM NEUEN WASCHSSEL



Erhältlich in einer breiten Palette von Sky Farben

MONTAGE MABE

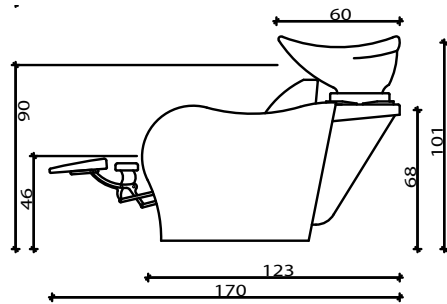

LUXURY SINGLE WU/015 - WU/016

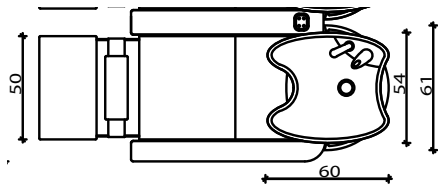

LUXURY DOUBLE WU/120 - WU/121 WU/122 - WU/123

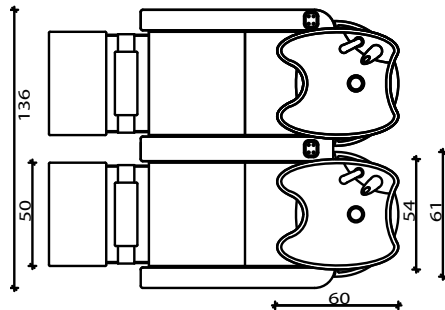

LUXURY TRIPLE WU/130 - WU/131 WU/132 - WU/133 WU/134 - WU/135 WU/136 - WU/137

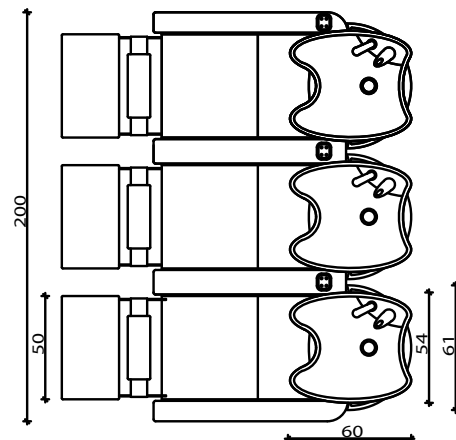

MONTAGE

WASSERINSTALLATION, ELEKTROINSTALLATION

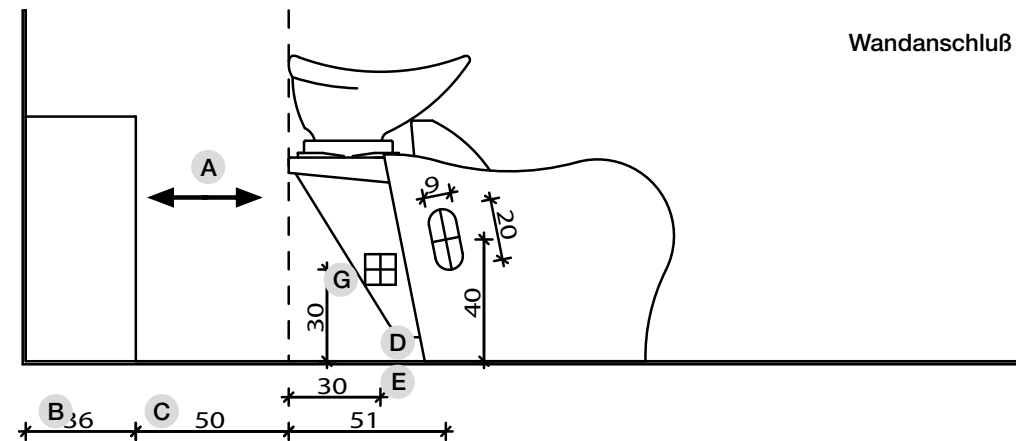
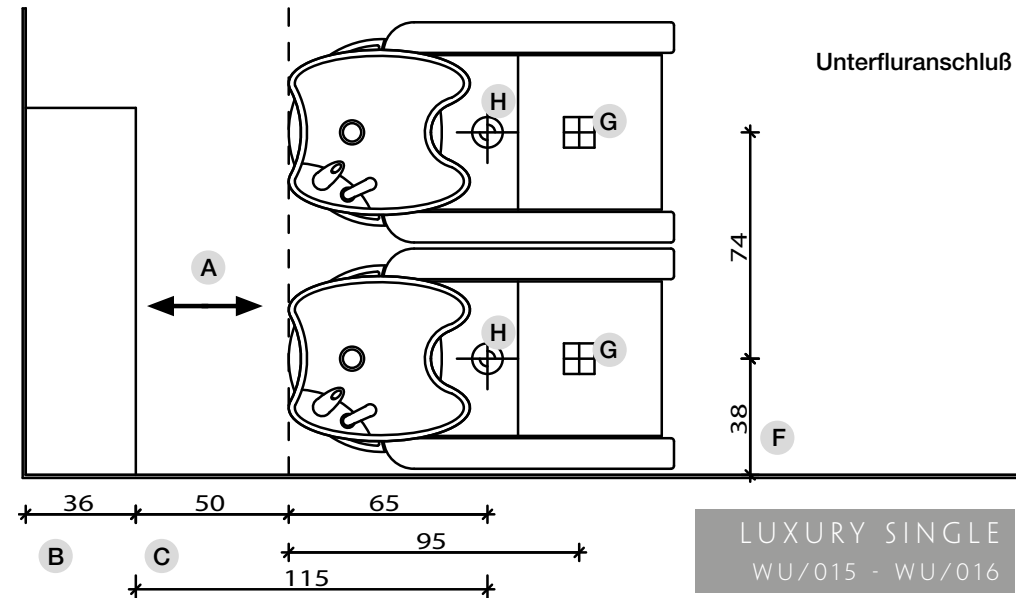

- A** Arbeitsraum
- B** Abstand von der Wand 36 cm "Service Centre"
Abstand von der Wand 48 cm "Wall System"
- C** Variabeles Maß – nicht unter 50cm
- D** Eingehende Warm- und Kaltwasserleitung
- E** Ausgang Wasserleitung
- F** Abstand von der Wand
- G** Wand: Steckdose
Bodenanschluß: Kabelausslass
Anschlußventile 3 / 8 "
Abfluss ø40
- H**

MONTAGE

WASSERINSTALLATION, ELEKTROINSTALLATION

Unterfluranschluß

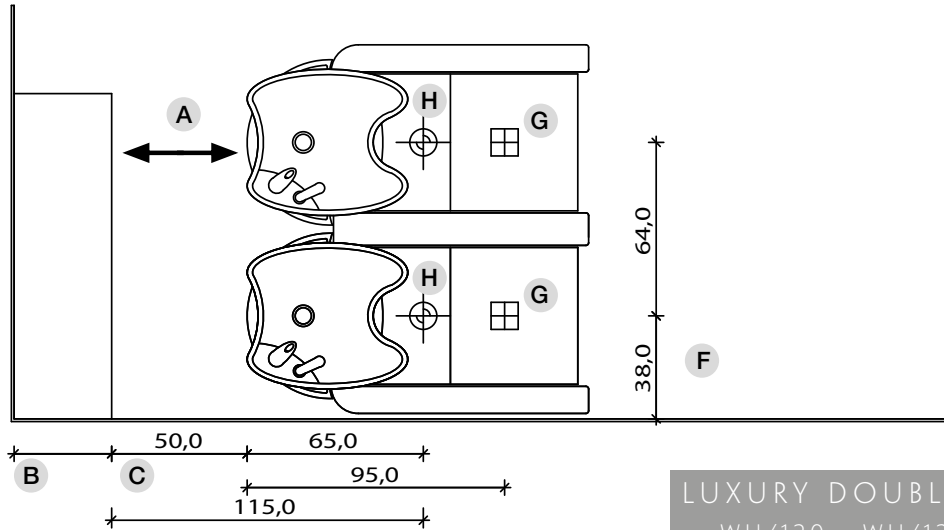

LUXURY DOUBLE
WU/120 - WU/121
WU/122 - WU/123

Wandanschluß

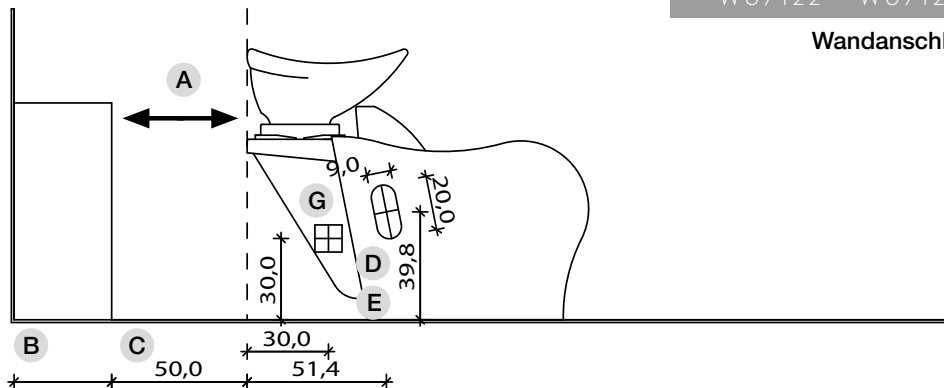

- A** Arbeitsraum
- B** Abstand von der Wand 36 cm "Service Centre"
Abstand von der Wand 48 cm "Wall System"
- C** Variabeles Maß – nicht unter 50cm
- D** Eingehende Warm- und Kaltwasserleitung
- E** Ausgang Wasserleitung
- F** Abstand von der Wand
- G** Wand: Steckdose
Bodenanschluß: Kabelauslass
- H** Anschlußventile 3 / 8 "
Abfluss ø40

MONTAGE

WASSERINSTALLATION, ELEKTROINSTALLATION

Unterfluranschluß

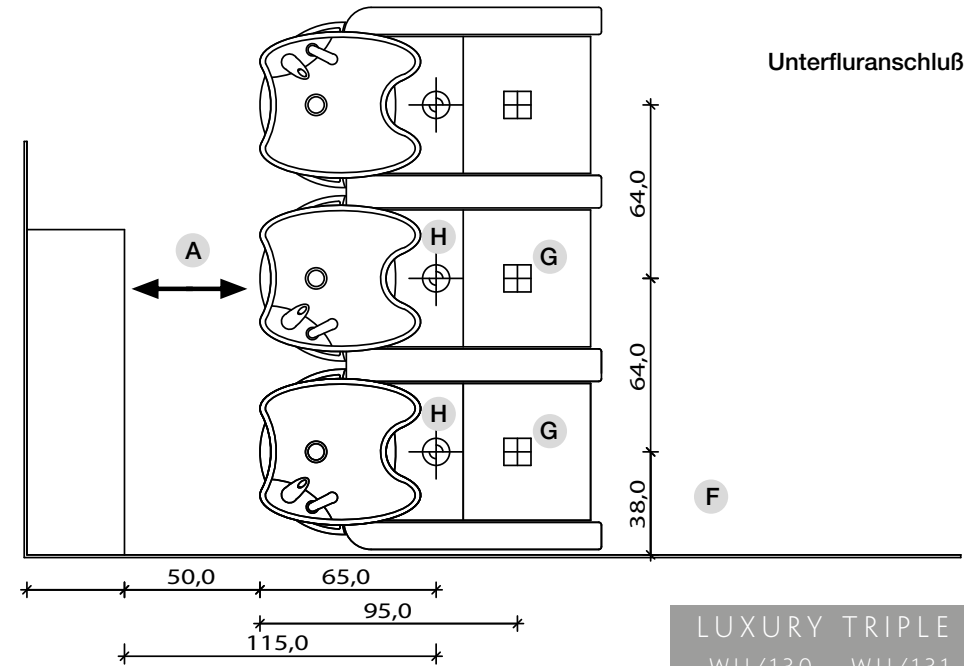

LUXURY TRIPLE
WU/130 - WU/131
WU/132 - WU/133
WU/134 - WU/135
WU/136 - WU/137

Wandanschluß

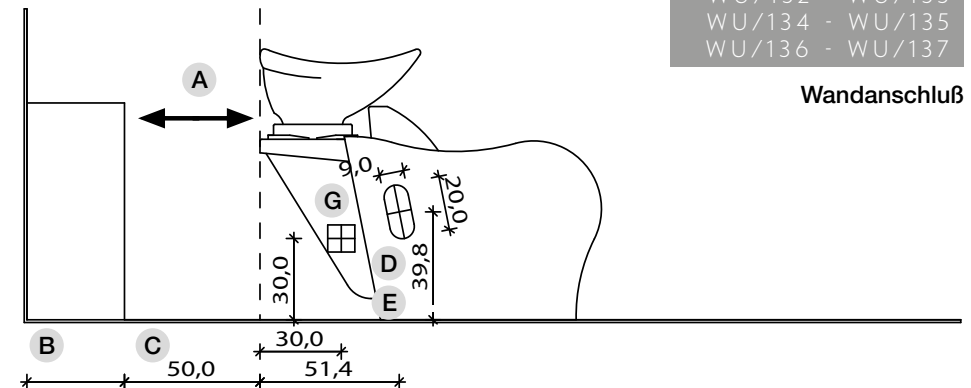

- A** Arbeitsraum
- B** Abstand von der Wand 36 cm "Service Centre"
Abstand von der Wand 48 cm "Wall System"
- C** Variabeles Maß – nicht unter 50cm
- F** Abstand von der Wand
- G** Wand: Steckdose
Bodenanschluß: Kabelauslass

BEDIENUNGSANLEITUNG

LUXURY SINGLE WU/015
 LUXURY DOUBLE WU/120 - WU/122 - WU/123
 LUXURY TRIPLE WU/130
 WU/132 - WU/133 - WU/134 - WU/135 - WU/136 - WU/137

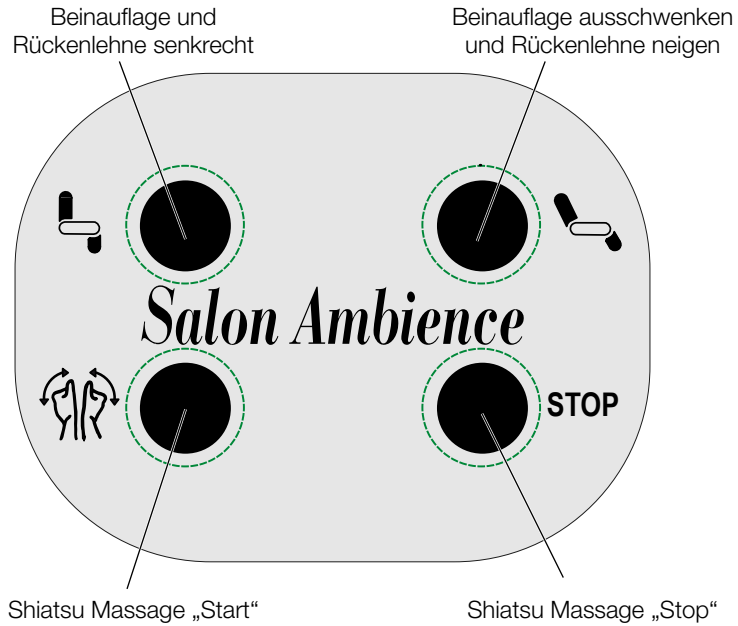

BEDIENUNGSANLEITUNG

LUXURY SINGLE WU/016
 LUXURY DOUBLE WU/121
 LUXURY TRIPLE WU/131
 WU/132 - WU/133 - WU/134
 WU/135 - WU/136 - WU/137

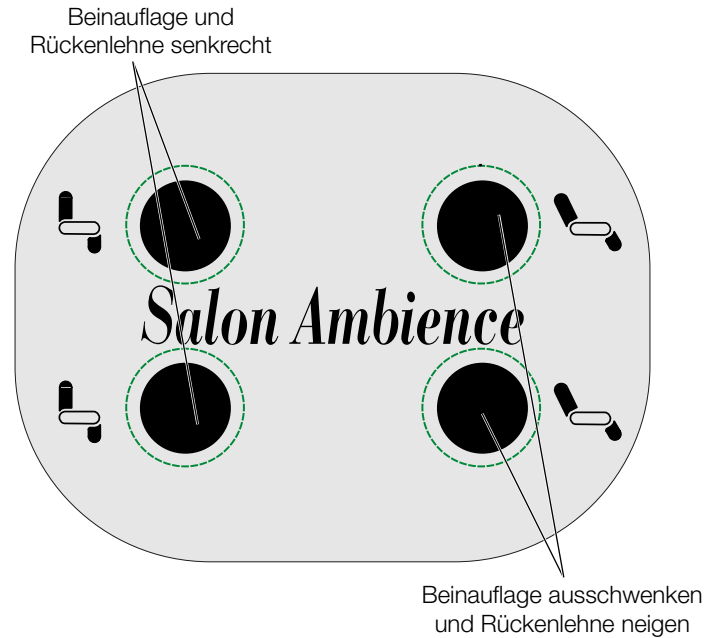

Shiatsu Massage



ANHANG

UNTERHALTSPFLEGE / WARTUNG

Vor Beginn von Reparaturarbeiten, die ausschließlich von autorisierten Personen vorgenommen werden dürfen, ist die Stromversorgung zu unterbrechen. Stellen Sie sicher, dass z.B. durch eine auftretende Undichtigkeit kein Wasser in die Steckdose gelangen kann. Frisch- und Abwasserverbindungen sind regelmäßig auf festen Sitz und Dichtheit von ausschließlich autorisierten Personen zu überprüfen. Die Beckenbefestigung, die Kippmechanik und Wasser-/ Abwasserverbindungen sind regelmäßig auf festen Sitz und einwandfreie Kippfunktion des Beckens zu überprüfen.

REINIGUNG / PFLEGE

Polsterreinigung mit weichem Schwamm, lauwarmen Wasser und Neutralseife. Keine Gewährleistung / Garantieleistung bei Verfärbung durch Übertragung von Textilfarben (z.B. Jeans), Haarfarbe u.s.w. oder unsachgemäße Polsterpflege mit alkohol-, lösungs-, scheuermittel- oder wachshaltigen Reinigungsmitteln!

REGELMÄSSIGE KONTROLLE DER WASSER- UND ABWASSERFÜHRENDEN LEITUNGEN UND DER MISCHBATTERIE SOWIE DES MASSAGESYSTEMS. JE NACH NUTZUNGSINTENSITÄT, SPÄTESTENS JEDOCH HALBJÄHRLICH, IST DAS EINFETTEN DER MASSAGEROLLENLAUFFLÄCHEN MIT SÄUREFREIEM, SYNTHETISCHEM FETT ERFORDERLICH.

WARNUNG

Achten Sie darauf, dass Kinder nicht an der Mechanik des Waschsessels spielen und die Mechanik der Beinauflage in Gang setzen. Insbesondere der Scherenmechanismus zum Ein- und Ausschwenken der Beinauflage stellt bei Betrieb eine besondere Verletzungsgefahr dar. Ausschließlich das Salonpersonal sollte die Bedienung der Mechanik vornehmen.

Salon Ambience

Mod: ADVANTAGE⁺
REVOLUTION⁺/LUXURY

220-240 V 50/60 HZ 100W



Salon Ambience

LUXURY SINGLE WU/015 - WU/016
LUXURY DOUBLE WU/120 - WU/121
WU/122 - WU/123
LUXURY TRIPLE WU/130 - WU/131
WU/132 - WU/133
WU/134 - WU/135
WU/136 - WU/137

Contient des informations sur l'installation et de la maintenance pour le mobilier de coiffure Revolution de la marque Salon Ambience.

FR

SOMMAIRE

CHAPITRE 1: INTRODUCTION

Introduction.....	35
Au sujet de votre mobilier de coiffure.....	36

CHAPITRE 2: INSTALLATION

Installation du mobilier de coiffure: Eau, Electricité.....	37
-------------------------------------------------------------	----

CHAPITRE 3: INSTRUCTION

Utilisation du mobilier de coiffure: Luxury single WU/015.....	40
Luxury double WU/120 - WU/122 - WU/123.....	40
Luxury triple WU/130 - WU/132 - WU/133 - WU/134 - WU/135 - WU/136 - WU/137	40
Utilisation du mobilier de coiffure: Luxury single WU/016 - Luxury double WU/121	41
Luxury triple WU/131 - WU/132 - WU/133 - WU/134 - WU/135 - WU/136 - WU/137	41

ANNEXE :

Maintenance Générale.....	42
Entretien.....	42
Caractéristiques générales.....	42
Déclaration de conformité.....	63

INTRODUCTION

LUXURY SINGLE WU/015 - WU/016
LUXURY DOUBLE WU/120 - WU/121
WU/122 - WU/123
LUXURY TRIPLE WU/130 - WU/131
WU/132 - WU/133
WU/134 - WU/135
WU/136 - WU/137

**Merci d'avoir choisi le mobilier de coiffure
Salon Ambience ; C'est un excellent choix!**

Le nouveau bac de lavage Luxury de Salon Ambience offre un confort et un style extraordinaire, il est caractérisé par des détails très raffinés et un repose-pieds électrique et surtout par le massage NEW SHIATSU® de nouvelle génération. Sa forme incurvée ajoute du style au salon en gardant le confort caractéristique de tous les produits Salon Ambience.

Le massage NEW SHIATSU® du nouveau bac lavage Luxury de Salon Ambience est spécifiquement conçu pour détendre les muscles et apaiser les tensions dans la région lombaire, le sacrum et les régions dorsales, laissant une sensation de légèreté, de relaxation. Le massage travaille sur quatre points de pression et à une plus grande surface de travail que les systèmes actuels de shiatsu.

AU SUJET DE VOTRE MOBILIER DE COIFFURE



Disponible dans une large gamme de couleurs Sky

INSTALLATION LES MESURES

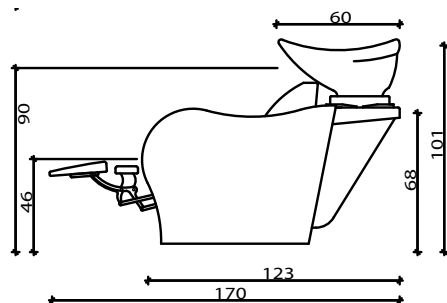

LUXURY SINGLE WU/015 - WU/016

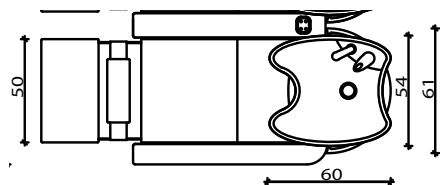

LUXURY DOUBLE WU/120 - WU/121 WU/122 - WU/123

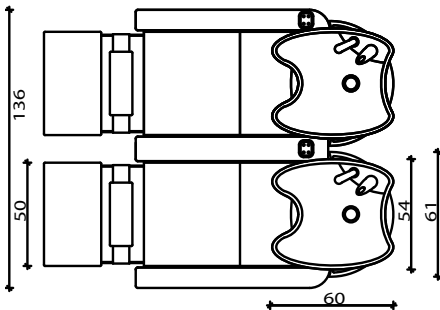

LUXURY TRIPLE WU/130 - WU/131 WU/132 - WU/133 WU/134 - WU/135 WU/136 - WU/137

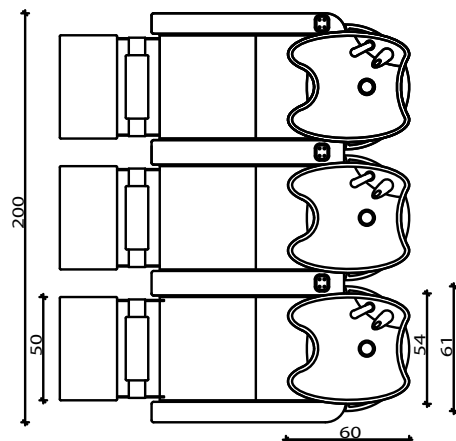

INSTALLATION

INSTALLATION DU MOBILIER DE COIFFURE: EAU, ELECTRICITÉ

RELIÉ AU SOL

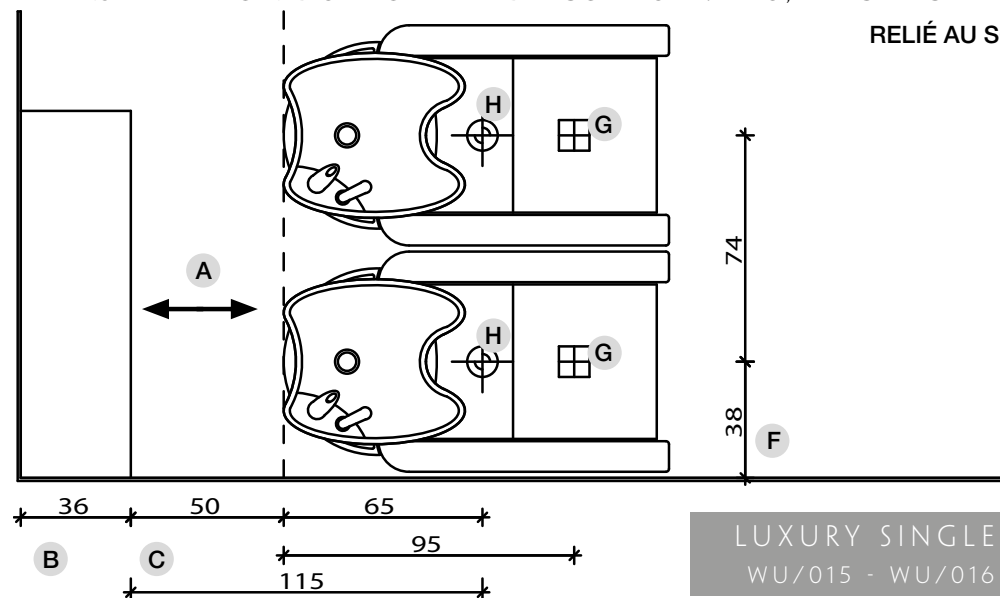

LUXURY SINGLE
WU/015 - WU/016

RELIÉ AU MUR

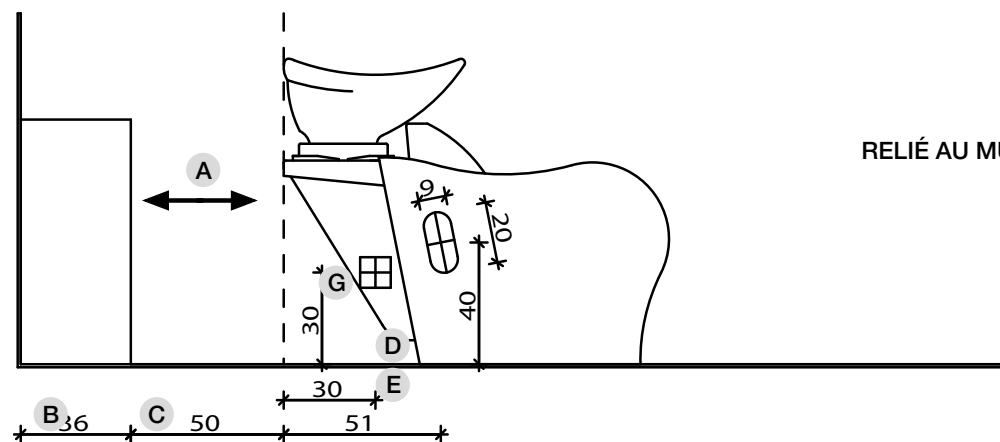

- A** Espace de travail
- B** 36 cm pour le cabinet 'Service Centre'
48 cm pour le cabinet 'Wall System'
- C** Différentes mesures- pas moins de 50cm
- D** Entrant tuyau d'eau chaude et froide
- E** Tuyau d'eau de sortie
- F** Mesures à partir du mur
- G** Point électrique - 220V
- H** Remplissage d'eau 3 / 8 "
Echappement ø40

INSTALLATION

INSTALLATION DU MOBILIER DE COIFFURE: EAU, ELECTRICITÉ

RELIÉ AU SOL

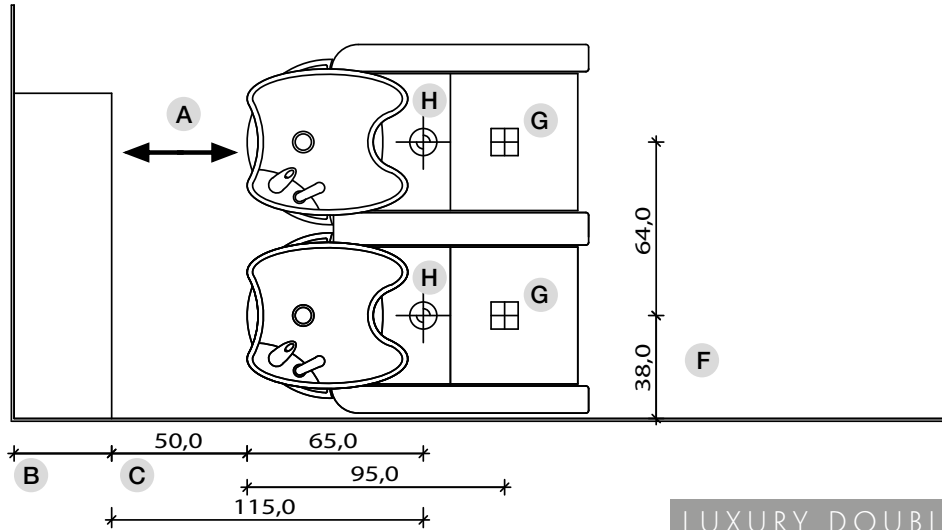

LUXURY DOUBLE

WU/120 - WU/121
WU/122 - WU/123

RELIÉ AU MUR

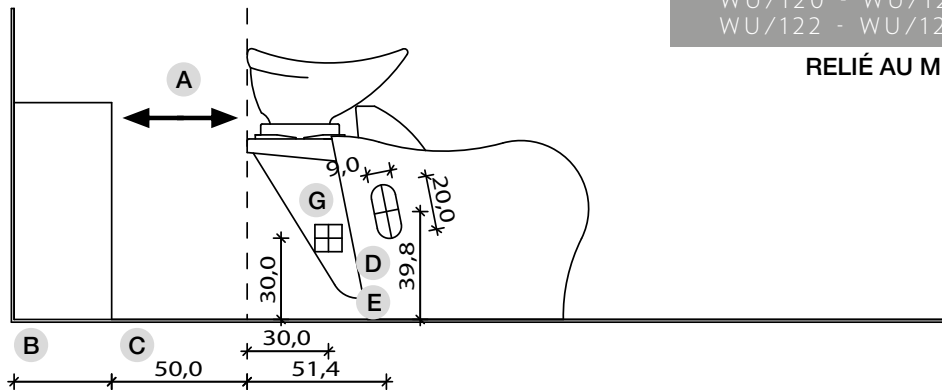

A Espace de travail

B 36 cm pour le cabinet 'Service Centre'
48 cm pour le cabinet 'Wall System'

C Différentes mesures- pas moins de 50cm

D Entrant tuyau d'eau chaude et froide

E Tuyau d'eau de sortie

F Mesures à partir du mur

G Point électrique - 220V

H Remplissage d'eau 3 / 8 "
Echappement ø40

INSTALLATION

INSTALLATION DU MOBILIER DE COIFFURE: EAU, ELECTRICITÉ

RELIÉ AU SOL

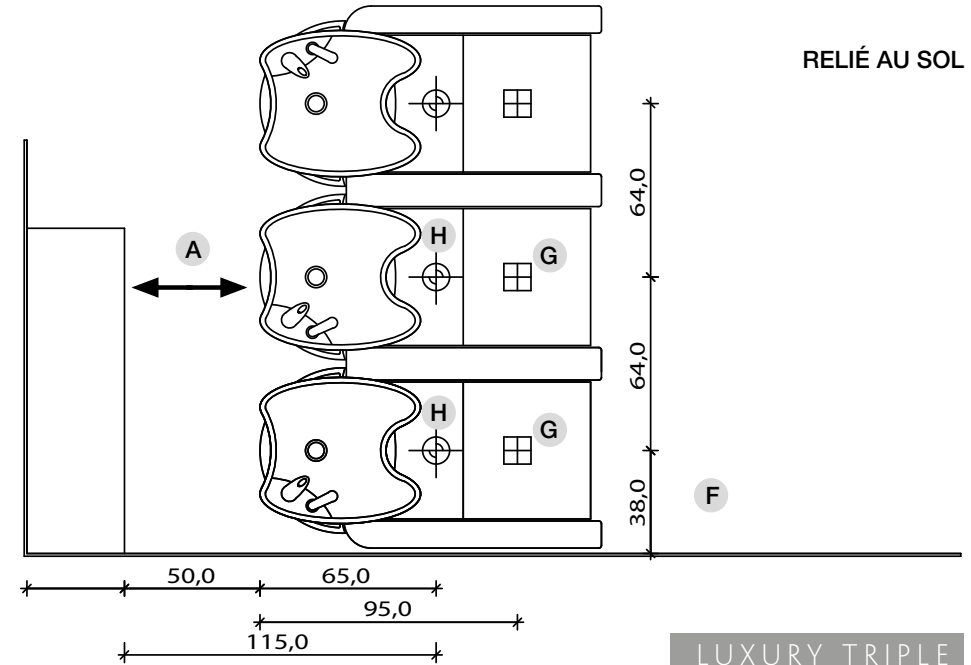

LUXURY TRIPLE

WU/130 - WU/131
WU/132 - WU/133
WU/134 - WU/135
WU/136 - WU/137

RELIÉ AU MUR

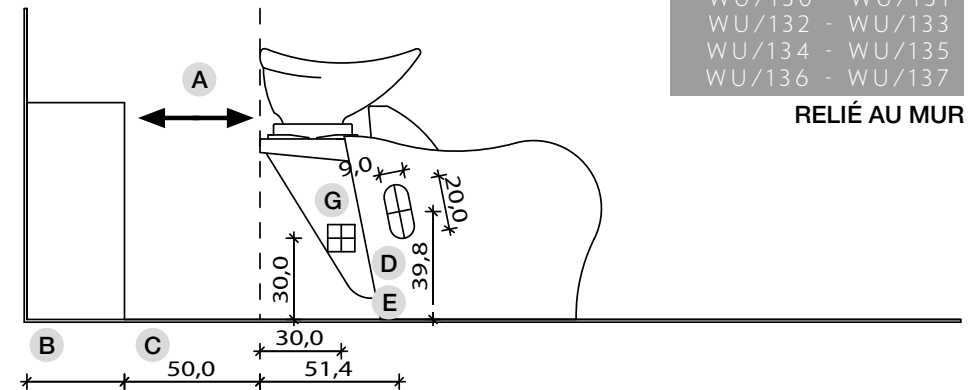

A Espace de travail

B 36 cm pour le cabinet 'Service Centre'
48 cm pour le cabinet 'Wall System'

C Différentes mesures- pas moins de 50cm

F Mesures à partir du mur

G Point électrique - 220V

INSTRUCTION

LUXURY SINGLE WU/015
 LUXURY DOUBLE WU/120 - WU/122 - WU/123
 LUXURY TRIPLE WU/130
 WU/132 - WU/133 - WU/134 - WU/135 - WU/136 - WU/137

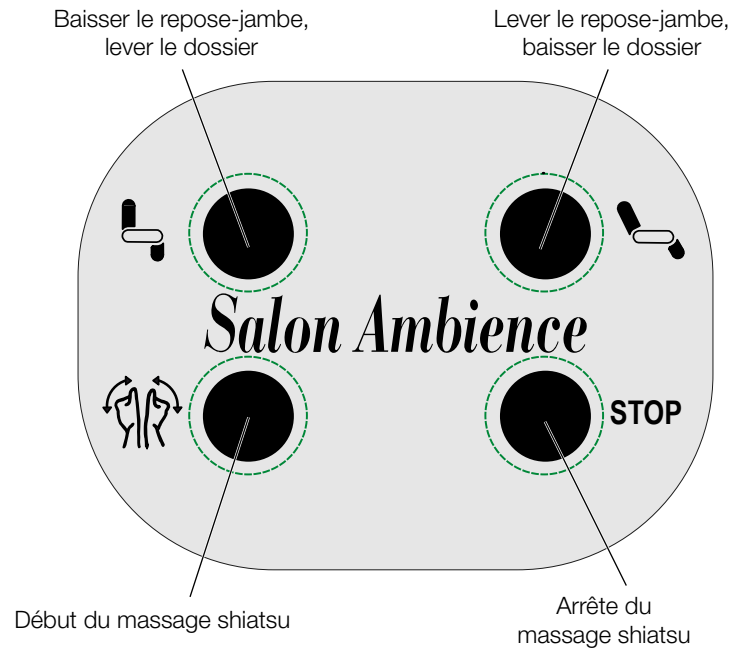

INSTRUCTION

LUXURY SINGLE WU/016
 LUXURY DOUBLE WU/121
 LUXURY TRIPLE WU/131
 WU/132 - WU/133 - WU/134
 WU/135 - WU/136 - WU/137

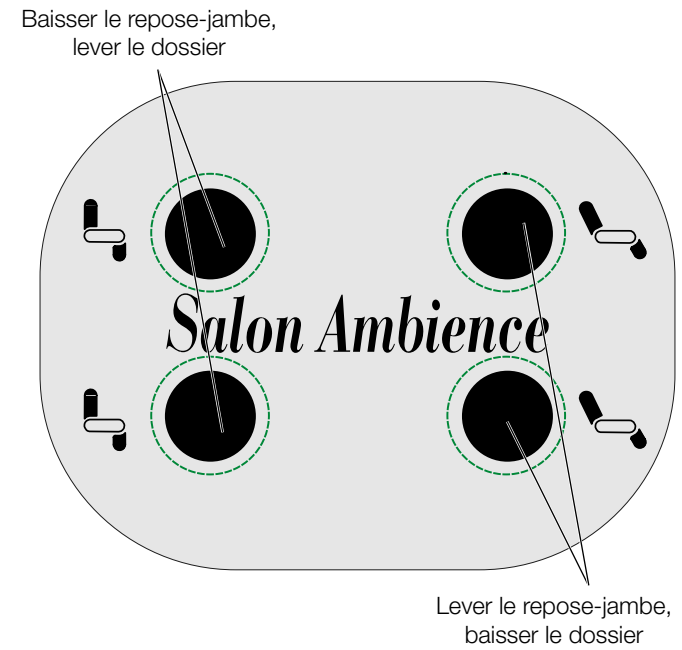

massage shiatsu



ANNEXE

MAINTENANCE GÉNÉRALE

Veillez vous rappeler, qu'il est important de toujours débrancher l'unité d'alimentation de votre mobilier de coiffure lors de n'importe quelle réparation par un personnel compétent.

Afin d'éviter des fuites d'eau jusqu'à la douille électrique, vérifier de temps en temps que tous les raccordements soient bien sécurisés par le biais d'un personnel compétent.

Vérifier de temps en temps la fixation du support de la cuvette pour assurer un mouvement correct.

NETTOYAGE

Quand on veut nettoyer la tapisserie il faut utiliser seulement de l'eau et du savon.

N'utiliser jamais des produits avec alcool pour nettoyer le bac lavage.

TOUTS LES SIX MOIS CONTRÔLER LES RACCORDEMENTS DU SYSTÈME DE L'EAU ET LA TOILE GOMMÉ DES ROULETTES DE MASSAGE ET ÉVENTUELLEMENT, SELON LA FRÉQUENCE D'EMPLOIE, LA LUBRIFIER AVEC GRAISSE SYNTHÉTIQUE DU TYPE TOPAS NB 52.

AVERTISSEMENT:

Ces mobiliers spécifiques ne sont pas adaptés aux enfants, jouer avec le mécanisme du fauteuil peut être dangereux. Toujours rester dans une position droite et détendue. Garder les mains et les pieds hors du mécanisme. Ce mobilier de coiffure est seulement adapté aux clients du salon.

Salon Ambience

Mod: **ADVANTAGE⁺**
REVOLUTION⁺/LUXURY

220-240 V 50/60 HZ 100W



Salon Ambience

LUXURY SINGLE WU/015 - WU/016

LUXURY DOUBLE WU/120 - WU/121

WU/122 - WU/123

LUXURY TRIPLE WU/130 - WU/131

WU/132 - WU/133

WU/134 - WU/135

WU/136 - WU/137

Contiene información para la instalación y el mantenimiento de los lavacabezas Luxury de Salon Ambience.

ES

INDICE

CAPITULO 1: INTRODUCCION

Introducción.....	45
Información del lavacabezas.....	46

CAPITULO 2: INSTALACION

Instalación del lavacabezas: Fontanería, Electricidad.....	47
------------------------------------------------------------	----

CAPITULO 3: INSTRUCCIONES

Uso del lavacabezas: Luxury single WU/015.....	50
Luxury double WU/120 - WU/122 - WU/123.....	50
Luxury triple WU/130 - WU/132 - WU/133 - WU/134 - WU/135 - WU/136 - WU/137	50
Uso del lavacabezas:Luxury single WU/016 - Luxury double WU/121.....	51
Luxury triple WU/131 - WU/132 - WU/133 - WU/134 - WU/135 - WU/136 - WU/137	51

APENDICE

Mantenimiento general.....	52
Limpieza.....	52
Características técnicas.....	52
Declaración de conformidad.....	63

INTRODUCCION

LUXURY SINGLE WU/015 - WU/016
LUXURY DOUBLE WU/120 - WU/121
WU/122 - WU/123
LUXURY TRIPLE WU/130 - WU/131
WU/132 - WU/133
WU/134 - WU/135
WU/136 - WU/137

Felicidades por haber elegido este lavacabezas Salon Ambience - una excelente elección!

El extraordinario lavacabezas Luxury de Salon Ambience ofrece un sorprendente estilo y confort; elegante y cuidadosamente diseñado, está provisto de apoya piernas eléctrico y un sistema de masaje NEW SHIATSU de nueva generación. Su forma curvada añade carácter al salón, manteniendo al mismo tiempo el extraordinario confort de todos los productos Salon Ambience.

El masaje NEW SHIATSU del nuevo lavacabezas Luxury de Salon Ambience está específicamente diseñado para relajar los músculos y aliviar la tensión de la zona lumbar, sacra y dorsal, dejando una sensación de ligereza, tonicidad y relajación en el cliente. El masaje trabaja en cuatro puntos diferentes de presión equilibrada y tiene una superficie de trabajo más amplia que las versiones hasta ahora utilizadas.

INFORMACION DEL LAVACABEZAS

Disponible en una amplia gama de Sky Colours



INSTALACION MEDIDAS

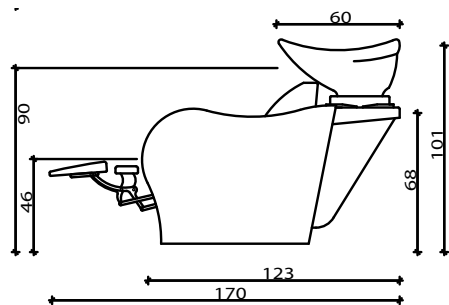

LUXURY SINGLE WU/015 - WU/016

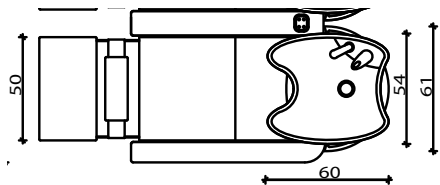

LUXURY DOUBLE WU/120 - WU/121 WU/122 - WU/123

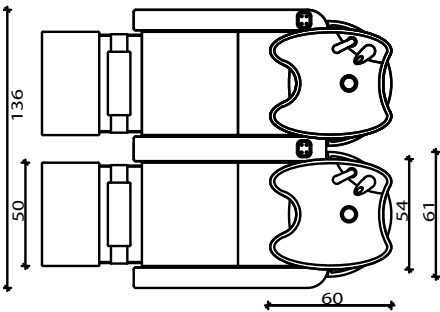

LUXURY TRIPLE WU/130 - WU/131 WU/132 - WU/133 WU/134 - WU/135 WU/136 - WU/137

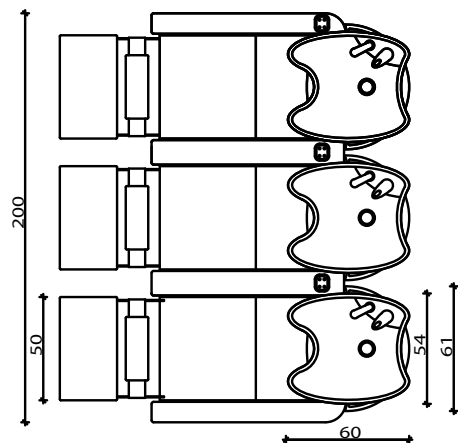

INSTALACION

INSTALACION DEL LAVACABEZAS: FONTANERIA , ELECTRICIDAD

MONTAJE EN EL SUELO

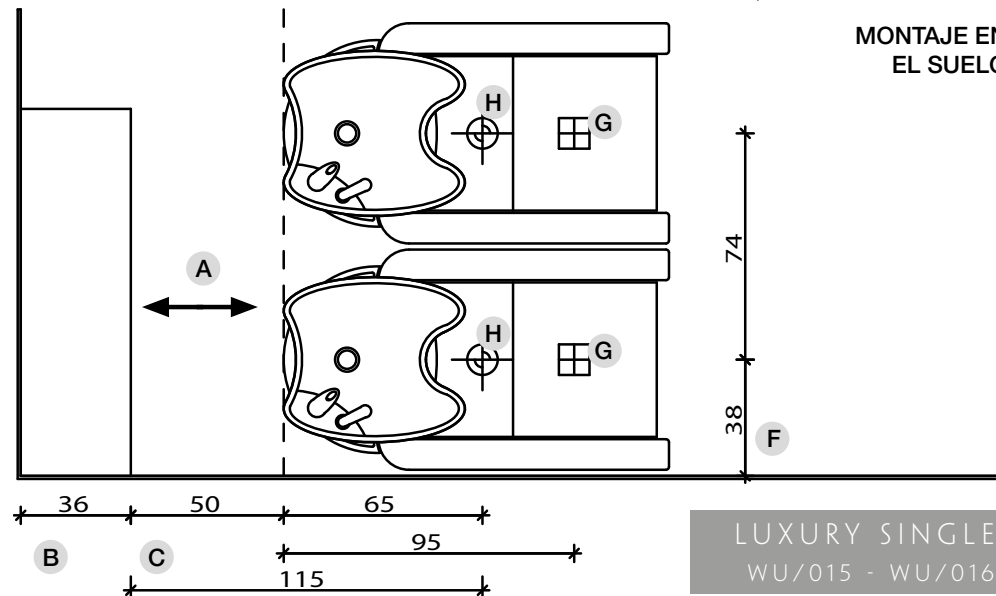

LUXURY SINGLE
WU/015 - WU/016

MONTAJE EN LA PARED

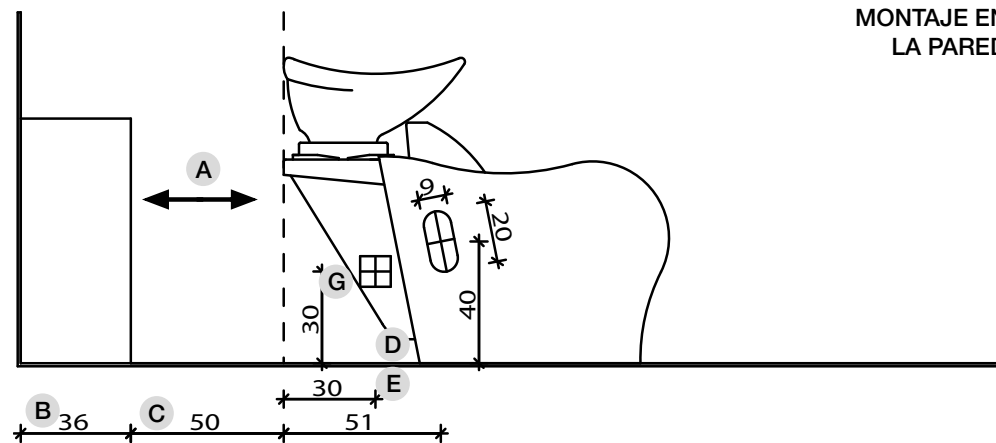

- A** Zona de trabajo
- B** 36 cm medida del mueble "Service Center"
48 cm medida del mueble "Wall System"
- C** Medida variable - Nunca inferior a 50 cm.
- D** Entrada de agua caliente y fría
- E** Salida tubo desague
- F** Medida desde la pared
- G** Punto eléctrico 220V
- H** Entrada de agua 3/8"
Tubo desague diam. 40

INSTALACION

INSTALACION DEL LAVACABEZAS: FONTANERIA , ELECTRICIDAD

MONTAJE EN EL SUELO

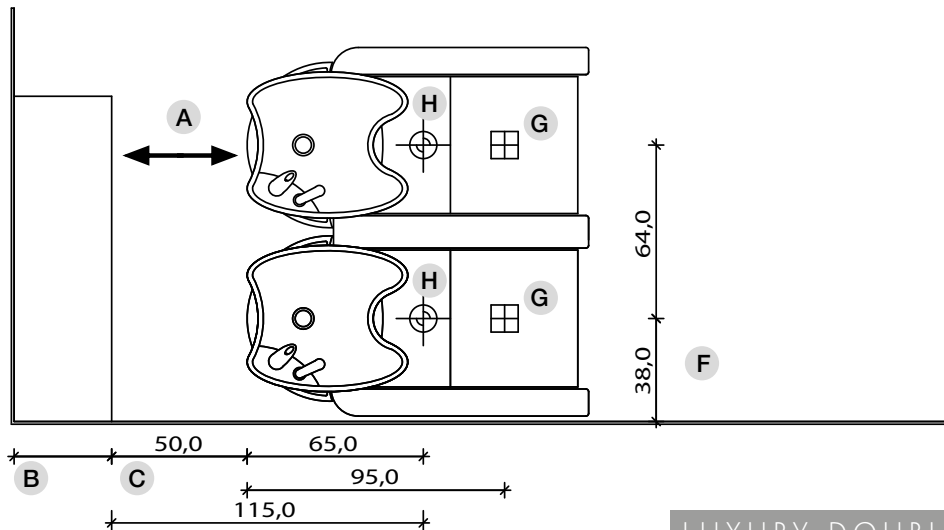

LUXURY DOUBLE

WU/120 - WU/121
WU/122 - WU/123

MONTAJE EN LA PARED

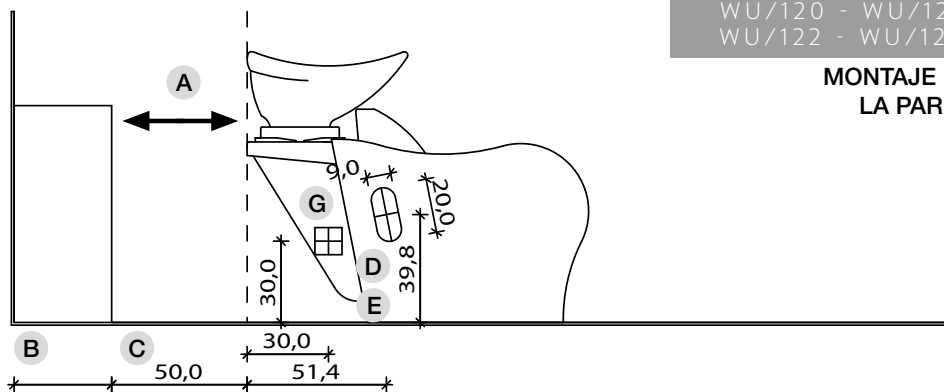

A Zona de trabajo

B 36 cm medida del mueble "Service Center"
48 cm medida del mueble "Wall System"

C Medida variable - Nunca inferior a 50 cm.

D Entrada de agua caliente y fría

E Salida tubo desague

F Medida desde la pared

G Punto eléctrico 220V

H Entrada de agua 3/8"
Tubo desague diam. 40

INSTALACION

INSTALACION DEL LAVACABEZAS: FONTANERIA , ELECTRICIDAD

MONTAJE EN EL SUELO

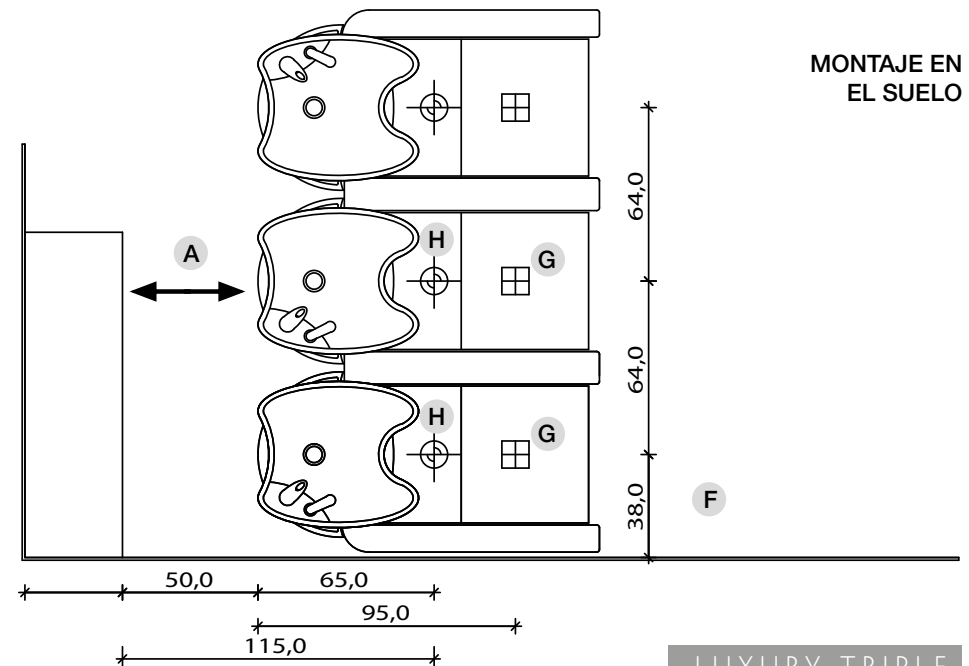

LUXURY TRIPLE

WU/130 - WU/131
WU/132 - WU/133
WU/134 - WU/135
WU/136 - WU/137

MONTAJE EN LA PARED

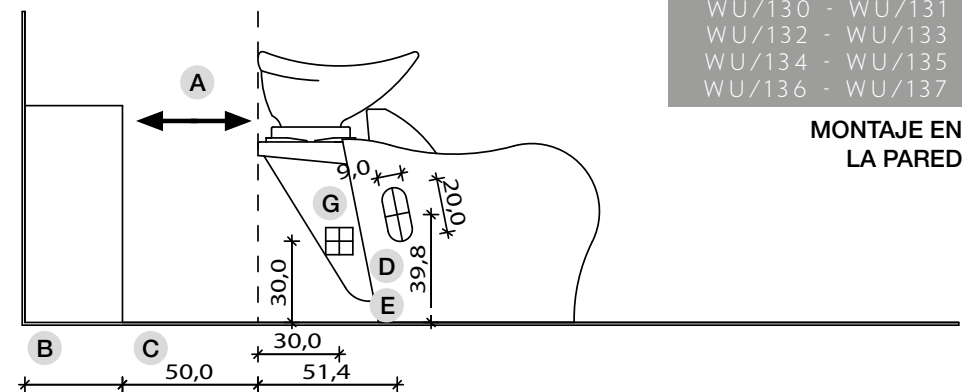

A Zona de trabajo

B 36 cm medida del mueble "Service Center"
48 cm medida del mueble "Wall System"

C Medida variable - Nunca inferior a 50 cm.

F Medida desde la pared

G Punto eléctrico 220V

INSTRUCCIONES

LUXURY SINGLE WU/015
 LUXURY DOUBLE WU/120 - WU/122 - WU/123
 LUXURY TRIPLE WU/130
 WU/132 - WU/133 - WU/134 - WU/135 - WU/136 - WU/137

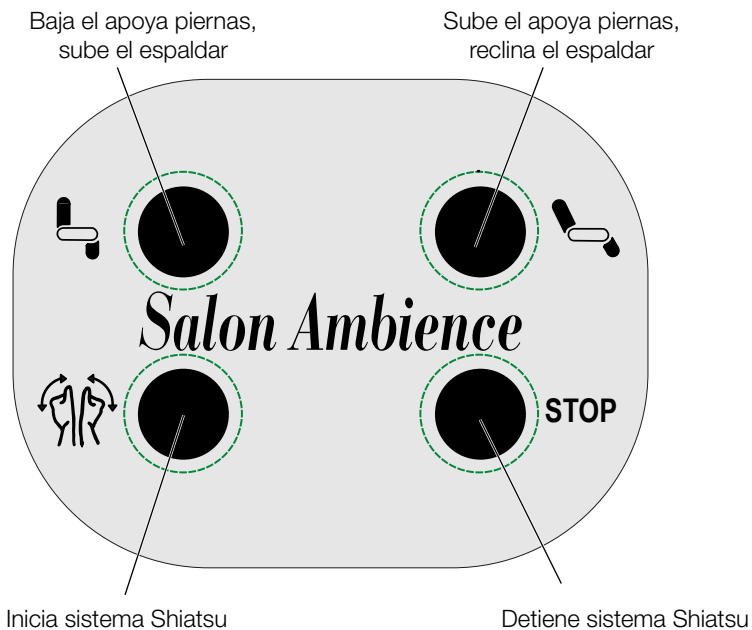

INSTRUCCIONES

LUXURY SINGLE WU/016
 LUXURY DOUBLE WU/121
 LUXURY TRIPLE WU/131
 WU/132 - WU/133 - WU/134
 WU/135 - WU/136 - WU/137

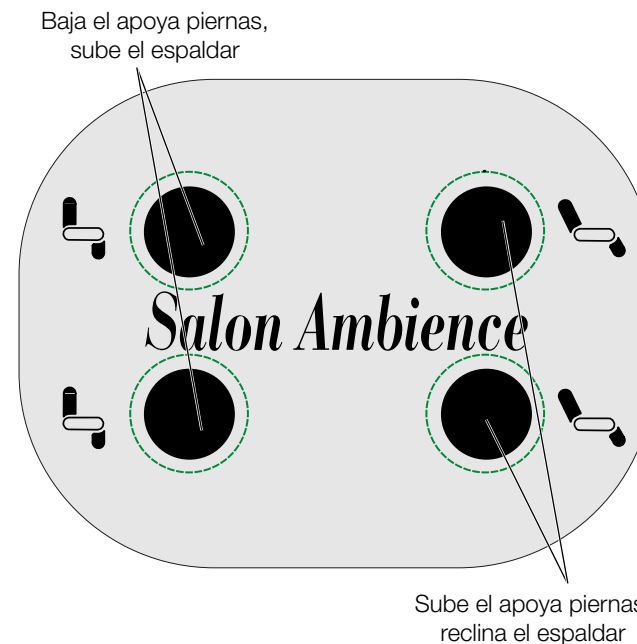

Shiatsu



APENDICE

MANTENIMIENTO GENERAL

Recuerde siempre desconectar el lavacabezas de la red eléctrica durante cualquier reparación, que debe ser realizada por personal calificado.
Verifique periódicamente que no existen pérdidas de agua en la conexión de fontanería, que debe ser realizada por personal calificado.
Comprobar periódicamente el montaje de la cerámica, para garantizar la correcta sujeción para su movimiento.

LIMPIEZA

Para la limpieza de la tapicería usar solo agua y jabón neutro. No usar nunca productos con alcohol para la limpieza del lavacabezas.

CADA SEIS MESES INSPECCIONAR EL SISTEMA DE INSTALACIÓN DE AGUA Y LA PROTECCIÓN DE TELA DEL DESPLAZAMIENTO DEL RODILLO DE MASAJE Y EVENTUALMENTE, SEGÚN LA FRECUENCIA DE USO, LUBRICARLA CON UNA GRASA SINTÉTICA TOPAS NB 52.

ADVERTENCIA

No permita que los niños jueguen con el lavacabezas ni utilicen el mecanismo. El apoya piernas se repliega hacia abajo y puede causar daño a los niños. Dejarlo siempre en posición vertical y cerrado. Mantener siempre las manos y los pies fuera del mecanismo.

Salon Ambience

Mod: **ADVANTAGE⁺**
REVOLUTION⁺/LUXURY

220-240 V 50/60 HZ 100W



Salon Ambience

LUXURY SINGLE WU/015 - WU/016
LUXURY DOUBLE WU/120 - WU/121
WU/122 - WU/123
LUXURY TRIPLE WU/130 - WU/131
WU/132 - WU/133
WU/134 - WU/135
WU/136 - WU/137

Bevat informatie betreffende
installatie en onderhoud van de
Salon Ambience wasstoelen
Luxury

NL

INDEX

HOOFDSTUK 1: INTRODUCTIE

Introductie.....	55
Over uw wasstoel.....	56

HOOFDSTUK 2: INSTALLATIE

Installeer uw wasstoel: water, electriciteit.....	57
---------------------------------------------------	----

HOOFDSTUK 3: INSTRUCTIES

Gebruik van uw wasstoel: Luxury single WU/015.....	60
Luxury double WU/120 - WU/122 - WU/123.....	60
Luxury triple WU/130 - WU/132 - WU/133 - WU/134 - WU/135 - WU/136 - WU/137	60
Gebruik van uw wasstoel: Luxury single WU/016 - Luxury double WU/121.....	61
Luxury triple WU/131 - WU/132 - WU/133 - WU/134 - WU/135 - WU/136 - WU/137	61

APPENDIX

Algemeen onderhoud.....	62
Schoonmaken.....	62
Technische gegevens.....	62
Verklaring van overeenstemming.....	63

INTRODUCTIE

LUXURY SINGLE WU/015 - WU/016
LUXURY DOUBLE WU/120 - WU/121
WU/122 - WU/123
LUXURY TRIPLE WU/130 - WU/131
WU/132 - WU/133
WU/134 - WU/135
WU/136 - WU/137

**Wij danken u hartelijk dat u gekozen hebt voor deze
Salon Ambience wasstoel- een prima keus!**

De prachtige Luxury washunit van Salon Ambience biedt de klant een fantastisch comfort en een bijzondere stijl – een verfijnde, schitterend geproduceerde washunit met een elektrisch verstelbare beensteun, met een gebogen vormgeving, die een speciaal karakter aan de salon geeft, terwijl ook het fantastische comfort dat van een Salon Ambience product verwacht wordt bewaard blijft.

Het Nieuw SHIATSU® massage system is special ontwikkeld om de spieren te ontspannen en druk te verminderen in de lagere rugdelen en tevens de klant het gevoel geeft van ontspanning. Het massage systeem werkt op 4 verschillende drukpunten en heeft een breder werkvlak dan de bestaande Shiatsu systemen.

OVER UW WASSTOEL



Leverbaar in een breed scala van Skai kleuren.

INSTALLATIE AFMETINGEN

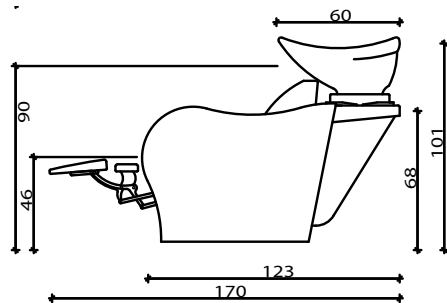

LUXURY SINGLE WU/015 - WU/016

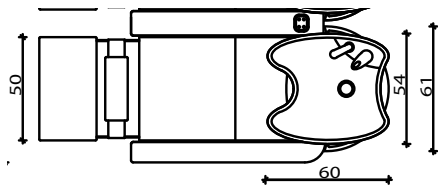

LUXURY DOUBLE WU/120 - WU/121 WU/122 - WU/123

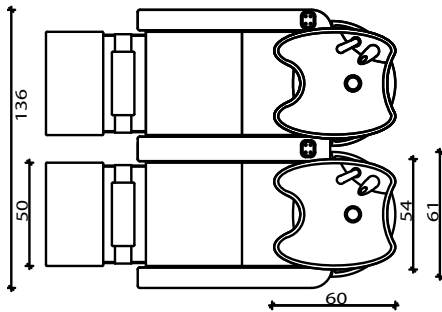

LUXURY TRIPLE WU/130 - WU/131 WU/132 - WU/133 WU/134 - WU/135 WU/136 - WU/137

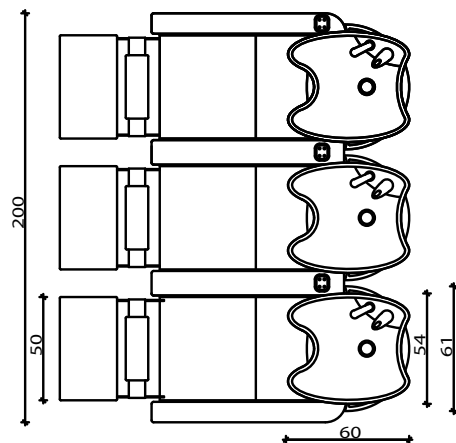

INSTALLATIE

INSTALLLEER UW WASSTOEL; WATER, ELEKTRICITEIT

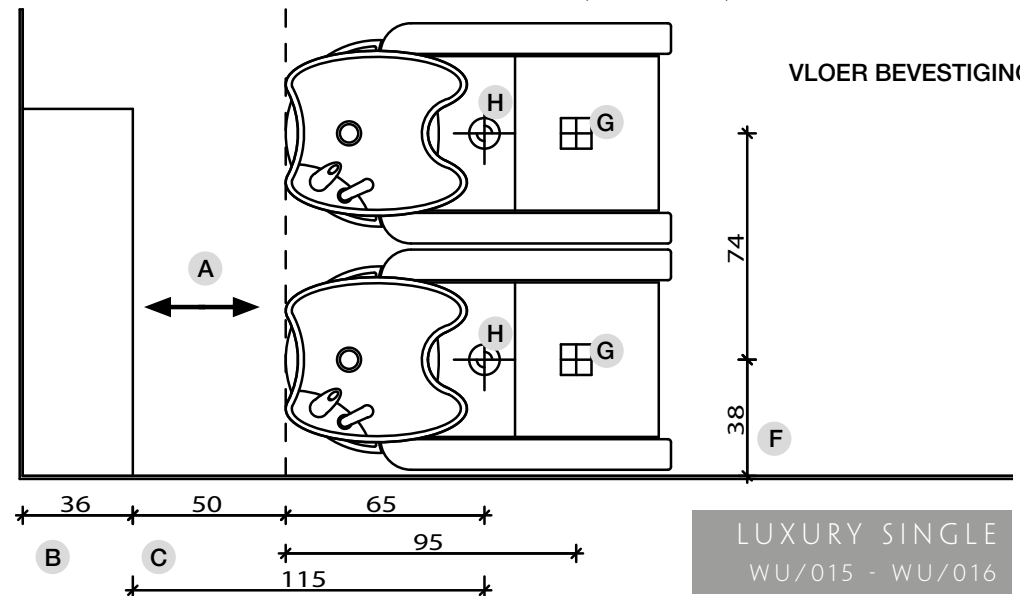

VLOER BEVESTIGING

LUXURY SINGLE
WU/015 - WU/016

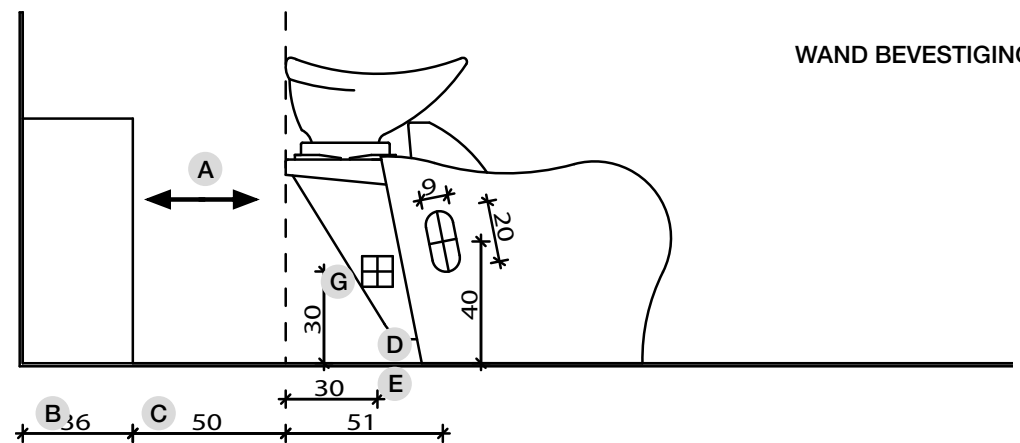

WAND BEVESTIGING

- A** Werkruimte
- B** 36 cm afstand van het muur "Service Centre"
48 cm afstand van het muur "Wall System"
- C** Variabele maat - minimaal 50 cm
- D** Inkomende warm en koud water toevoer
- E** Uitgang water afvoer
- F** Afstand van de muur
- G** Elektrische aansluiting - 220V
- H** Water toevoerpijp 3 / 8 "
Afvoerpijp Ø40

INSTALLATIE

INSTALLEER UW WASSTOEL; WATER, ELEKTRICITEIT

VLOER BEVESTIGING

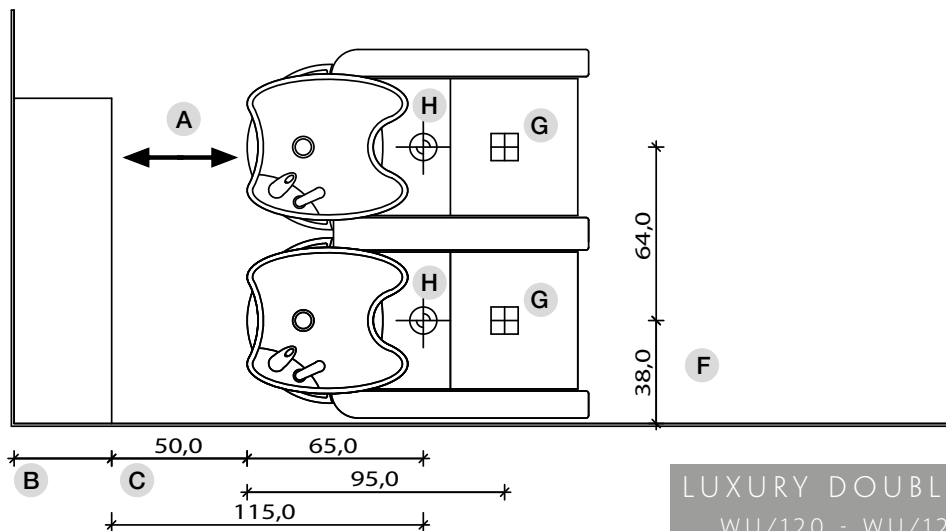

LUXURY DOUBLE
WU/120 - WU/121
WU/122 - WU/123

WAND BEVESTIGING

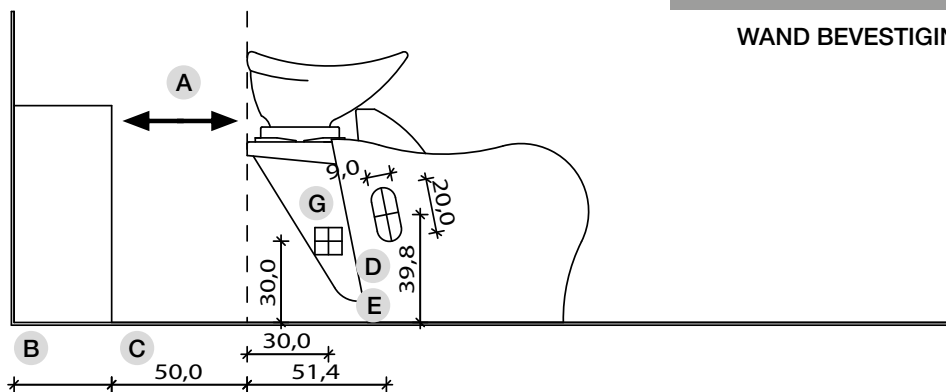

A Werkruimte

B 36 cm afstand van het muur "Service Centre"
48 cm afstand van het muur "Wall System"

C Variabele maat - minimaal 50 cm

D Inkomende warm en koud water toevoer

E Uitgang water afvoer

F Afstand van de muur

G Elektrische aansluiting - 220V

H Water toevoerpijp 3 / 8 "

Afvoerpijp Ø40

INSTALLATIE

INSTALLEER UW WASSTOEL; WATER, ELEKTRICITEIT

VLOER BEVESTIGING

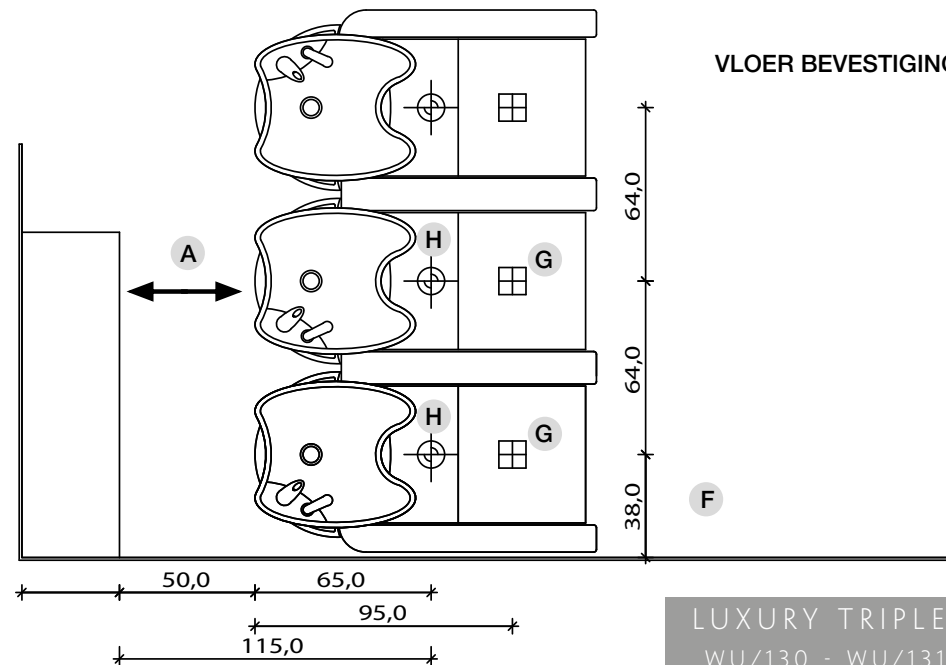

LUXURY TRIPLE
WU/130 - WU/131
WU/132 - WU/133
WU/134 - WU/135
WU/136 - WU/137

WAND BEVESTIGING

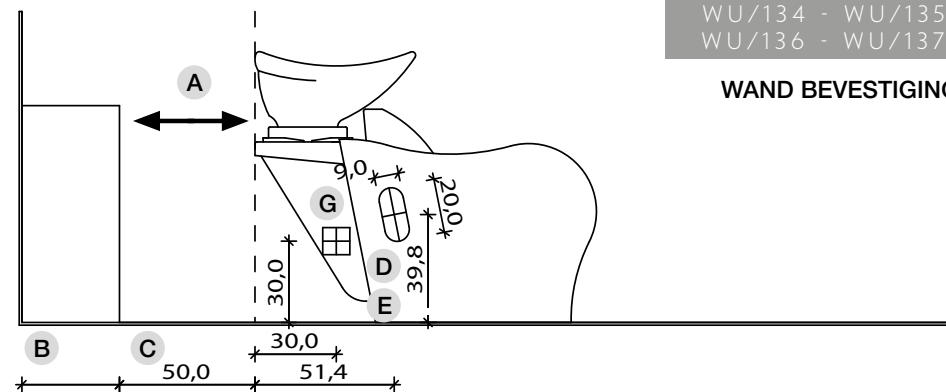

A Werkruimte

B 36 cm afstand van het muur "Service Centre"
48 cm afstand van het muur "Wall System"

C Variabele maat - minimaal 50 cm

F Afstand van de muur

G Elektrische aansluiting - 220V

INSTRUKTIES

LUXURY SINGLE WU/015
 LUXURY DOUBLE WU/120 - WU/122 - WU/123
 LUXURY TRIPLE WU/130
 WU/132 - WU/133 - WU/134 - WU/135 - WU/136 - WU/137

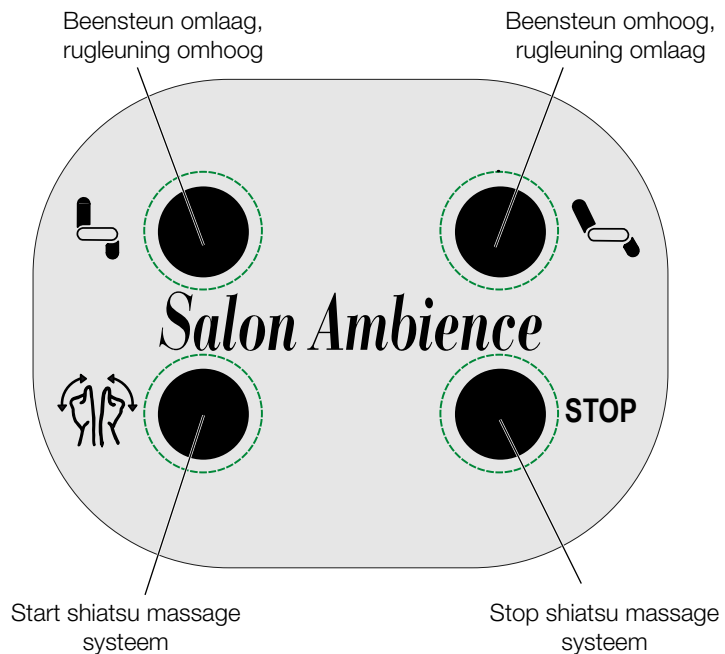

Shiatsu massage



INSTRUKTIES

LUXURY SINGLE WU/016
 LUXURY DOUBLE WU/121
 LUXURY TRIPLE WU/131
 WU/132 - WU/133 - WU/134
 WU/135 - WU/136 - WU/137

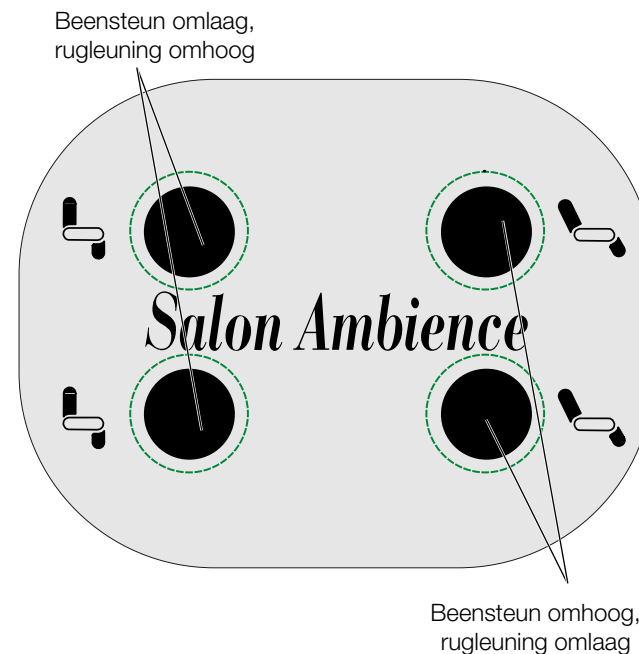

APPENDIX

ALGEMEEN ONDERHOUD

Bij een eventuele reparatie van de wasstoel moet u altijd de stroom uitschakelen, gebruik maken van vakmensen.

Vermijdt dat water op de elektrische verbinding kan komen, laat de verbindingen regelmatig door vakmensen controleren.

Controleer regelmatig de bevestiging van de wasbak om zeker te zijn van goede bevestiging en beweging.

ONDERHOUD

Gebruik alleen water en neutrale zeep bij het schoonmaken van de stoffering.

Gebruik nooit producten op alcohol basis om de washunit schoon te maken.

CONTROLEER ELKE 6 MAANDEN DE WATERAANVOEREN EN AFVOER EN DE RUBBEREN MASSAGE WIELEN EN DE BESCHERMPLAAT TUSSEN DE WIELEN EN DE STOFFERING. AFHANKELIJK VAN HET GEBRUIK MOET U EEN BEETJE VET OP DE WIELEN SMEREN OM DE UNIT GOED TE LATEN WERKEN.

ATTENTIE

Laat kinderen niet spelen op deze beweegbare wasstoel of het mechanisme bedienen. De beensteun gaat naar beneden en kan een kind mogelijk verwonden. Laat de beensteun altijd rechtop staan in de gesloten positie. Houdt de handen vrij van het mechanisme.

Salon Ambience

Mod: **ADVANTAGE⁺**
REVOLUTION⁺/LUXURY

220-240 V 50/60 HZ 100W



Salon Ambience

DICHIARAZIONE DI CONFORMITA'

Noi: Salon Habitat (Italia)
Via Lazzaretti, 12
42122 Reggio Emilia – Italia

Attestiamo che la componentistica elettrica inserita nel nostro

Luxury single WU/015 - WU/016

Luxury double WU/120 - WU/121 - WU/122 - WU/123

Luxury triple WU/130 - WU/131 - WU/132 - WU/133 - WU/134 - WU/135 - WU/136 - WU/137

è conforme alle seguenti disposizioni di legge europee:

- 2004/108/CE e successive modifiche: disposizione di legge del Parlamento Europeo per l'allineamento delle leggi degli stati membri a proposito della tollerabilità elettromagnetica.

Per tale kit sono rispettate le seguenti norme:

EN 55014-1 prove di emc - emissioni

EN 55014-2 prove di emc - immunità

EN 61000-3-2/3 Norme cogenti per il contenimento delle armoniche e delle fluttuazioni

EN 62233 Metodi di misura per campi elettromagnetici degli apparecchi elettrici

di uso domestico e similari con riferimento all'esposizione umana

- 2006/95/CE e successive modifiche: disposizione di legge del Parlamento Europeo per l'allineamento delle leggi degli stati membri a proposito della 'bassa tensione'.

Per tale kit sono rispettate le seguenti norme:

EN 60335-1 Norme di sicurezza sugli apparecchi per uso domestico

EN 60335-2-32 apparecchi per massaggio per uso domestico e similare

Reggio Emilia, 18 marzo 2011

Salon Habitat (Italia)

Il legale rappresentante

Kerry Dade

SALON HABITAT (ITALIA) SRL

Via Lazzaretti 12 - 42122 Reggio Emilia - Tel. 0522 276714 Fax 0522 518355

www.salonambience.com - info@salonambience.com

Registro Imprese di Reggio Emilia n. 01238040354 - REA n. RE 170211

cap. soc.: Euro 70.000,00 i.v.

Salon Ambience

Via Lazzaretti 42122 - Reggio Emilia - Italia

Design Centre

+39 0522 276747

International Sales

+39 0522 276717

Fax

+39 0522 276767

E-mail

info@salonambience.com

Web

www.salonambience.com

Salon Ambience