

SUNLite 24

DANGER Ultraviolet radiation. Follow instructions. Avoid overexposure. As with natural sunlight, overexposure can cause eye and skin injury and allergic reactions. Repeated exposure may cause premature aging of the skin and skin cancer. **WEAR PROTECTIVE EYEWEAR; FAILURE TO MAY RESULT IN SEVERE BURNS OR LONGTERM INJURY TO THE EYES.** Medications or cosmetics may increase your sensitivity to the ultraviolet radiation. Consult physician before using sunlamp if you are using medications or have a history of skin problems or believe yourself especially sensitive to sunlight. If you do not tan in the sun, you are unlikely to tan from the use of this product. Children, the elderly, or fair skinned people who always burn easily and either never tan or tan minimally should not use this equipment.

Contraindication: This product is contraindicated for use on persons under the age of 18 years. **Contraindication:** This product must not be used if skin lesions or open wounds are present.

To use, lie down under canopy and pull down as far as adjustment will allow. Do not use without clear plastic panel and wire grill in place. Untanned persons should not tan on consecutive days during their first week of tanning. Never tan more than once a day. Tanning normally appears after the first few sessions and maximizes after approximately four weeks. Tan once or twice per week thereafter to maintain appearance. Persons already having a base tan may begin at advanced levels corresponding to the extent of their base tan.

Skin Type:

- I Sensitive Skin (Burns easily and severely and does not tan.)
- II Light Skin (Burns easily and severely and tans minimally.)
- III Normal Skin (Burns moderately and tans average.)
- IV Dark Skin (Burns minimally, tans easily and above average.)

RECOMMENDED EXPOSURE TIMES IN MINUTES					
Level 1/Week 1 1st-3rd Sessions	Level 2	Level 3	Level 4	Level 5	
Skin Type:					
I Sensitive	NOT RECOMMENDED FOR TANNING				
II Light	3	6	9	12	15
III Normal	4	7	11	15	15
IV Dark	5	9	13	15	15

MAXIMUM EXPOSURE TIME IS 15 MINUTES

New lamps emit approximately 10% more ultraviolet radiation during the first 50 hours of operation. Recommended tanning times should therefore be reduced by approximately 10% during that period.

WARNING: • Read these instructions before using this sunlamp product. • This product should not be used on individuals who have had skin cancer or have a family history of skin cancer. • Persons repeatedly exposed to UV radiation should be regularly evaluated for skin cancer. • All persons in the room should wear protective eyewear when lamps are on. Recommended eyewear: provided eyeshields or equivalent eyewear as defined under 21 CFR 1040.20. Other types of eyewear may not provide adequate protection. Failure to use protective eyewear may result in severe burns or other eye injury. If discomfort develops, discontinue use and consult a physician.

THE FOLLOWING LAMPS HAVE BEEN CERTIFIED FOR USE IN THIS EQUIPMENT:

SunFire® Model SF71-T12-100W/P Bi-Pin

SunFire® POWER WINDOW® Model SFPW71-T12-100W/P Bi-Pin

Disconnect power cord before attempting to clean, relamp, or engage in the maintenance of this product

THIS EQUIPMENT MUST BE EARTH GROUNDED.

This product is in conformity with performance standards for sun lamp products under 21 CFR PART 1040.20 and ANSI/UL Standard 482.

Electrical Requirements

Your sunbed operates from a **120V AC** source. You should have a **NEMA 5-20R** electrical outlet (below), on a dedicated circuit capable of providing **20 Amp service**, installed in the room in which you will use the unit. We recommend installation by a professional electrician. The outlet must be earth grounded.

20 AMP NEMA #5-20R RECEPTACLE 



⚠ DANGER

Shock hazard.

Disconnect power before servicing or removing any protective covers.

Do not operate this device near water or while you are wet.

⚠ DANGER

Some medications may increase your sensitivity to ultraviolet light. It is recommended that you consult a physician before using this sunbed if taking any medication or if you suspect that your skin might be especially sensitive to sunlight.

⚠ WARNING

Wear protective eyewear.

Failure to may result in severe burns or longterm injury to the eyes.

⚠ CAUTION

Air from the room is used to cool the sunbed. Maximum ambient room temperature should be 80°F. Place your sunbed no closer than 6" from any wall. Make sure nothing obstructs the airflow into the sunbed's endcaps or out of the fan openings. A poorly ventilated room may cause the unit to become hot and cause discomfort to the user.

Unpacking and Inspection

Your sunbed comes in two cardboard cartons. Pull back the plastic sheet and, with a helper, grasp the bench and pull it from the carton bottom, leaving the plastic wrap and the carton packaging. Do not try to lift the unit with the plastic still on as it may slip. Do the same with the canopy.

The canopy box contains the canopy, a pair of gas springs, and the assembly hardware. The bench box contains the bench and stand legs.

Inspect the items and make sure they are free from any visible damage. Report the extent of any damage to the transportation company.

Hardware Inventory (Plus a small pillow and eyewear)

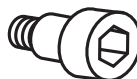

Shoulder Bolt
Quantity 2



Hex (Allen) Wrench
Quantity 1



Flanged Sleeve Bushing
Quantity 2



Nylon Flat Washer
Quantity 2



3/8" Washer, Black
Quantity 2



3/8-16 Locknut, Black
Quantity 2

You Will Need:



#2 Phillips Screwdriver



9/16" Wrench

Assembly Procedures

1 Lay the bench upside down on the floor. Locate the two stand legs.

2 Remove the six bolts and washers installed in the bench.

3 Use the same bolts and washers to attach the stand legs. Make sure the bolts are secure.

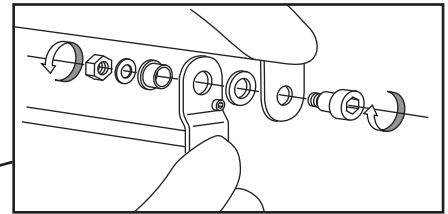
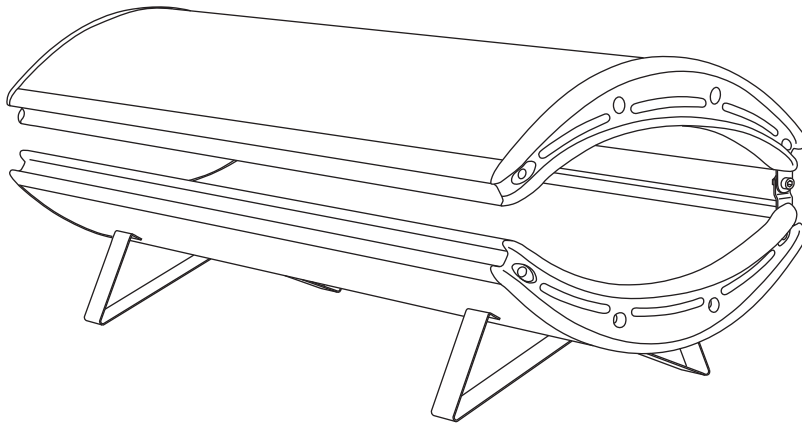
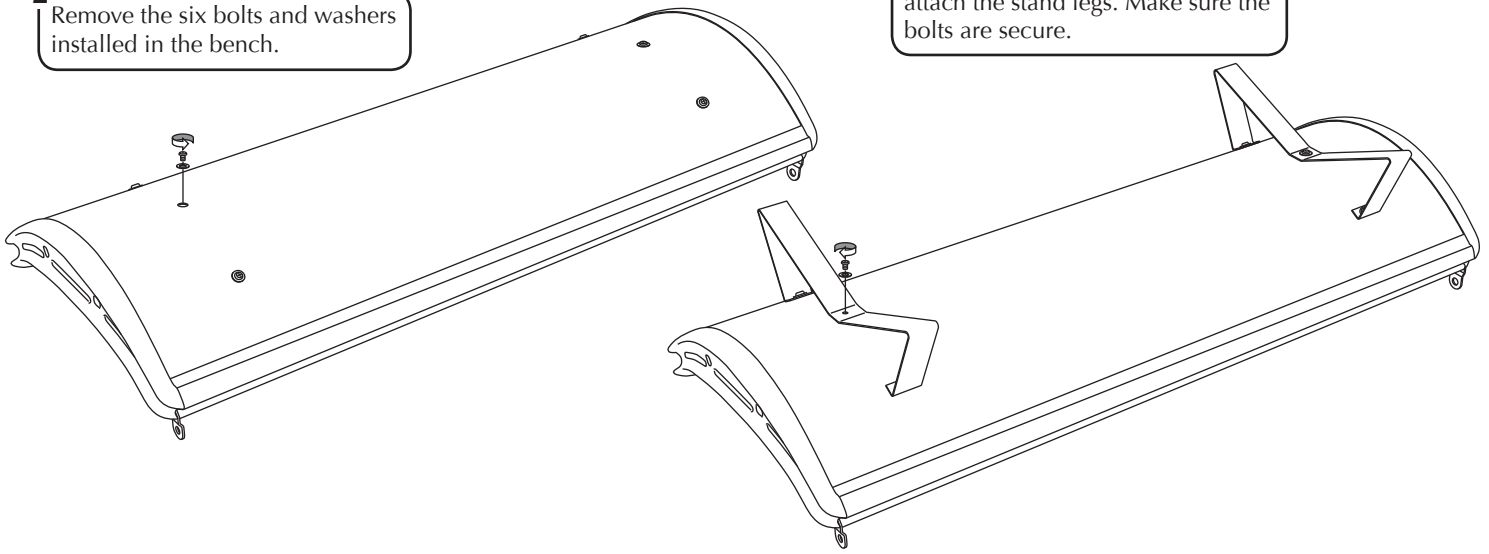

4 Turn the bench over and attach the canopy as shown. Be sure the white Nylon Washer is between the hinges.

5 With a helper holding the canopy open, align ends of gas spring ball joints with pivot studs and push into place. Be sure rod end is down as shown. DO NOT lower canopy until both gas springs are secure!

6 Lift and lower canopy a few times to lubricate gas springs for optimum performance.

7 Connect the canopy to bench power cords. Make sure the connection is secure.

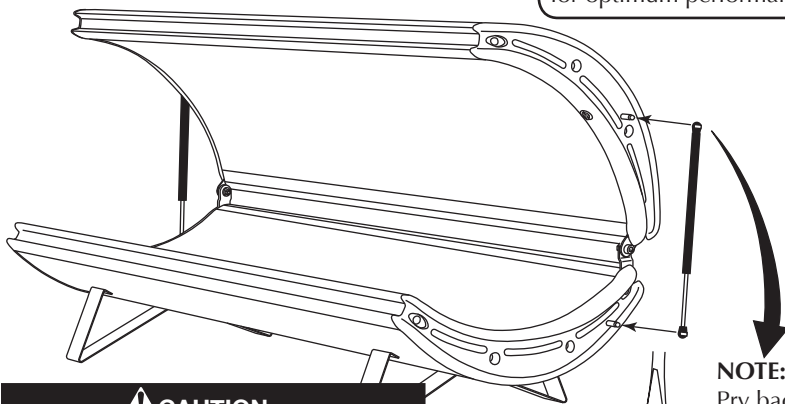

NOTE:
Pry back the metal locking clip with a flat screwdriver to make installation easier.

8 Plug the three-prong 120V AC power cord into a dedicated outlet (see *Electrical Requirements*).

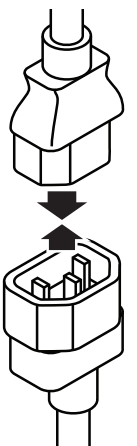

CAUTION

Failure to engage locking clips may result in the ball joints working loose, allowing the canopy to fall, which may result in damage to the unit and injury.

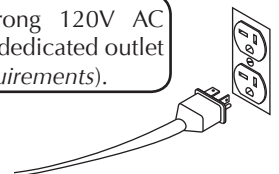

Using Your Sunbed

Before using your sunbed, please note the following:

- Your skin should be free of cosmetics, tanning oils, or other body lotions prior to tanning except for those specifically made for use with tanning devices. However, do not remove natural body oils by bathing or showering immediately before tanning.
- Keep treated hair from contacting sunbed surfaces. Many hair products can damage the sunbed acrylic. Wear a shower cap or towel if you use gels, mousses, sprays, or other hair products.
- Your sunbed is designed for individual use. Always wear the safety goggles supplied with your sunbed or another approved pair of goggles, as defined under 21 CFR 1040.20. Regular sunglasses do not provide adequate protection from ultraviolet light.

Follow the guidelines for skin type and exposure times as shown in the table below. Untanned persons should not tan on consecutive days during their first week of tanning. Never tan more than once a day. Tanning normally appears after the first few sessions and maximizes after approximately four weeks. Tan once or twice per week thereafter to maintain appearance. Persons already having a base tan may begin at advanced levels corresponding to the extent of their base tan.

Skin Type:

- I Sensitive Skin (Burns easily and severely and does not tan.)
- II Light Skin (Burns easily and severely and tans minimally.)
- III Normal Skin (Burns moderately and tans average.)
- IV Dark Skin (Burns minimally, tans easily and above average.)

RECOMMENDED EXPOSURE TIMES IN MINUTES					
Skin Type:	Level 1/Week 1 1st-3rd Sessions	Level 2	Level 3	Level 4	Level 5
I Sensitive	NOT RECOMMENDED FOR TANNING				
II Light	3	6	9	12	15
III Normal	4	7	11	15	15
IV Dark	5	9	13	15	15

MAXIMUM EXPOSURE TIME IS 15 MINUTES

Operation

- 1 Lift the canopy, lie down on the bench (face up), lower the canopy as close to your body as possible.
- 2 Turn the timer knob clockwise to the desired tanning session time to begin the tanning session. The lamps will turn on immediately.
- 3 When the timer reaches "0" the lamps turn off. If you want to stop your session before time expires, turn the timer knob back to "0".
- 4 Raise the canopy by pushing the outer edge of the canopy.

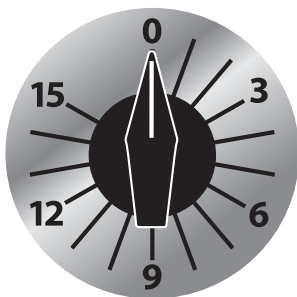

Care and Maintenance

Cleaning After Use

Clean and disinfect your tanning bed's bench and canopy after each use. Use a non-abrasive disinfectant cleaner (such as a mixture of 2oz of Lucasol™ disinfectant with 1 gallon of water) that does not contain ammonia or ammonia derivatives which may damage the acrylic surface. Spray the acrylic with disinfectant until thoroughly wet. Allow to remain wet for 10 minutes and then let air dry. Wipe the canopy grill with a soft cloth slightly dampened with disinfectant, then let air dry.

For heavily soiled areas remove the soil (lotions, etc.) using Lucas® Spray and Wipe Tanning Bed Acrylic Cleaner. Apply solution with spray bottle to wet the area thoroughly. Allow to remain wet for 30 seconds and then wipe the surface dry. Then disinfect as described above.

Thorough Periodic Cleaning

The cooling fans draw air through the bed and will cause a dust build-up on the lamps and reflectors. When a dust buildup is observed, it is necessary to thoroughly clean the inside of the bench and canopy.

- 1 Remove the acrylic shield, metal grill and lamps.
- 2 With a soft cloth, wipe the entire length of each lamp.
- 3 Clean both sides of the acrylic shield and grill with a non-ammonia disinfectant cleaner.
- 4 Wipe the reflectors with a clean damp cloth.
- 5 Re-install the lamps, acrylic shield and grill.

Mechanical Inspection

Inspect the unit's mechanical integrity every 400-500 hours of use.

- Inspect the unit's fasteners verifying that all are firmly in place. Pay particular attention to the hinge bolts.
- Inspect gas springs for signs of wear. Replace gas springs that will not hold the canopy in the full open position when raised.
- Inspect the AC power cord and its connections.
- Inspect the acrylic. Replace if broken, cracked or badly scratched.

Removing/Replacing Acrylic Shield (bench)

The acrylic shield in the bench and metal grill in the canopy are secured in place by hinged profiles which run the length of the bed, both front and back. Start at the end and simply ① push the inside edge of the profile toward the aluminum bed frame until it releases its latching action and then ② lift. Continue to lift the profile across its entire length until it swings back freely. Repeat for the other profile. The long edges of the acrylic shield are now exposed. Standing in front of the sunbed, grasp the edge of the acrylic and carefully lift it out of the bench.

Replace the bench acrylic by laying it on the bench and pressing into place. Close the hinged profile by pushing it back into place until it snaps tight.

Removing/Replacing Canopy Grill

Follow the above directions for opening the hinged profiles. As you pry the hinged profile open the canopy grill should start to drop out on its own.

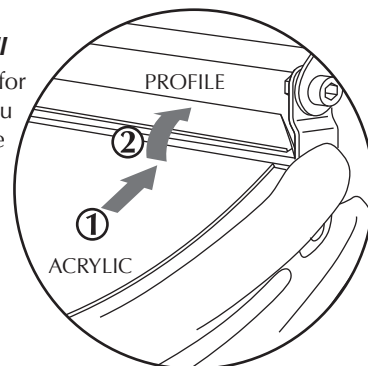

To be assured of maximum tanning effectiveness, change lamps after approximately 500 hours of use. Tanning will continue after this time but at a slower rate. We recommend using the lamps specified below. Use of uncertified lamps is a violation of Federal regulations and may void your warranty.

- 1 Grasp a lamp at one end and at the middle, then turn the lamp a quarter turn. The lamp may then be gently removed from its holder.
- 2 To reinstall lamp, insert pins on the ends of the lamp into the slots on top of the lamp holder and turn the lamp a quarter turn.

The following lamps have been certified for use in this equipment:

SunFire® POWER WINDOW® Model SFPW71-T12-100W/P Bi-Pin
SunFire® Model SF71-T12-100W/P Bi-Pin

Problem	Solution	Troubleshooting
Sunbed not tanning	<ol style="list-style-type: none"> Clean sunbed, see Thorough Periodic Cleaning. Replace lamps if lamp hours are greater than 800hrs. Replace acrylic. 	
Lamps fail to light	<ol style="list-style-type: none"> Check source of AC power. Reset circuit breaker or replace fuse if necessary. Make sure the unit is plugged into outlet. Make sure canopy to bench cord is properly connected. 	
One or more lamps fail to light	<ol style="list-style-type: none"> Check that lamp is installed correctly. Switch unlit lamp with a lamp that lights. If the new lamp lights and the old lamp still does not, replace old lamp. 	

Problem	Solution	Troubleshooting
The canopy will not stay up	<p>NOTE: Gas springs are manufactured to hold the canopy in its fully open position as well as allow it to rest fully closed. If left open for an extended period of time some creep down may occur. This is considered normal. Keep the unit closed when not in use. If the canopy will not stay fully open when raised...</p> <ol style="list-style-type: none"> Raise and lower the canopy a few times to lubricate gas spring internal seals. Replace gas springs. Tighten the hinge bolts to create friction. 	
Sunbed does not stay lit	Check source of AC power. Reset circuit breaker or replace fuse if necessary.	

1. Warranty Period: SUNFIRE INDUSTRIES warrants new tanning equipment manufactured by it, provided it is still owned and operated by the original purchaser, to be free from defects in material and workmanship under normal use and service, for a prorated period of twelve (12) months from the date of delivery to the original Purchaser.

2. What is covered: During the warranty period as specified above SUNFIRE INDUSTRIES will replace any defective system or component, at SUNFIRE INDUSTRIES's sole discretion. The Purchaser shall be responsible for the difference between the cost of a new system or component and the prorated value of the defective system or component. Prior to making any repairs SUNFIRE INDUSTRIES will advise the Purchaser of the nature of the problem and the cost to the Purchaser based on the prorated of the defective system or component.

3. What is not covered:

- A. Acrylic sheets, starters (igniters), lamps, blue and clear filter glass.
- B. Any plastic parts affected by discoloration.
- C. Cracked or broken cover plates, end caps and sidebars
- D. Any failure to the external timing system (example: T-Max, FST timers and timer system components)
- E. Any failure to the external voltage transformer (example: "buck and boost" transformers)
- F. Any damage caused by the failure of any supporting hardware not supplied by SUNFIRE INDUSTRIES.
- G. Any labor charges, travel time charges, or mileage charges associated with a warranty item.
- H. Shipping costs back to SUNFIRE INDUSTRIES'S factory. SUNFIRE INDUSTRIES will pay for ground transportation of repaired or replaced part back to purchaser.
- I. Tanning units, parts or components damaged in transit where SUNFIRE INDUSTRIES'S damaged goods policy is not followed by purchaser or purchaser's designee.

This warranty does not apply to any failure of product due to alterations, modifications, misuse, abuse, neglect, accident, improper maintenance or installation, use of parts not supplied by SUNFIRE INDUSTRIES, failure to operate and use the product in accordance with the instructions provided in the Owner's Manual supplied with the product or failure to otherwise meet manufacturer's specifications, or if the serial number has been removed, altered or defaced.

6. Procedure for Requesting Warranty Work: In the event of a problem covered under this limited warranty, the customer must first contact SUNFIRE INDUSTRIES and obtain a Returned Goods Authorization for products to be repaired or replaced at SUNFIRE INDUSTRIES's discretion, provided product(s) are returned freight prepaid to SUNFIRE INDUSTRIES. SUNFIRE INDUSTRIES will perform its obligation within thirty (30) days from the date of SUNFIRE INDUSTRIES's receipt of the Purchaser's authorization to effect repairs and acceptance of the cost of repairs based on the prorated values of the defective systems or components. Any payment due from the Purchaser shall be payable in full prior to SUNFIRE INDUSTRIES's return of the repaired system or component. Any product being returned to SUNFIRE INDUSTRIES for repair or replacement must be adequately packaged to prevent freight damage and shipped via traceable method

7. Right to Modify: SUNFIRE INDUSTRIES reserves the right to make changes or improvements in its products without incurring any obligations to similarly alter products which have been previously purchased.

8. Exclusivity of Warranty: This warranty is the only warranty made by SUNFIRE INDUSTRIES and may only be modified or amended by a written instrument signed by a duly authorized officer of SUNFIRE INDUSTRIES. SUNFIRE INDUSTRIES's sole and exclusive liability and Purchaser's sole and exclusive remedy under this warranty shall be, at SUNFIRE INDUSTRIES's option, to repair or replace, to the extent available on a prorated basis, any such defective Products. These remedies are available only if SUNFIRE INDUSTRIES's examination of such Products discloses to SUNFIRE INDUSTRIES's satisfaction that such defects actually exist and were not caused by Purchaser's misuse, abuse, neglect, improper installation, maintenance or testing, alterations or modifications, failure to meet manufacturer's specifications or any other cause beyond the range of normal usage, or by accident, fire or other hazard. Repair or replacement of a part does not extend the warranty period or extend the prorated value of a part or product beyond the initial two year limited warranty period from the date of delivery.

THE WARRANTY SET FORTH ABOVE IS IN LIEU OF ALL OTHER WARRANTIES, EXPRESS OR IMPLIED, INCLUDING BUT NOT LIMITED TO ANY IMPLIED WARRANTY OF MERCHANTABILITY OR FITNESS FOR A PARTICULAR PURPOSE. IN NO EVENT SHALL SUNFIRE INDUSTRIES BE LIABLE FOR ANY INCIDENTAL OR CONSEQUENTIAL DAMAGES WITH RESPECT TO THE PRODUCTS DELIVERED HEREUNDER OR SUBSEQUENT USE THEREOF.

9. Limitation of Liability: SUNFIRE INDUSTRIES shall not be liable for any loss, damages, or penalty resulting from failure to perform any of its obligations under this Agreement due to force majeure or any cause beyond its reasonable control.

SUNFIRE INDUSTRIES'S LIABILITY UNDER OR FOR BREACH OF THIS AGREEMENT SHALL NOT EXCEED THE REFUND OF THE PURCHASE PRICE LESS REASONABLE RENTAL FOR PAST USE. IN NO EVENT SHALL SUNFIRE INDUSTRIES BE LIABLE FOR COSTS OF PROCUREMENT OF SUBSTITUTE GOODS BY THE PURCHASER OR FOR UNAUTHORIZED REPAIRS UNDERTAKEN BY THE PURCHASER WITHOUT SUNFIRE INDUSTRIES'S PREVIOUS WRITTEN APPROVAL. IN NO EVENT SHALL SUNFIRE INDUSTRIES BE LIABLE FOR ANY SPECIAL, CONSEQUENTIAL, OR INCIDENTAL DAMAGES, HOWEVER CAUSED, WHETHER FOR BREACH OF WARRANTY, NEGLIGENCE, OR OTHERWISE. SUNFIRE INDUSTRIES DISCLAIMS ANY OBLIGATION OR LIABILITY FOR LOSS OF USE OF THE PRODUCT WARRANTED, LOSS OF TIME, INCONVENIENCE, RENTAL OR SUBSTITUTE PRODUCTS, LOSS OF BUSINESS, LOSS OF INCOME, COMMERCIAL LOSS OR ANY OTHER DIRECT, CONSEQUENTIAL, SPECIAL OR INCIDENTAL DAMAGES.

10. Governing Law: Notwithstanding principles of conflicts of law of any jurisdiction to the contrary, all terms and provisions of this Agreement are to be construed and governed by the laws of the state of North Carolina without regard to the laws of any other jurisdiction. The Purchaser waives any and all privileges and rights which they may have under North Carolina Statutes, relating to venue as it now exists or may hereafter be amended, and under any other statute, or administrative provision thereof in any legal action on this Agreement; and further, the Purchaser agrees that any legal action brought on this Agreement or in connection therewith, shall be brought in the appropriate court in Craven County, North Carolina.

11. Attorney's Fees: Should a dispute arise with regard to this warranty or any other aspect of this sale the prevailing party shall be entitled to reasonable attorneys fees and costs through appeal.

To obtain warranty service visit www.SunFireTanningBeds.com.

Date of purchase: _____

Bench serial number: _____

Canopy serial number: _____

Proudly manufactured in the U.S.A.