

Wet. wipes

ANTIBACTERIAL WIPES DISPENSER

Premium protection and care for your workplace

In shared facilities, it's important to reduce cross-contamination and protect your staff and customers from the risks of poor surface hygiene.

It's easy to keep surfaces looking clean – but more important to keep them hygienic. Our handy WetWipe dispenser helps you do both.

- Stylish wallmounted design
- 200 wipes
- Hygiene in an instant - break the infection chain!



Why choose our Antibacterial WetWipes?



ELIMINATES HARMFUL VIRUSES & BACTERIA

E. Coli, Salmonella, Listeria,
Staphylococcus etc.



HYGIENICALLY SUPERIOR

Disposable wipes that
clean and sanitise



EASY TO USE

Individual pre-moistened wipes
– easy dispensing solution



NZ MADE WIPES & DISPENSER

Support local industry



LABORATORY TESTED AND VALIDATED

MPI approved C 44
AsureQuality approved



Ideal for cleaning and sanitising work surfaces and equipment

- Antibacterial wipes eliminate harmful viruses and bacteria on any hard surface
- Easy dispensing - perforated pre-moistened wipes
- 200 wipes per refill - sheet size 140mm W x 200 mm L
- New Zealand MPI C44 approved
- New Zealand AsureQuality approved (for food, beverage, dairy, contact surfaces ref H1449)

Product range



WetWipes Dispenser
SKU# 30001
White



Antibacterial WetWipes
SKU# 33100
200 Wipes/Refill
20 Refills/Carton

Specifications

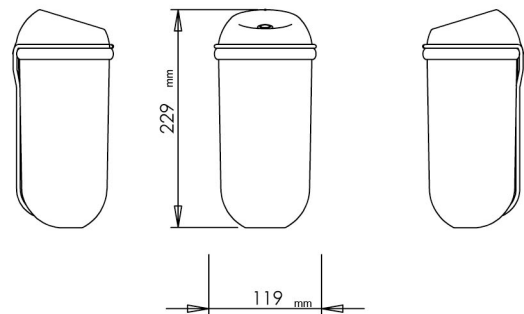

Distributor:

For more information

email: sales@starhygiene.com.au

Ph: 1800 HYGIENE

