



AMETEK
LAMB ELECTRIC



Product Bulletin

Model: 119916-12

DESCRIPTION

- Two stage
- 120 volts
- **3.5" High Efficiency Lamination**
- 7.2"/183 mm diameter
- Double ball bearings
- **Self Cleaning Fan System**
- Tangential bypass discharge
- Aluminum fan end bracket
- Aluminum commutator bracket

DESIGN APPLICATION

- Equipment operating in environments requiring separation of working air from motor ventilating air
- Designed to handle clean, dry, filtered air only

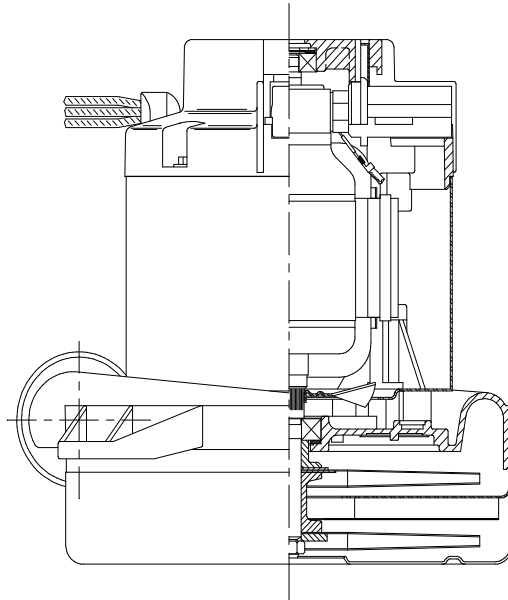

SPECIAL FEATURES

- **600+ Peak Air Watts**
- High Efficiency Lamination
- 10 mm shaft and bearing system
- **Self Cleaning Fan System**
- Epoxy painted fan case
- Aluminum brackets to dampen vibration & improve durability
- Suitable for 120 volt AC operation, 50/60 Hz
- UL recognized, category PRGY2 (E47185)
- CSA certified, class 1611 01 (LR31393)

PEAK AIRWATTS
610
Calculated in accordance with ASTM F2105

TYPICAL MOTOR PERFORMANCE.*

(At 120 volts, 60Hz, test data is corrected to standard conditions of 29.92 Hg, 68° F.)

ASTM DATA

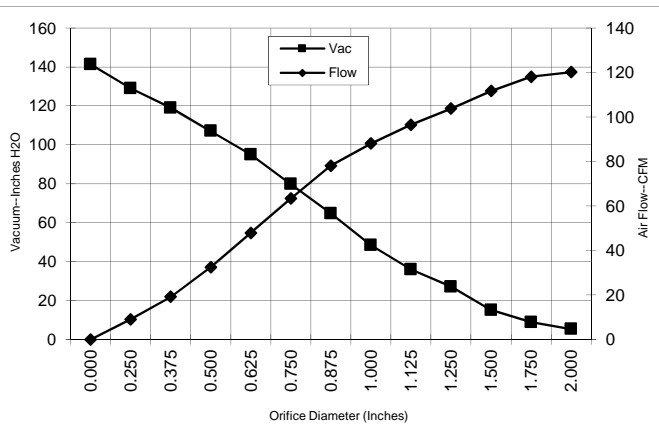

Orifice (Inches)	Amps	Watts (In)	RPM	Vac (In.H ₂ O)	Flow (CFM)	Air Watts
2.000	15.8	1785	21020	5.4	120.2	76
1.750	15.8	1782	21040	8.9	118.1	124
1.500	15.8	1787	21020	15.1	111.7	198
1.250	15.0	1783	21050	27.1	103.8	331
1.125	15.7	1776	21140	36.0	96.5	409
1.000	15.6	1765	21220	48.4	88.1	502
0.875	15.3	1735	21290	64.8	78.1	595
0.750	14.7	1666	21730	79.8	63.4	594
0.625	13.7	1564	22360	95.0	47.9	535
0.500	12.5	1432	23320	107.1	32.5	410
0.375	11.1	1279	24570	119.0	19.2	269
0.250	9.9	1145	25940	129.1	9.1	138
0.000	9.0	1043	27250	141.4	0.0	0

METRIC DATA

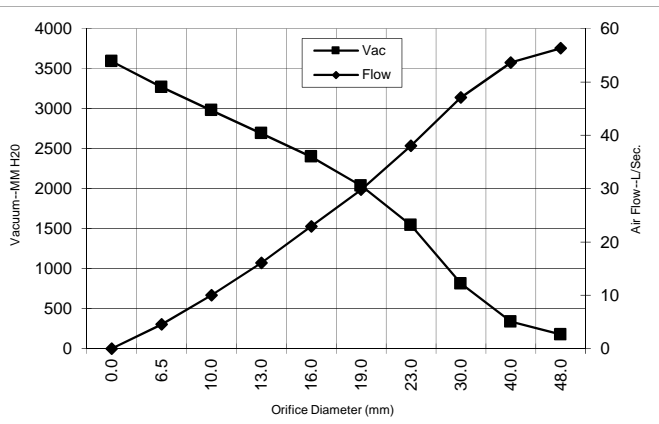

Orifice (mm)	Amps	Watts (In)	RPM	Vac (mm H ₂ O)	Flow (L/Sec)	Air Watts
48.0	15.8	1784	21029	176	56.3	97
40.0	15.8	1786	21026	336	53.6	176
30.0	15.4	1779	21100	813	47.1	374
23.0	15.4	1743	21273	1542	38.0	572
19.0	14.7	1664	21743	2035	29.8	593
16.0	13.8	1568	22335	2398	22.9	538
13.0	12.6	1445	23224	2690	16.1	422
10.0	11.3	1302	24383	2977	10.0	290
6.5	10.0	1152	25872	3266	4.5	145
0.0	9.0	1043	27250	3592	0.0	0

Note: Metric Performance data is calculated from the ASTM data above.

* Data represents performance of a typical motor sampled from a large production quantity. Individual motor data may vary due to normal manufacturing variations.

Test Specs: 120 volts	Minimum Sealed Vacuum: 128"	ORIFICE: 7/8"	Minimum Vacuum: 61"	Maximum Watts: 1860
------------------------------	------------------------------------	----------------------	----------------------------	----------------------------

DIMENSIONS

NOTES:

1. LEADS: 16GA. STRANDED, ONE BLACK AND ONE WHITE. GROUND LEAD: 18GA. STRANDED, GREEN WITH YELLOW STRIPE.

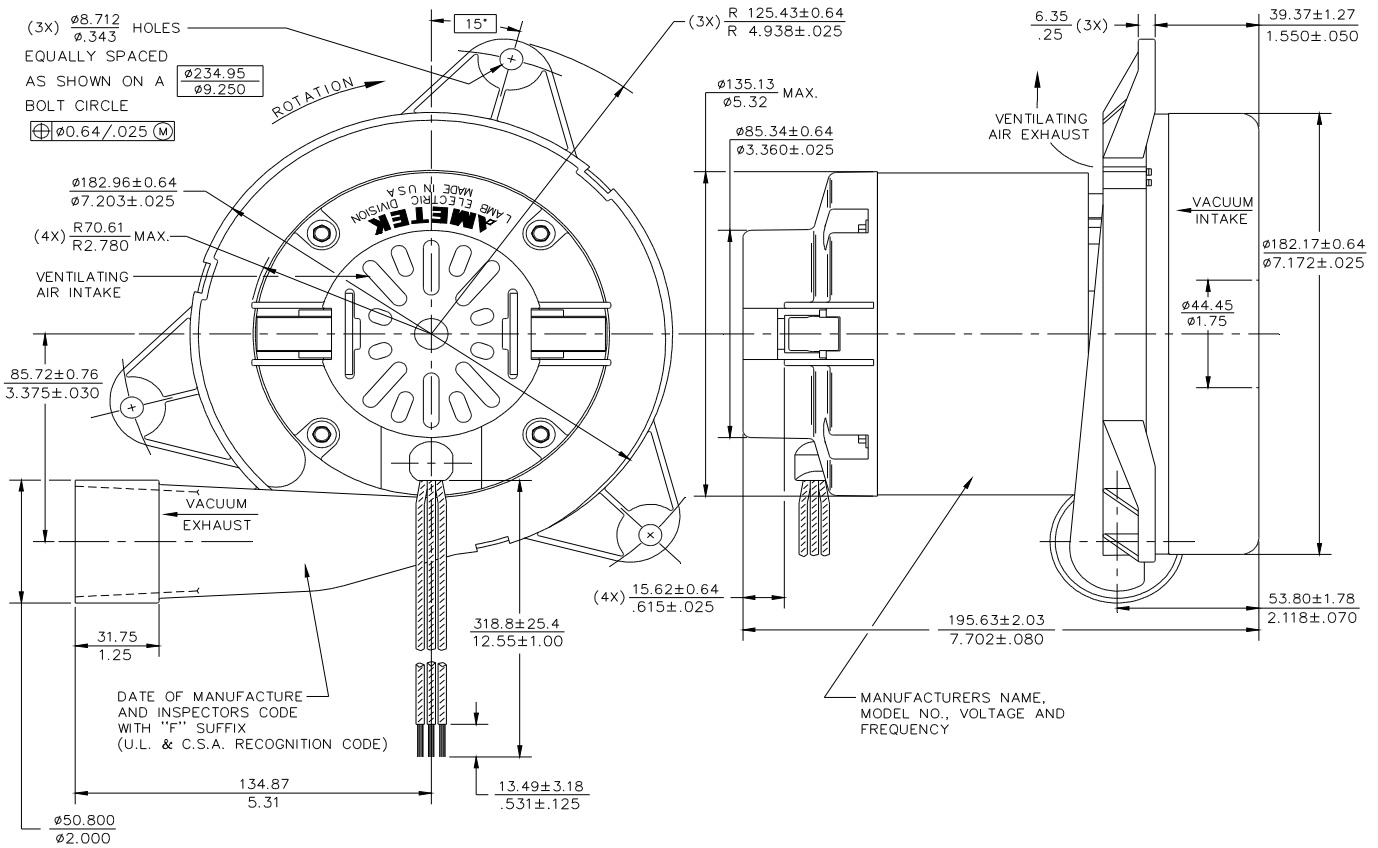

IMPORTANT NOTE: Pictorial and dimensional data are subject to change without notice. Contact factory for current revision levels.

WARNING - When using AMETEK Lamb Electric bypass motors in machines that come in contact with foam, liquid (including water), or other foreign substances, the machine must be designed and constructed to prevent those substances from reaching the fan system, motor housing, and electrical components. Lamb Electric vacuum motors other than hazardous duty models should not be applied in machines that come in contact with dry chemicals or other volatile materials. Failure to observe these precautions could cause flashing (depending on volatility) or electrical shock which could result in property damage and severe bodily injury, including death in extreme cases. All applications incorporating Lamb Electric motors should be submitted to appropriate organizations or agencies for testing specifically related to the safety of your equipment.

AMETEK/Floorcare & Specialty Motors
www.ametekfsm.com