

AMETEK
LAMB ELECTRIC

Product Bulletin

Models: 115923

DESCRIPTION

- Two stage
- 120 volts
- 5.7"/145 mm diameter
- Double ball bearings
- Single speed
- Thru-flow discharge
- Aluminum fan end bracket
- Aluminum commutator bracket

DESIGN APPLICATION

- Equipment operating in environments not requiring separation of working air from motor ventilating air
- Designed to handle clean, dry, filtered air only

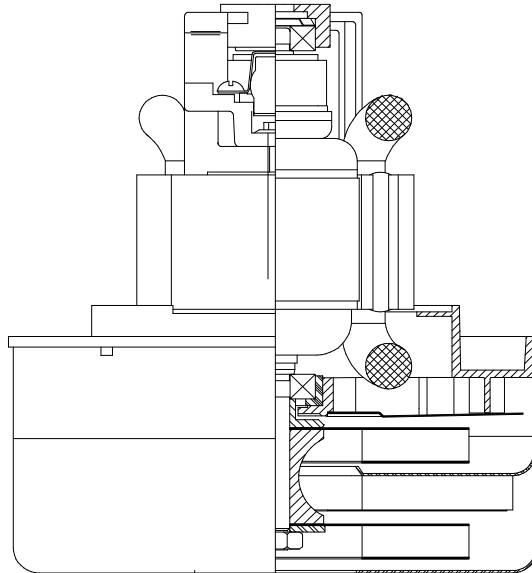

SPECIAL FEATURES

- Suitable for 120 volt AC operation, 60 Hz
- UL recognized, category PRGY2 (E47185)
- CSA certified, class 1611 01 (LR31393)
- Provision for grounding
- Skeleton-frame construction
- High air flow fan system
- The Lamb Electric vacuum motor line offers a wide range of performance levels to meet design needs

TYPICAL MOTOR PERFORMANCE.*

(At 120 volts, 60Hz, test data is corrected to standard conditions of 29.92 Hg, 68° F.)

ASTM DATA

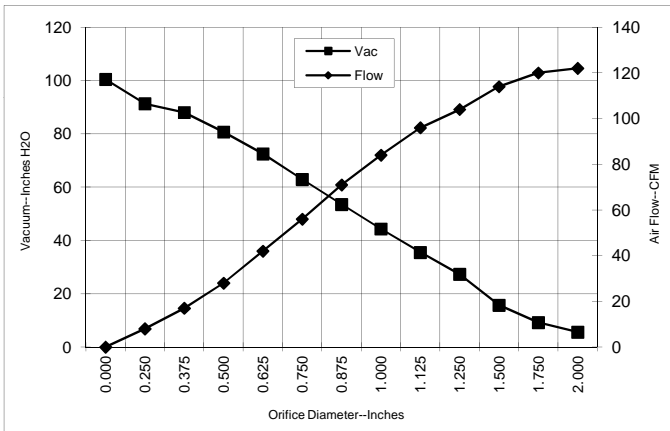

Orifice (Inches)	Amps	Watts (In)	RPM	Vac (In.H2O)	Flow (CFM)	Air Watts
2.000	10.6	1164	22510	5.6	122.0	80
1.750	10.7	1171	22510	9.2	120.0	131
1.500	10.8	1170	22470	15.7	114.0	210
1.250	10.7	1171	22380	27.3	104.0	335
1.125	10.7	1169	22510	35.5	96.0	401
1.000	10.5	1160	22720	44.3	84.0	439
0.875	10.2	1146	23070	53.5	71.0	447
0.750	9.7	1117	23700	62.9	56.0	417
0.625	9.0	1061	24520	72.5	42.0	357
0.500	8.4	983	25460	80.7	28.0	267
0.375	7.7	908	26450	88.0	17.0	172
0.250	6.9	818	26880	91.3	8.0	84
0.000	6.6	785	28400	100.4	0.0	0

METRIC DATA

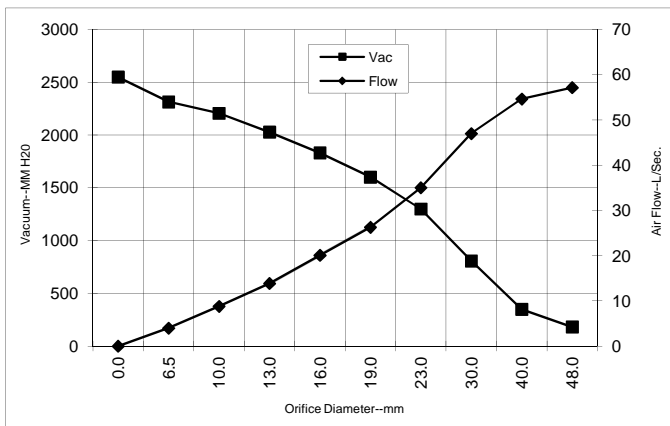

Orifice (mm)	Amps	Watts (In)	RPM	Vac (mm H2O)	Flow (L/Sec)	Air Watts
48.0	10.6	1167	22510	182	57.2	102
40.0	10.8	1170	22482	349	54.7	186
30.0	10.7	1170	22452	808	47.0	371
23.0	10.3	1150	22983	1300	35.0	445
19.0	9.7	1116	23716	1603	26.3	416
16.0	9.0	1063	24487	1832	20.1	359
13.0	8.5	991	25366	2029	13.9	276
10.0	7.8	919	26302	2207	8.8	186
6.5	6.9	823	26859	2315	4.0	88
0.0	6.6	785	28400	2550	0.0	0

Note: Metric Performance data is calculated from the ASTM data above.

* Data represents performance of a typical motor sampled from a large production quantity. Individual motor data may vary due to normal manufacturing variations.

Test Specs:	120 volts	Minimum Sealed Vacuum:	89"	ORIFICE:	7/8 "	Minimum Vacuum:	42"	Maximum Watts:	1320
-------------	-----------	------------------------	-----	----------	-------	-----------------	-----	----------------	------

DIMENSIONS

NOTES:

1. LEADS: 18GA STRANDED.
2. GROUNDING OR EARTHING PROVISIONS: USE HOLES AS INDICATED FOR GROUNDING OR EARTHING. REFER TO APPROPRIATE LISTING OR REGULATORY AGENCY FOR PROPER METHOD OF GROUNDING OR EARTHING.

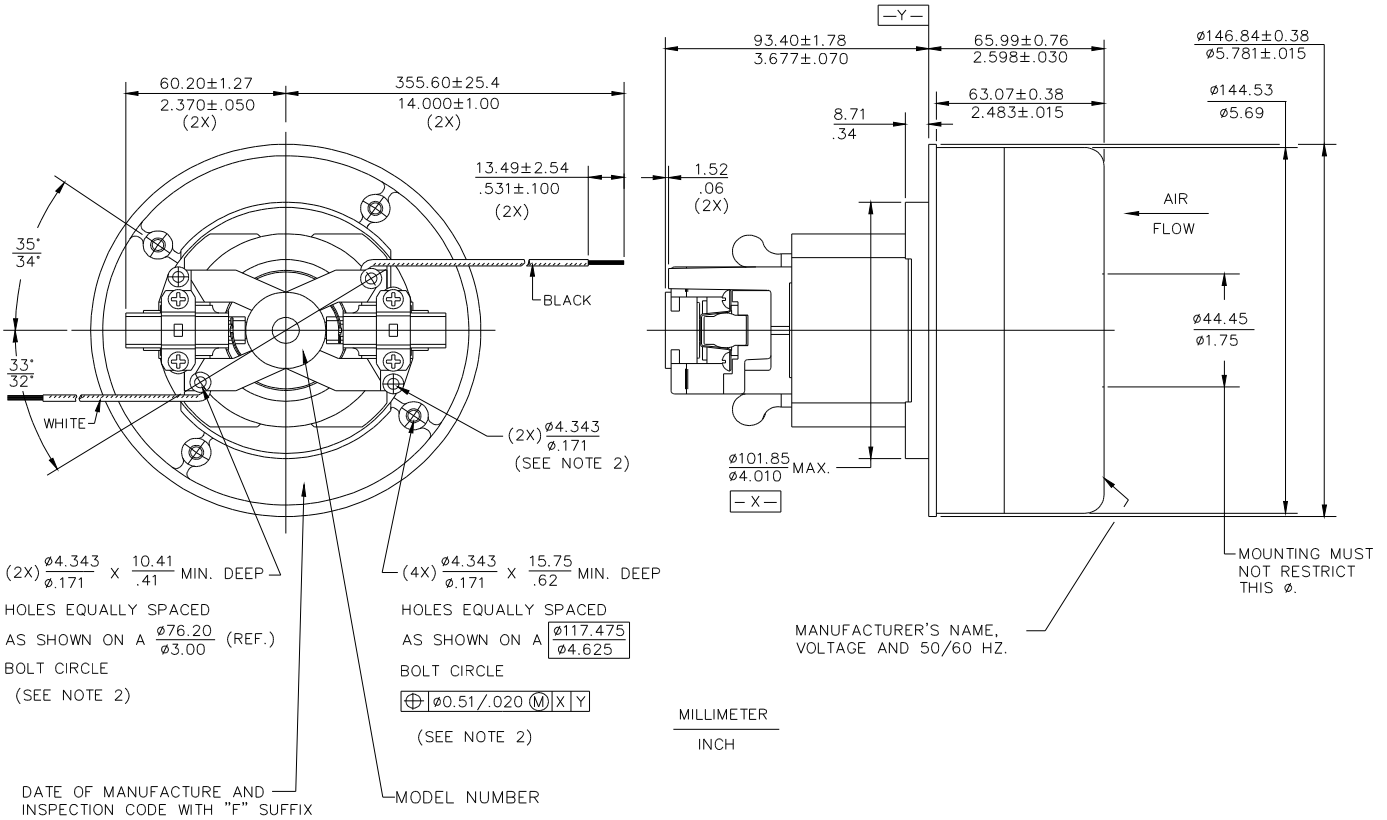

IMPORTANT NOTE: Pictorial and dimensional data are subject to change without notice. Contact factory for current revision levels.

WARNING - AMETEK Lamb Electric thru-flow vacuum motors must never be used in applications in which wet or moist conditions are involved, where dry chemicals or other volatile materials are present, or where airflow may be restricted or blocked. Such motors are designed to permit the vacuumed air to pass over the electrical winding to cool it. Thus any foam, liquid (including water), dry chemical, or other foreign substance coming in contact with electrical conductors could cause combustion (depending on volatility) or electrical shock. Failure to observe these precautions could result in property damage and severe personal injury, including death in extreme cases. All applications incorporating Lamb Electric motors should be submitted to Underwriters Laboratories Inc. or other appropriate organizations or agencies for testing specifically related to the safety of your equipment.

AMETEK/Floorcare & Specialty Motors
www.ametekfsm.com